

# Surface Mount Oven Stabilized Oscillator DOC - Series

# CONNOR WINFIELD

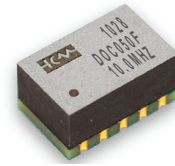

## Description:

Connor-Winfield's high stability DOC - series are exceptionally precise frequency standards, excellent for use in cellular base stations, test equipment, Synchronous Ethernet and VSAT applications.

These true surface mount OCXOs / OCVCXOs provide temperature stabilities in the range of  $\pm 20$  ppb to  $\pm 100$  ppb, over the commercial, extended commercial or the industrial temperature range.

The DOC - series is available with a CMOS output along with optional Electronic Frequency Tuning (OCVCXO). These oscillators provide outstanding phase noise characteristics that will meet the most stringent requirements.

## Features:

- OCXO / OCVCXO
- 3.3 Vdc Operation
- SMT Package
- Frequency Stabilities Available:
  - $\pm 20$  ppb,  $\pm 50$  ppb or  $\pm 100$  ppb
- Temperature Ranges Available:
  - 0 to 70°C, -20 to 75°C or -40 to 85°C
- Low Phase Noise
- LVC MOS Output
- Optional Electronic Frequency Tuning
- RoHS Compliant / Lead Free

2111 Comprehensive Drive  
Aurora, Illinois 60505  
Phone: 630-851-4722  
Fax: 630-851-5040  
[www.conwin.com](http://www.conwin.com)

## Package Outline

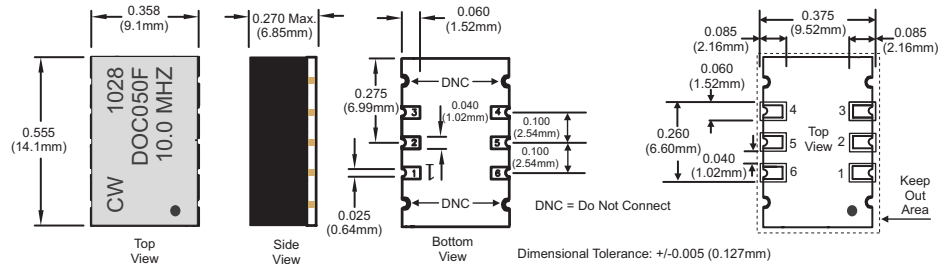

## Suggested Pad Layout

## Pad Connections

- 1: N/C or Vc option
- 2: N/C
- 3: Ground:
- 4: Output
- 5: N/C
- 6: Supply Voltage (Vcc)

## Ordering Information

<b>DOC</b> Oscillator Type 3.3 Vdc LVC MOS Output Surface Mount OCXO	<b>05</b> Frequency Stability 02 = $\pm 20$ ppb 05 = $\pm 50$ ppb 10 = $\pm 100$ ppb	<b>0</b> Temperature Range 0 = 0 to 70°C 1 = -20 to 75°C 2 = -40 to 85°C	<b>F</b> Voltage Control Option F = OCXO (Fixed Freq.) V = OCVCXO (Voltage Controlled)	<b>-010.0M</b> Output Frequency Frequency Format -xxx.xM Min.* -xxx.xxxxxM Max*
---	--	--	---	---

\*Amount of numbers after the decimal point.  
M = MHz

Example Part Numbers:

DOC050F-010.0M = 9x14mm package,  $\pm 50$  ppb, 0 to 70°C, 3.3 Vdc, CMOS Output, OCXO, Output Frequency 10.0 MHz

DOC022V-020.0M = 9x14mm package,  $\pm 20$  ppb, -40 to 85°C, 3.3 Vdc, CMOS Output, OCVCXO, 20.0 MHz

Specifications subject to change without notice. All dimensions in inches. © Copyright 2010 The Connor-Winfield Corporation



Bulletin **Cx207**  
Page **1 of 4**  
Revision **P09**  
Date **04 Apr 2011**



## Absolute Maximum Ratings

Parameter	Minimum	Nominal	Maximum	Units	Notes
Storage Temperature	-55	-	125	°C	
Supply Voltage - 3.3 Vdc (Vcc)	-0.5	-	4.5	Vdc	
Supply Voltage - 5.0 Vdc (Vcc)	-0.5	-	7.0	Vdc	
Control Voltage (Vc)	-0.5	-	Vcc+0.5	Vdc	

## Operating Specifications

Parameter	Minimum	Nominal	Maximum	Units	Notes
Center Frequency: (Fo)	10, 12.8, 19.44, 20 or 25			MHz	
Frequency Stability vs. Change in Temperature: (See Ordering Information)					
Stability Code 02	-20.0	-	20.0	ppb	1
Stability Code 05	-50.0	-	50.0	ppb	1
Stability Code 10	-100.0	-	100.0	ppb	1
Operating Temperature Range: (See Ordering Information)					
Temperature Code 0	0	-	70	°C	
Temperature Code 1	-20	-	75	°C	
Temperature Code 2	-40	-	85	°C	
Frequency Calibration:	-1.0	-	1.0	ppm	2
Frequency Stability vs Load	-20	-	20	ppb	±5%
Frequency Stability vs Voltage	-20	-	20	ppb	±5%
Aging: Daily:	-10	-	10	ppb/day	3
Aging: First Year:	-300	-	300	ppb	3
Supply Voltage: (Vcc)	3.13	3.30	3.47	Vdc	±5%
Power Consumption: Vcc = Nominal Voltage					
Turn On	-	-	3.0	W	
Steady State @ 25°C	-	-	1.3	W	
Phase Jitter: (BW: 10 Hz to Fo/2)	-	-	1.0	ps RMS	
Short Term Stability	-	-	1.0E-9/s		
Start-Up Time:	-	-	1	ms	
Warm Up Time (Within Specification @ 25°C)	-	-	60	s	
Warm Up Time (Within Specification @ -40°C)	-	-	90	s	

## CMOS Output Characteristics

Parameter	Minimum	Nominal	Maximum	Units	Notes
Load	-	15	-	pF	6
Output Voltage:					
3.3 Vdc Models	2.70	-	-	V	
High (Voh)					
Low (Vol)	-	-	0.30		
Duty Cycle at 50% of Vcc	45	50	55	%	
Rise / Fall Time: 10% to 90%	-	-	8	ns	

### Notes:

- 1 Frequency stability vs. change in temperature.  $[\pm(F_{max} - F_{min})/2.F_o]$ .
- 2 Initial calibration @ 25°C. For OCVCXO control voltage must be fixed.
- 3 After 30 days of operation
- 4 Positive slope. (Frequency increases as Vc voltage increases.)
- 5 Referenced to Fo.
- 6 Attention: To achieve optimal frequency stability, and in some cases to meet the specification stated on this data sheet, it is required that the circuit connected to this OCXO output must have the equivalent input capacitance that is specified by the nominal load capacitance. Deviations from the nominal load capacitance will have a graduated effect on the stability of approximately 20 ppb per pF load difference.

Bulletin	<b>Cx207</b>
Page	<b>2 of 4</b>
Revision	<b>P09</b>
Date	<b>04 Apr 2011</b>

### Phase Noise Characteristics

#### Typical Phase Noise for DOC050F - 010.0M

Parameter	Minimum	Nominal	Maximum	Units	Notes
@ 1 Hz offset	-	-67	-	dBC/Hz	
@ 10 Hz offset	-	-100	-	dBC/Hz	
@ 100 Hz offset	-	-130	-	dBC/Hz	
@ 1 KHz offset	-	-148	-	dBC/Hz	
@ 10 KHz offset	-	-154	-	dBC/Hz	
@ 100 KHz offset	-	-155	-	dBC/Hz	

### OCVCXO Input Characteristics (Optional)

Parameter	Minimum	Nominal	Maximum	Units	Notes
Control Voltage Range:	0.30	1.65	3.00	V	4
Frequency Pullability:	±10.0	-	-	ppm	5
Input Impedance	100K	-	-	Ohms	
Linearity	±5	-	-	%	

### Package Characteristics

DOC-Series Package      Package consisting of a FR4 substrate and a Ryton-R4 cover.

### Environmental Characteristics

Shock	500 G's 1ms, Halfsine, 3 shocks per direction, per MIL-STD 202G, Method 213B Test Condition D.
Sinusoidal Vibration	0.06" D.A. or 10G's Peak, 10 to 500 Hz, per MIL-STD-202G, Method 204D, Test Condition A.
Random Vibration	5.35 G's rms. 20 to 2000 Hz per MIL-STD-202G, Method 214, Test Condition 1A, 15 minutes each axis.
Moisture	10 cycles, 95% RH, Per MIL-STD-202G, Method 112.
Marking Permanency	Per MIL-STD-202G, Method 215J.
Solder Process	RoHS compliant, lead free. See solder profile on page 4.

### Recommended Cleaning Process

DOC-Series Package      Wash only in a inline high pressure wash station that has an air knife and drying capabilities.  
(Drying temperature range from 85° to 100°C)

Bulletin	<b>Cx207</b>
Page	<b>3 of 4</b>
Revision	<b>P09</b>
Date	<b>04 Apr 2011</b>

## CMOS Output Waveform

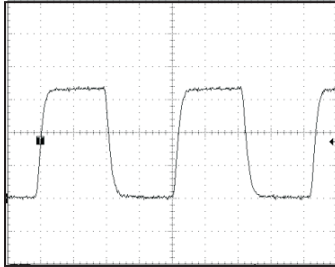

## CMOS Test Circuit

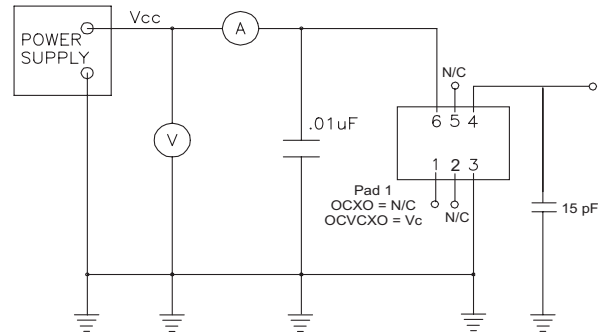

## Phase Noise Plot

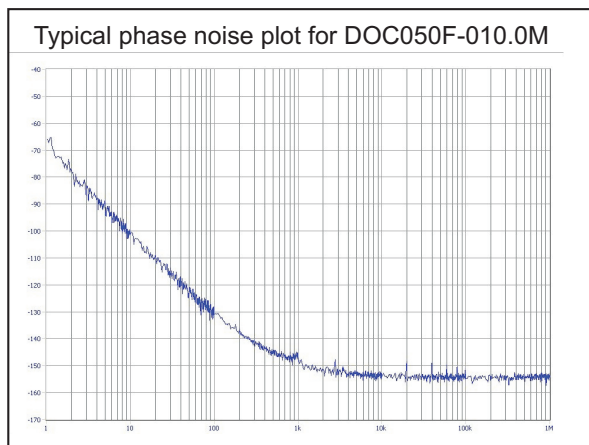

## RoHS Solder Profile

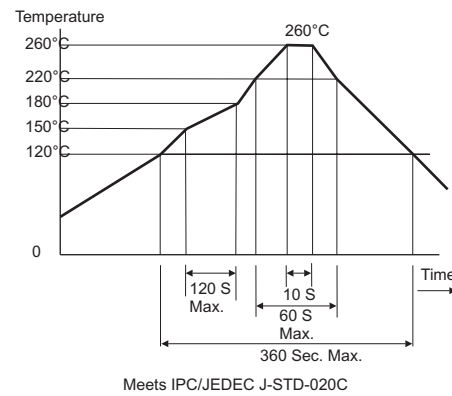

## Tape and Reel Information

MEETS EIA-481A & EIAJ-1009B  
500 PCS/REEL MAXIMUM

→ DIRECTION OF FEED (CUSTOMER)

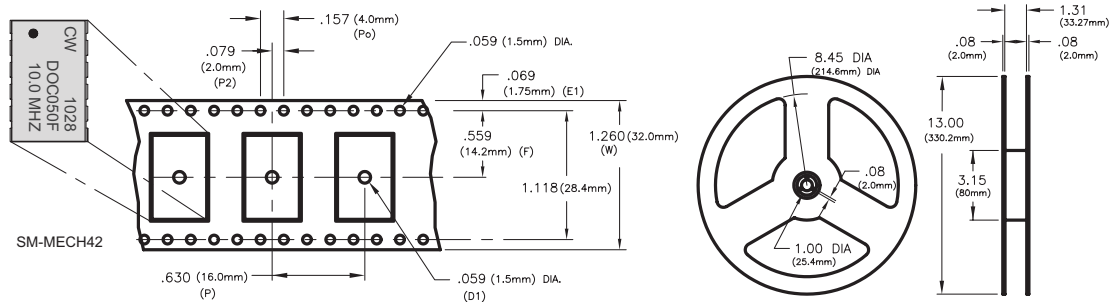

Bulletin	<b>Cx207</b>
Page	<b>1 of 4</b>
Revision	<b>P09</b>
Date	<b>04 Apr 2011</b>