

# Customer Information Sheet

SHEET 2 OF 2 | IF IN DOUBT - ASK | © | NOT TO SCALE | THIRD ANGLE PROJECTION | ALL DIMENSIONS IN mm

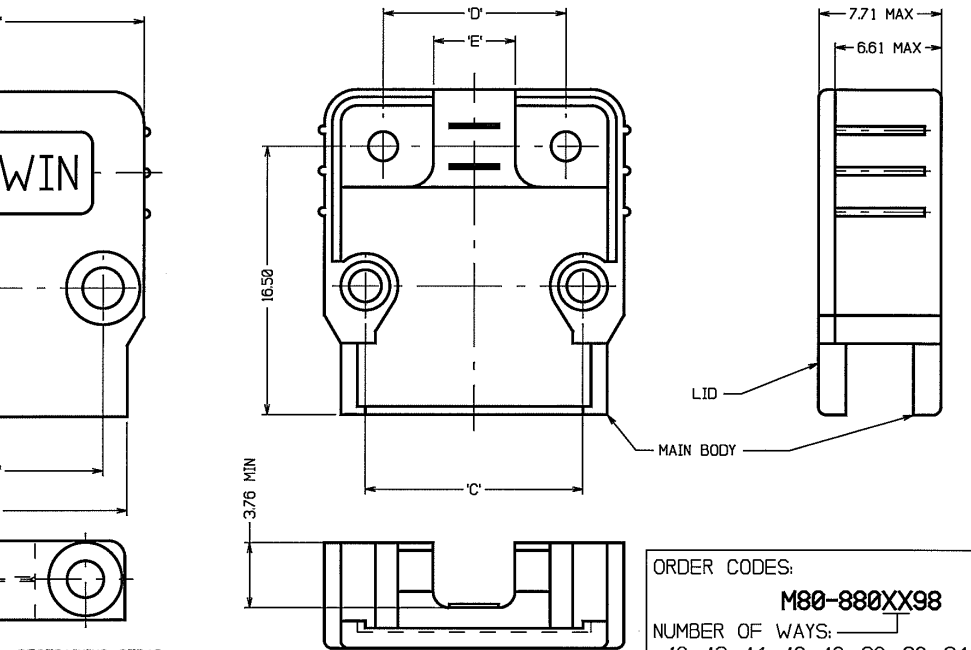

ORDER CODES:  
**M80-880XX98**  
 NUMBER OF WAYS: \_\_\_\_\_  
 10, 12, 14, 16, 18, 20, 26, 34

RESTRAINING STRAP DIMENSIONS

'B'	'C'	'D'	'E'
14.30	11.30	9.15	5.00
16.30	13.30	11.15	5.00
18.30	15.30	13.15	6.00
20.30	17.30	15.15	6.00
22.30	19.30	17.15	7.00
24.30	21.30	19.15	8.00
30.30	27.30	25.15	10.00
38.30	35.30	33.15	14.00

- NOTES:
- ASSEMBLY KIT ALSO INCLUDES 2 OFF 2 x 4.5 LONG FOR STRAP & 2 OFF 2 x 6.0 LONG FOR LID SELF TAPPING SCREWS.
  - MATERIAL FOR LID, BODY & STRAP: 30% GLASS FILLED POLYESTER, UL94V-0, BLACK.
  - FOR INSTRUCTION SPECIFICATIONS, SEE INSTRUCTION SHEET IS-08.

RA	5	16.03.09	10311
NAME	ISS.	DATE	C/NOTE
APPROVED: <i>[Signature]</i>			
CHECKED: <i>[Signature]</i>			
DRAWN: P. COLLINS			
CUSTOMER REF.:			
ASSEMBLY DRG:			

**HARWIN**  
 e (UK) HARWIN Asia  
 4545 TEL: +65 6 779 4909  
 4590 FAX: +65 6 779 3868  
 o.uk mis@harwin.com.sg

THIS DRAWING AND ANY INFORMATION OR DESCRIPTIVE MATTER SET OUT HEREON ARE CONFIDENTIAL AND COPYRIGHT PROPERTY OF THE HARWIN GROUP AND MUST NOT BE DISCLOSED, LOANED, COPIED OR USED FOR MANUFACTURING, TENDERING OR FOR ANY OTHER PURPOSE WITHOUT THEIR WRITTEN PERMISSION.

TOLERANCES  
 X. = ±1mm  
 X.X = ±0.25mm  
 X.XX = ±0.10mm  
 X.XXX = ±0.01mm  
 ANGLES = ±5°  
 UNLESS STATED

MATERIAL: SEE NOTES  
 FINISH: CLEAN + FLASH FREE  
 S/AREA: mm<sup>2</sup>

TITLE: DATAMATE CABLE HOOD ASSEMBLY/KIT  
 DRAWING NUMBER: **M80-880XX98**

SHT 2 OF 2