

NOTES: UNLESS OTHERWISE SPECIFIED

1. CONSTRUCTION:  
SLIDE: MOLDED NYLON TYPE 6,6. AVAILABLE IN TEN COLORS.

CONTACT BLADE: NICKEL SILVER ALLOY 770.  
SPRING: STAINLESS STEEL TYPE 302.

2. PERFORMANCE:

MAXIMUM CURRENT: 5 AMPS  
MAXIMUM VOLTAGE: 0 V  
MAXIMUM TEMPERATURE: 200°F (93°C)

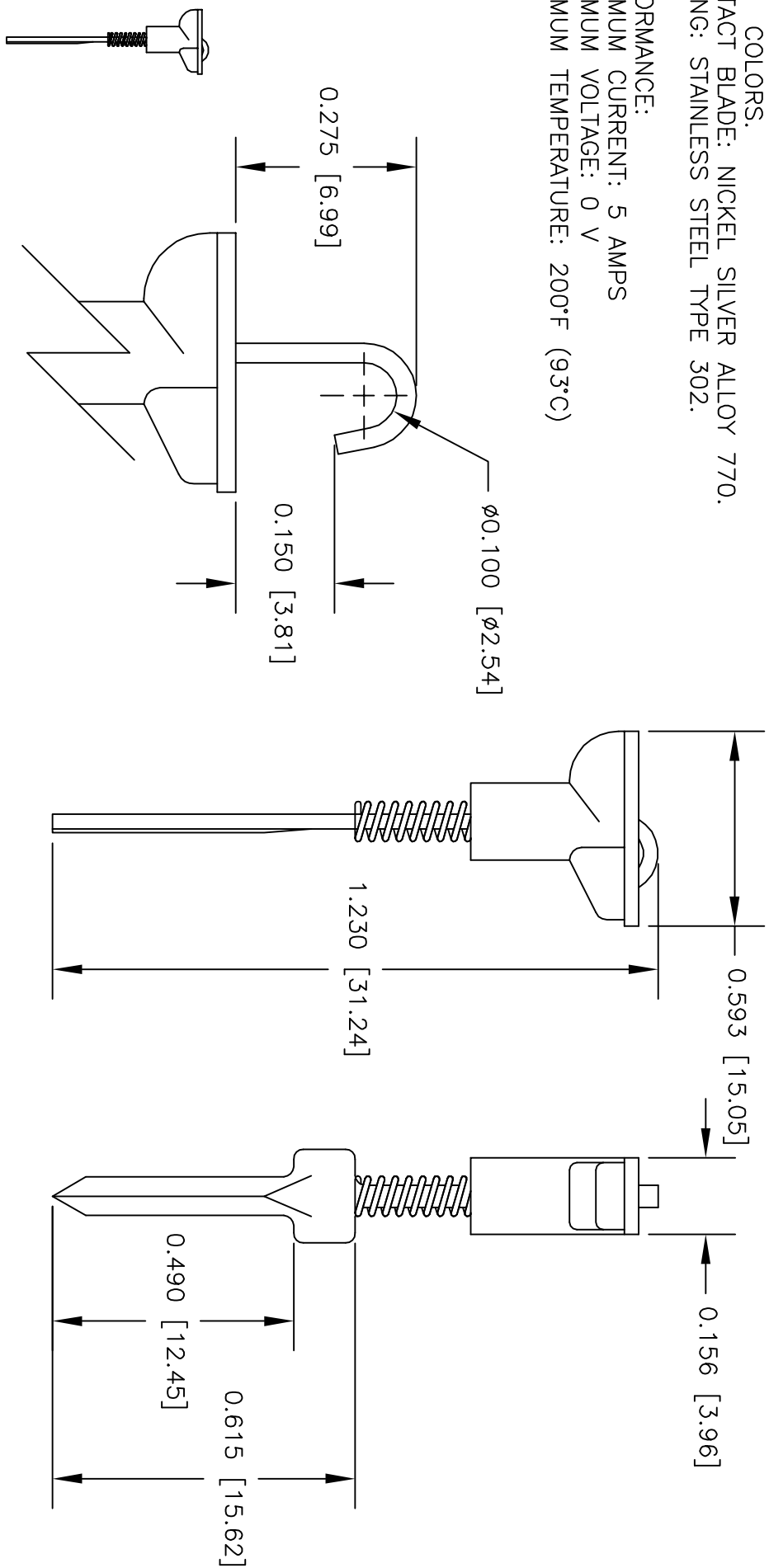

ACTUAL SIZE HOOK DETAIL  
SCALE: 4:1

LTR	DESCRIPTION	REVISIONS	DATE	APPROVED

CONTRACT NO.

UNLESS OTHERWISE SPECIFIED DIMENSIONS ARE IN INCHES TOLERANCES ARE: FRACTIONS DECIMALS ANGLES ± .XX ± .XXX ±

MATERIAL SEE NOTE.

FINISH SEE NOTE.

APPLICATION USED ON DO NOT SCALE DRAWING

**E-Z-HOOK** DIVISION OF TEKTEST INC. ARCADIA, CA 91006 U.S.A.  
DESCRIPTION: STD TEST TERMINAL

SIZE CODE IDENT NO. DRAWING NO. REV

A 08505 81-1

SCALE 1:1 SHEET 1 OF 1

THE INFORMATION CONTAINED IN THIS DOCUMENT IS PROPRIETARY TO E-Z-HOOK. THE INFORMATION IS NOT TO BE REPRODUCED WITHOUT PRIOR WRITTEN PERMISSION OF E-Z-HOOK, DIV. OF TEKTEST INC. MAXIMUM TESTED RATINGS IN A HANDS-FREE CONTROLLED ENVIRONMENT. MAXIMUM RATINGS ARE NOT TO BE USED CONCURRENTLY.