

NOTES: UNLESS OTHERWISE SPECIFIED

LTR

DESCRIPTION

REVISIONS

DATE

APPROVED

1. CONSTRUCTION:

HOUSING & PLUNGER: MOLDED NYLON TYPE 6,6. AVAILABLE IN RED & YEL.
 CONTACT BLADE: BERYLLIUM COPPER PER QQ-C-533. GOLD PLATER PER MIL-G-45204 TYPE 1, 0.00001 [0.000254] THICK MINIMUM.
 SPRING: STAINLESS STEEL TYPE 302.

2. PERFORMANCE:

MAXIMUM CURRENT: 4.4 AMPS WITH 76° TEMPERATURE RISE.
 MAXIMUM VOLTAGE: 2.4 KV
 MAXIMUM TEMPERATURE: 200°F (93°C)

3. FEATURES:

HOOK FITS COMPONENTS UP TO $\phi 0.040$ [$\phi 1.01$].
 FIELD SERVICEABLE.

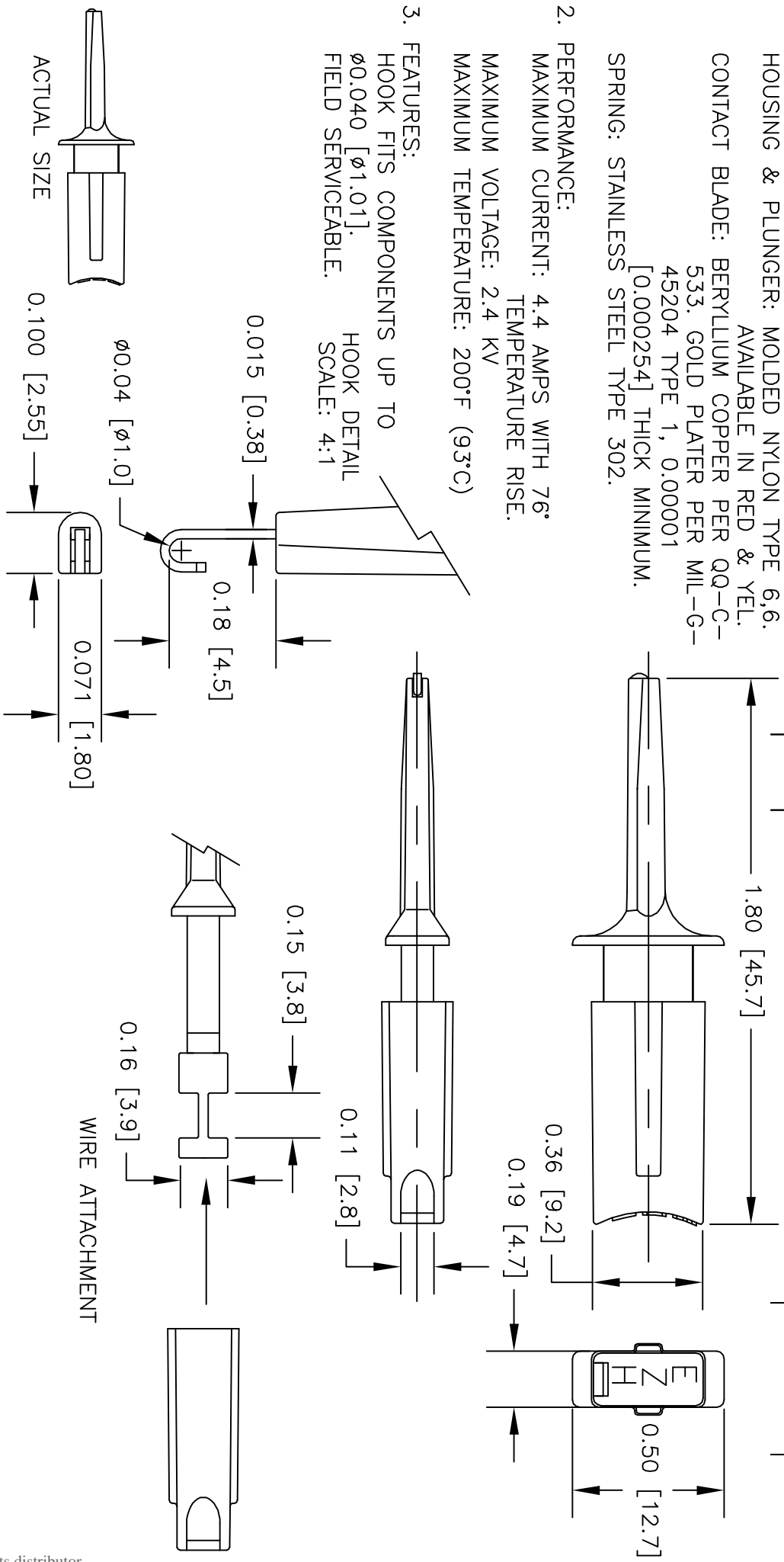

	UNLESS OTHERWISE SPECIFIED DIMENSIONS ARE IN INCHES TOLERANCES ARE: FRACTIONS DECIMALS ANGLES
	± .XX ±
	± .XXX ±
	MATERIAL SEE NOTE.
	FINISH SEE NOTE.
USED ON	
APPLICATION	DO NOT SCALE DRAWING

CONTRACT NO.	
APPROVALS	DATE
R.L.	6/09
APPROVED BY	

EZ-HOOK DIVISION OF TEKTEST INC. ARCADIA, CA 91006 U.S.A.	
DESCRIPTION E-Z-MICRO HOOK TEST CONNECTOR	
SIZE	CODE IDENT NO. DRAWING NO.
A	08505 XMRCOLOR
SCALE	2:1
SHEET 1 OF 1	REV

THE INFORMATION CONTAINED IN THIS DOCUMENT IS PROPRIETARY TO E-Z-HOOK. THE INFORMATION IS NOT TO BE REPRODUCED WITHOUT PRIOR WRITTEN PERMISSION OF E-Z-HOOK, DIV. OF TEKTEST INC. MAXIMUM TESTED RATINGS IN A HANDS-FREE CONTROLLED ENVIRONMENT. MAXIMUM RATINGS ARE NOT TO BE USED CONCURRENTLY.