

NOTES: UNLESS OTHERWISE SPECIFIED

1. CONSTRUCTION:
HOUSING & PLUNGER: MOLDED NYLON TYPE 6.6.
AVAILABLE IN TEN COLORS.
CONTACT BLADE: NICKEL SILVER ALLOY CA 770.
SPRING: STAINLESS STEEL TYPE 302.

2. PERFORMANCE:
MAXIMUM CURRENT: 13.1 AMPS WITH A 76°
TEMPERATURE RISE.
MAXIMUM VOLTAGE: 2.4 KV
MAXIMUM TEMPERATURE: 200°F (93°C)

3. FEATURES:
HOOK FITS COMPONENTS UP TO
Ø0.140" [3.56].
FIELD SERVICEABLE.

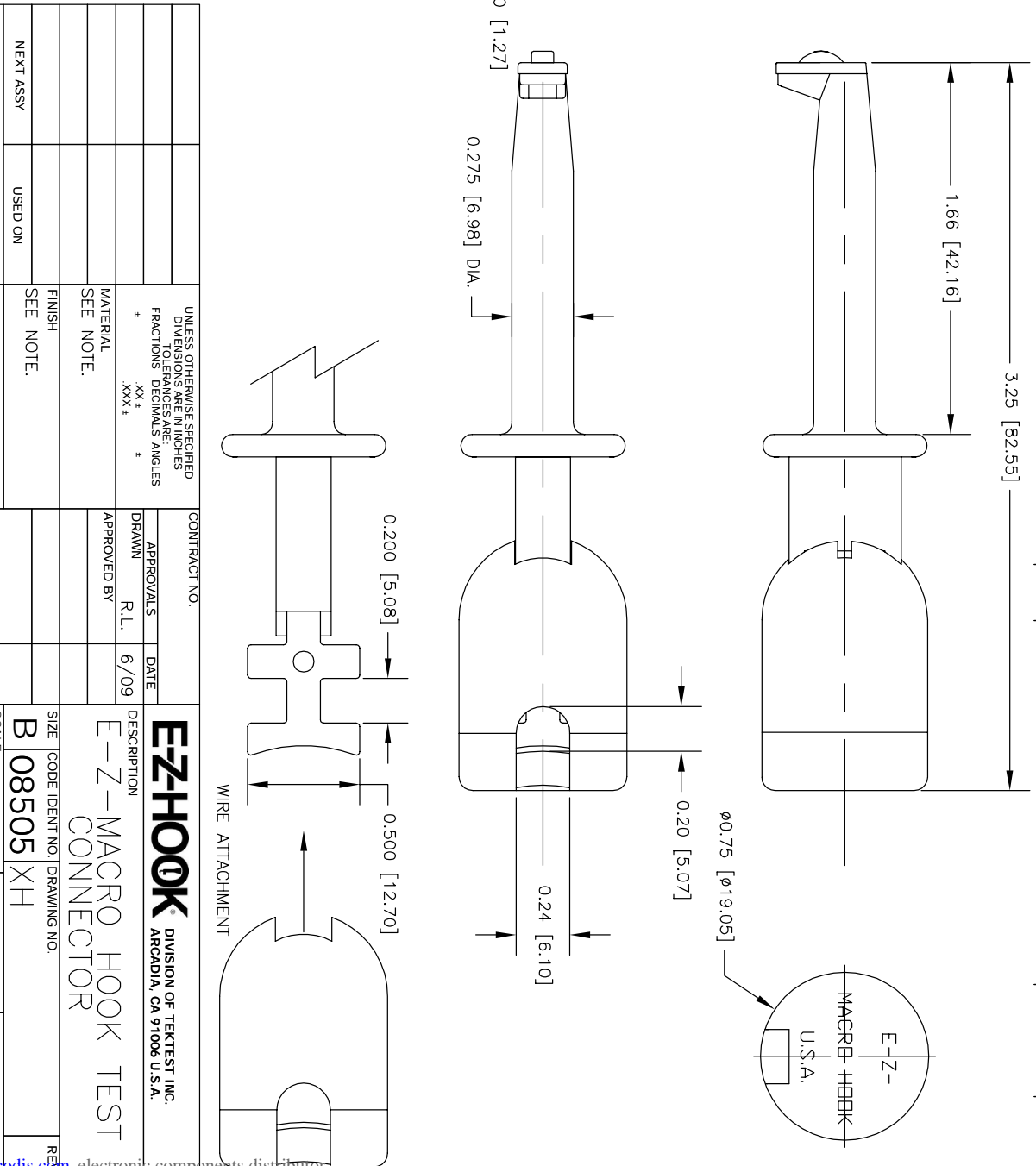
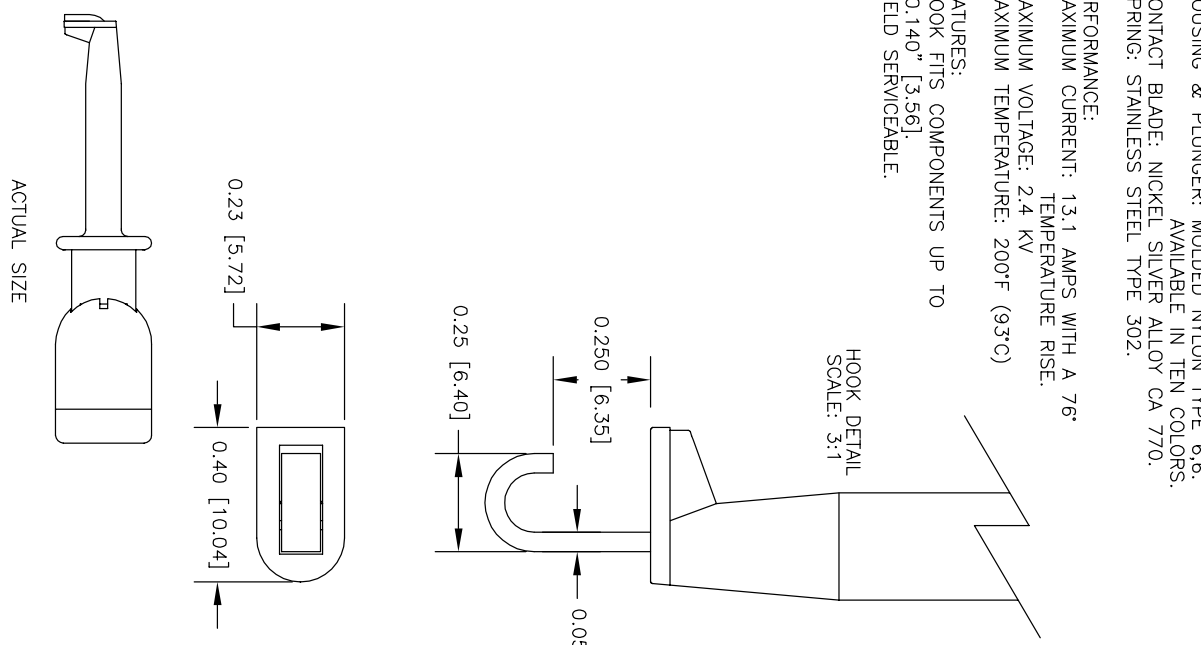

REVISIONS		DATE	APPROVED
LTR	DESCRIPTION		

UNLESS OTHERWISE SPECIFIED DIMENSIONS ARE IN INCHES FRACTIONS DECIMALS ANGLES .XXX ±		CONTRACT NO.	
MATERIAL SEE NOTE.		APPROVALS	DATE
FINISH SEE NOTE.		R.L.	6/09
NEXT ASSY USED ON		APPROVED BY	
APPLICATION DO NOT SCALE DRAWING		DESCRIPTION	
		E-Z-HOOK DIVISION OF TEKTEST INC. ARCADIA, CA 91006 U.S.A.	
		E-Z-MACRO HOOK TEST CONNECTOR	
SCALE	SIZE	CODE	IDENT NO.
2:1	B	08505	XH
SHEET 1 OF 1		DRAWING NO.	

THE INFORMATION CONTAINED IN THIS DOCUMENT IS PROPRIETARY TO E-Z-HOOK. THE INFORMATION IS NOT TO BE REPRODUCED WITHOUT PERMISSION OF E-Z-HOOK, DIV. OF TEKTEST INC. MAXIMUM TESTED RATING IN HANDS-FREE CONTROLLED ENVIRONMENT. MAXIMUM TESTED RATING IN HANDS-ON ENVIRONMENT.