

SHEET 1 OF 1

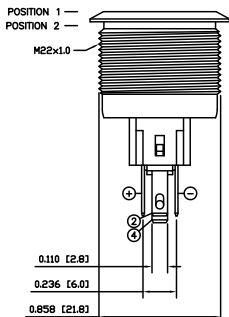

SUGGESTED PANEL CUTOUT

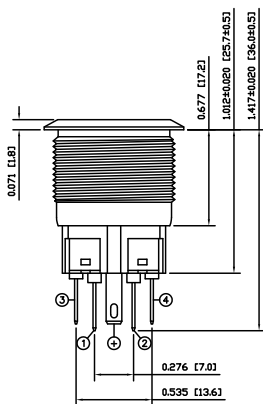
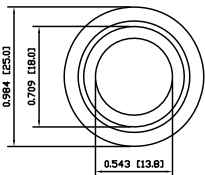
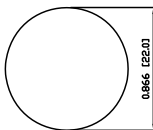

MAXIMUM PANEL THICKNESS: 0.315 [8.0mm]

SCHEMATIC

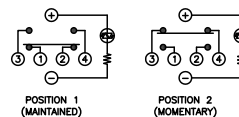

SPECIFICATIONS

FUNCTION:
1PNO OFF-(ON) + 1PNC ON-(OFF)

RATING:
2A 48VDC

ILLUMINATION VOLTAGE:
12V 20mA

CONTACT RESISTANCE:
Initial: 50mΩ Max. at 1A 12VDC

INSULATION RESISTANCE:
1,000MΩ Min. at 500VDC

DIELECTRIC STRENGTH:
2,000VAC Min. for 1 Minute

ELECTRICAL LIFE:
50,000 Cycles

MECHANICAL LIFE:
1,000,000 Cycles

TEMPERATURE:
Operating: -20°C to 70°C

INGRESS PROTECTION:
IP65

APPROVALS:
RoHS
COMPLIANT

MATERIALS

BUSHING:
Stainless Steel (304)

BASE:
Polyamide 6/6 (PA66)

ACTUATOR:
Stainless Steel (304)
Polycarbonate (PC)

HARDWARE:
Nickel Plated Brass (H59)

SEALING:
Silicone Rubber

INNER ASSEMBLY:
Polycarbonate (PC)
Polysymethylene (POM)
Brass (H62)
Stainless Steel (304)

SPRING:
Stainless Steel (304)

CONTACTS:
Silver/Cadmium Oxide (AgCdO)

TERMINALS:
Brass (H62)

O-RING:
Silicone Rubber

COLORS AND FINISH

BEZEL:
Stainless Steel
Machine Finish

ACTUATOR:
Stainless Steel
Machine Finish

ILLUMINATION:
Yellow (Forward)
Yellow (Reverse)

MARKING:
None

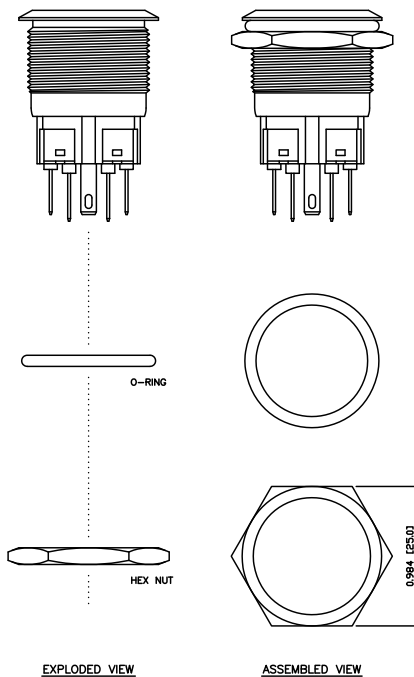

EXPLODED VIEW

ASSEMBLED VIEW

BODY	A	09/07/22	CAB
COLORS	A	09/07/22	CAB
MATERIALS	B	09/12/02	CAB
SPECIFICATIONS	B	09/12/29	CAB
REFERENCE	REV.	DATE	BY

THE INFORMATION CONTAINED IN THIS DOCUMENT IS PROPRIETARY TO E-SWITCH AND IS NOT TO BE COPIED OR TRANSFERRED

INITIAL RELEASE	19735	11/03/07	CAB
DESCRIPTION	PCR	DATE	DRAWN BY

DIMENSIONS	INCHES [MILLIMETERS]
GENERAL TOLERANCES	±0.008 [±0.2] / ±1°
SCALE	DRAWING NOT TO SCALE
PROJECTION	1st Angle

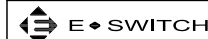

TITLE	PV7F2Y0SS-354		
ITEM NUMBER	52-PV7F2Y0SS354	DATE	MARCH 7, 2011
REVISION	A		