

- ANTI-VANDAL SWITCHES
- DETECTOR SWITCHES
- DIP SWITCHES
- KEYLOCK SWITCHES
- NAVIGATION SWITCHES
- PUSHBUTTON SWITCHES
- ROCKER SWITCHES
- ROTARY SWITCHES
- SLIDE SWITCHES
- SNAP ACTION SWITCHES
- TACTILE SWITCHES
- TOGGLE SWITCHES
- CAP OPTIONS



APPLICATIONS / MARKETS



Portable Equipment



Gaming and Computer



Security Devices

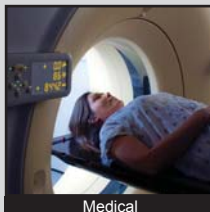

Medical

RoHS

SPECIFICATIONS

Electrical Rating: 20mA, 24V (AC or DC)
Life Expectancy: 1,000,000 Cycles
Contact Resistance: 5Ω Max.
Insulation Resistance: 100MΩ Min. at 500VDC
Dielectric Strength: 500VAC for 1 Minute
Operating Temperature: -25°C to 70°C

Function: SPST

FEATURES & BENEFITS

- 1,000,000 cycle life expectancy
- The switch is triggered when tilted 45 degrees of the horizontal
- Environmentally friendly, contains no mercury

PART NUMBER CONFIGURATOR

Series Model Contact Material

TM **1000** **Q - Silver**

Specifications subject to change without notice



E-SWITCH®



www.e-switch.com

800.867.2717

1

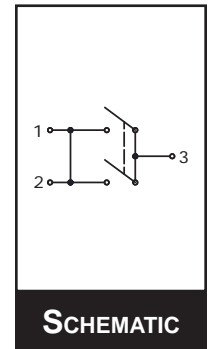
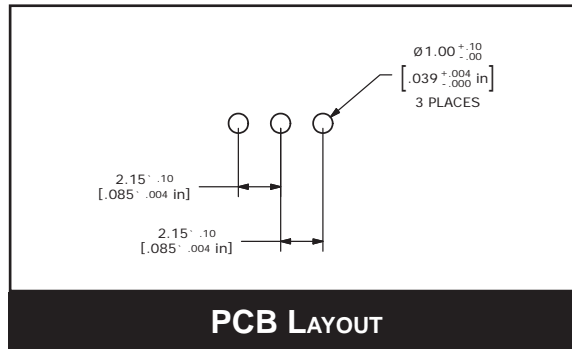
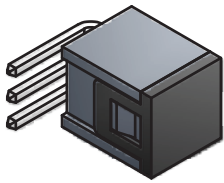

ON - OFF ANGLES

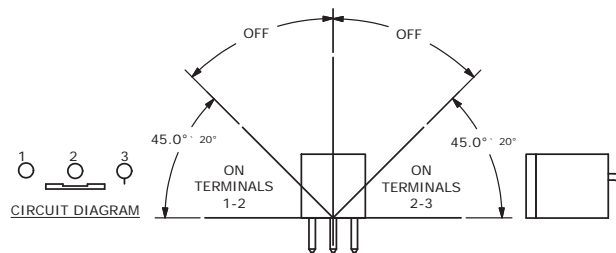

BODY DIMENSIONS

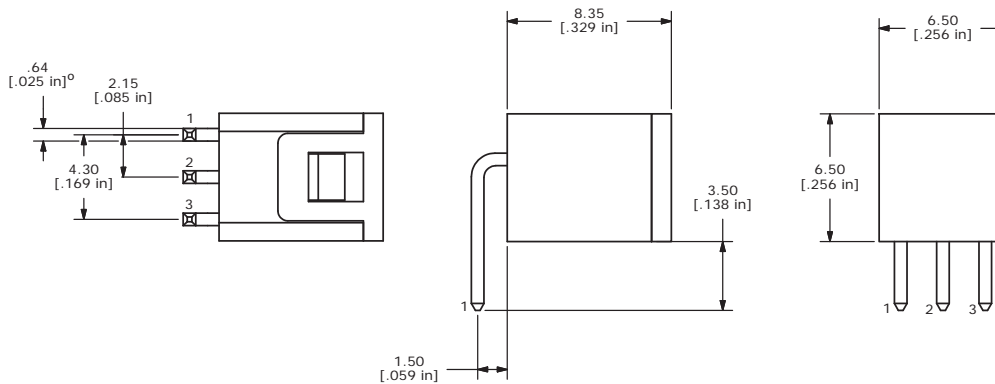

- ANTI-VANDAL SWITCHES
- DETECTOR SWITCHES
- DIP SWITCHES
- KEYLOCK SWITCHES
- NAVIGATION SWITCHES
- PUSHBUTTON SWITCHES
- ROCKER SWITCHES
- ROTARY SWITCHES
- SLIDE SWITCHES
- SNAP ACTION SWITCHES
- TACTILE SWITCHES
- TOGGLE SWITCHES
- CAP OPTIONS

