

PRECISION TEMPERATURE-TO-VOLTAGE CONVERTERS WITH SHUTDOWN MODE

FEATURES

- Linearized Temperature-to-Voltage Converters
- Direct Centigrade Output Voltage Scaling (TC1023)
- Shutdown/Calibrate Mode
- Multi-Zone Temperature Sensing Capability
- Wide Temperature Measurement Range (TC1024) - 20°C to +125°C
- Excellent Temperature Converter Linearity .. 0.8°C Over Temperature
- High Temperature Converter Accuracy ± 2°C at 25°C Guaranteed
- Small Packages 8-Pin SOIC and 8-Pin MSOP

APPLICATIONS

- Power Supply Thermal Shut-Down
- Temperature-Controlled Fans
- Temperature Measurement/Instrumentation
- Temperature Regulators
- Consumer Electronics
- Lithium Battery Temperature Monitor

TYPICAL APPLICATION

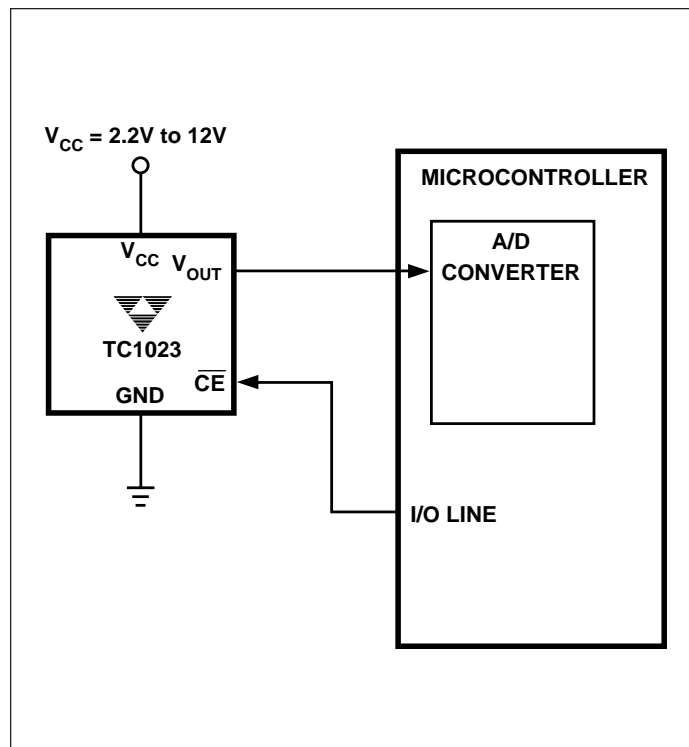

GENERAL DESCRIPTION

The TC1023/1024 temperature sensors furnish a linearized output voltage directly proportional to measured temperature. The TC1023 has a temperature measurement range of - 20°C to +100°C. Its output voltage is directly calibrated in degrees Centigrade (i.e., $V_{OUT} = 10mV/°C \times \text{Temperature } °C$). An external pull-down resistor to a negative voltage source is required for temperature measurement below 0°C.

The TC1024 has a temperature measurement range of - 20°C to +125°C, and operates with a single supply. It has the same output voltage slope with temperature as the TC1023 (10mV/°C). The output voltage range is 100mV at - 20°C to 1,750mV at +125°C. Both devices have a chip enable input that reduces supply current to 1µA (typical) when pulled active high. In this state, the output defaults to a high resistance allowing an external reference voltage to be directly connected for A/D calibration.

Small size, low cost, flexibility and low power operation make the TC1023/1024 suitable for a wide range of general purpose temperature measurement applications.

ORDERING INFORMATION

Part No.	Package	Output Voltage At 25°C	Temp. Range
TC1023VOA	8-Pin SOIC	250mV	- 20°C to +100°C
TC1023VUA	8-Pin MSOP	250mV	- 20°C to +100°C
TC1024VOA	8-Pin SOIC	750mV	- 20°C to +125°C
TC1024VUA	8-Pin MSOP	750mV	- 20°C to +125°C

PIN CONFIGURATION

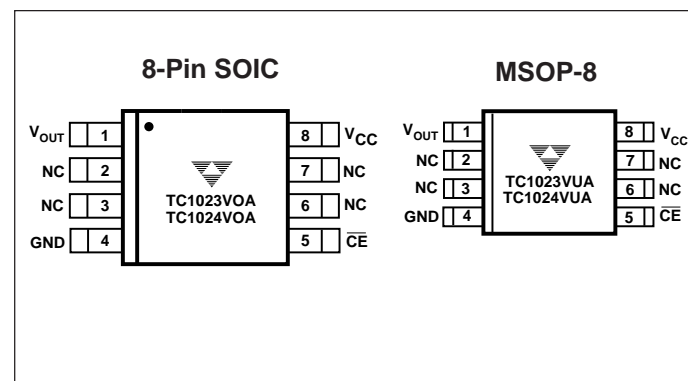

TC1023
TC1024

ABSOLUTE MAXIMUM RATINGS *

Supply Voltage	15V
Input Voltage, Any Terminal	- 1.0 to ($V_{CC} + 0.3V$)
Operating Temperature (TC1023)	- 20°C to +100°C
Operating Temperature (TC1024)	- 20°C to +125°C
Storage Temperature	- 55°C to +150°C
Lead Temperature (Soldering, 10 sec)	+300°C

* Static-sensitive device. Unused devices must be stored in conductive material. Protect devices from static discharge and static fields. Stresses above those listed under Absolute Maximum Ratings may cause permanent damage to the device. These are stress ratings only and functional operation of the device at these or any other conditions above those indicated in the operational sections of the specifications is not implied. Exposure to Absolute Maximum Rating Conditions for extended periods may affect device reliability.

ELECTRICAL CHARACTERISTICS : $T_A = -20^\circ\text{C}$ to $+125^\circ\text{C}$, $V_{CC} = 5V \pm 5\%$, $GND = 0V$, unless otherwise specified.

Symbol	Parameter	Test Conditions	Min	Typ	Max	Unit
V_{CC}	Supply Voltage (TC1023) (TC1024)		2.2 3.0	—	12 12	V
I_S	Supply Current	$\overline{CE} = V_{IL}$ (Note 1)	—	40	60	μA
I_{CE}	Shutdown Current	$\overline{CE} = V_{IH}$ (Note 2)	—	1	5	μA
V_{IH}	\overline{CE} Input Logic HIGH Level		2.0	—	—	V
V_{IL}	\overline{CE} Input Logic LOW Level		—	—	0.8	V
I_{CE}	\overline{CE} Input Leakage Current	$\overline{CE} = V_{IH}$ or V_{IL}	-1	—	+1	μA
t_{REC}	Recovery Time from Shutdown	$\overline{CE} = \text{step from } V_{IH} \text{ to } V_{IL}$ (Note 3)	—	400	—	μsec
V_{OUT}	V_{OUT} Output Voltage (TC1024)	$T_A = -20^\circ\text{C}$ and $+125^\circ\text{C}$	270	—	1780	mV
	V_{OUT} Output Voltage (TC1023)	$T_A = -20^\circ\text{C}$ and $+100^\circ\text{C}$ Circuit per Figure 1: $R1 = 240\text{k}\Omega$ $V_{SS} = -12V$ (Note 1)	- 230	—	1030	
I_{SRC}	V_{OUT} Output Source Current		—	—	1.0	mA
	Accuracy at Room Temperature	$T_A = +25^\circ\text{C}$ (Note 4)	- 2	—	+2	$^\circ\text{C}$
	Accuracy at Minimum Temperature	TC1023: $T_A = -20^\circ\text{C}$ TC1024: $T_A = -20^\circ\text{C}$ (Note 4)	- 4	—	+4	$^\circ\text{C}$
	Accuracy at Maximum Temperature	TC1023: $T_A = +100^\circ\text{C}$ TC1024: $T_A = +125^\circ\text{C}$ (Note 4)	- 3	—	+3	$^\circ\text{C}$
	Nonlinearity	Note 5	- 0.8	—	+0.8	$^\circ\text{C}$
	Line Regulation		—	80	—	$\mu\text{V/V}$
A_V	Average Slope of Output Voltage		—	10	—	$\text{mV}/^\circ\text{C}$
V_{OUTMAX}	Maximum Output Voltage	TC1023: $2.2V \leq V_{CC} \leq 12V$ TC1024: $3.0V \leq V_{CC} \leq 12V$ (Note 1)	—	—	$V_{CC} - 1.2$	V

- NOTES:**
- V_{OUT} outputs open circuited.
 - V_{OUT} is 0V through approximately 100k Ω to ground when $\overline{CE} = V_{IH}$.
 - Recovery time is the period required for V_{OUT} to rise from 0V (shutdown state) to the voltage corresponding to the measured temperature driving a 100pF capacitive load.
 - Accuracy = Difference between calculated output voltage (10mV/ $^\circ\text{C}$ x Device case temperature at specified temperature and power supply) and measured output voltage expressed in $^\circ\text{C}$.
 - Nonlinearity = deviation of output voltage versus temperature from the best-fit straight line over the device rated temperature range.

DETAILED DESCRIPTION

A plot of output voltage versus temperature for both the TC1023 and TC1024 appears in Figure 5. The TC1023 can be used with single power supply to measure temperatures from 0°C to 100°C. A pull-down resistor (R1 in Figure 1) must be added from the output pin to the negative power supply for measuring temperatures less than 0°C. The value of the resistor must be chosen to limit the maximum current pulled from the output to the negative supply to $-50\mu\text{A}$ (i.e., $R1 = V_{SS}/50\mu\text{A}$).

Output Stage

Both devices have Class A output stages capable of sourcing 1mA. These devices have a limited ability to drive heavy capacitive loads. Loads of 50pF (to ground) can be driven directly. For heavier loads, a 2kΩ (or greater) resistor should be placed in series with the output for decoupling. If the TC1023/1024 is used in a noisy electrical environment, a 0.1μF bypass capacitor from V_{CC} to GND is recommended.

Shutdown/Calibrate Mode

The TC1023/1024 enters shutdown when the $\overline{\text{CE}}$ input is taken to V_{IH}. This causes quiescent current to fall to 1μA (typ) and the output to drop immediately to 0V through approximately 100kΩ. For applications where the TC1023/1024 is connected to an external A/D converter, a reference voltage can be directly connected to V_{OUT} while in shutdown for A/D calibration, as shown in Figure 3. A CMOS gate provides bias voltage to the bandgap reference V_R, and at the same time disables the TC102x by taking $\overline{\text{CE}}$ to V_{IH}. Limiting resistor R1 should be chosen to limit current through the voltage reference to the desired current (I_{REF}). That is, $R1 = (V_{OH} - V_{REF})/I_{REF}$ (where V_{OH} is the CMOS gate output high voltage at output current equal to I_{REF}; and V_{REF} is the reference voltage of V_R).

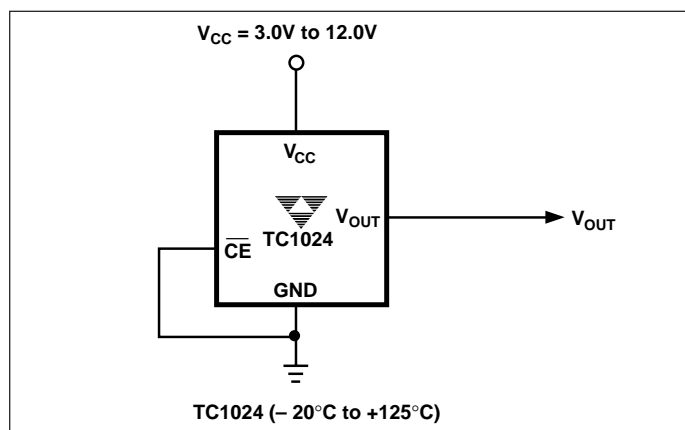

Figure 2. TC1024 Connections

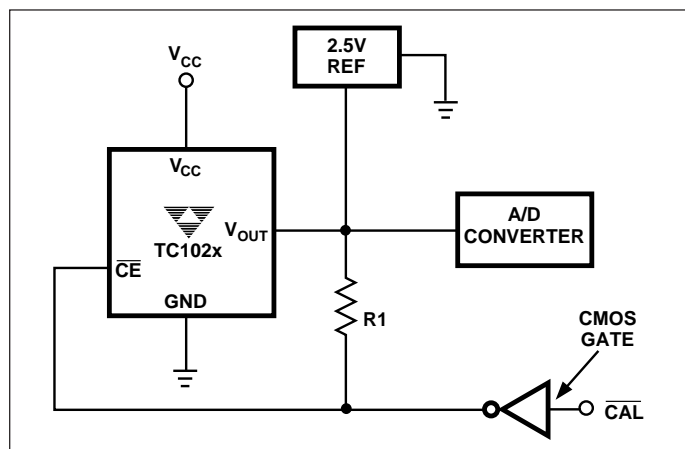

Figure 3. A/D Calibration

Multi-Zone Temperature Sensing

The $\overline{\text{CE}}$ input facilitates multi-zone temperature sensing as shown in the example of Figure 4. In this example, the processor addresses either of two sensors with a single I/O port pin. The TC102x V_{OUT} pins are connected together and routed to the processor's A/D converter, eliminating the need for separate A/D input channels for each sensor.

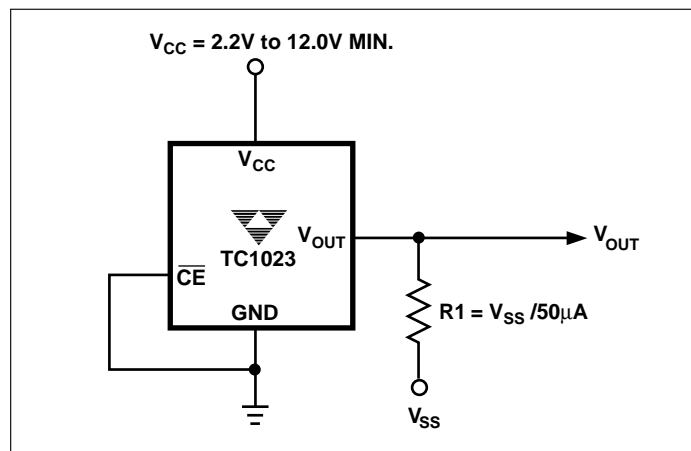

Figure 1. TC1023 Connections

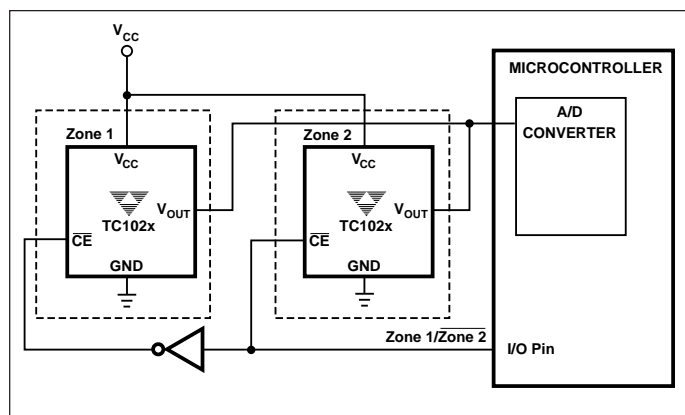

Figure 4. TC1023/1024 Addressing

TC1023
TC1024

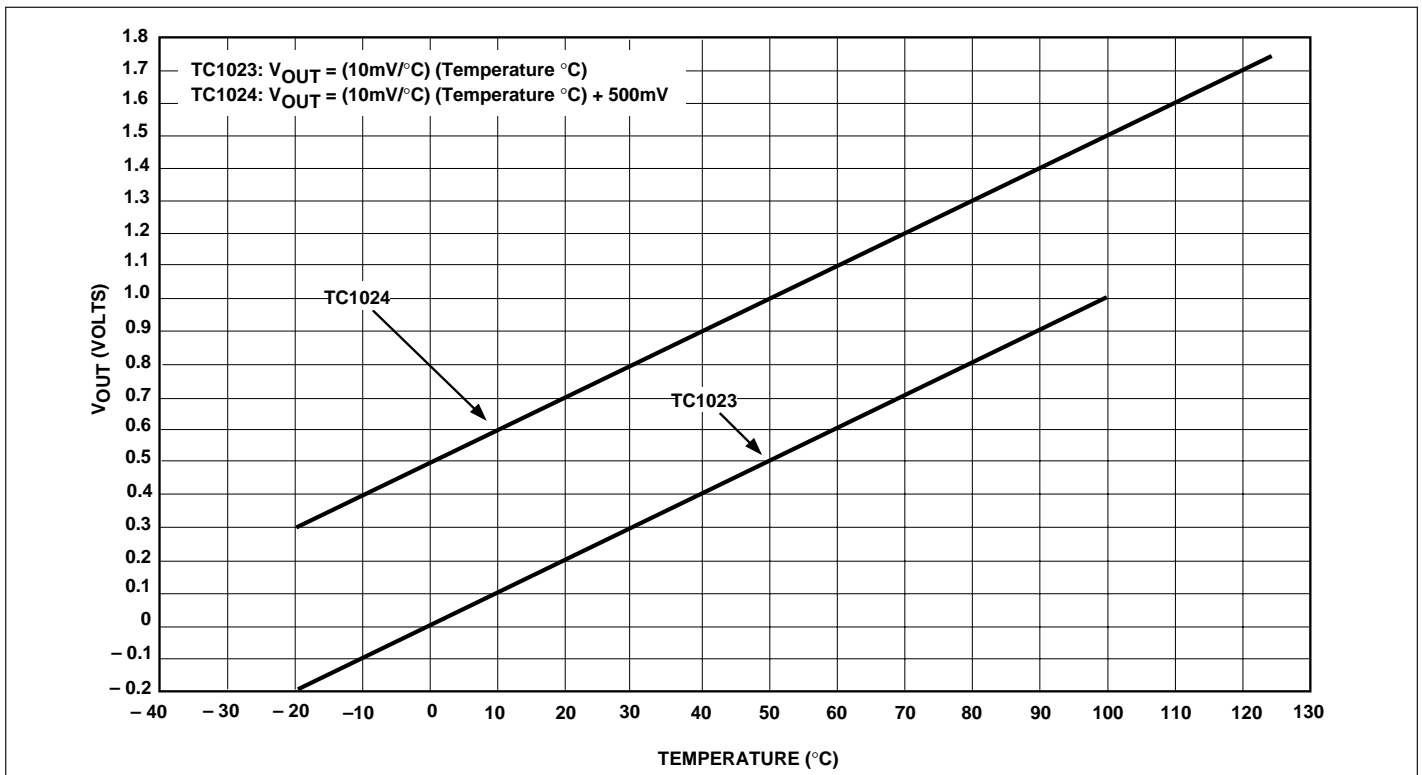
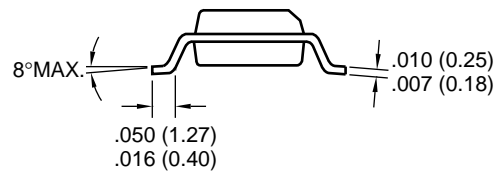
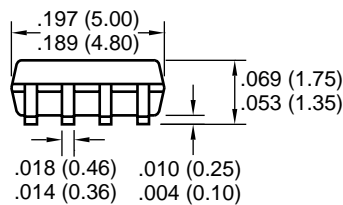
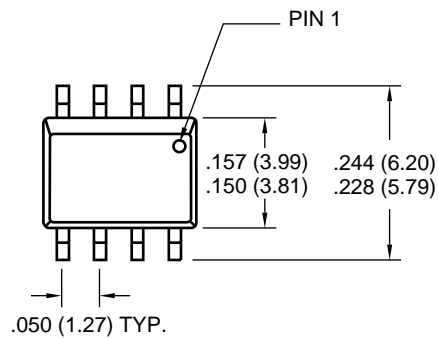

Figure 5. Output Voltage vs. Temperature

PACKAGE DIMENSIONS

8-Pin SOIC



8-Pin MSOP

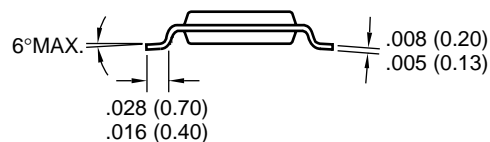
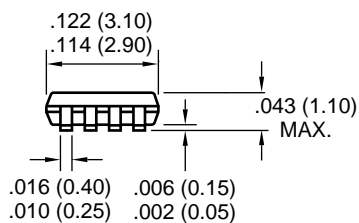
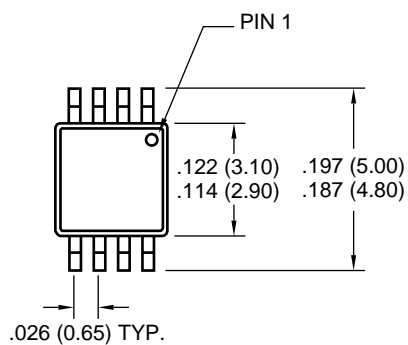

Dimensions: inches (mm)

TC1023
TC1024

Sales Offices

TelCom Semiconductor
1300 Terra Bella Avenue
P.O. Box 7267
Mountain View, CA 94039-7267
TEL: 415-968-9241
FAX: 415-967-1590
E-Mail: liter@c2smtp.telcom-semi.com

TelCom Semiconductor
Austin Product Center
9101 Burnet Rd. Suite 214
Austin, TX 78758
TEL: 512-873-7100
FAX: 512-873-8236

TelCom Semiconductor H.K. Ltd.
10 Sam Chuk Street, Ground Floor
San Po Kong, Kowloon
Hong Kong
TEL: 852-2324-0122
FAX: 852-2354-9957