





OPERATING CHARACTERISTICS 

GAUSS	
OPERATE MAX	495
RELEASE MIN	200
DIFF MIN	35

ABSOLUTE MAXIMUM RATINGS

SUPPLY VOLTAGE (Vs) 	-10 VDC +25.0 VDC
VOLTAGE EXTERNALLY APPLIED TO OUTPUT	+25 VOLTS DC MAX WITH SWITCH IN "OFF" CONDITION ONLY -0.5 VOLTS MAX WITH SWITCH IN "OFF" OR "ON" CONDITION
OUTPUT CURRENT	20 mA (SINK PER OUTPUT)
TEMPERATURE OPERATE AND STORAGE	-40°C TO 100°C
MAGNETIC FLUX	NO LIMIT, THE CIRCUIT CANNOT BE DAMAGED BY MAGNETIC OVERDRIVE

ELECTRICAL CHARACTERISTICS

	MIN	TYP	MAX	REMARKS
SUPPLY CURRENT (OPERATED)			10.0mA	ON CONDITION
OUTPUT VOLTAGE (RELEASED)			0.4V	SINKING 20 mA PER OUTPUT
OUTPUT LEAKAGE CURRENT (RELEASED)			20µA	LEAKAGE INTO SWITCH OUTPUT
OUTPUT SWITCHING TIME (SINKING 20 mA)			1.5 µSEC	10% TO 90%
RISE TIME 			0.5 µSEC	90% TO 10%
FALL TIME				

NOTE: THIS DEVICE IS NOT PROTECTED AGAINST HIGH ELECTRICAL NOISE. IF ERRATIC OPERATION OCCURS AFTER INSTALLATION, INSTALL A CAPACITOR ACROSS THE INPUT TERMINALS (0.1 MFD). IF ERRATIC OPERATION CONTINUES, YOU MAY HAVE TO USE THE INDUSTRIAL DEVICES THAT MICRO SWITCH MANUFACTURES. PLEASE CONTACT YOUR LOCAL FIELD REPRESENTATIVE FOR INFORMATION.

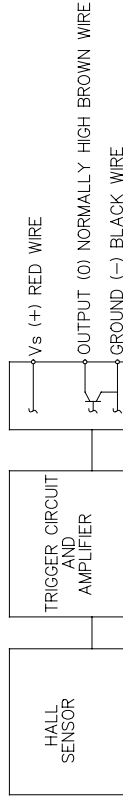

BLOCK DIAGRAM SHOWING CURRENT SINKING OUTPUTS

NOTES

- 1 FLUX ENTERING THE SOUTH POLE OF THE MAGNET WILL OPERATE THE SENSOR WHEN MAGNET IS POSITIONED AS SHOWN IN FIGURE 2. THIS ASSUMES THE CONVENTION THAT THE DIRECTION OF THE EXTERNAL FLUX OF A MAGNET IS FROM THE NORTH TO THE SOUTH POLE OF THE MAGNET.
- 2 22 GAUGE IRRADIATED PVC INSULATED CONDUCTORS WITH THERMOPLASTIC POLYURETHANE JACKET DATE CODE LOCATED IN THIS AREA
- 3 FROM -40°C TO 100°C AND 4.5 TO 24 VOLTS
- 4 CATALOG LISTING LOCATED IN THIS AREA
- 5 SENSITIVE AREA IS LOCATED .050 BEHIND THE SENSING FACE AT 24°±2°
- 6 Vs IS THE UNREGULATED SUPPLY VOLTAGE
- 7 JACKET IS CUT BACK 1.37 INCHES FROM FREE END OF LEADS
- 8
- 9

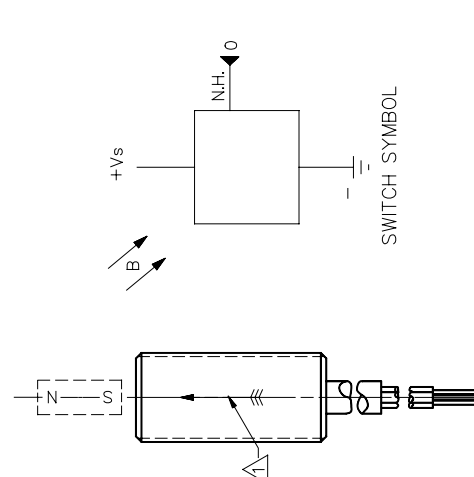
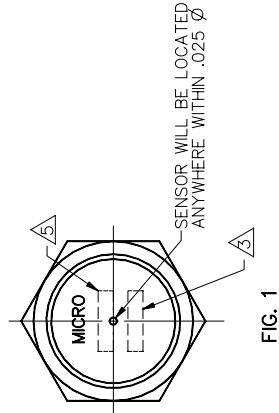
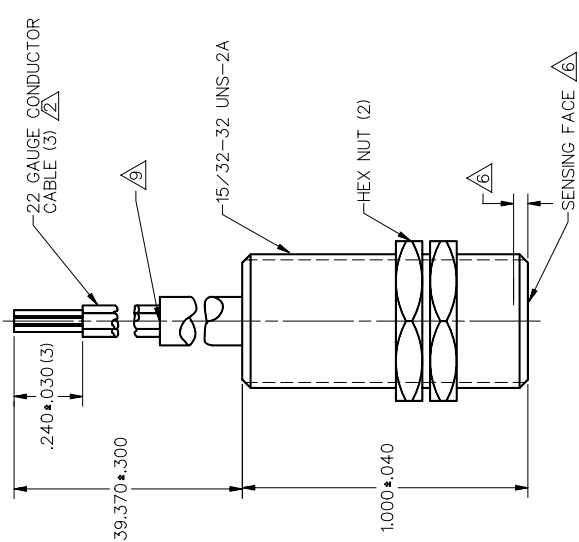



FIG. 2 OPERATE

THIRD ANGLE PROJECTION	
SCALE	3:1
DO NOT SCALE PRINT	
UNLESS OTHERWISE SPECIFIED TOLERANCES ARE	
ONE PLACE (.)	±.030
TWO PLACES (00)	±.015
THREE PLACES (000)	±.005
ANGLES	±
WEIGHT	

THIS DRAWING COVERS A PROPRIETARY ITEM AND IS THE PROPERTY OF MICRO SWITCH, A DIVISION OF HONEYWELL. THIS DRAWING IS NOT TO BE COPIED OR USED WITHOUT THE APPROVAL OF MICRO SWITCH.

MICRO SWITCH
a Honeywell Division

MAGNETICALLY OPERATED CYLINDRICAL HALL SWITCH

CATALOG LISTING
103SR13A-11

MASTER REDUCED

FED. SPE. CASE 91929

