

Features and Benefits

- Chopper stabilized amplifier stage
- New miniature package / thin, high reliability package
- Operation down to 3.5V
- CMOS for optimum stability, quality and cost

Applications

- Solid state switch
- Limit switch
- Current limit
- Interrupter
- Current sensing

Ordering Information

Part No.	Temperature Suffix	Package	Temperature Range
US5881	E	SO or UA	-40°C to 85°C Extended
US5881	L	SO or UA	-40°C to 150°C Automotive

*Contact factory or sales representative for legacy temperature options

Functional Diagram

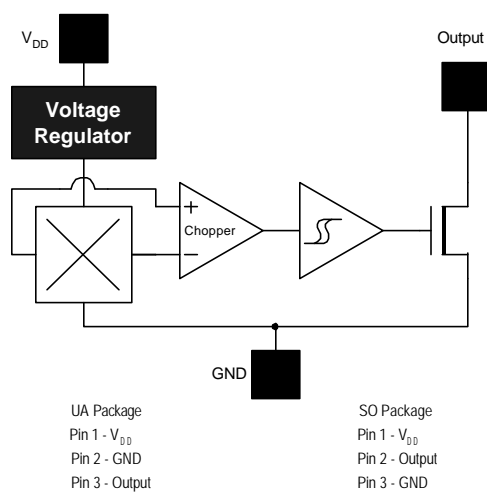

Description

The US5881 is a unipolar Hall effect sensor IC fabricated from mixed signal CMOS technology. It incorporates advanced chopper stabilization techniques to provide accurate and stable magnetic switch points. There are many applications for this sensor in addition to those listed above. The design, specifications and performance have been optimized for applications of solid state switches.

The output transistor will be switched on (B_{OP}) in the presence of a sufficiently strong South magnetic field facing the marked side of the package. Similarly, the output will be switched off (B_{RP}) in the presence of a weaker South field and remain off with "0" field. The SOT-23 device is reversed from the UA package. The SOT-23 output transistor will be switched on (B_{OP}) in the presence of a sufficiently strong North pole magnetic field subjected to the marked face.

Note: This is a static-sensitive device; please observe ESD precautions. Reverse V_{DD} protection is not included. For reverse voltage protection, a 100 Ω resistor in series with V_{DD} is recommended.

US5881 Electrical Specifications

Parameter	Symbol	Test Conditions	Min	Typ	Max	Units
Supply Voltage	V_{DD}	Operating	3.5		24	V
Supply Current	I_{DD}	$B < B_{RP}$	1.5	2.5	4.0	mA
Saturation Voltage	$V_{DS(on)}$	$I_{OUT} = 20\text{ mA}, B > B_{OP}$		0.4	0.5	V
Output Leakage	I_{OFF}	$B < B_{RP}, V_{OUT} = 20\text{V}$		0.01	5.0	μA
Output Rise Time	t_r	$V_{DD} = 12\text{V}, R_L = 1.1\text{k}\Omega, C_L = 20\text{pf}$		0.04		μs
Output Fall Time	t_f	$V_{DD} = 12\text{V}, R_L = 1.1\text{k}\Omega, C_L = 20\text{pf}$		0.18		μs

US5881 Magnetic Specifications

Parameter	Symbol	Test Conditions	Min	Typ	Max	Units
Operating Point ³	B_{OP}		15	25	30	mT
Release Point	B_{RP}		9.5	20	-	mT
Hysteresis	B_{hys}		2.0	4.3	5.5	mT

Notes:

- 1 mT = 10 Gauss.
- The SOT-23 device is reversed from the UA package. The SOT-23 output transistor will be switched on (BOP) in the presence of a sufficiently strong North pole magnetic field subjected to the markedface.
- At -40°C , maximum $B_{OP} = 35\text{ mT}$.

Absolute Maximum Ratings

Supply Voltage (Operating), V_{DD}	24V
Supply Current (Fault), I_{DD}	50mA
Output Voltage, V_{OUT}	24V
Output Current (Fault), I_{OUT}	50mA
Power Dissipation, P_D	100mW
Operating Temperature Range, T_A	-40°C to 150°C
Storage Temperature Range, T_S	-65°C to 150°C
Maximum Junction Temp, T_J	175°C
ESD Sensitivity (All Pins)	+/- 4KV

Melexis Inc. reserves the right to make changes without further notice to any products herein to improve reliability, function or design. Melexis does not assume any liability arising from the use of any product or application of any product or circuit described herein.

Performance Graphs

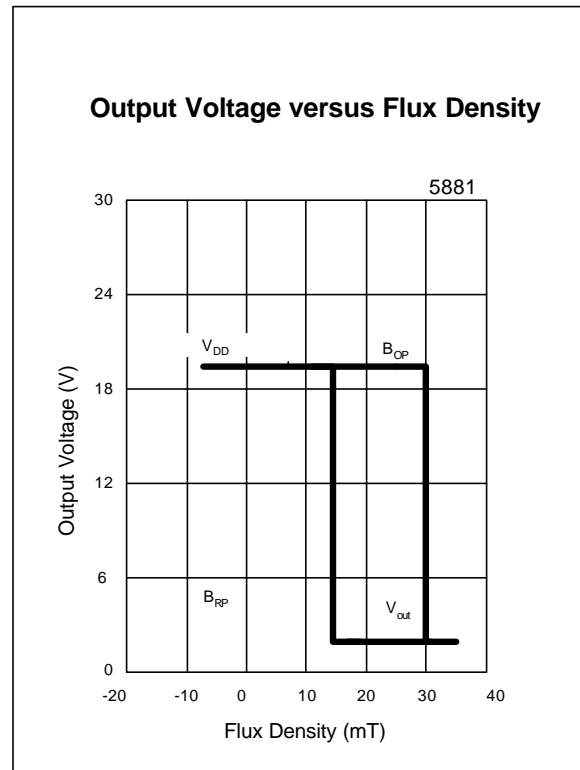
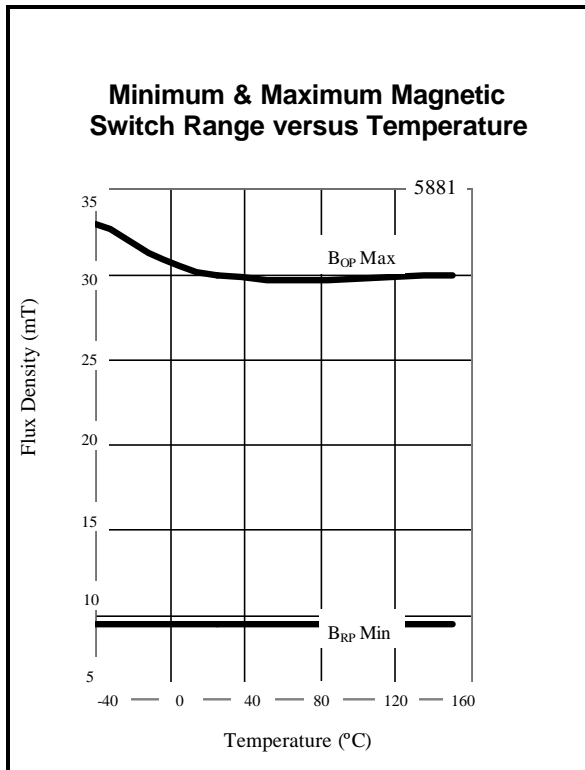
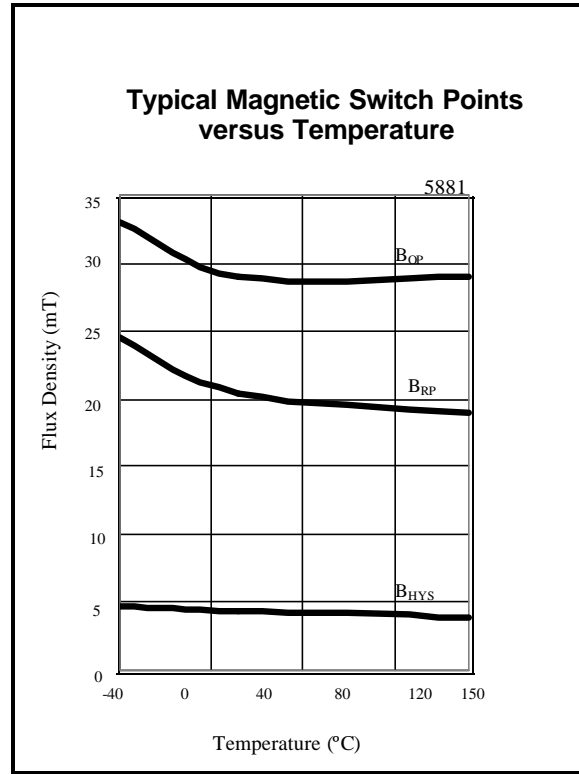
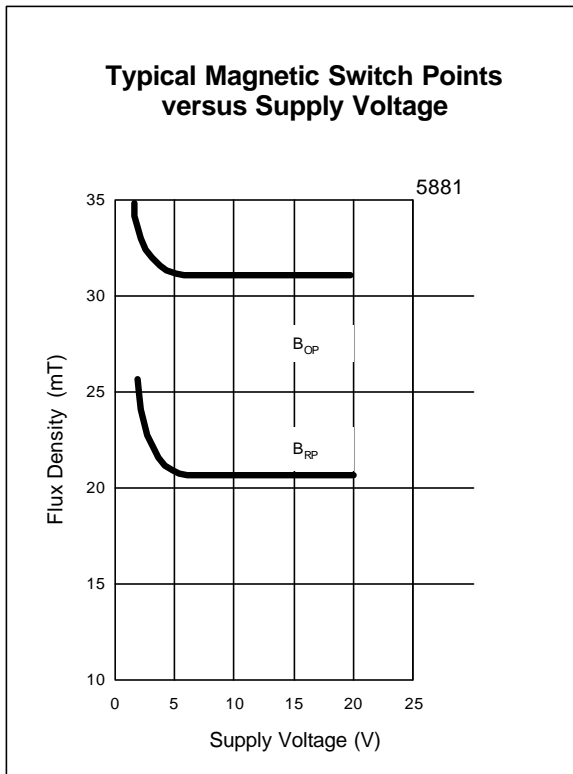

Performance Graphs

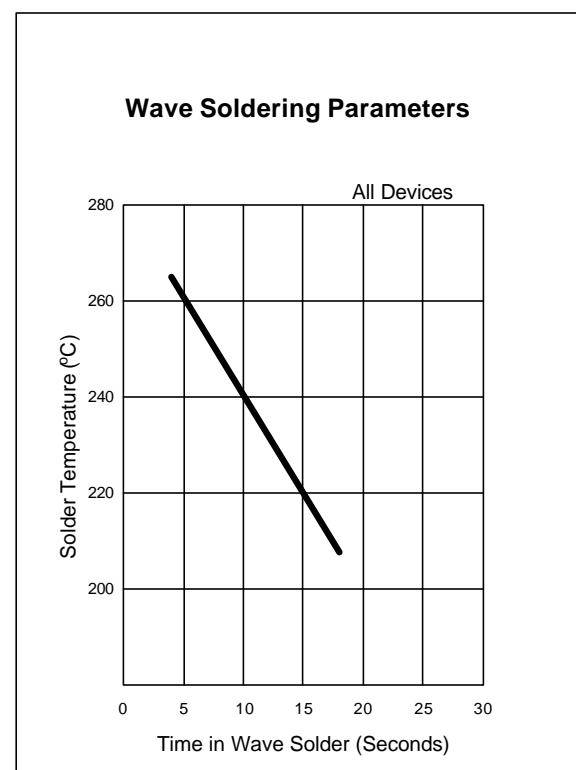
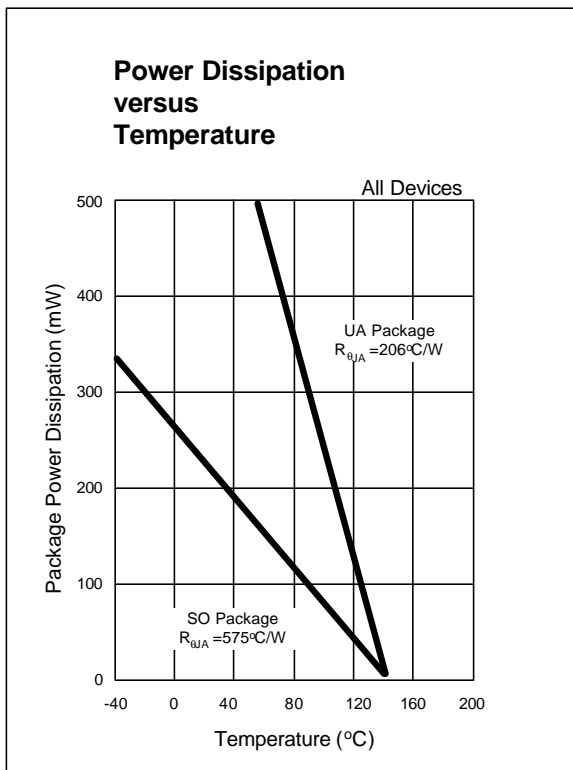
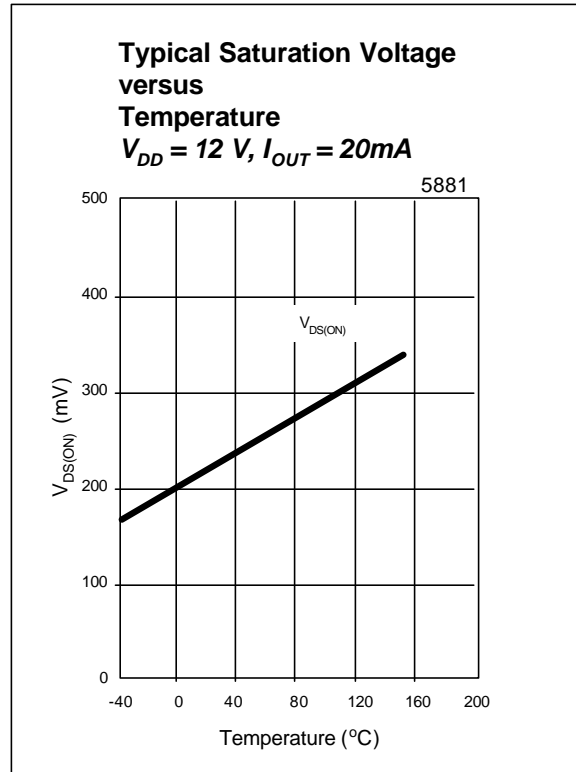
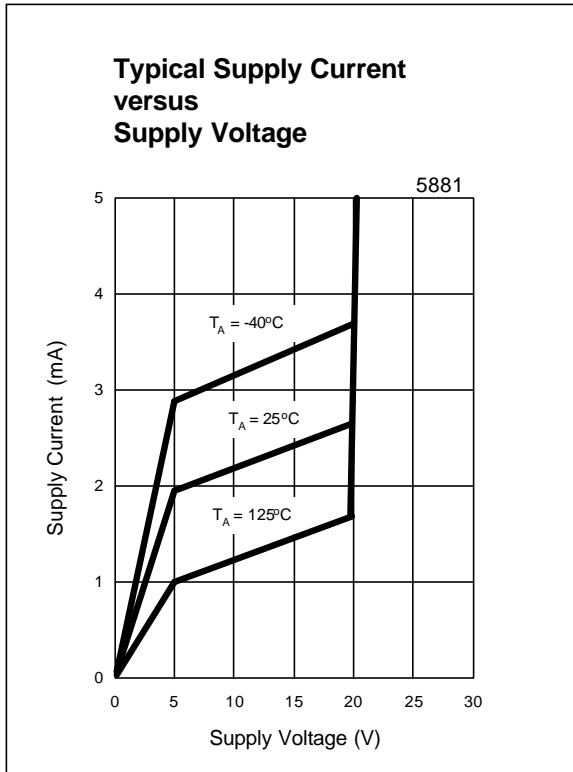

Unique Features

CMOS Hall IC Technology

The chopper stabilized amplifier uses switched capacitor techniques to eliminate the amplifier offset voltage, which, in bipolar devices, is a major source of temperature sensitive drift. CMOS makes this advanced technique possible.

The CMOS chip is also much smaller than a bipolar chip, allowing very sophisticated circuitry to be placed in less space. The small chip size also contributes to lower physical stress and less power consumption.

Installation

Consider temperature coefficients of Hall IC and magnetics, as well as air gap life time variations. Observe temperature limits during wave soldering.

Application Comments

If reverse supply protection is desired, use a resistor in series with the V_{DD} pin. The resistor will limit the supply current (Fault), I_{DD} , to 50 mA. For severe EMC conditions, use the application circuit below.

Applications Examples

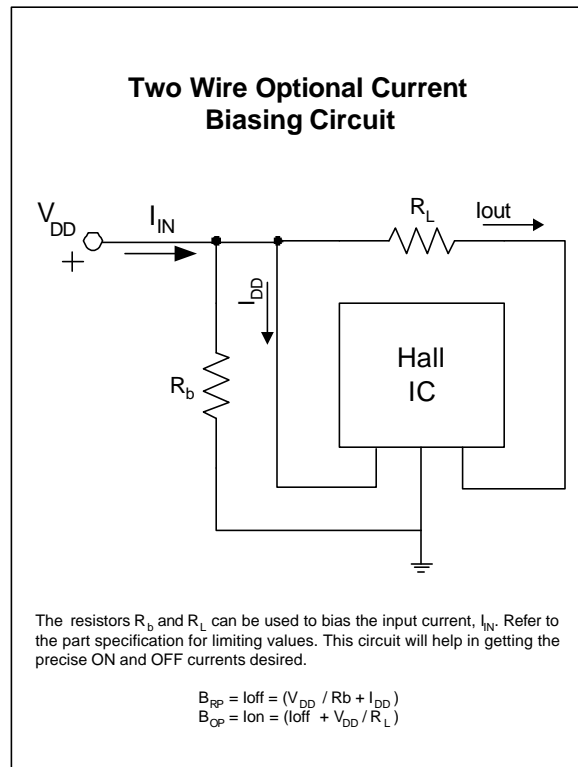
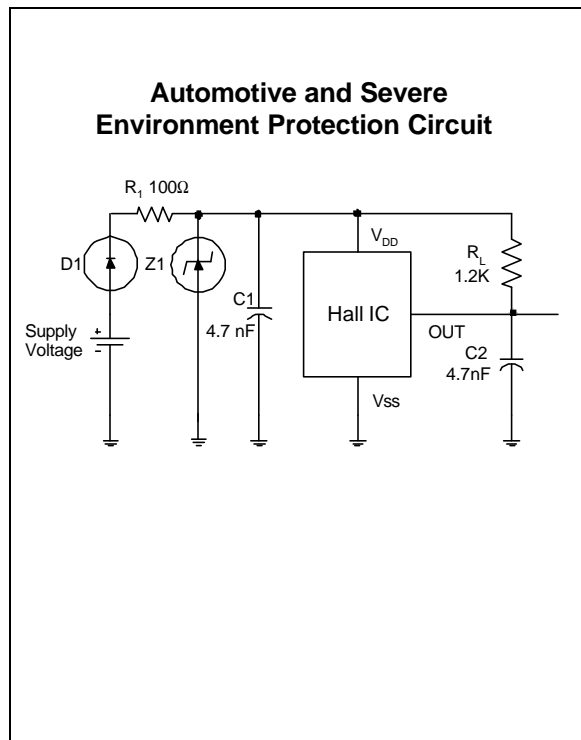

Physical Characteristics

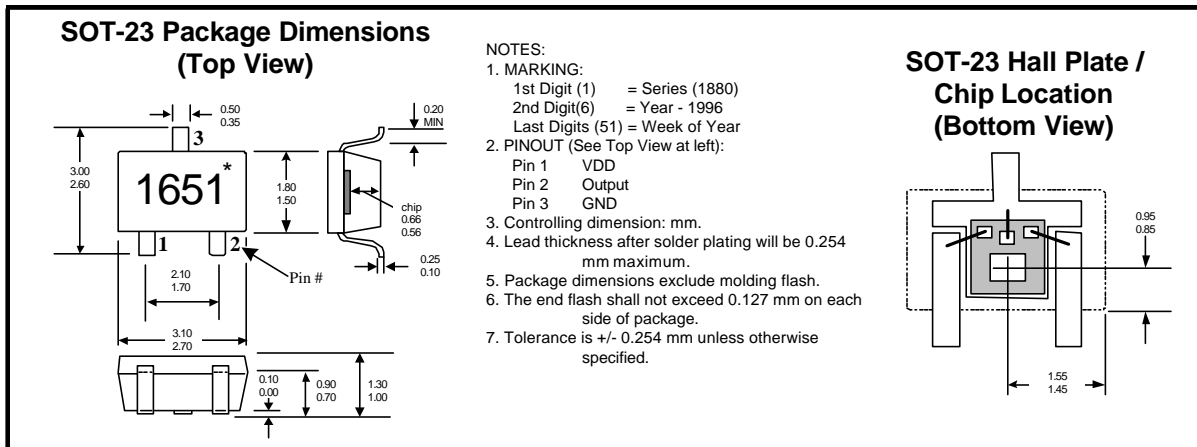
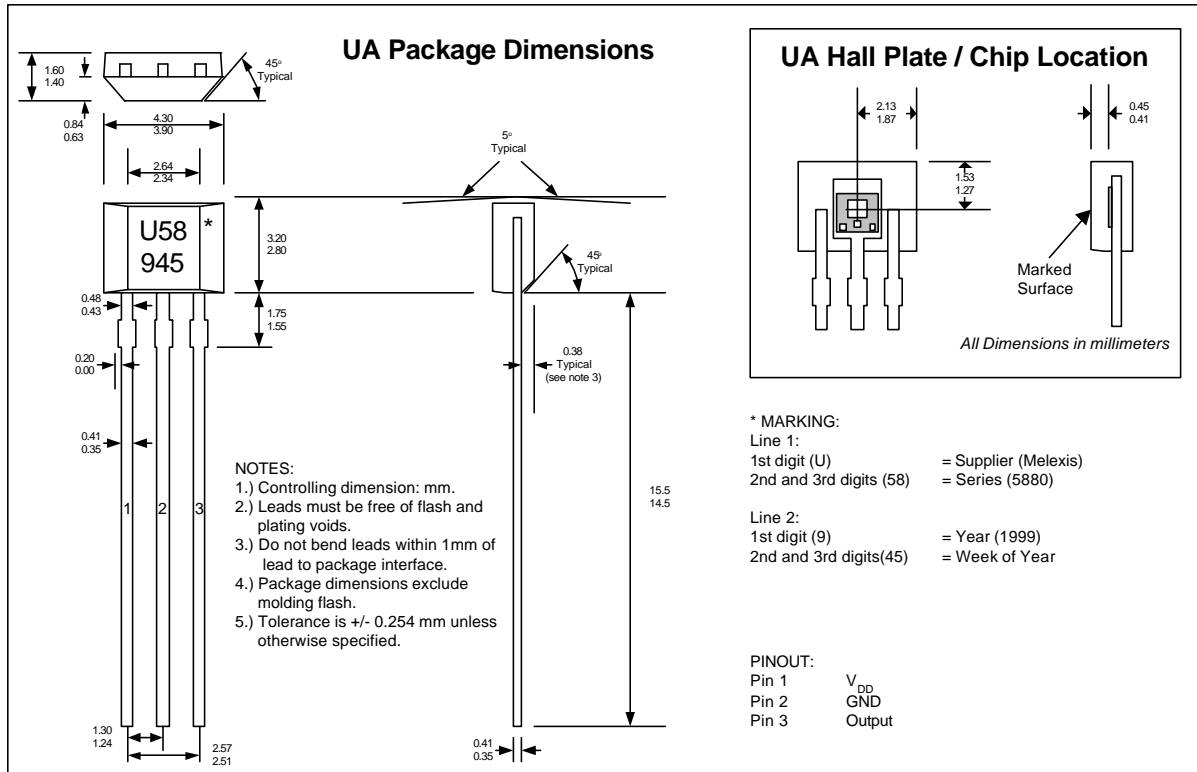

For the latest version of this document,
 Go to our website at:

WWW.melexis.com

Or for additional information

Contact Melexis Direct:

Europe and Japan

E-mail: sales_europe@melexis.com

Phone: 011-32-13-670-780

USA and rest of the world

E-mail: sales_usa@melexis.com

Phone: (603)-223-2362