

## ADL-Series Nanopower Digital Switches

### Key Features

- Ultraminiature 1.1 mm x 1.1 mm x 0.45 mm ULLGA package
- Precise Detection of Low Magnetic Fields
- Low Voltage Operation to 2.4 V
- Typical Power Consumption As Low As 72 nW at 2.4 V
- Digital Switch Output
- Continuously Operating or Duty-Cycled Versions



### Description

ADL-Series sensors are Giant Magnetoresistive (GMR) Digital Switches designed to run at low voltages and extremely low currents. The devices are manufactured with NVE's patented spintronic GMR technology for unmatched miniaturization, sensitivity, precision, and low power.

NVE's new ULLGA leadless package measures just 1.1 mm x 1.1 mm x 0.45 mm. Bare die (0.625 mm x 0.625 mm) are also available for extremely space-critical applications.

Configured as a magnetic "switch," the output turns on when the magnetic field is applied, and turns off when the field is removed. The applied magnetic field can be of either polarity, and the magnetic operate point is extremely stable over supply voltage and temperature.

The ICs consist of a GMR sensor element, CMOS signal processing circuitry to convert the analog sensor element output to a digital output, and optional oscillator and timing circuitry for power management duty cycling.

Internally duty cycled versions conserve power. Two different duty-cycle frequencies are available, offering a trade-off between update frequency and power consumption. An integrated latch ensures the output is available continuously. The continuously operating versions have a frequency response of 250 kHz.

ADL-Series Digital Switches are ideal for battery-powered devices such as gas and water meters, portable instruments, or anyplace where an extremely low power device is required. The continuously operating versions consume less than a milliwatt, and the duty-cycled versions consume less than a microwatt. The output is current-sinking and can sink up to 100 microamps.

Versions of this part with different magnetic characteristics and duty-cycle update frequencies are available. Please contact NVE for details.

**SB-00-017; last revised 9-21-09**

**Functional Block Diagrams**

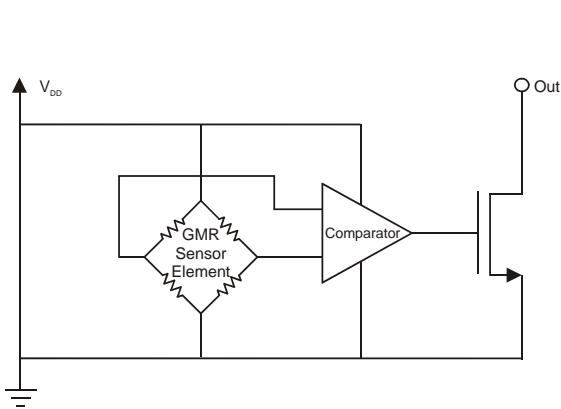

Continuously-operating versions  
(ADL9xx)

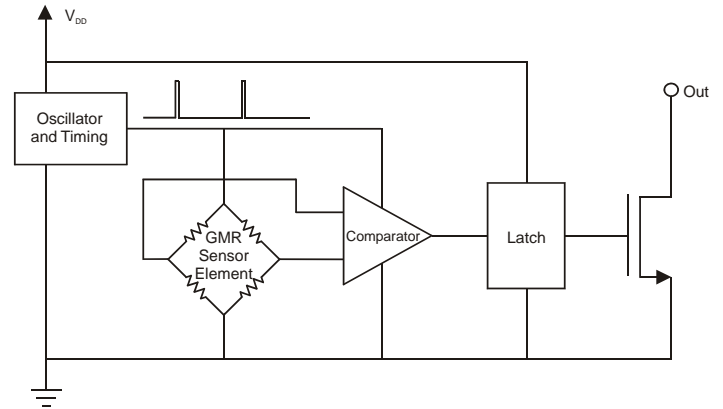

Duty-cycled versions  
(ADL0xx/ADL1xx)

**Operation**

The direction of magnetic field sensitivity is planar to the package. As the field varies in intensity, the digital output will turn on and off. The user must provide a pull-up resistor on the output terminal.

**Sensor Activation With a Permanent Magnet**

The diagrams below show two permanent magnet orientations that will activate the sensor in the direction of sensitivity (planar to the package):

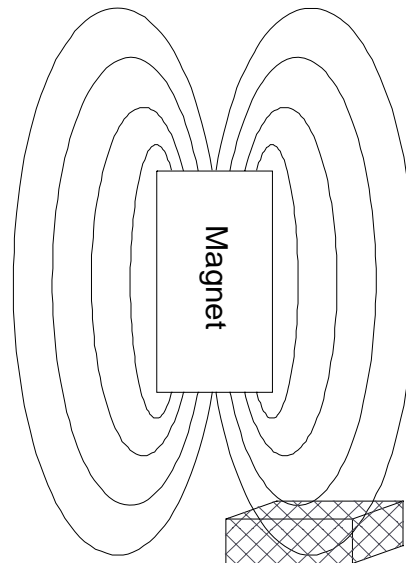
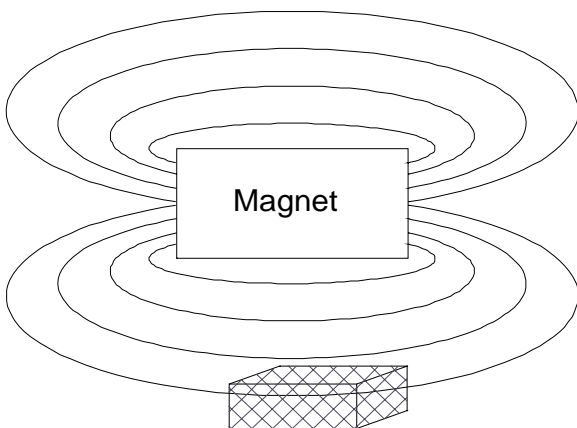

### Electrical and Magnetic Specifications

(specifications valid over all operating voltage and temperature ranges):

Parameter	Min.	Typ.	Max.	Units
Magnetic Operate Point (ADLx21)	15	20	25	Oersteds  <sup>(1)</sup>
Magnetic Operate Point (ADLx22)	30	40	50	Oersteds  <sup>(1)</sup>
Magnetic Operate Point (ADLx24)	21	28	34	Oersteds  <sup>(1)</sup>
Operate/Release Differential	2		14	Oersteds
Operating Voltage (V <sub>DD</sub> )	2.4	3.0	3.6	Volts
Quiescent Current at 2.4 V (ADL0xx)		0.080	0.160	μA
Quiescent Current at 2.4 V (ADL1xx)		0.030	0.060	μA
Quiescent Current at 2.4 V (ADL9xx)		35	50	μA
Quiescent Current at 3.6 V (ADL0xx)		0.200	0.350	μA
Quiescent Current at 3.6 V (ADL1xx)		0.115	0.160	μA
Quiescent Current at 3.6 V (ADL9xx)		85	120	μA
Peak Current During Sensor Sampling (3.0 V)		60	100	μA
Output Drive Current	100			μA
V <sub>OL</sub> at 100 μA Output Drive Current (V <sub>DD</sub> = 3.6 V)			0.20	Volts
Output Leakage Current			0.005	μA
Update Frequency (ADL0xx)	20	55		Hz
Update Frequency (ADL1xx)	10	30		Hz
Operating Frequency (ADL9xx)	250			kHz
Temperature Range of Operation	-40		125	°C

### Absolute Maximum Ratings

Parameter	Rating	Units
Applied Magnetic Field	Unlimited <sup>(2)</sup>	Oersteds
Supply Voltage	5.5	Volts
Output Off Voltage	5.5	Volts
Output Current	200	μA
Maximum Junction Temperature	+170	°C
Storage Temperature	-65 to +170	°C

#### Notes:

- 1 Oe (Oersted) = 1 Gauss in air = 0.1 mT
- 2 Large Magnetic Fields WILL NOT damage NVE GMR Sensors

**Performance Over Temperature and Power Supply Range**

Average current increases, but remains extremely low, over variations in supply voltage. The magnetic operate and release points are very stable over temperature and supply voltage. Update frequency increases as supply voltage increases.

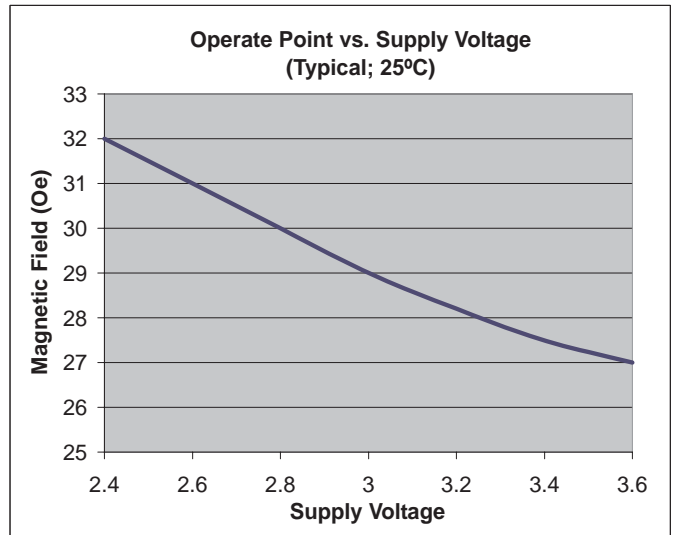
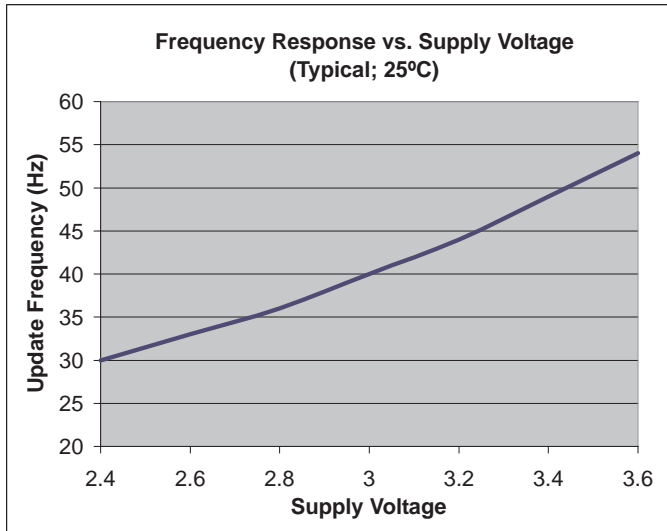
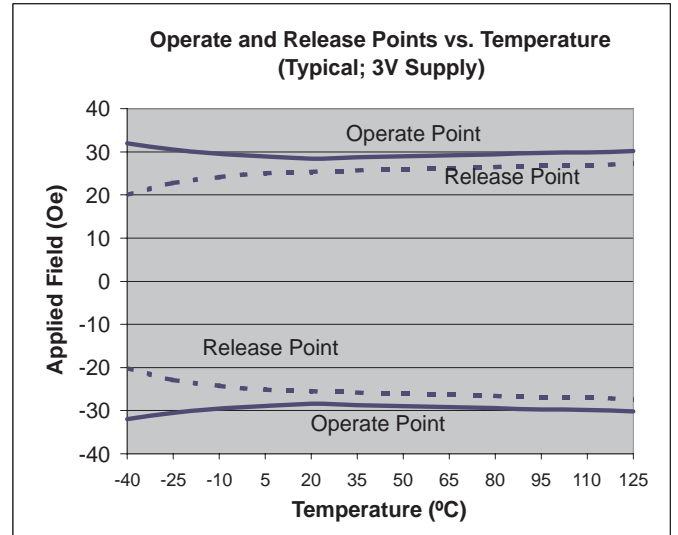
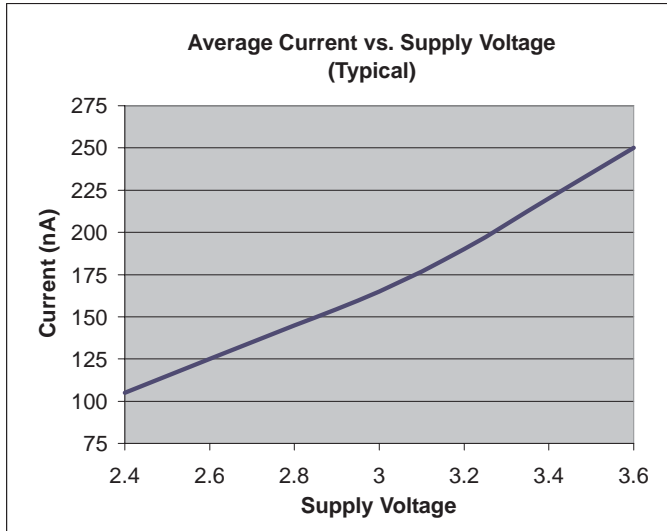

**Package Drawings, Dimensions, and Specifications:**

**4-Lead ULLGA Package**

1.1 mm x 1.1 mm x 0.45 mm; Lead Pitch 0.65 mm

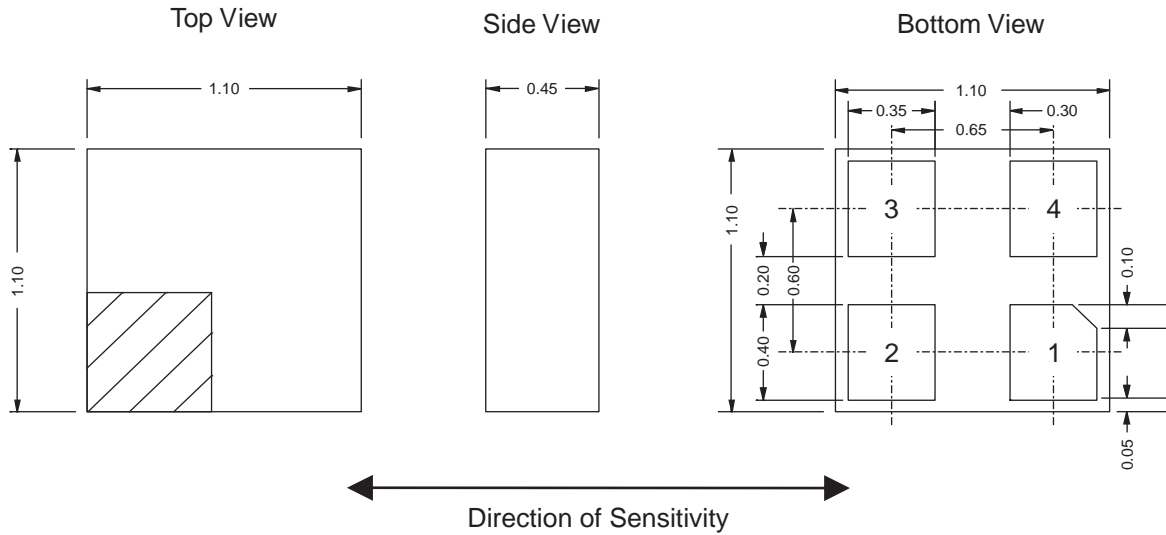

Dimensions in mm; ±0.10 mm

**Pinout:**

Pin 1	No Connect
Pin 2	V <sub>DD</sub>
Pin 3	Out
Pin 4	Ground

**Part Numbering**

The following example shows the ADL-Series part-numbering system:

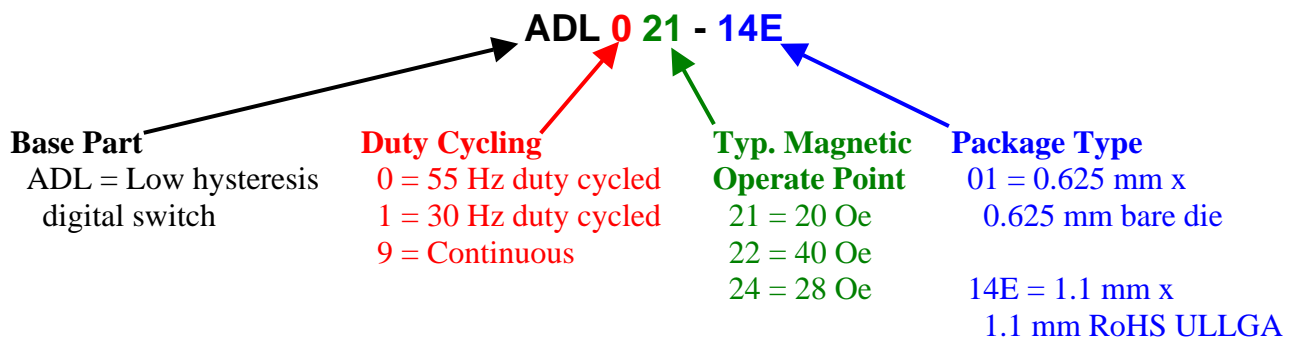

### Package Marking Codes:

Part Number	Mark
ADL021-14E	V
ADL022-14E	*
ADL024-14E	C
ADL121-14E	*
ADL122-14E	*
ADL124-14E	D
ADL921-14E	*
ADL922-14E	*
ADL924-14E	*

\*Marking not yet assigned

*The information provided by NVE Corporation is believed to be accurate. However, no responsibility is assumed by NVE Corporation for its use, nor for any infringement of patents, nor rights or licenses granted to third parties, which may result from its use. No license is granted by implication, or otherwise, under any patent or patent rights of NVE Corporation. NVE Corporation does not authorize, nor warrant, this product for use in life support devices or systems or other critical applications.*

***Specifications are subject to change without notice.***

SB-00-017; last revised 9-21-09