

Our range of Flow Switches are reed switch based devices which are manufactured in Acetal resin. These switches are designed for use in liquid flow systems up to 10 Bar pressure. Advanced design ensures minimal fluid flow restriction.



- **Maximum Operating Pressure 10 bar. (140 PSI)**
- **Low flow version available**
- **WRAS approval**
- **Temperature rated to 85°C (185°F)**

Electrical Specifications	All types
Contact form	N/O
Switching Power Max. VA	15
Switching Voltage AC Max.	240
Switching Voltage DC Max.	120
Switching Current Max. A	1.0

All ratings are for resistive load only.

Technical Specifications		FS15A	FS15LF	FS22A
Operate Flow Rate*	litres/min	2.0	0.90	3.75
	US gals/min.	0.53	0.24	0.99
Release Flow Rate**	litres/min	0.3	0.25	1.40
	US gals/min.	0.08	0.07	0.37

* The switch will have operated when the flow rate rises above this value.

** The switch will have released when the flow rate falls below this value.

Installation

Flow switches can be mounted horizontally or vertically. As the operating piston is returned to its original position by gravity the cap must always be upwards. Greater operate flow sensitivity is achieved with vertical installation. Supplied with 25cm Cable.

Mechanical Dimensions

All dimensions are in millimeters (inches)

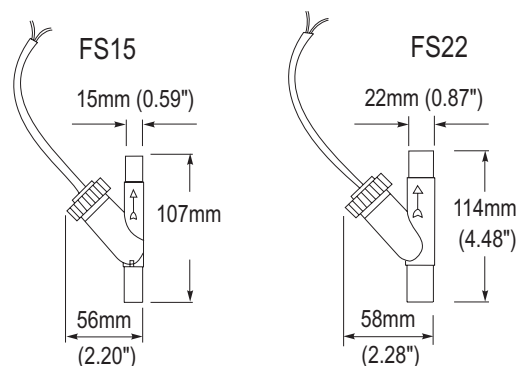

USA

Cynergy3 Components
2320 Paseo de las Americas, Suite 104
San Diego, CA 92154
Sales & Tech Support (866) 258-5057
Email: sales@cynergy3.com

EUROPE - UK

Cynergy3 Components Ltd.
7 Cobham Road
Ferndown Industrial Estate
Wimborne, Dorset BH21 7PE
Telephone +44 (0) 1202 897969
Fax +44 (0) 1202 891918
Email:sales@cynergy3.com