

# Flow Switches

## Series **PF2**, **IF**

### Digital Flow Switch

Digital Flow Switch for Air: **Series PF2A** ..... Refer to page 16-11-7.

Digital Flow Switch for Water: **Series PF2W** ..... Refer to page 16-11-17.

Digital Flow Switch for Deionized Water and Chemicals: **Series PF2D** ..... Refer to page 16-11-37.

ZSE  
ISE

PSE

ZSE<sub>1</sub>

PS

ZSE<sub>2</sub>

ZSP

ISA2

IS

ZSM

PF2

IF

Data

### Mechanical Flow Switch

#### Diaphragm Style Flow Switch: **Series IFW**

Model	Flow rate measuring range (ℓ/min)	Contacts	Port size (Rc, NPT, G)	Page
<b>IFW510</b>	1 to 10	1ab	3/8, 1/2, 3/4	16-12-1
<b>IFW520</b>	10 to 20			
<b>IFW550</b>	20 to 50			

#### Paddle Style Flow Switch: **Series IF3**

Model	Flow rate measuring range (ℓ/min)	Contacts	Port size (Rc, NPT, G)	Page
<b>1F3</b> <input type="checkbox"/> <b>0</b>	14 to 60	1ab	3/4	16-12-6
<b>1F3</b> <input type="checkbox"/> <b>1</b>	20 to 150		1	
<b>1F3</b> <input type="checkbox"/> <b>3</b>	36 to 2600		1	



# Flow Switches Precautions 1

Be sure to read before handling.

## Design and Selection

### Warning

- 1. Make sure to use a switch by the specified voltage.**  
Use of a switch outside the range of the specified voltage can cause not only malfunction and damage of the switch, but also electrocution and fire.
- 2. Never use such a load, which exceeds the maximum allowable load.**  
It may result in a damage to a switch.
- 3. Since the type of fluid varies depending on the product, make sure to verify the specifications.**  
Never use flammable gases or fluids, since the switch is not explosion proof construction. It may result in a fire.

#### [For air]

- 4. Make sure to use a switch within the specified flow rate for measurement and the maximum operating pressure.**  
Operating beyond the specified flow rate and operating pressure can damage the switch.  
If using a switch by exceeding the maximum operating pressure, switch is damaged.

#### [For water]

- 5. Make sure to use a switch within the specified flow rate for measurement and the maximum operating pressure.**  
Operating beyond the specified flow rate and operating pressure can damage the switch.  
Damage to the switch may occur if the switch is subject to higher pressure than its designed limit.  
Avoid especially the application of pressure above specifications through a water hammer.  
<Countermeasure examples>
  - Use a device such as a water hammer relief valve to slow the valve's closing speed.
  - Absorb an impact pressure by using a rubber material piping such as a rubber hose and an accumulator.
  - Keep the piping length as short as possible.

## Mounting

### Warning

- 1. Mount a switch by observing the proper tightening torque.**

When a switch is tightened beyond the specified tightening torque, a switch may be damaged. On the other hand, tightening below the specified tightening torque may cause the installation screws to come loose during operation.

Thread	Proper tightening torque (N·m)
1/8	7 to 9
1/4	12 to 14
3/8	22 to 24
1/2	28 to 30
3/4	28 to 30
1	36 to 38

- 2. Apply a wrench only to the metal part of the piping when installing the flow switch in the system piping.**

Do not apply a wrench to the plastic part of the main housing of the switch.

- 3. Monitor the flow direction of the fluid.**

Install a switch in the direction as indicated on the body.

- 4. Remove solid foreign objects, etc. inside piping by air blow before connecting a switch with piping.**

- 5. Do not drop or bump.**

Do not drop, bump, or apply excessive impacts (490 m/s<sup>2</sup>) while handling. Although the external body of the switch (switch case) may not be damaged, the inside of the switch could be damaged and cause a malfunction.

- 6. Hold the body of a switch when handling.**

The tensile strength of the cord is 49 N. Applying a greater pulling force on it can cause a malfunction. When handling, hold the body of the switch—do not dangle it from the cord.

- 7. Do not use until you can verify that equipment can operate properly.**

Verify whether it is mounted correctly by running fluids or applying the electricity in order to conduct suitable function and leakage tests when mounting for the first time or after system repair or modification was made.

#### [For air]

- 8. Ever mount a switch in a place that will be used as a scaffold during piping.**

If an excessive weight is applied on a switch, switch may be damaged.

- 9. Be sure to allow straight pipe length that is minimum 8 times the port size upstream and downstream of the switch piping.**

Do not suddenly narrow the pipe size because doing so will disturb the flow speed distribution in the pipe, making it impossible to obtain the correct measurements.

#### [For water]

- 10. Never install a switch in such a place, where switch is used as a foothold in the piping.**

Damage may occur if an excessive load is applied to the switch. Especially when the switch supports the piping, do not apply a load of 15 N·m or more to the metal parts of the switch.



# Flow Switches Precautions 2

Be sure to read before handling.

## Wiring

### Warning

- 1. Verify the color and terminal number when wiring.**  
Incorrect wiring can cause a switch to be damaged and may result in a malfunction. Verify the color of wiring and the terminal number in the instruction manual when wiring.
- 2. Avoid repeatedly bending or stretching the lead wire.**  
Repeatedly applying bending stress or stretching force to the lead wire will cause it to break.
- 3. Confirm proper insulation of wiring.**  
Make sure that there is no wiring insulation (contact with other circuits, ground fault, improper insulation between terminals, etc.). Overcurrent is flown and may result in a damage.

## Operating Environment

### Warning

- 1. Never use in an environment, where explosive gases are used.**  
The switches do not have an explosion-proof rating. Never use in an environment, where explosive gases are used, as this may cause a serious explosion.
- 2. Mount a switch in such locations, where no vibration or shock (less than 98 m/s<sup>2</sup>) is affected.**

[For air]

- 3. Use the switch within the specified fluid and ambient temperature range.**  
Fluid and ambient temperatures are 0° to 50°C. Take measures to prevent freezing fluid when below 5°C, since this may cause damage to a switch and lead to a malfunction. The installation of an air dryer is recommended for eliminating condensate and moisture.  
Never use a switch in an environment, where temperature changes drastically even within the allowable ambient temperature range.

## Maintenance

### Warning

- 1. Perform periodical inspections to ensure proper operation of the switch.**  
Unexpected malfunctions and wrong operations may not secure the safety.
- 2. Use caution when using a switch for an interlock circuit.**  
When a pressure switch is used for an interlock circuit, devise a multiple interlock system to prevent trouble or malfunctioning. Verify the operation of the switch and interlock function on a regular basis.
- 3. Do not disassemble or modify the main body.**

## Fluid

### Warning

- 1. Check regulators and the flow adjustment valves before introducing the fluid.**

If pressure or flow rate beyond the specified range are applied to the switch, the sensor unit may be damaged.

[For air]

- 2. Fluids for measurement for this digital flow switch are nitrogen and air.**  
Please note that accuracy cannot be guaranteed when other fluids are used.

- 3. Never use flammable fluids.**

- 4. Install a filter or mist separator on the upstream side when there is a possibility of condensate and foreign matter being mixed in with the fluid.**

The rectifying device built into the switch will be clogged up and accurate measurement will no longer be possible.

[For water]

- 5. Never use flammable fluids.**
- 6. Install a filter in the inlet side when it is likely for solid foreign objects to get mixed with fluids.**

ZSE□  
ISE□

PSE

ZSE<sub>1</sub>□

PS

ZSE<sub>2</sub>□

ZSP

ISA2

IS□

ZSM

PF2□

IF□

Data

# Digital Flow Switch

## Series PF2A/PF2W

For Air For Water



For Air Series PF2A



For Water Series PF2W

- 1 Flow rate setting and monitoring are possible with the digital display.
- 2 Two types for different applications Integrated and remote type displays
- 3 Three types of output: Switch, accumulated pulse, and analog outputs.
- 4 Switching from real-time flow rate to accumulated flow is possible.
- 5 Two independent flow rate settings are possible.
- 6 Water resistant construction conforming to IP65

Flow rate measurement range (l/min)

For Air	For Water	For High Temperature Fluid (Water 90°C)
1 to 10	0.5 to 4	0.5 to 4
5 to 50	2 to 16	2 to 16
10 to 100	5 to 40	5 to 40
20 to 200	10 to 100	
50 to 500		
150 to 3000		
300 to 6000		
600 to 12000		

- ZSE
- ISE
- PSE
- SE3
- PS
- SE<sub>1</sub>
- ZSP
- ISA2
- IS
- ZSM
- PF2
- IF
- Data

### Application examples

Flow control of N<sub>2</sub> gas to prevent detection camera shimmering and lead frame oxidation

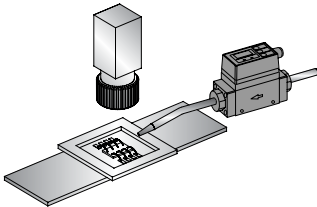

Flow control of cooling water for wafer temperature regulation and high frequency electric power supply

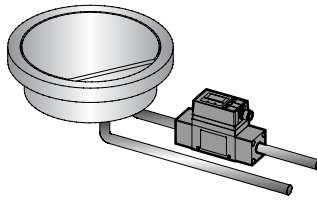

Flow control of pressurized cooling water for welding gun

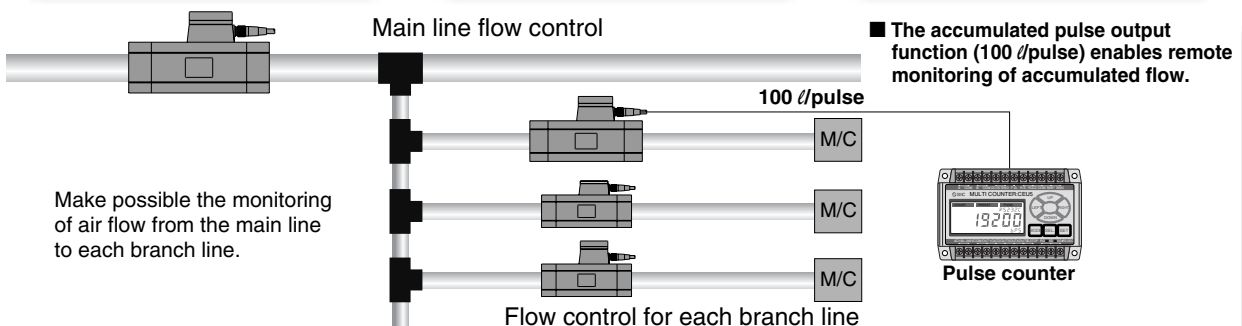
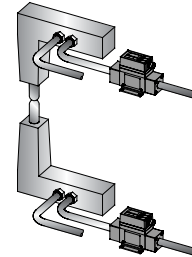

# Series Variation

## Series PF2A, PF2W

### For Air Series PF2A

P. 16-11-7



50 ℓ/min  
10 ℓ/min



500 ℓ/min  
200 ℓ/min  
100 ℓ/min



12000 ℓ/min  
6000 ℓ/min  
3000 ℓ/min

Integrated display type	Remote type		Flow rate measurement range ℓ/min	Output specifications			Port size (Rc, NPT, G)						
	Display unit	Sensor unit		Switch output	Analog output	Accumulated pulse output	1/8	1/4	3/8	1/2	1	1 1/2	2
PF2A710	PF2A30□	PF2A510	1 to 10	●	●	●	●	●					
750		550	5 to 50	●	●	●	●	●					
711	31□	511	10 to 100	●	●	●			●				
721		521	20 to 200	●	●	●			●				
751		551	50 to 500	●	●	●			●				
703H	-	-	150 to 3000	●	●	●				●			
706H			300 to 6000	●	●	●					●		
712H			600 to 12000	●	●	●						●	

● : Output from integrated display type and remote display unit type  
● : Output from remote sensor unit type

### For Water Series PF2W

P. 16-11-17



16 ℓ/min  
4 ℓ/min



40 ℓ/min



100 ℓ/min

Integrated display type	Remote type		Flow rate measurement range ℓ/min	Output specifications			Port size (Rc, NPT, G)			
	Display unit	Sensor unit		Switch output	Analog output	Accumulated pulse output	3/8	1/2	3/4	1
PF2W704	PF2W30□	PF2W504	0.5 to 4	●	●	●	●	●		
720		520	2 to 16	●	●	●	●	●		
740	33□	540	5 to 40	●	●	●		●	●	
711		511	10 to 100	●	●	●			●	●

● : Output from integrated display type and remote display unit type  
● : Output from remote sensor unit type

### For High Temperature Fluid (Water 90°C)

### Series PF2W

P. 16-11-26



Integrated display type	Remote type		Flow rate measurement range ℓ/min	Output specifications			Port size (Rc, NPT, G)		
	Display unit	Sensor unit		Switch output	Analog output	Accumulated pulse output	3/8	1/2	3/4
PF2W704T	PF2W30□	PF2W504T	0.5 to 4	●	●	●	●	●	
720T		520T	2 to 16	●	●	●	●	●	
740T		540T	5 to 40	●	●	●		●	●

● : Output from integrated display type and remote display unit type  
● : Output from remote sensor unit type



For details about certified products conforming to international standards, visit us at [www.smcworld.com](http://www.smcworld.com).

# Digital Flow Switch For Air Series PF2A



## How to Order

Integrated display type

PF2A7 10 — [ ] 01 — 27 [ ] — [ ]

### Flow rate range

10	1 to 10 $\ell$ /min
50	5 to 50 $\ell$ /min
11	10 to 100 $\ell$ /min
21	20 to 200 $\ell$ /min
51	50 to 500 $\ell$ /min

### Thread type

Nil	Rc
N	NPT
F	G

### Port size

Symbol	Port size	Flow rate ( $\ell$ /min)					Applicable model
		10	50	100	200	500	
01	1/8	●	●				PF2A710, PF2A750
02	1/4	●	●				
03	3/8			●	●		PF2A711, PF2A721
04	1/2					●	PF2A751

### Wiring specifications

Nil	3 m lead wire with connector
N	Without lead wire

### Unit specifications

Nil	With unit switching function
M	Fixed SI unit (Note)

Note) Fixed unit:  
Real-time flow rate:  $\ell$ /min  
Accumulated flow:  $\ell$

### Output specifications

Symbol	Output specifications	Applicable model
27	NPN open collector 2 outputs	PF2A710, PF2A750 PF2A711, PF2A721, PF2A751
67	PNP open collector 2 outputs	PF2A710, PF2A750 PF2A711, PF2A721/PF2A751

ZSE

ISE

PSE

ZSE3

PS

ZSE1

ZSE2

ZSP

ISA2

IS

ZSM

PF2

IF

Data

## Specifications

Model		PF2A710	PF2A750	PF2A711	PF2A721	PF2A751
Measured fluid		Air, Nitrogen				
Flow rate measurement range		0.5 to 10.5 $\ell$ /min	2.5 to 52.5 $\ell$ /min	5 to 105 $\ell$ /min	10 to 210 $\ell$ /min	25 to 525 $\ell$ /min
Set flow rate range		0.5 to 10.5 $\ell$ /min	2.5 to 52.5 $\ell$ /min	5 to 105 $\ell$ /min	10 to 210 $\ell$ /min	25 to 525 $\ell$ /min
Flow rate measuring range		1 to 10 $\ell$ /min	5 to 50 $\ell$ /min	10 to 100 $\ell$ /min	20 to 200 $\ell$ /min	50 to 500 $\ell$ /min
Minimum set unit		0.1 $\ell$ /min	0.5 $\ell$ /min	1 $\ell$ /min	2 $\ell$ /min	5 $\ell$ /min
Accumulated pulse flow rate exchange value (Pulse width: 50 ms)		0.1 $\ell$ /pulse	0.5 $\ell$ /pulse	1 $\ell$ /pulse	2 $\ell$ /pulse	5 $\ell$ /pulse
Display unit	Real-time flow rate	$\ell$ /min, CFM x 10 <sup>-2</sup>			$\ell$ /min, CFM x 10 <sup>-1</sup>	
	Accumulated flow	$\ell$ , ft <sup>3</sup> x 10 <sup>-1</sup>				
Operating fluid temperature		0 to 50°C				
Linearity		±5% F.S. or less				
Repeatability		±1% F.S. or less			±2% F.S. or less	
Temperature characteristics		±3% F.S. or less (15 to 35°C, based on 25°C), ±5% F.S. or less (0 to 50°C, based on 25°C)				
Current consumption (No load)		150 mA or less		160 mA or less		170 mA or less
Weight (Note 3)		250 g			290 g	
Port size (Rc, NPT, G)		1/8, 1/4		3/8		1/2
Detection type		Heater type				
Display		3-digit, 7-segment LED				
Operating pressure range		-50 kPa to 0.5 MPa		-50 kPa to 0.75 MPa		
Proof pressure		1.0 MPa				
Accumulated flow range		0 to 999999 $\ell$				
Output (Note 4) specifications	Switch output	NPN open collector	Maximum load current: 80 mA; Internal voltage drop: 1 V or less (With load current of 80 mA); Maximum applied voltage: 30 V; Two outputs			
		NPN open collector	Maximum load current: 80 mA; Internal voltage drop: 1.5 V or less (With load current of 80 mA); Two outputs			
Accumulated pulse output		NPN or PNP open collector (same as switch output)				
Indicator light		Lights up when output is ON OUT1: Green; OUT2: Red				
Response time		1sec. or less				
Hysteresis		Hysteresis mode: Variable (can be set from 0). Window comparator mode: 3-digit fixed (Note 5)				
Power supply voltage		12 to 24 VDC (Ripple ±10% or less)				
Enclosure		IP65				
Operating temperature range		Operating: 0 to 50°C, Stored: -25 to 85°C (No condensation or freezing)				
Withstand voltage		1000 VAC for 1 min. between external terminal and case				
Insulation resistance		50 M $\Omega$ (500 VDC) between external terminal and case				
Vibration resistance		10 to 500 Hz at whichever is smaller: 1.5 mm amplitude or 98 m/s <sup>2</sup> acceleration, in X, Y, Z directions for 2 hrs. each (De-energized)				
Impact resistance		490 m/s <sup>2</sup> in X, Y, Z directions 3 times each				
Noise resistance		1000 Vp-p, Pulse width 1 $\mu$ s, Rise time 1 ns				

Note 1) For digital flow switch with unit switching function. (Fixed SI unit [ $\ell$ /min, or  $\ell$ , m<sup>3</sup> or m<sup>3</sup> x 10<sup>3</sup>] will be set for switch type without the unit switching function.)

Note 2) Flow rate display can be switched between the basic condition of 0°C, 101.3 kPa and the standard condition (ANR) of 20°C, 101.3 kPa, and 65% RH.

Note 3) Without lead wire.

Note 4) Switch output and accumulated pulse output can be selected during initial setting.

Note 5) Window comparator mode — Since hysteresis will reach 3 digits, keep P\_1 and P\_2 or n\_1 and n\_2 apart by 7 digits or more. (In case of output OUT2, n\_1, 2 to be n\_3, 4 and P\_1, 2 to be P\_3, 4.)

Note 6) The flow switch is conformed to CE mark.



# Series PF2A

## Flow Characteristics (Pressure loss)

PF2A710/510

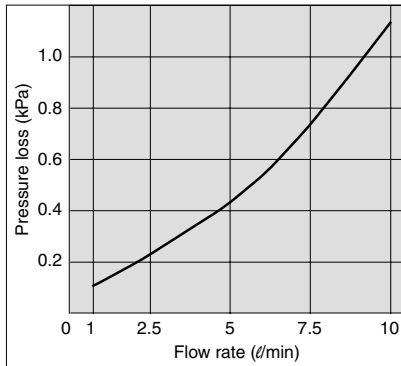

PF2A750/550

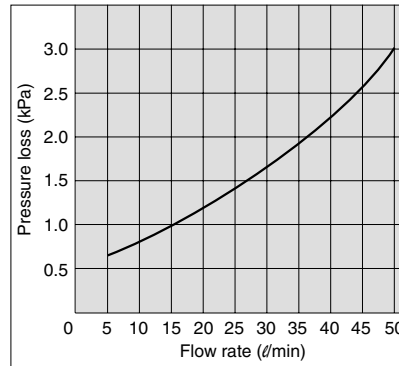

PF2A711/511

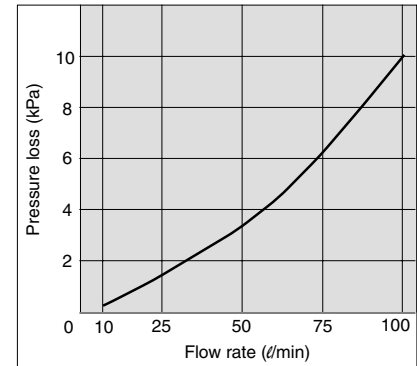

PF2A721/521

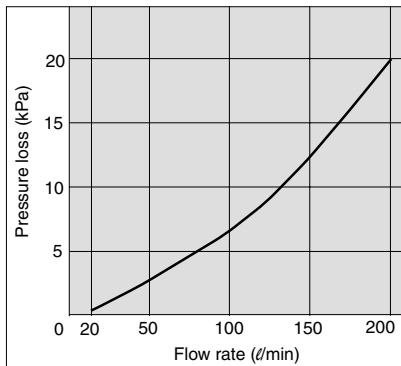

PF2A751/551

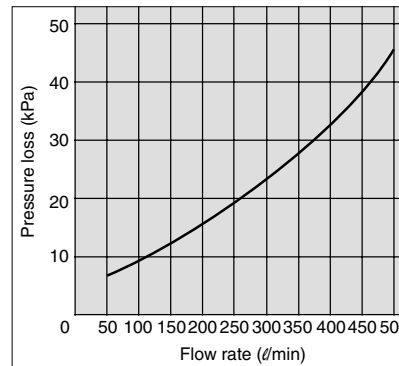

## Sensor Unit Construction

PF2A710/750  
PF2A510/550

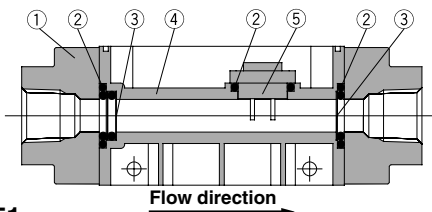

### Component Parts

No.	Description	Material
①	Attachment	ADC
②	Seal	NBR
③	Mesh	Stainless steel
④	Body	PBT
⑤	Sensor	PBT

PF2A711/721/751  
PF2A511/521/551

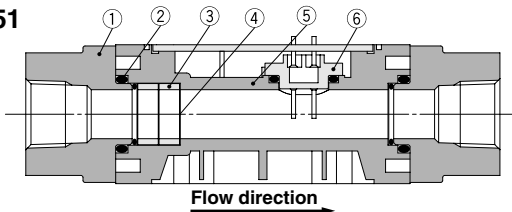

### Component Parts

No.	Description	Material
①	Attachment	ADC
②	Seal	NBR
③	Spacer	PBT
④	Mesh	Stainless steel
⑤	Body	PBT
⑥	Sensor	PBT

## Operating Unit Descriptions

### RESET Buttons

Press the ▲ and ▼ buttons simultaneously to activate the RESET function. This clears the unit when an abnormality occurs and resets the accumulated flow display to "0".

### Output (OUT1) Indicator: Green

Lights up when OUT1 is ON. Blinks when an overcurrent error occurs on OUT1.

### Output (OUT2) Indicator: Red

Lights up when OUT2 is ON. Blinks when an overcurrent error occurs on OUT2.

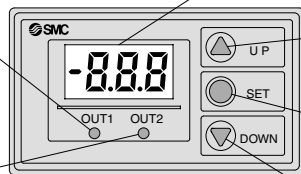

### LED Display

Displays the real-time flow rate, accumulated flow, and set value. The ■ mark blinks when the accumulated flow is being measured.

### UP Button (▲ Button)

Use this button to increase a set value.

### SET Button (● Button)

Use this button to change a set value or any of the modes.

### DOWN Button (▼ Button)

Use this button to decrease a set value.

## Connectors

Connectors shown below are applicable (female contact).

Contact each manufacturer for details.

Connector size	Number of pins	Manufacturer	Applicable series
M12	4	Correns Corporation	VA-4D
		OMRON Corporation	XS2
		Yamatake Corporation	PA5-4I
		Hirose Electric Co., Ltd.	HR24
		DDK Ltd.	CM01-8DP4S

## Dimensions: Integrated Display Type for Air

### PF2A710/750

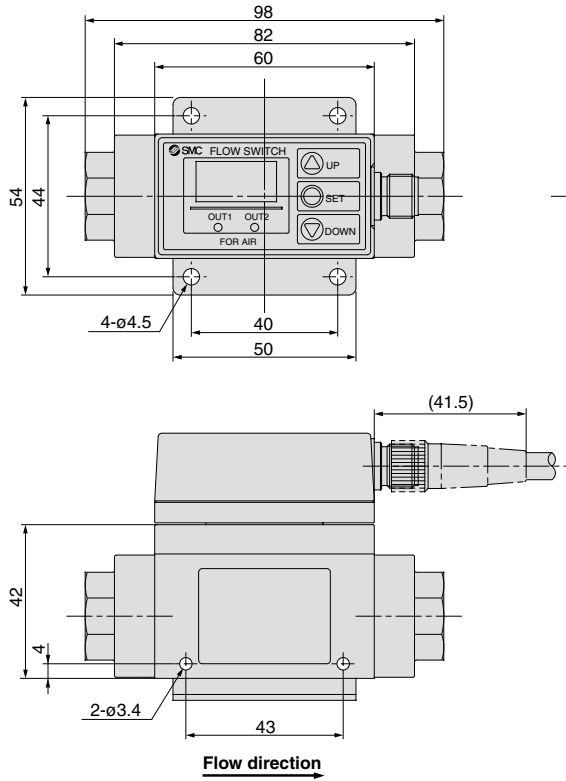

### Internal circuit and wiring example

① to ④ are terminal numbers.

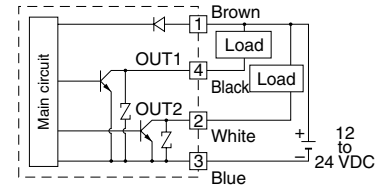

PF2A7□□-□□-27□(-M)

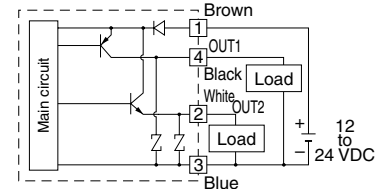

PF2A7□□-□□-67□(-M)

- ZSE□
- ISE□
- PSE
- SE3
- PS
- SE<sub>1</sub>
- ZSP
- ISA2
- IS□
- ZSM
- PF2□**
- IF□
- Data

### PF2A711/721/751

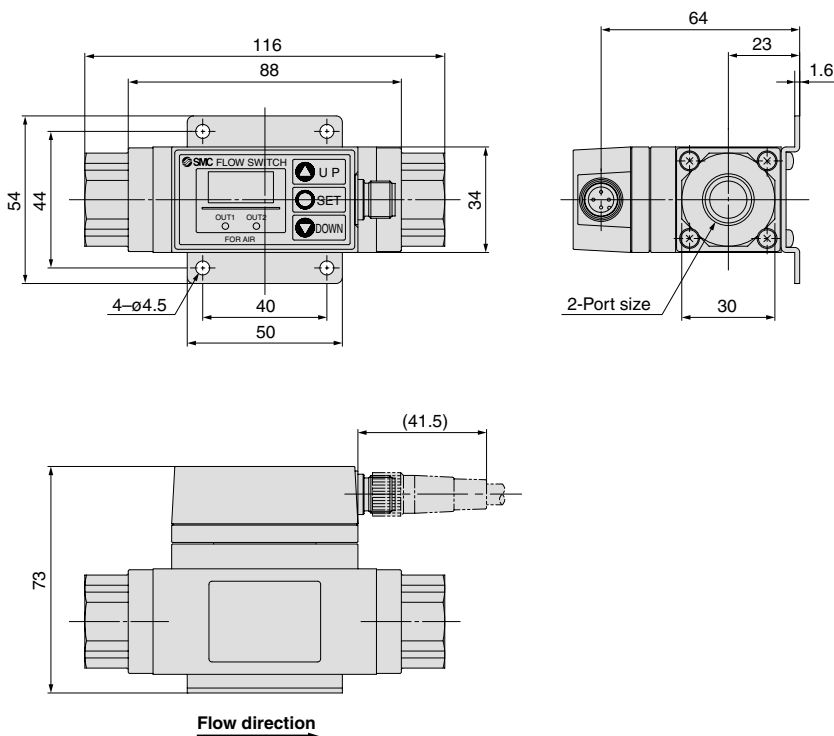

### Connector pin numbers

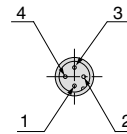

Pin no.	Pin description
1	DC (+)
2	OUT2
3	DC (-)
4	OUT1



## Functions: PF2A, PF2W

Refer to the operation manual how to set and to operate.

### Flow rate measurement selection

Real-time flow rate and accumulated flow rate can be selected. Up to 999999 of flow rate value can be accumulated.

### Unit switching

For Air

Display	Real-time flow rate	Accumulated flow
U_1	l/min	l
U_2	CFM x 10 <sup>-2</sup> , CFM x 10 <sup>-1</sup>	ft <sup>3</sup> x 10 <sup>-1</sup>

CFM = ft<sup>3</sup>/min

### High Flow Rate Type (For Air)

Display	Real-time flow rate	Accumulated flow
U_1	l/min	l, m <sup>3</sup> , m <sup>3</sup> x 10 <sup>3</sup>
U_2	CFM	ft <sup>3</sup> , ft <sup>3</sup> x 10 <sup>3</sup> , ft <sup>3</sup> x 10 <sup>6</sup>

### High Temperature Fluid Type (For Water)

Display	Real-time flow rate	Accumulated flow
U_1	l/min	l
U_2	GPM	gal (US)

GPM = gal (US)/min

Note) Fixed SI unit [l/min or l] will be set for the type without the unit switching function.

### Flow rate conversion

Basic state: 0°C, 101.3 kPa

Standard state: 20°C, 101.3 kPa, 65%RH (ANR)

Switchable between these states.

### Flow rate measuring unit confirmation

This function allows to confirm the accumulated flow rate when real-time flow rate is selected and to confirm the real-time flow rate when accumulated flow rate is selected.

### Error correction

LED display	Contents	Solution
Er1 <small>Note 1)</small>	A current of more than 80mA is flowing to OUT1.	Check the load and wiring for OUT1.
Err_1 <small>Note 2)</small>		
Er2 <small>Note 1)</small>	A current of more than 80mA is flowing to OUT2.	Check the load and wiring for OUT2.
Err_3 <small>Note 2)</small>	The setting data has changed for whatever reasons.	Perform the RESET operation, and reset all data again.
Er4 <small>Note 1)</small>		
--- <small>Note 1)</small>	The flow rate is over the flow rate measurement range (for air only).	Reduce the flow rate until it is within the flow rate measurement range, using an adjustment valve.
----- <small>Note 2)</small>		

Note 1) Applicable for all integrated display types other than series PF2A7□□H and remote type sensor display units.

Note 2) Only for series PF2A7□□H.

### Key lock

This function prevents incorrect operations such as changing the set value accidentally.

### Accumulation clearance

This is to clear the accumulated value.

### Initialization of setting (Only for series PF2A7□□H)

This is to restore the setting to the initial state when dispatched from the factory.

### Output types

Real-time switch output, accumulated switch output, or accumulated pulse output can be selected as an output type.

#### Real-time switch output (OUT1, OUT2)

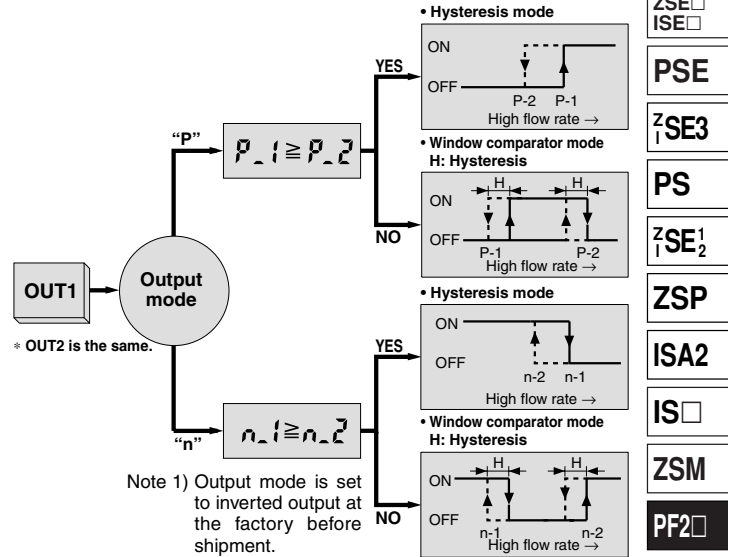

- ZSE□
- ISE□
- PSE
- ZSE3
- PS
- ZSE<sub>1</sub>
- ZSE<sub>2</sub>
- ZSP
- ISA2
- IS□
- ZSM
- PF2□
- IF□
- Data

#### Accumulated switch output (OUT1, OUT2)

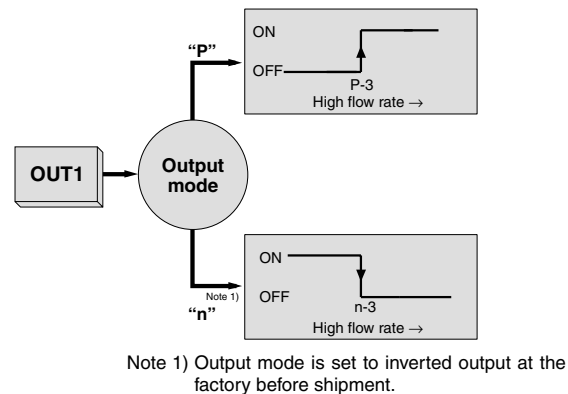

#### Accumulated pulse output (OUT1, OUT2)

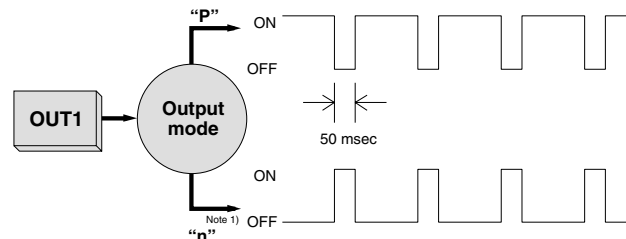

Note 1) For digital flow switch with unit switching function. (Fixed SI unit [l/min, or l, m<sup>3</sup> or m<sup>3</sup> x 10<sup>3</sup>] will be set for switch types without unit switching function.) Refer to the specifications of display unit for the flow rate value per pulse.



# Specific Product Precautions 1

Be sure to read before handling.

## Design and Selection

### Warning

- 1. Operate the switch only within the specified voltage.**

Use of the switch outside the range of the specified voltage can cause not only malfunction and damage of the switch but also electrocution and fire.

- 2. Do not exceed the maximum allowable load specification.**

A load exceeding the maximum load specification can cause damage to the switch.

- 3. Do not use a load that generates surge voltage.**

Although surge protection is installed in the circuit at the output side of the switch, damage may still occur if a surge is applied repeatedly. When a surge generating a load such as a relay or solenoid is directly driven, use a type of switch with a built-in surge absorbing element.

- 4. Since the type of fluid varies depending on the product, be sure to verify the specifications.**

The switches do not have an explosion proof rating. To prevent a possible fire hazard, do not use with flammable gases or fluids.

- 5. Monitor the internal voltage drop of the switch.**

When operating below a specified voltage, it is possible that the load may be ineffective even though the pressure switch function is normal. Therefore, the formula below should be satisfied after confirming the minimum operating voltage of the load.

$$\text{Supply voltage} - \text{Internal voltage drop of switch} > \text{Minimum operating voltage of load}$$

[For air]

- 6. Use the switch within the specified flow rate measurement and operating pressure.**

Operating beyond the specified flow rate and operating pressure can damage the switch.

[For water]

- 7. Use the switch within the specified flow rate measurement and operating pressure.**

Operating beyond the specified flow rate and operating pressure can damage the switch. Avoid especially the application of pressure above specifications through a water hammer.

<Examples of pressure reduction measures>

- Use a device such as a water hammer relief valve to slow the valve's closing speed.
- Absorb impact pressure by using an accumulator or elastic piping material such as a rubber hose.
- Keep the piping length as short as possible.

- 8. Design the system so that the fluid always fills the detection passage.**

Especially for vertical mounting, introduce the fluid from the bottom to the top.

- 9. Operate at a flow rate within the flow rate measurement range.**

If operated outside of the flow rate measurement range, the Karman vortex will not be generated and normal measurement will not be possible.

## Design and Selection

[Series PF2A7□□H]

- 10. Sudden increase of flow rate may destroy the flow sensor. Ensure to open/close the flow control valve not to exceed the maximum flow rate measurement values.**

### Caution

- 1. Data of the flow switch will be stored even after the power is turned off.**

Input data will be stored in EEPROM so that the data will not be lost after the flow switch is turned off. (Data can be rewritten for up to one million times, and data will be stored for up to 20 years.)

## Mounting

### Warning

- 1. Mount switches using the proper tightening torque.**

When a switch is tightened beyond the specified tightening torque, the switch may be damaged. On the other hand, tightening below the specified tightening torque may cause the installation screws to come loose during operation.

Thread	Tightening torque N·m	Thread	Tightening torque N·m
Rc 1/8	7 to 9	Rc 3/4	28 to 30
Rc 1/4	12 to 14	Rc 1	36 to 38
Rc 3/8	22 to 24	Rc 1 1/2	48 to 50
Rc 1/2	28 to 30	Rc 2	48 to 50

- 2. Apply wrench only to the metal part of the pipings when installing the flow switch onto the system piping.**

Do not apply wrench to anything other than the piping attachment as this may damage the switch.

- 3. Monitor the flow direction of the fluid.**

Install and connect piping so that fluid flows in the direction of the arrow indicated on the body.

- 4. Remove dirt and dust from inside the piping using an air blower before connecting piping to the switch.**

- 5. Do not drop or bump.**

Do not drop, bump, or apply excessive impacts (490 m/s<sup>2</sup>) while handling. Although the external body of the switch (switch case) may not be damaged, the inside of the switch could be damaged and cause a malfunction.

- 6. Hold the body of the switch when handling.**

The tensile strength of the cord is 49N. Applying a greater pulling force on it can cause a malfunction. When handling, hold the body of the switch – do not dangle it from the cord.

- 7. Do not use until you can verify that equipment can operate properly.**

Following mounting, repair, or retrofit, verify correct mounting by conducting suitable function and leakage tests after piping and power connections have been made.

- 8. Avoid the mounting orientation with the bottom of the body facing up.**

The switch can be mounted in any way such as vertically or horizontally, however, avoid the mounting orientation with the bracket on the bottom of the body facing upward.



# Specific Product Precautions 2

Be sure to read before handling.

## Mounting

### Warning

[For air]

- 9. **Never mount a switch in a place that will be used as a scaffold during piping.**  
Damage may occur if an excessive load is applied to the switch.
- 10. **Be sure to allow straight pipe length that is minimum 8 times the port size upstream and downstream of the switch piping.**

When abruptly reducing the size of piping or when there is a restriction such as a valve on the upstream side, the pressure distribution in the piping changes and makes accurate measurement impossible. Therefore, flow restriction measures such as these should be implemented on the downstream side of the switch.

[For water]

- 11. **Never mount a switch in a place that will be used as a scaffold during piping.**  
Damage may occur if an excessive load is applied to the switch. Especially when the switch supports the piping, do not apply a load of 15 N·m or more to the metal part of the switch.
- 12. **Be sure to allow straight pipe length that is minimum 8 times the port size upstream and downstream of the switch piping.**

When abruptly reducing the size of piping or when there is a restriction such as a valve on the upstream side, the pressure distribution in the piping changes and makes accurate measurement impossible. Therefore, flow restriction measures such as these should be implemented on the downstream side of the switch.

When used with the downstream side open, be careful of the cavitation that is prone to occur.

## Wiring

### Warning

- 1. **Verify the color and terminal number when wiring.**  
Incorrect wiring can cause the switch to be damaged and malfunction. Verify the color and the terminal number in the instruction manual when wiring.
- 2. **Avoid repeatedly bending or stretching the lead wire.**  
Repeatedly applying bending stress or stretching force to the lead wire will cause it to break.
- 3. **Confirm proper insulation of wiring.**  
Make sure that there is no faulty wiring insulation (contact with other circuits, ground fault, improper insulation between terminals, etc.). Damage may occur due to excess current flow into a switch.
- 4. **Do not wire in conjunction with power lines or high voltage lines.**  
Wire separately from power lines and high voltage lines, avoiding wiring in the same conduit with these lines. Control circuits including switches may malfunction due to noise from these other lines.
- 5. **Do not allow loads to short circuit.**  
Although switches indicate excess current error if loads are short circuited, all incorrect wiring connections cannot be protected. Take precautions to avoid incorrect wiring.

## Usage

### Warning

- 1. **When using a switch for high temperature fluid, the switch itself also becomes hot due to the high temperature fluid. Avoid touching the switch directly as this may cause a burn.**

## Operating Environment

### Warning

- 1. **Never use in the presence of explosive gases.**  
The switches do not have an explosion proof rating. Never use in the presence of an explosive gas as this may cause a serious explosion.
- 2. **Mount switches in locations where there is no vibration greater than 98 m/s<sup>2</sup>, or impact greater than 490 m/s<sup>2</sup>.**
- 3. **Do not use in an area where surges are generated.**  
When there are units that generate a large amount of surge in the area around pressure switches, (e.g., solenoid type lifters, high frequency induction furnaces, motors, etc.) this may cause deterioration or damage to the switches' internal circuitry. Avoid sources of surge generation and crossed lines.
- 4. **Switches are not equipped with surge protection against lightning.**  
Flow switches are CE compliant; however, they are not equipped with surge protection against lightning. Lightning surge protection measures should be applied directly to system components as necessary.
- 5. **Avoid using switches in an environment where the likelihood of splashing or spraying of liquids exists.**

Switches are dustproof and splashproof; however, avoid using in an environment where the likelihood of heavy splashing or spraying of liquids exists. Since the display unit of the remote type switches featured here is not dust or splash proof, the use in an environment where liquid splashing or spraying exists must be avoided.

[For air]

- 6. **Use the switch within the specified fluid and ambient temperature range.**  
Fluid and ambient temperatures are 0° to 50°C. Take measures to prevent freezing fluid when below 5°C, since this may cause damage to the switch and lead to a malfunction. The installation of an air dryer is recommended for eliminating condensate and moisture. Never use the switch in an environment where there are drastic temperature changes even when these temperatures are operated within the specified temperature range.

[For water]

- 7. **Use the switch within the specified fluid and ambient temperature range.**  
The fluid and ambient temperatures range for the switches is 0° to 50°C (and 0° to 90°C for high temperature fluid). Take measures to prevent freezing fluid when below 5°C, since this may cause damage to the switch and lead to a malfunction. Never use the switch in an environment where there are drastic temperature changes even when these temperatures fall within the specified temperature range.

ZSE□  
ISE□

PSE

ZSE3

PS

ZSE<sub>1</sub>  
ISE<sub>2</sub>

ZSP

ISA2

IS□

ZSM

PF2□

IF□

Data



Be sure to read before handling.

## Maintenance

### Warning

1. **Perform periodical inspections to ensure proper operation of the switch.**  
Unexpected malfunctions may cause possible danger.
2. **Take precautions when using the switch for an interlock circuit.**  
When a pressure switch is used for an interlock circuit, devise a multiple interlock system to prevent trouble or malfunctioning, verify the operation of the switch and interlock function on a regular basis.
3. **Do not disassemble or perform any conversion work on flow switches.**

## Measured Fluid

### Warning

1. **Check regulators and flow adjustment valves before introducing the fluid.**  
If pressure or flow rate beyond the specified range are applied to the switch, the sensor unit may be damaged.  
[For air]
2. **The fluids that the switch can measure accurately are nitrogen and dry air. However, only dry air can be measured with the high flow rate type.**  
Please note that accuracy cannot be guaranteed when other fluids are used.
3. **Never use flammable fluids.**  
The flow velocity sensor heats up to approximately 150°C.
4. **Install a filter or mist separator on the upstream side when there is a possibility of condensate and foreign matter being mixed in with the fluid.**  
The rectifying device built into the switch will be clogged up and accurate measurement will no longer be possible.  
[For water]
5. **The fluid that the switch can measure accurately is water.**  
Please note that accuracy cannot be guaranteed when other fluids are used.

## Measured Fluid

### Warning

6. **Never use flammable fluids.**
7. **Install a filter on the inlet side when there is a possibility of condensate and foreign matter being mixed in with the fluid.**  
If foreign matter adheres to the switch's vortex generator or vortex detector, accurate measurement will no longer be possible.

## Others

### Warning

1. **Since switch output remains OFF while a message is displayed after the power is turned on, start measurement after a value is displayed.**
2. **Perform settings after stopping control systems.**  
When the switch's initial setting and flow rate setting are performed, output maintains the condition prior to the settings. With the 100, 200, and 500  $\ell/\text{min}$  type switches for air, output turns OFF when the switch's initial setting and flow rate setting are preformed.
3. **Do not apply excessive rotational force to the display unit.**  
The integrated type display unit can rotate 360°. Rotation is controlled by the stopper; however, the stopper may be damaged if the display unit is turned with excessive force.  
[For air]
4. **Be certain to turn on the power when the flow rate is at zero.**  
Allow an interval of 10 minutes after turning on the power, as there are some changes in the display.
5. **Flow rate unit**  
Switch measures at mass flow rates without being influenced by temperature and pressure. The switches use  $\ell/\text{min}$  as the flow rate indicator unit, in which the volumetric flow is substituted for mass flow at 0°C and 101.3 kPa. The volumetric flow rate at 20°C, 101.3 kPa, and 65% RH (ANR) can be displayed with the high flow rate type switches for air.

### Detection principle of digital flow switch for air

A heated thermistor is installed in the passage, and fluid absorbs heat from the thermistor as it is introduced to the passage. The thermistor's resistance value increases as it loses heat. Since the resistance value increase ratio has a uniform relationship to the fluid velocity, the fluid velocity can be detected by measuring the resistance value. To further compensate the fluid and ambient temperature, the temperature sensor is also built into the switch to allow stable measurement within the operating temperature range.

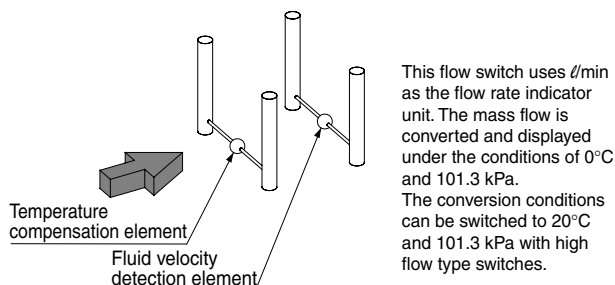

### Detection principle of digital flow switch for water

When an elongated object (vortex generator) is placed in the flow, reciprocal vortexes are generated on the downstream side. These vortexes are stable under certain conditions, and their frequency is proportional to the flow velocity, resulting in the following formula.

$$f = k \times v$$

f: Frequency of vortex v: Flow velocity k: Proportional constant (determined by the vortex generator's dimensions and shape).

Therefore, the flow rate can be measured by detecting this frequency.

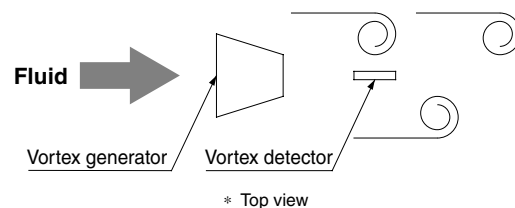



# Series PF2A/PF2W

## Specific Product Precautions 4

Be sure to read before handling.

### Set Flow Rate Range and Rated Flow Rate Range

#### Caution

Set the flow rate within the rated flow rate range.

The regulating flow rate range is the range of flow rate that can be set on the controller.

The rated flow rate range is the range of flow rate that satisfies the specifications (accuracy, linearity, etc.) of the sensor.

Although it is possible to set a value outside the rated flow rate range, the specifications will not be guaranteed even if the value stays within the regulating flow rate range.

#### <For Air: PF2A>

Sensor	Flow rate range							
	1 ℓ/min	5 ℓ/min	10 ℓ/min	20 ℓ/min	50 ℓ/min	100 ℓ/min	200 ℓ/min	500 ℓ/min
PF2A510	1 ℓ/min — 10 ℓ/min		0.5 ℓ/min — 10.5 ℓ/min					
PF2A550	5 ℓ/min — 50 ℓ/min		2.5 ℓ/min — 52.5 ℓ/min					
PF2A511	10 ℓ/min — 100 ℓ/min		5 ℓ/min — 105 ℓ/min					
PF2A521	20 ℓ/min — 200 ℓ/min		10 ℓ/min — 210 ℓ/min					
PF2A551	50 ℓ/min — 500 ℓ/min		25 ℓ/min — 525 ℓ/min					

#### <For Water: PF2W>

Sensor	Flow rate range							
	0.5 ℓ/min	2 ℓ/min	5 ℓ/min	10 ℓ/min	20 ℓ/min	40 ℓ/min	100 ℓ/min	
PF2W504 PF2W504T	0.5 ℓ/min — 4 ℓ/min		0.35 ℓ/min — 4.5 ℓ/min					
PF2W520 PF2W520T	2 ℓ/min — 16 ℓ/min		1.7 ℓ/min — 17 ℓ/min					
PF2W540 PF2W540T	5 ℓ/min — 40 ℓ/min		3.5 ℓ/min — 45 ℓ/min					
PF2W511	10 ℓ/min — 100 ℓ/min		7 ℓ/min — 110 ℓ/min					

Rated flow rate range of sensor  
 Set flow rate range of sensor

ZSE   
ISE

PSE

ZSE3

PS

ZSE1   
SE2

ZSP

ISA2

IS

ZSM

PF2

IF

Data