

AEDA-3300 Series

Ultra Miniature, High Resolution Incremental Kit Encoders



Data Sheet



Description

The AEDA-3300 series are high performance, cost effective, three-channel optical incremental encoder modules with integrated bearing stage. By using transmissive encoder technology to sense rotary position, the AEDA-3300 series emphasizes high reliability, high resolution and easy assembly. Outputs of the AEDA-3300 encoders are two channel quadrature and a third channel gated index signals. These encoders can be easily mounted to customer specific applications. Wide resolution options are available for the AEDA-3300 series, while keeping the same package size across the whole CPR range. The “One size fits all” package eliminates the need for customers to design different platforms for different resolutions. As the AEDA-3300 encoders are designed for high temperature and high operating frequency range, they are well suited for industrial automation and motion control applications.

Note: Avago Technologies encoders are not recommended for use in safety critical applications. E.g. ABS braking systems, power steering, life support systems and critical care medical equipment. Please contact sales representative if more clarification is needed.

Features

- Three channels output (quadrature A & B output with index channel)
- Resolution options from 600 to 20000 Cycles Per Revolution (CPR), up to 80000 counts with 4X decoding
- Cost effective
- -40 °C to 125 °C operating temperature
- Ultra miniature size (Ø17 mm)
- Maximum 1 MHz or 650 kHz operating frequency
- Maximum 12000 RPM rotational speed
- Single 5V supply
- Integrated RS 422 differential line driver
- Integrated bearing stage for easy mounting
- Bottom-up or top-down mounting options

Applications

- Motors
- Semiconductor Automation Machine
- Robotics
- Industrial Sewing Machine
- Packaging Machine
- Machine Tools
- Pick and Place Machines

ESD WARNING: NORMAL HANDLING PRECAUTIONS SHOULD BE TAKEN TO AVOID STATIC DISCHARGE.

Package Dimensions. Bottom-up Version

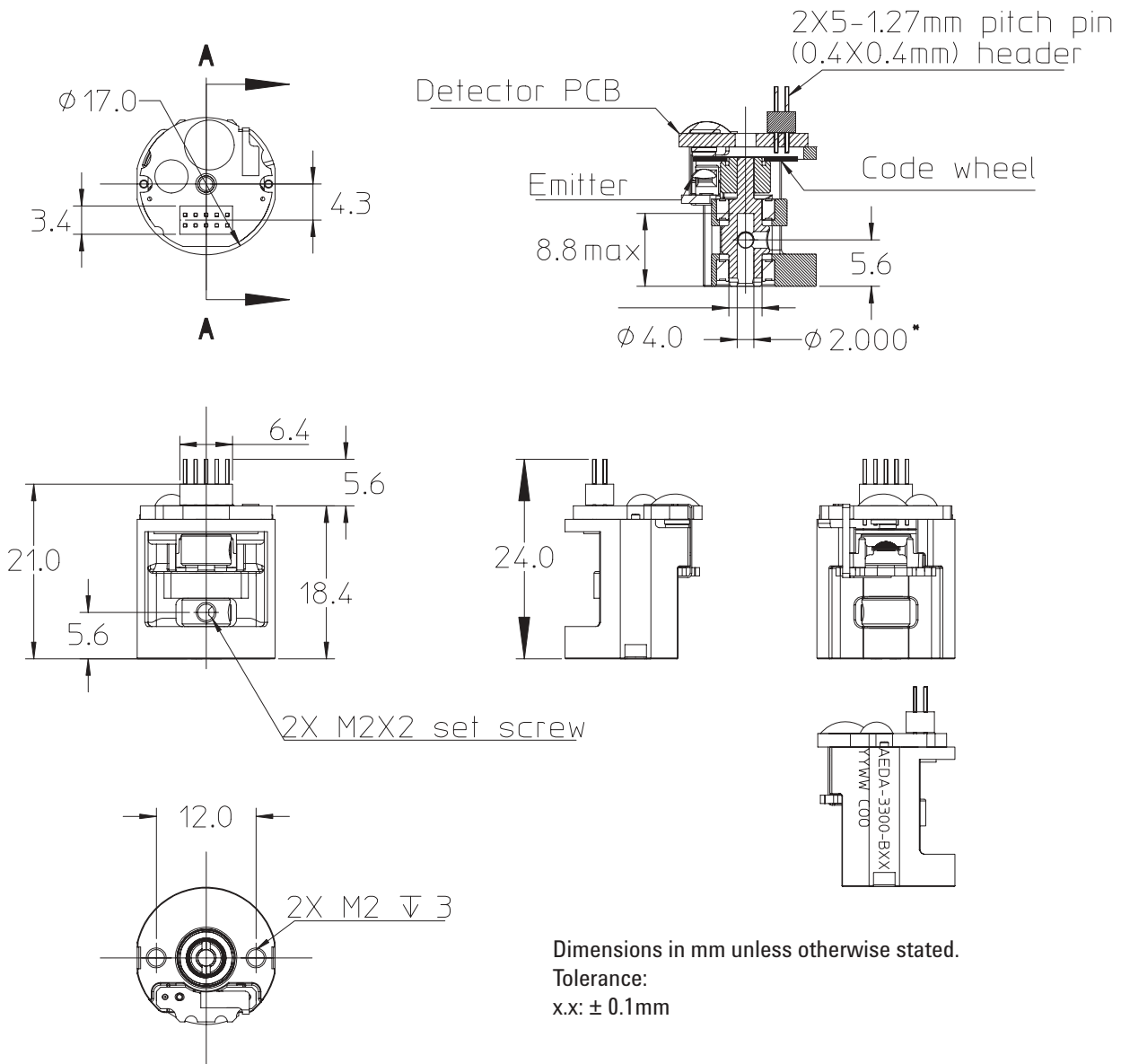

* Refer to Mechanical Characteristics Table for requirement on the solid shaft diameter.

Isometric Views. Bottom-up Version

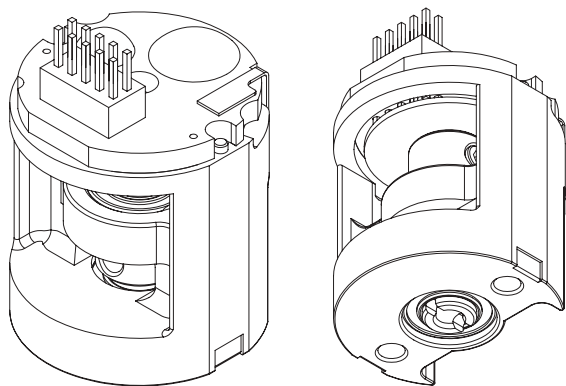

Package Dimensions. Top-Down Version (With Coupling Plate)

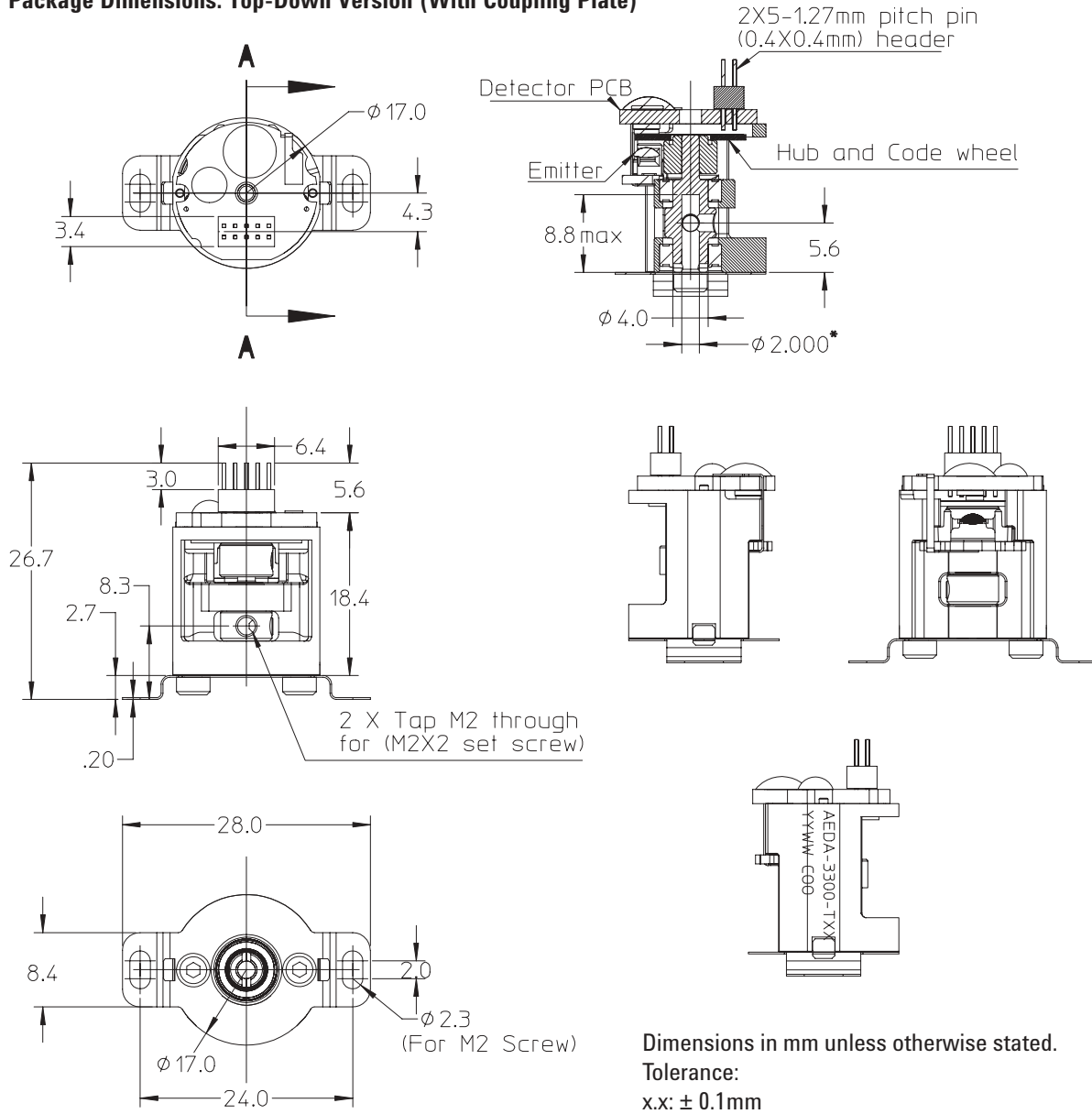

* Refer to Mechanical Characteristics Table for requirement on the solid shaft diameter.

Isometric Views. Top-Down Version (With Coupling Plate)

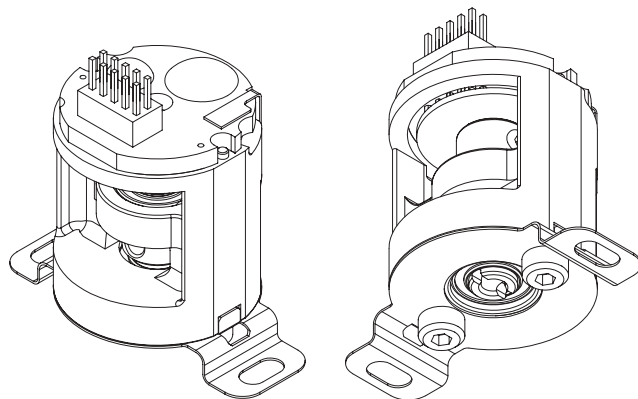

Absolute Maximum Ratings

Storage Temperature	-40 to 125 °C
Operating Temperature	-40 to 125 °C
Supply Voltage	4.5 V to 5.5 V
Output Voltage	-0.5 V to V _{CC}
Output Current per Channel	20 mA
Max Frequency	1 MHz

Note: Absolute Maximum Ratings are those values beyond which the safety of the device cannot be guaranteed. They are not meant to imply that the device should be operated at these limits. The tables "Recommended Operating Conditions and Characteristics" provide conditions for actual device operation.

Recommended Operating Conditions

Parameter	Symbol	Min.	Typical	Max.	Units	Notes
Temperature	T _A	-40	25	125	C	
Supply Voltage	V _{CC}	4.5	5	5.5	V	
Frequency	f			1.0	MHz	1. For CPR options of 10 000 CPR and below 2. Gated by maximum rotational speed of 12000 RPM. Refer to section
				650	kHz	3. Maximum Frequency and RPM. For CPR options above 10 000 CPR and up to 20 000 CPR 4. Please consult factory for special requirements of higher operating frequency

Encoding Characteristics

Encoding characteristics over recommended operating conditions. Typical values represent maximum values at 25°C and 2000 RPM (1000 RPM for options above 10 000 CPR). See Output Waveform for the definitions of the errors.

Parameter	Symbol	Typical	Max.	Units	Remarks
Pulse Width Error	ΔP	30	45	°e	See Note 1
		45	60		See Note 2
		55	70		See Note 3
State Width Error	ΔS	25	40	°e	See Note 1
		30	50		See Note 2
		50	60		See Note 3
Phase Error	$\Delta \phi$	20	20	°e	See Note 1
		25	30		See Note 2
		30	35		See Note 3
Index Pulse Width Error	ΔP_0	15	20	°e	See Note 1
		25	45		See Note 2
		40	45		See Note 3

Notes:

1. Applicable for CPR options of up to and include 4096 CPR
2. Applicable for CPR options from 5000 CPR, up to and include 10 000 CPR
3. Applicable for CPR options of above 10 000 CPR, and up to 20 000 CPR

Electrical Characteristics Table

Electrical characteristics over recommended operating conditions. Typical values at 25°C

Parameter	Symbol	Minimum	Typical	Maximum	Units	Notes
Supply Current	I _{CC}		55	100	mA	
High level Output Voltage	V _{OH}	2.5	3.4		V	
Low level Output Voltage	V _{OL}		0.3	0.5	V	

Mechanical Characteristics

Parameter	Dimension/Details	Tolerance	Units	Remarks
Standard Shaft Diameters	1.998	+0/-0.01 (+0/-0.0005)	mm (in)	
Mounting Screw Size: Bottom-up (threaded mount) Top-down (coupling plate)	M2 M2			
Weight	12		g	
Bearing material	Stainless Steel miniature precision bearing			
Maximum RPM	12000			See Note 1
Maximum Axial Load	8		N	Based on data provided by bearing manufacturer.
Maximum Radial Load	8		N	Based on data provided by bearing manufacturer.
Maximum Initial Torque	3 x 10 ⁻³		Nm	At 25 °C
Bearing Life	3		Years	Based on manufacturer's data. 24 hours continuous testing, at 125 °C and maximum RPM.

Note: 1. This value represents the maximum mechanical permissible shaft speed of the kit encoder. However, for options with CPR > 5000, the maximum shaft speed is limited by the maximum electrical frequency. Refer to Table Maximum Frequency and RPM for the comparison of the possible operable frequency and RPM.

Mechanical and Environmental Tests

Test Name	Reference	Conditions
Vibration (non-operating)	IEC 68-2-64	5-2000Hz at 20G for 6-axis
Shock (non-operating)	IEC68-2-27	100G at 10ms
ESD	IEC 61000-4-2	4kV
Electromagnetic Compatibility (EMC)	IEC61000-4-4	Spike Frequency = 5KHz, Duration = 15ms, Repetition = 300 ms, Test Points = ±1000 & ±1500V
Humidity	IEC-68-2-3	85 % RH (Non-condensing)

Note: Any mechanical shock and vibration exceeding the stated values may cause damage to the encoder. The encoder should not be subjected to excessive mechanical shock and vibration either during installation or operation.

Theory of Operation

The AEDA-3300 translates rotary motion of a shaft into three channels of digital output. The AEDA-3300 series consists of the following key parts: a single light emitting diode (LED) light source, a focusing lens, a high-precision codewheel, a photodetector IC with a set of uniquely configured photodiodes, an interpolator IC, and a line driver IC.

The LED emits light that is used to produce modulated by the codewheel to produce a set of analog signals. A high performance compensation and interpolation IC processes the analog signals to produce the digital A, B and index signals. These digital signals are further fed through a line driver IC that produces the final differential outputs for channels A, B, I, and their complements \bar{A} , \bar{B} and \bar{I} .

In a single size package, the AEDA-3300 is available for wide selection of cycles per revolution (CPR) options, from 600 to 20000. This translates to a maximum resolution of 80000 counts after quadrature decode (4X), satisfying the ever increasing requirement of higher encoder counts for better motion feedback performance.

Maximum Frequency and RPM

CPR	Maximum Frequency (kHz)	Maximum RPM
600	1000 ¹	12000
1000	1000 ¹	12000
1024	1000 ¹	12000
2000	1000 ¹	12000
2048	1000 ¹	12000
2500	1000 ¹	12000
3000	1000 ¹	12000
4000	1000 ¹	12000
4096	1000 ¹	12000
5000	1000	12000
6000	1000	10000
7200	1000	8300
7500	1000	8000
8000	1000	7500
8192	1000	7300
10000	1000	6000
10240	650	3800
12000	650	3250
14400	650	2700
18000	650	2150
20000	650	1950

Notes:

1. Maximum allowable operating frequency will be lower due to limitation in maximum permissible mechanical shaft speed.

The operable frequency is calculated based on the formula:

$$\text{Frequency (kHz)} = \text{CPR} \times (\text{RPM} / 60 \times 10^3)$$

As an example, for the 1000 CPR option, the operable frequency is up to 200 kHz, i.e.:

$$\text{Maximum operable frequency for 1000 CPR option} = 1000 \times (12000 / 60 \times 10^3) = 200 \text{ KHz}$$

Output Waveforms

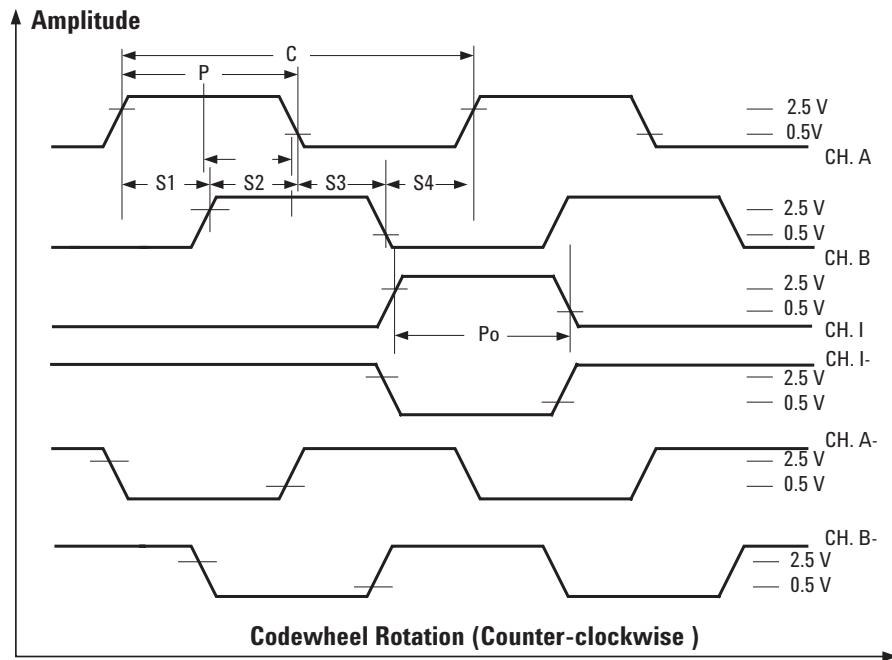

Definitions

Count (N): N refers to the cycles per revolution (CPR) of the encoder output.

One Cycle (C): 360 electrical degrees ($^{\circ}e$).

One Shaft Rotation: 360 mechanical degrees, N cycles (rotary motion only).

Phase (ϕ): The number of electrical degrees between the center of the high state on the channel A and the center of the high state of channel B. This value is nominally $90^{\circ}e$.

Pulse Width (P): The number of the electrical degrees that an output is a high-level during one cycle, nominally $180^{\circ}e$ or $1/2$ a cycle.

Pulse Width Error (ΔP): The deviation in electrical degrees of the pulse width from its ideal value of $180^{\circ}e$.

Index Pulse Width (P_0): The number of electrical degrees that an index is high during one full shaft rotation. This value is nominally $180^{\circ}e$ or $1/2$ cycle. $90^{\circ}e$ ($1/4$ cycle) index pulse width available upon request.

State Width (S): The number of the electrical degrees between transitions in the output of the channel B. There are 4 states per cycle, each nominally $90^{\circ}e$.

State Width Error (ΔS): The deviation in electrical degrees of each state width from its ideal value of $90^{\circ}e$.

Direction of Motor Rotation

When the codewheel rotates in a counter-clockwise direction, channel A will lead channel B (Figure 1 illustrates the definition of clockwise direction of codewheel rotation). When the codewheel rotates in a clockwise direction, channel B will lead channel A.

Clockwise direction of codewheel rotation.

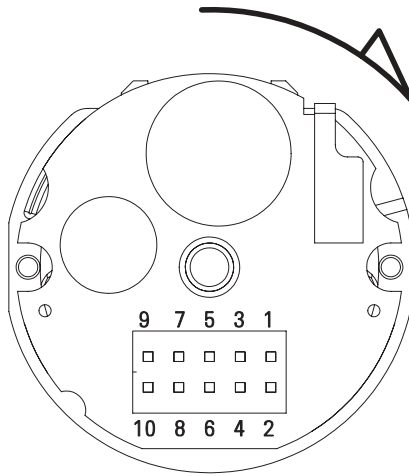

Figure 1. As viewed from the top PCB end of the encoder

Pin Assignments

Pin	Signal	Description
Pin 1	A+	Digital Output
Pin 2	A-	Digital Output
Pin 3	Gnd	Ground Pin
Pin 4	Gnd	Ground Pin
Pin 5	B+	Digital Output
Pin 6	B-	Digital Output
Pin 7	Vcc	Input Voltage
Pin 8	Vcc	Input Voltage
Pin 9	I+	Digital Output
Pin 10	I-	Digital Output

Note:

- Both Pin 7 and Pin 8 must be connected to Vcc.
- Either Pin 3 or Pin 4 must be connected to Gnd.

Electrical Interface

Avago Technologies recommends National Semiconductor DS26C32AM Quad Differential Line Receiver or compatible as line receiver. Unused pin should be grounded for noise reduction. Shielded Cable should be used for better noise immunity.

Mating Connector

AEDA-3300 requires a 5 x 2 (1.27 mm x 1.27 mm) female IDC Connector. The cable used is 0.635 mm pitch flat ribbon cable.

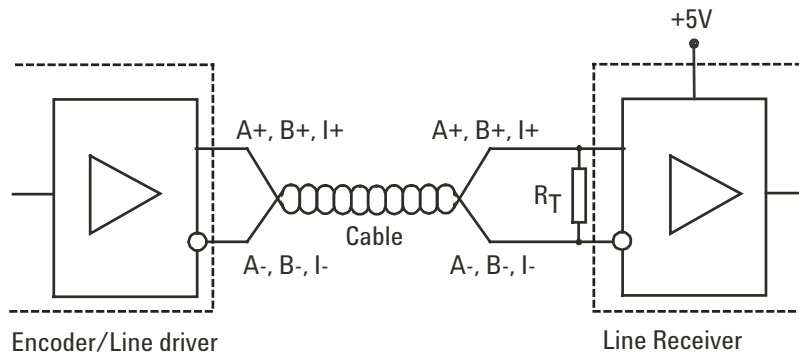

Figure 2. Recommended receiver circuit.

Ordering Information

AEDA - 3300 

Mounting Options	
T	Top-down, with coupling plate
B	Bottom-up, without coupling plate

Resolution Options		
	CPR	Counts after 4X Decoding
A4	600	2400
A6	1000	4000
A7	1024	4096
AB	2000	8000
AC	2048	8192
AJ	2500	10000
AM	3000	12000
AQ	4000	16000
AT	4096	16384
B 1	5000	20000
B 7	6000	24000
B J	7200	28800
B K	7500	30000
B M	8000	32000
B N	8192	32768
C 1	10000	40000
C 3	10240	40960
C H	12000	48000
C X	14400	57600
DM	18000	72000
E1	20000	80000

Note: Please contact the factory for availability of other CPR options.

For product information and a complete list of distributors, please go to our web site: www.avagotech.com

Avago, Avago Technologies, and the A logo are trademarks of Avago Technologies, Pte. in the United States and other countries.
Data subject to change. Copyright © 2006 Avago Technologies Pte. All rights reserved.

AV01-0084EN - March 30, 2006

