

## AEDS-96EX Series

Small Optical Encoder Modules 200 LPI Analog Voltage Output



## Data Sheet



### Description

The AEDS-96EX is a very small high performance, low cost optical incremental encoder module. When operated in conjunction with a codewheel/codestrip, this module detects rotary/linear position. The encoder module consists of a lensed Light Emitting Diode (LED) source and a detector IC enclosed in small C-Shaped plastic package. Due to highly collimated light source and a unique photodetector array, the module is extremely tolerant to mounting misalignment.

The two channel analog outputs and 3.3V supply input are accessed through four leads located on 2.00mm centers for the detector and two leads located on 2.54mm center for the emitter.

AEDS-96EX is designed for use with an appropriate optical radius codewheel. Please contact factory for more information.

### Features

- RoHS Compliant
- Small Size
- Low Cost
- Built-in guide bumps for codewheel and codestrip
- Low Package Height
- Insensitive to Radial, Tangential and Axial Play
- 0°C to +60°C recommended operating temperature
- Two Channel Analog Output
- Single 3.3V Supply
- Wave solderable

### Specifications

- 200 LPI
- 3.3V Supply\*
- 1.52V LED forward voltage (IF = 16mA)\*

\* Typical Conditions

### Applications

- Printers
- Copiers/Fax
- Plotters
- Office Automation Equipments

## Theory of Operation

The AEDS-96EX is a C-shaped emitter/detector module. Coupled with a codewheel/codestrip, it translates rotary motion into a two-channel analog output.

The module contains a single Light Emitting Diode (LED) as its light source. The light is collimated into a parallel beam by means of a single lens located directly over the LED. Opposite the emitter is the integrated detector circuit. This IC consists of multiple sets of photodiodes and the signal processing circuitry necessary to produce the analog waveforms.

The codewheel/codestrip moves between the emitter and detector, causing the light beam to be interrupted by the pattern of spaces and bars on the codewheel/codestrip.

The photodiodes, which detect these interruptions, are arranged in a pattern that corresponds to the radius and count density of the codewheel/codestrip.

These detectors are also spaced such that a light period on one pair of detectors corresponds to a dark period on the adjacent pairs of detectors. The photodiode outputs are fed through the signal processing circuitry, which produce the final outputs for Channel A and Channel B. Due to this integrated phasing technique, the analog output of Channel A is in quadrature with Channel B (90 degrees out of phase).

## Definitions

**Count (N):** The number of bar and window pairs or counts per revolution (CPR) of the codewheel. Or the number of lines per inch of the codestrip (LPI)

$$1 \text{ shaft Rotation} = 360 \text{ degrees} = N \text{ cycles}$$

$$1 \text{ cycle (c)} = 360 \text{ electrical degree, equivalent to 1 bar and window pair.}$$

**Direction of Rotation:** When the codewheel rotates in the counter-clockwise direction (as viewed from the encoder end of the motor), channel A will lead channel B. If the codewheel rotates in the clockwise direction, channel B will lead channel A.

**Line Density:** The number of window and bar pair per unit length, express in either lines per inch (LPI) or lines per mm (LPmm)

**Optical Radius (Rop):** The distance from the codewheel's center of rotation to the optical center (O.C) of the encoder module.

**Gap (G):** The distance from surface of the encoder to the surface of codewheel or codestrip

**Mounting Position (RM):** Distance from Motor Shaft center of rotation to center of Alignment Tab receiving hole.

**Radial and Tangential Misalignment Error (ER and Er):** For rotary motion mechanical displacement in the radial and tangential directions relative to the nominal alignment

**Angular Misalignment Error (EA):** Angular misalignment of the sensor in relation to then tangential direction. This applies for both rotary and linear motion.of electrical degrees that an output is high during one cycle, nominally 180°e or 1/2 a cycle.

## AEDS-96EX Series Block Diagram

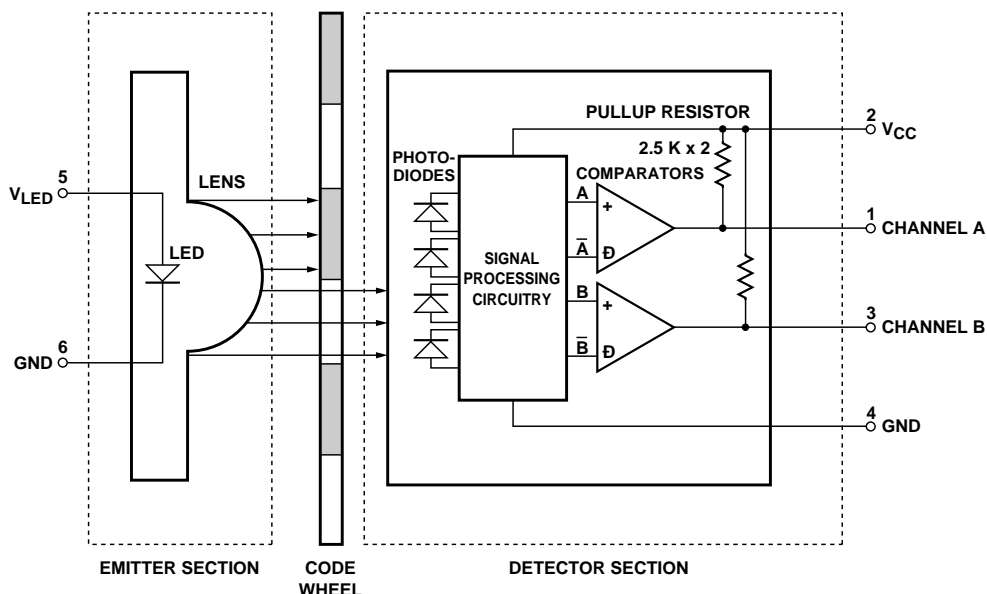

## Absolute Maximum Ratings

Subjecting the part to stresses beyond those listed under this section may cause permanent damage to the device. These are stress ratings only and do not imply that the device functions beyond these ratings. Exposure to the extremes of these conditions for extended periods may affect device reliability.

Parameter	Symbol	Min.	Max.	Units	Notes
Storage Temperature	$T_s$	-40	85	°C	
Operating Temperature	$T_A$	0	70	°C	
Supply voltage (Detector)	$V_{CC}$	-0.5	7	V	
Output Voltage	$V_a, V_b$	-0.5	$V_{CC} + 0.4$	V	
Soldering Temperature			260	°C	$t \leq 7$ sec
DC Forward current (LED)	$I_{LED}$		50	mA	$V_F < 1.8V$
Reverse Voltage	$V_R$		5	V	$I_R = 100\mu A$

## Recommended Operating Conditions

Parameter	Symbol	Min.	Typ.	Max.	Units	Notes
Operating Temperature	T	0	25	60	°C	
Supply Voltage (Detector)	$V_{CC}$	3.15	3.3	3.45	V	Ripple < 100mVpp
Output Frequency	f		8	50	KHz	(Velocity (rpm) x N)/60
DC Forward Current (LED)	$I_{LED}$	10	16	20	mA	Recommended 110Ω (±10%) series drop resistor between 3.3V supply and VLED.

## Electrical Characteristics

Electrical Characteristics over Recommended Operating Range, typically at 25°C

Parameter	Symbol	Min.	Typical	Max.	Units	Notes
Supply Current (Detector)	$I_{CC}$		5	8	mA	
LED Forward Voltage	$V_F$	1.3 (turn on) 1.5 (operate)	1.52	1.54	V	Typical $I_f = 16mA$

## Encoding Characteristics

The encoding characteristics stated below are obtained using parallel loading of 100pF capacitor and 100KW resistor

Parameter	Symbol	Mean (a)	Min (b)	Max (b)	Units
State width error	$\Delta S$	6.817		35	$^{\circ}e$
Pulse width error	$\Delta P$	5.421		35	$^{\circ}e$
State X width error	$\Delta S_x$	3.033		25	$^{\circ}e$
Pulse X width error	$\Delta P_x$	3.370		25	$^{\circ}e$
Upper crosspoint voltage	$V_{x12}, V_{x34}$	2.39	1.40	2.60	V
Lower crosspoint voltage	$V_{x56}, V_{x78}$	1.02	0.80	2.30	V
Peak to Peak voltage	$V_{ppA}$ $V_{ppB}$	2.13	1.00	3.00	V
Analog offset voltage	Voffset A, Voffset B	-14.52	-150	150	mV
*Average Linearity Error	$\Delta$ Linearity	3.93		9.25	%

Notes:

- \* Average linearity is the characterized parameter, 2 lines per cycle for each channel for full rotation of the codewheel.
- a. Obtained at typical conditions specified in "Recommended Operating Conditions" and nominal mounting position (Radial, Tangential, Gap) of (0, 0, 0)
- b. Obtained over the whole "Recommended Operating Conditions" and "Part Mounting Tolerances"

## Derating Characteristics

Derating Table of  $V_{pp}$  and Voffset at 3.15, 3.3 and 3.45 Volts (average of 30 units)

AC Parameter	@3.15 V	@3.3V	@3.45V
$V_{ppA}$ (V)	2.100	2.170	2.246
$V_{ppB}$ (V)	2.170	2.179	2.252
Voffset A (mV)	-40.89	-7.41	24.62
Voffset B (mV)	-44.33	-10.95	21.55

Note: Obtained at typical conditions specified in "Recommended Operating Conditions" and nominal mounting position (Radial, Tangential, Gap) of (0, 0, 0).

## Waveform Definition

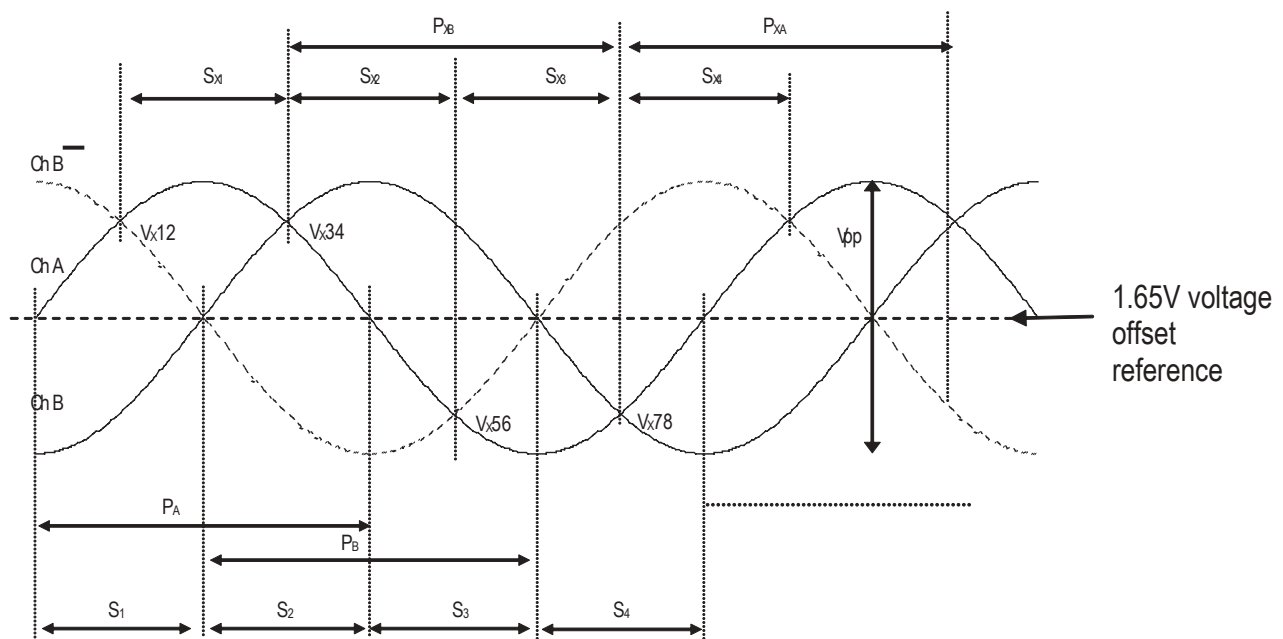

## Test Parameter Definitions

Parameter	Symbol	Definition	Units
Analog peak Voltage	Vap, Vbp, Vam, Vbm	The absolute value in V of the magnitude of the analog signal (i.e. one sided rating) sitting 1.65V voltage offset reference	V
Analog peak to peak Voltage	VppA VppB	The peak to peak signal magnitude in V of the analog signal	V
Analog peak to peak ratio	VppA/VppB	The ratio of A channel peak analog signal to B channel peak analog signal	-
Analog Crossing	Vx12, Vx34, Vx56, Vx78	The intersection in v of the A channel analog waveform with either the B channel analog waveform or its compliment.	V
Analog Offset Voltage	Voffset A Voffset B	The offset in V from the mid-point of the analog peak to peak signal to 1.65V voltage offset reference	mV
State Width	S1, S2, S3, S4	The number of electrical degrees between a transition in channel A and the neighboring transition in channel B. There are 4 state per cycle, each nominally 900°e. The transitions are determined by where the analog signal crosses the Zero point	°e
State Width Error	ΔS1, ΔS2, ΔS3, ΔS4	The deviation in electrical degrees of each state width from its ideal value of 900°e.	°e
Pulse Width	PA,PB	The number of electrical degrees that an analog output is greater than zero during on°e cycle. This value is nominally 1800°e or ½ cycle.	°e
Pulse Width Error	P	The deviation in electrical degrees of each pulse width from its ideal value of 1800°e.	°e
State X Width	S <sub>x1</sub> S <sub>x2</sub> S <sub>x3</sub> S <sub>x4</sub>	The number of electrical degree between a transition in channel A and the neighboring transition in channel B. There are 4 state per cycle, each nominally 900°e. The transitions are determined by where the A analog signal and B analog signal (or its complement) cross.	°e
State X Width Error	ΔS <sub>x1</sub> , ΔS <sub>x2</sub> ΔS <sub>x3</sub> , ΔS <sub>x4</sub>	The deviation in electrical degrees of each state x width from its nominal value of 900°e.	°e
Pulse X Width	P <sub>xA</sub> P <sub>xB</sub>	Pulse X width A is the number of electrical degrees that analog A output is greater than analog B bar output during one cycle. Pulse X width B is the number of electrical degrees that analog B is greater than analog A during one cycle. This value is nominally 1800°e or ½ cycle.	°e
Pulse X Width Error	P <sub>xA</sub> , P <sub>xB</sub>	The deviation in electrical degrees of each pulse x width from its nominal value of 1800°e.	°e
Max Linearity Error	Linearity	Ratio (in percentage) of maximum voltage deviation from a straight line connecting adjacent upper and lower crosspoint voltages to the difference between crosspoint voltages	%

## Mounting Configuration

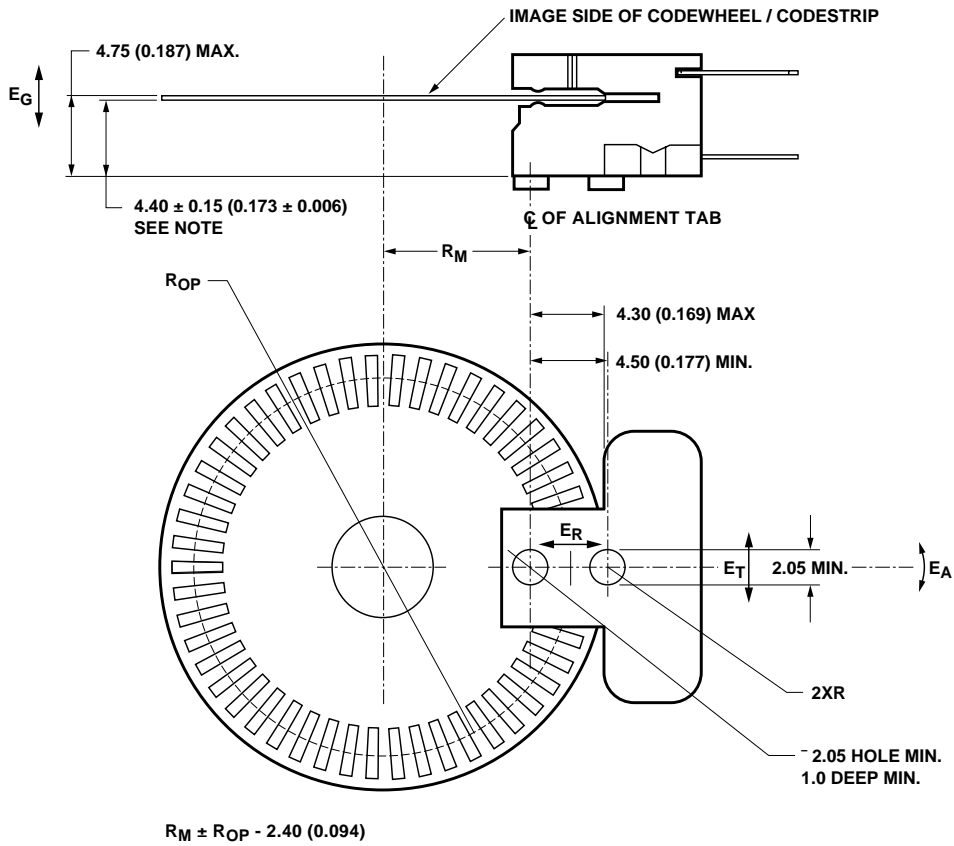

Error		Rop=11.00mm	Unit	Notes
Eg	Gap	± 0.15	mm	Recommend CW to put closer to the detector side (upper side), in order to give enough margin for encoder operation.
Er	Radial	± 0.13	mm	
Et	Tangential	± 0.13	mm	
Ea	Angular	± 3	Deg.	

### Note:

These dimension includes shaft end play and codewheel warp. All dimensions for mounting in the module and codewheel/codestrip should be measured with respect to the two mounting post shown above.

# Package Dimension

## AEDS-96E0-R10

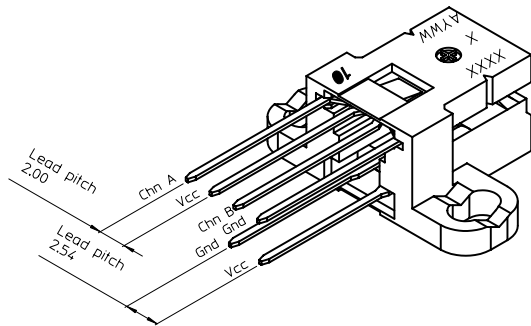
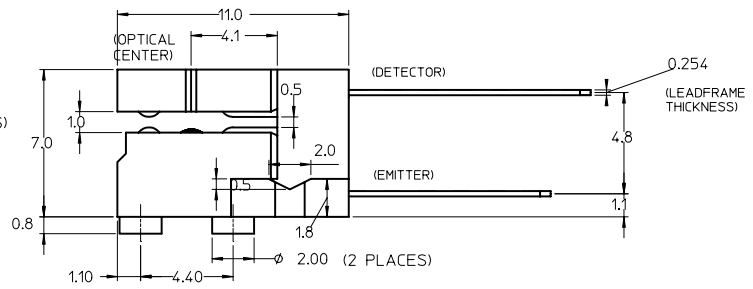
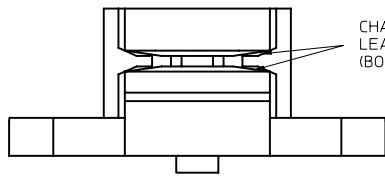
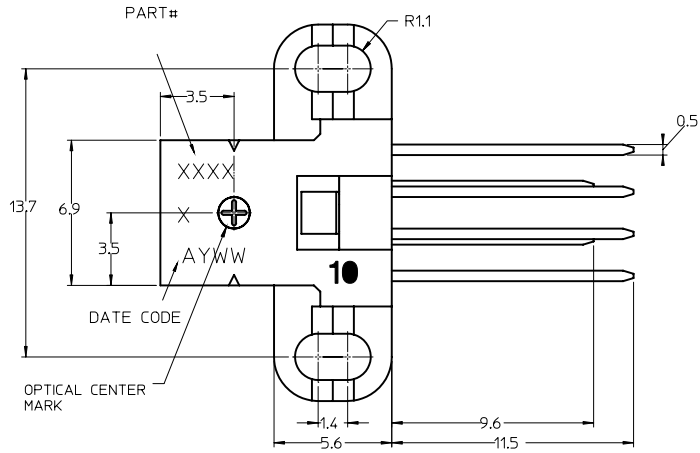
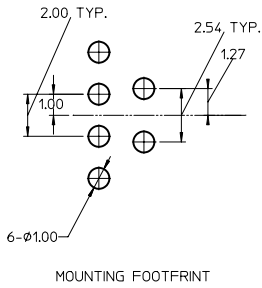

**AEDS-96E1-R10**

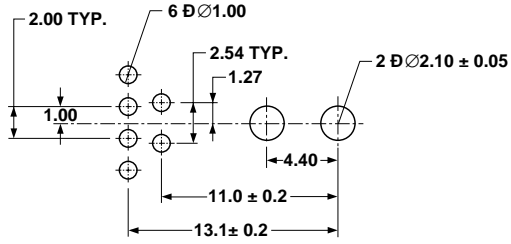
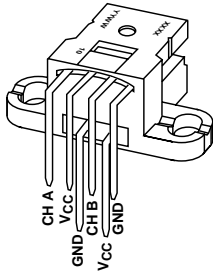

**MOUNTING FOOTPRINT**

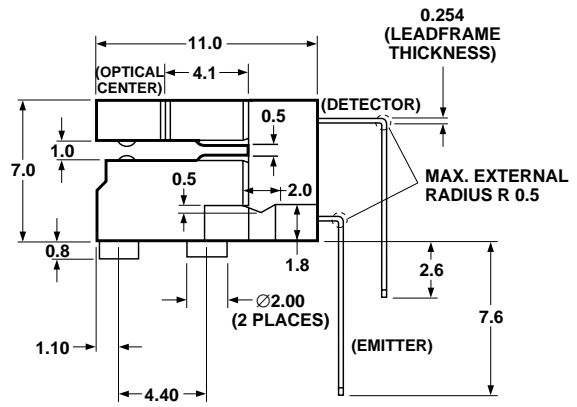
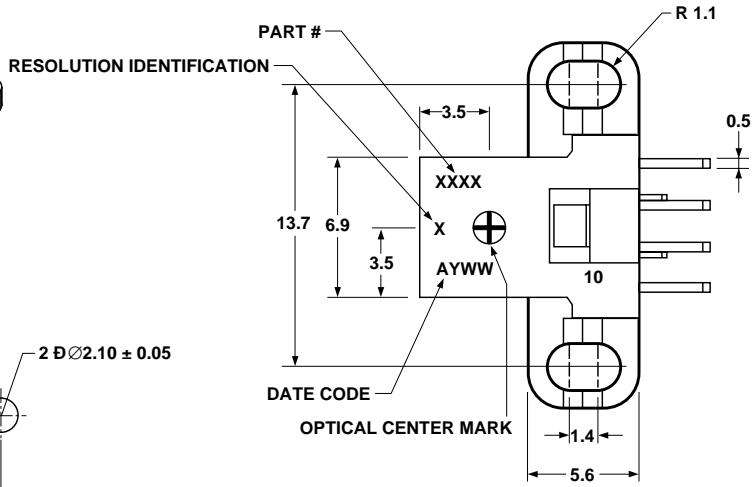
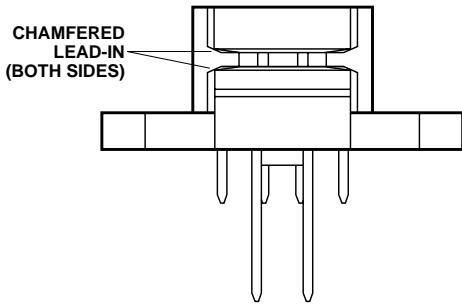



## Recommended Wave Solder Profile

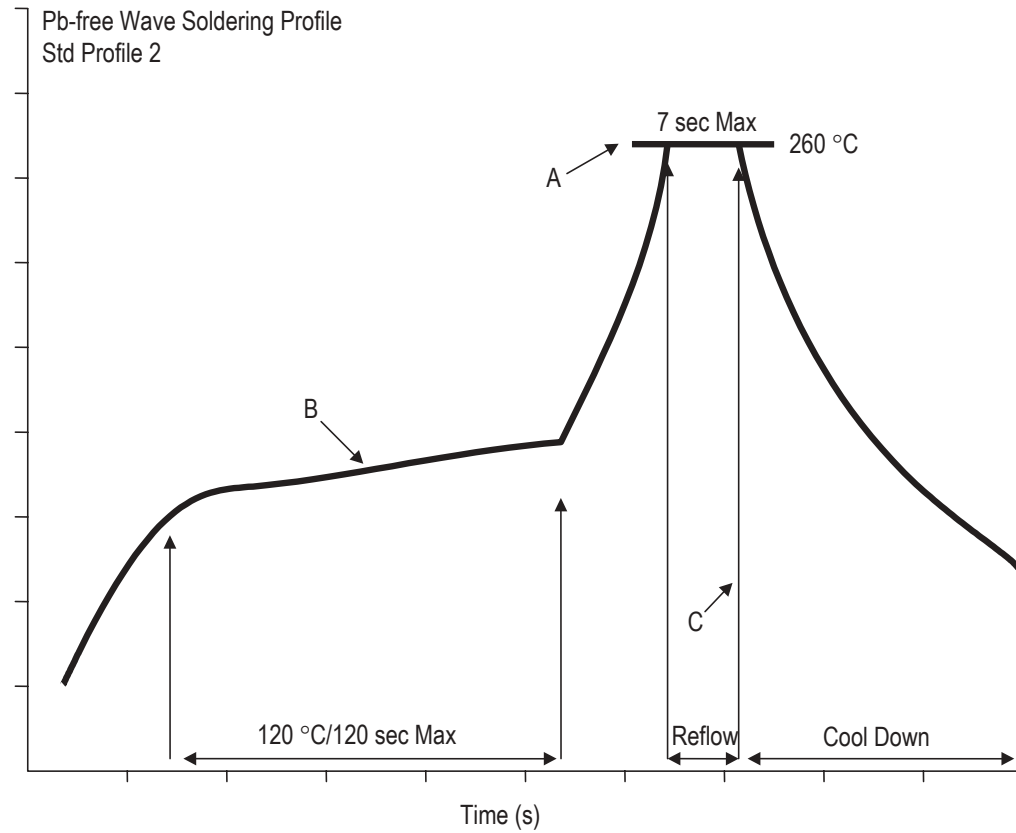

	Parameter	Min.	Max.	Nominal values	Units
A	Solder Pot Temperature	NA	260	250 - 260	° C
B	Preheat Zone Temperature	85	120	100 - 120	° C
C	Dip in Time	5	7	5	sec
D	Solder Pot Zone (Encoder Lead)	200	260	NA	° C

Note:

- Nominal values are evaluated profiles for optimum performance.
- Min/Max are critical limits to ensure encoders in good condition.

For product information and a complete list of distributors, please go to our web site: **[www.avagotech.com](http://www.avagotech.com)**

Avago, Avago Technologies, and the A logo are trademarks of Avago Technologies, Limited in the United States and other countries.  
Data subject to change. Copyright © 2006 Avago Technologies Pte. All rights reserved.  
AV01-0107EN - April 19, 2006

