

EAO – Your Expert Partner for
Human Machine Interfaces



EAO Product Information

Series 70

e a o ■



Description 3

Product Assembly 4

PCB Pushbuttons 5

Accessories..... 7

Technical Data..... 9

Application guidelines..... 11

Drawings..... 12

Index..... 17

Product Information

General notes

Series 70 offers users an all-bright momentary switch for use in membrane switching systems. Now for the first time the single LED permits exceedingly bright illumination of the complete touch surface in 6 colours in either a round or square configuration.

When employed together with the optionally available white caps the ON condition of these products is clearly visible even under conditions of high ambient lighting due to the change in colour from white to the corresponding LED colour.

Where more importance is attached to the brilliance than the wavelength (color) of the green light the yellow multi LED can be combined with the green cap to boost the light output of the naturally weaker green version. Switchless indicators, non-illuminated types as well as blank elements round of this assortment.

PCB layout and style are in keeping with the most popular switch elements employed in film-seal keypads. Merly the LED leads need to be supplemented in the existing layout. Due to the neat styling and sculptured surface of the caps all products can also be put to use as normal PCB switches having no film seal.

This permits huge savings in the cost of small quantities or pilot series and when keypad seal requirement are not critical. Customized and collated deliveries are possible on request for large-quantity orders.

Specimen order

PCB Pushbutton :

- Switching element illuminative 92-851.342

Essential accessories :

- Lens 15.4 x 15.4 mm, yellow 70-921.4

- Single-LED T1 Bi-Pin, 2.2 VDC, 20 mA, yellow 10-2602.3174D

*We reserve the right to modify technical data
All dimensions in mm*

Illuminated pushbutton



- 1 Lens
- 2 Switching element

Illumination element

The customer has to decide what series resistor shall be used to the LED



Essential Accessories:

Lens page 7

	Illumination	Operating voltage/-current	Terminals	Typ-Nr.	Component layout	Technical drawing	Circuit drawing	
Illumination element	-	-	P	92-800.042	3	10		0.001
	Bi-colour-LED red/green	1.9/3.5 VDC, 20 mA	P	70-820.25	3		1	0.001
	Bi-colour-LED yellow/green	2.0/3.2 VDC, 20 mA	P	70-820.45	3		1	0.001
	Single-LED blue	3.5 VDC, 20 mA	P	70-820.6	3		3	0.001
	Single-LED green	3.5 VDC, 20 mA	P	70-820.5	3		3	0.001
	Single-LED orange	2.1 VDC, 20 mA	P	70-820.3	3		3	0.001
	Single-LED red	2.1 VDC, 20 mA	P	70-820.2	3		3	0.001
	Single-LED white	3.5 VDC, 20 mA	P	70-820.9	3		3	0.001
	Single-LED yellow	2.2 VDC, 20 mA	P	70-820.4	3		3	0.001

Terminals: P = PCB terminal

Component layout from page 12, Technical drawing from page 13, Circuit drawing from page 15

Switching element non-illuminated



Essential Accessories:

Spacing cap page 7

	Switching action	Contacts	Contact material	Terminals	Typ-Nr.	Component layout	Technical drawing	Circuit drawing	
Switching element non-illuminated with spacing cap	M	1 NO	Au	P	70-201.0	2	9	4	0.001
			Ag	P	70-101.0	1	8	6	0.001
without spacing cap	M	1 NO	Ag	P	70-100.0	1	7	6	0.001

Switching action: M = Momentary action

Contacts: NO = Normally open

Contact material: Au = Gold, Ag = Silver

Terminals: P = PCB terminal

Component layout from page 12, Technical drawing from page 13, Circuit drawing from page 15

Switching element illuminative

The customer has to decide what series resistor shall be used to the LED



Essential Accessories:

Lens page 7

	Switching action	Contacts	Illumination	Operating voltage/-current	Terminals	Typ-Nr.	Component layout	Technical drawing	Circuit drawing	
Switching element illuminative	M	1 NO	-	-	P	92-851.342	4	11	4	0.001
			Bi-colour-LED red/green	1.9/3.5 VDC, 20 mA	P	70-220.25	4		2	0.001
			Bi-colour-LED yellow/green	2.0/3.2 VDC, 20 mA	P	70-220.45	4		2	0.001
			Single-LED blue	3.5 VDC, 20 mA	P	70-220.6	4		5	0.001
			Single-LED green	3.5 VDC, 20 mA	P	70-220.5	4		5	0.001
			Single-LED orange	2.1 VDC, 20 mA	P	70-220.3	4		5	0.001
			Single-LED red	2.1 VDC, 20 mA	P	70-220.2	4		5	0.001
			Single-LED white	3.5 VDC, 20 mA	P	70-220.9	4		5	0.001
			Single-LED yellow	2.2 VDC, 20 mA	P	70-220.4	4		5	0.001

Switching action: M = Momentary action

Contacts: NO = Normally open

Terminals: P = PCB terminal

Component layout from page 12, Technical drawing from page 13, Circuit drawing from page 15

Front

Lens

Lens	Lens	∅ 19.05 x 19.05 mm	∅ 15.4 x 15.4 mm	∅ 12.4 x 12.4 mm	∅ 15.4 mm	∅ 12.4 mm	Technical drawing	kg
		Typ-Nr.	Typ-Nr.	Typ-Nr.	Typ-Nr.	Typ-Nr.		
Plastic translucent	white	70-920.9	70-921.9		70-911.9		5	0.001
	blue		70-921.6				5	0.001
	green		70-921.5		70-911.5		5	0.001
	orange		70-921.3		70-911.3		5	0.001
	red		70-921.2		70-911.2		5	0.001
	yellow		70-921.4		70-911.4		5	0.001
	blue			70-922.6			6	0.001
	green			70-922.5		70-912.5	6	0.001
	orange			70-922.3		70-912.3	6	0.001
	red			70-922.2		70-912.2	6	0.001
	white			70-922.9		70-912.9	6	0.001
	yellow			70-922.4		70-912.4	6	0.001



Technical drawing from page 13

Spacing cap

	Typ-Nr.	Technical drawing	kg
Spacing cap 2 recesses for LED, H 13 mm	70-911.0	2	0.001
2 recesses for LED, H 22.5 mm	70-912.0	3	0.001
2 recesses for LED, H 9 mm	70-910.0	1	0.001
without recesses for LED, H 18.9 mm	70-901.0	4	0.001



Technical drawing from page 13

Illumination

Single-LED

The customer has to decide what series resistor shall be used to the LED

Single-LED	Socket	Light colour	Operating voltage/-current	Typ-Nr.	kg
	T1 Bi-Pin	blue	3.5 VDC, 20 mA	10-2602.3206L	0.001
		green	3.5 VDC, 20 mA	10-2602.3205L	0.001
		orange	2.1 VDC, 20 mA	10-2602.3203L	0.001
		red	2.1 VDC, 20 mA	10-2602.3202L	0.001
		white	3.5 VDC, 20 mA	10-2602.3209L	0.001
		yellow	2.2 VDC, 20 mA	10-2602.3174D	0.001



Bi-colour LED

The customer has to decide what series resistor shall be used to the LED

	Socket	Light colour	Operating voltage/-current	Typ-Nr.	RoHS
Bi-colour LED	T1 Bi-Pin	red/green	1.9/3.5 VDC, 20 mA	10-2603.320AL	0.001
		yellow/green	2.0/3.2 VDC, 20 mA	10-2603.320CL	0.001



Multi-LED

The customer has to decide what series resistor shall be used to the LED

	Socket	Light colour	Operating voltage/-current	Typ-Nr.	RoHS
Multi-LED	T1 Bi-Pin	yellow	12 VDC, 40 mA	10-5609.3174D	0.001



Switching element illuminated

Switching system

Short-travel switching system with 2 independent contact points and tactile operation. Guarantees reliable switching even of very light loads.

1 normally open contact

Material

Material of contact

Gold (Au)

Switching element

Thermoplastic Polyester (PET, PBT) and Polyacetale (POM)

Mechanical characteristics

Actuating force

with overlay foil 4 N \pm 1,5 N

Max. actuating force >50 N, as per DIN 42115

Actuating travel

0.4 mm

Rebound time

\leq 1 ms

Resistance to heat of soldering

260 °C, 5 s, as per IEC 60068-2-20

Mechanical lifetime

>5 million operations

Electrical characteristics

Contact resistance

Starting value (initial) \leq 100 m Ω , as per IEC 60512-2-2b

Isolation resistance

\geq 1000 M Ω

Contact resistance

\leq 100 m Ω

as per 500 000 cycles of operation at 12 VDC, 5 mA resistive load \leq 200 m Ω

Electrical life

\geq 500 000 operations at 42 VDC, 50 mA, as per IEC 60512-5-9c

When attention is paid to the direction of current flow from terminal $\frac{3}{4}$ to $\frac{1}{2}$ the electrical life can be prolonged.

Switch rating

max. 2 VA (resistive load)

Switch rating

Switching voltage VDC/VAC min. 50 mV, max. 42 V

Switching current VDC/VAC min. 10 μ A, max. 100 mA

Power rating max. 2 W

Electric strength

500 VAC, 50 Hz, 1 min, as per IEC 60512-2-4a

Electrical characteristics LED

Constant current

15 ... 20 mA

Pre-voltage

Multi-LED typ. 12.5 V

Single-LED typ. 2.2 V

Environmental conditions

Storage temperature

-40 °C ... +85 °C

Operating temperature

-25 °C ... +70 °C

Front protection

front with overlay foil IP 65

Approvals

Declaration of conformity

RoHS

Switching element non-illuminated

Typ-Nr. 70-100.0 and 70-101.0

Switching system

Short-travel switching system with 2 independent contact points and tactile operation. Guarantees reliable switching even of very light loads.

1 normally open contact

Material

Material of contact

Silver (Ag)

Mechanical characteristics

Actuating force

with overlay foil 5 N \pm 2 N

Max. actuating force >50 N, as per DIN 42115

Actuating travel

0.3 mm

Rebound time

\leq 5ms

Mechanical lifetime

>1 million operations

Electrical characteristics

Isolation resistance

\geq 50 M Ω

Contact resistance

\leq 100 m Ω

as per 500 000 cycles of operation at 12 VDC, 5 mA resistive load \leq 200 m Ω

Electrical life

at 5 VDC, 1 mA >1 million operations

at 24 VDC, 1 mA >100 000 operations

Switch rating

\leq 1 VA (resistive load)

Switch rating

\leq 24 VDC, \leq 50 mA

Electric strength

250 VAC for 1 min.

Environmental conditions

Storage temperature

-30 °C ... +85 °C

Operating temperature

-20 °C ... +70 °C

Front protection

front with overlay foil IP 65

Switching element non-illuminated Typ-Nr. 70-201.0

Switching system

Short-travel switching system with 2 independent contact points and tactile operation. Guarantees reliable switching even of very light loads.

1 normally open contact

Material

Material of contact

Gold (Au)

Switching element

Thermoplastic Polyester (PET, PBT) and Polyacetale (POM)

Mechanical characteristics

Actuating force

with overlay foil 2.1 N ±0.2 N

Max. actuating force >50 N, as per DIN 42115

Actuating travel

max. 0.5 mm

Rebound time

≤1 ms

Resistance to heat of soldering

260 °C, 5 s, as per IEC 60068-2-20

Mechanical lifetime

>5 million operations

Front protection

front with overlay foil IP 65

Electrical characteristics

Contact resistance

Starting value (initial) ≤100 mΩ, as per IEC 60512-2-2b

Isolation resistance

≥1000 MΩ

Contact resistance

≤100 mΩ

as per 500 000 cycles of operation at 12 VDC, 5 mA resistive load

≤200 mΩ

Electrical life

≥500 000 operations at 42 VDC, 50 mA, as per IEC 60512-5-9c

When attention is paid to the direction of current flow from terminal $\frac{3}{4}$ to $\frac{1}{2}$ the electrical life can be prolonged.

Switch rating

max. 42 V, 50 mA

min. 50 mV, 10 μ

Switch rating

Switching voltage VDC/VAC min. 50 mV, max. 42 V

Switching current VDC/VAC min. 10 mA, max. 100 mA

Switch rating max. 2 W

Electric strength

500 VAC, 50 Hz, 1 min, as per IEC 60512-2-4a

Environmental conditions

Storage temperature

-40 °C ... +85 °C

Operating temperature

-25 °C ... +70 °C

Front protection

front with overlay foil IP 65

Suppressor circuits

When switching inductive loads such as relays, DC motors, and DC solenoids, it is always important to absorb surges (e.g. with a diode) to protect the contacts. When these inductive loads are switched off, a counter emf can severely damage switch contacts and greatly shorten lifetime.

Fig. 1 shows an inductive load with a free-wheeling diode connected in parallel. This free-wheeling diode provides a path for the inductor current to flow when the current is interrupted by the switch. Without this free-wheeling diode, the voltage across the coil will be limited only by dielectric breakdown voltages of the circuit or parasitic elements of the coil. This voltage can be kilovolts in amplitude even when nominal circuit voltages are low (e.g. 12 VDC) see Fig. 2.

The free-wheeling diode should be chosen so that the reverse breakdown voltage is greater than the voltage driving the inductive load. The DC blocking voltage (VR) of the free-wheeling diode can be found in the datasheet of a diode. The forward current should be equal or greater than the maximum current flowing through the load.

To get an efficient protection, the free-wheeling diode must be connected as close as possible to the inductive load!

Switching with inductive load
Fig. 1

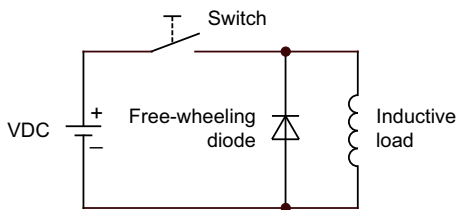

Counter emf
over load without free-wheeling diode
Fig. 2

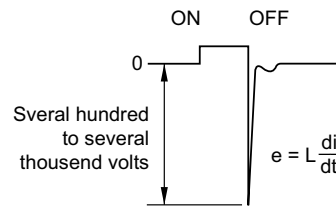

Component layout

1 Switching element non-illuminated page 5

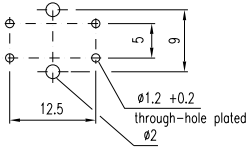

2 Switching element non-illuminated page 5

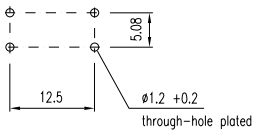

3 Illumination element page 5

Single-LED

Drilling plan (Elementside)

- B Holes for LED
- C Holes for centering pins

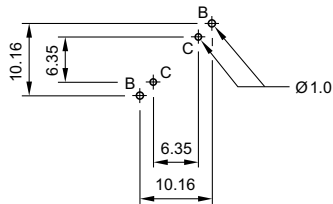

Bi-colour-LED

Drilling plan (Elementside)

- B Holes for Bi-colour LED:
BA1 (green) + BA2 (yellow or red) = Anodes, BC = Cathode
- C Holes for centering pins

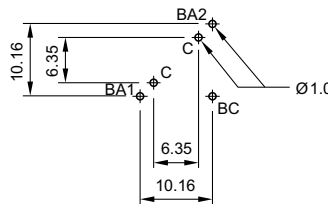

4 Switching element illuminative page 6

Single-LED

Drilling plan (Elementside)

- B Holes for LED
- C Holes for contact pins
Pad max. $\varnothing 2.5$ mm
Through-connection recommended

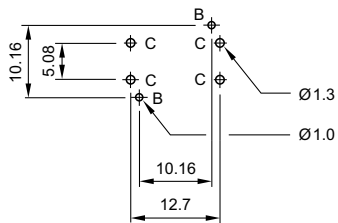

Bi-colour-LED

Drilling plan (Elementside)

- B Holes for Bi-colour-LED:
BA1 (green) + BA2 (yellow or red) = Anodes, BK = Cathode
- C Holes for contact pins
Pad max. $\varnothing 2.5$ mm
Through-connection recommended

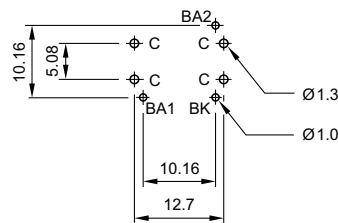

Technical drawing

1 Spacing cap page 7

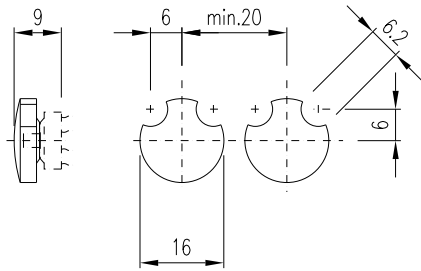

2 Spacing cap page 7

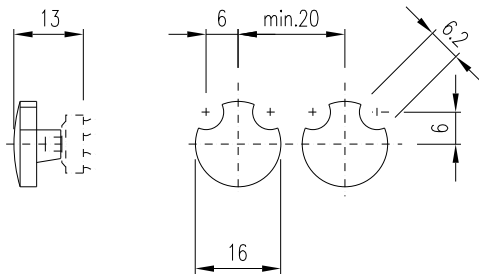

3 Spacing cap page 7

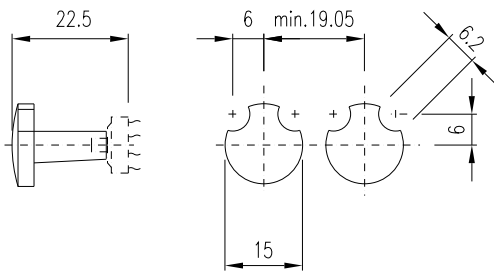

4 Spacing cap page 7

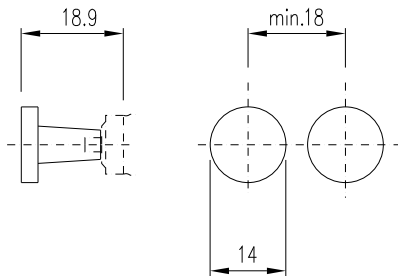

5 Lens page 7

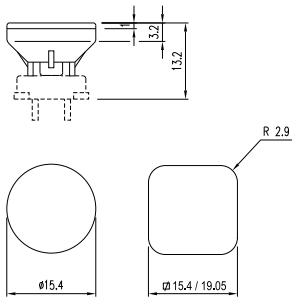

6 Lens page 7

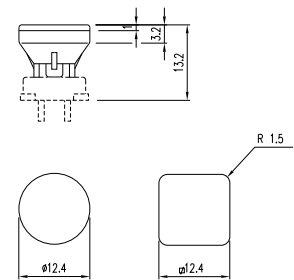

7 Switching element non-illuminated page 5

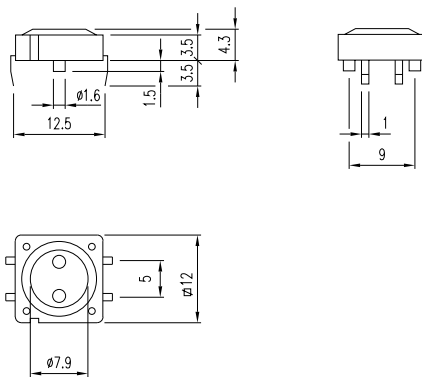

8 Switching element non-illuminated page 5

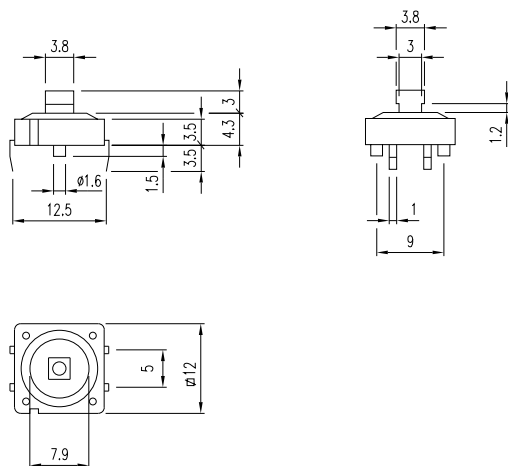

9 Switching element non-illuminated page 5

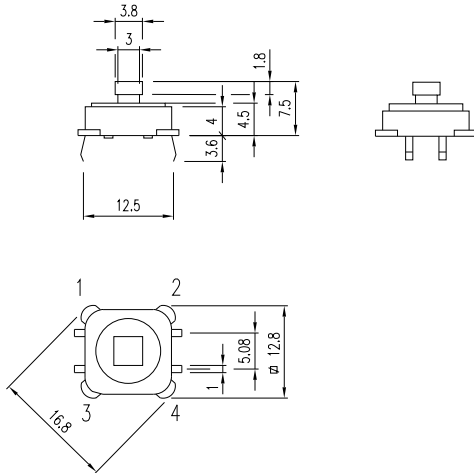

10 Illumination element page 5

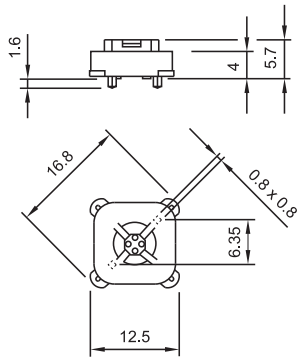

11 Switching element illuminative page 6

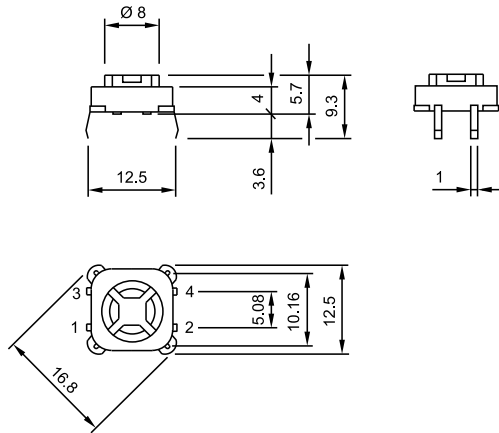

Circuit drawing

1 Illumination element page 5

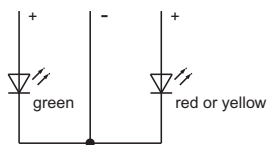

2 Switching element illuminative page 6

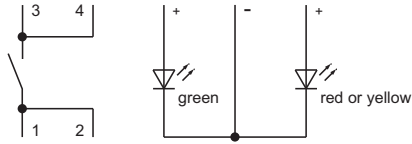

3 Illumination element page 5



4 Switching element non-illuminated page 5 | Switching element illuminative page 6

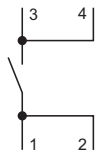

5 Switching element illuminative page 6

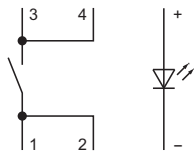

6 Switching element non-illuminated page 5

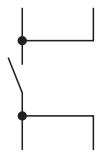

Index from Typ-Nr.

Typ-Nr.	Page	Typ-Nr.	Page	Typ-Nr.	Page
10-2602.3174D	7				
10-2602.3202L	7				
10-2602.3203L	7				
10-2602.3205L	7				
10-2602.3206L	7				
10-2602.3209L	7				
10-2603.320AL	8				
10-2603.320CL	8				
10-5609.3174D	8				
70-100.0	5				
70-101.0	5				
70-201.0	5				
70-220.2	6				
70-220.25	6				
70-220.3	6				
70-220.4	6				
70-220.45	6				
70-220.5	6				
70-220.6	6				
70-220.9	6				
70-820.2	5				
70-820.25	5				
70-820.3	5				
70-820.4	5				
70-820.45	5				
70-820.5	5				
70-820.6	5				
70-820.9	5				
70-901.0	7				
70-910.0	7				
70-911.0	7				
70-911.2	7				
70-911.3	7				
70-911.4	7				
70-911.5	7				
70-911.9	7				
70-912.0	7				
70-912.2	7				
70-912.3	7				
70-912.4	7				
70-912.5	7				
70-912.9	7				
70-920.9	7				
70-921.2	7				
70-921.3	7				
70-921.4	7				
70-921.5	7				
70-921.6	7				
70-921.9	7				
70-922.2	7				
70-922.3	7				
70-922.4	7				
70-922.5	7				
70-922.6	7				
70-922.9	7				
92-800.042	5				
92-851.342	6				

	EAO AG
	Tannwaldstrasse 88 4601 Olten, Switzerland
E-mail	info@eao.com
Website	www.eao.com
	Austria
Phone	+49 201 85 87 0
Fax	+49 201 85 87 210
E-mail	sales.ede@eao.com
	Belgium
Phone	+32 3 777 82 36
Fax	+32 3 777 84 19
E-mail	sales.ebl@eao.com
	China
Phone	+852 27 86 91 41
Fax	+852 27 86 95 61
E-mail	sales.ehk@eao.com
	France
Phone	+33 1 64 43 37 37
Fax	+33 1 64 43 37 49
E-mail	sales.esa@eao.com
	Germany
Phone	+49 201 85 87 0
Fax	+49 201 85 87 210
E-mail	sales.ede@eao.com
	Italy
Phone	+39 035 481 0189
Fax	+39 035 481 3786
E-mail	sales.eit@eao.com
	Japan
Phone	+81 3 5444 5411
Fax	+81 3 5444 0345
E-mail	sales.esj@eao.com
	Netherlands
Phone	+31 78 653 17 00
Fax	+31 78 653 17 99
E-mail	sales.enl@eao.com
	Sweden
Phone	+46 8 683 86 60
Fax	+46 8 724 29 12
E-mail	sales.esw@eao.com
	Switzerland
Phone	+41 62 388 95 00
Fax	+41 62 388 95 55
E-mail	sales.ech@eao.com
	United Kingdom
Phone	+44 1444 236 000
Fax	+44 1444 236 641
E-mail	sales.euk@eao.com
	USA
Phone	+1 203 877 4577
Fax	+1 203 877 3694
E-mail	sales.eus@eao.com
	Other Countries
Phone	+41 62 286 92 10
Fax	+41 62 296 21 62
E-mail	info@eao.com

EAO reserves the right to alter specifications without further notice

