



Compact Safety Switch Saves Space and is Ideal for a Variety of Doors

- Positive opening mechanism  and double insulation  approved by TÜV and BIA.
- Five-direction Operation Key.
- Approved by UL, CSA, BIA, and SUVA standards.
- Enclosure ratings: IP65 (EN60529), Type 4 (UL/CSA) (indoor use only).

Refer to **Precautions** on page 9.

- Approval:

Agency	Standard	File No.
TÜV Rheinland	EN60947-5-1 (positive opening)	R9551708
UL (see note)	UL508 CSA C22.2 No.14	E76675
BIA	GS-ET-15, EN60947-5-1	1-conduit: 9509915 2-conduit: 9509913
SUVA	SUVA	1-conduit: Nr.6010Z 2-conduit: Nr.6011Z

Note: CSA C22.2 No. 14 compliance was verified and approved by UL (Marked with ).

- Conformity:
Machine Directive
Low-voltage Directive
prEN1088



Ordering Information

Model Number Legend:

Switches

D4DS-□□□□

1 2 3 4

1. **Conduit**
 - 1: Pg13.5 (1-conduit)
 - 2: G1/2 (1-conduit)
 - 3: 1/2-14NPT (1-conduit)
 - 5: Pg13.5 (2-conduit)
 - 6: G1/2 (2-conduit)
2. **Built-in Switch**
 - 5: 1NC/1NO (Slow-action)
 - A: 2NC (Slow-action)

3. **Head Mounting Direction**
 - F: Front-side mounting
4. **Head Variation**
 - S: Standard













Operation Key

D4DS-K□

1



1. **Operation Key Type**
 - 1: Horizontal mounting
 - 2: Vertical mounting
 - 3: Adjustable mounting (horizontally adjustable)

Note: Note that any order for the head part or the switch part alone cannot be accepted. The Operation Key is sold separately.

Type	Conduit size	1NC/1NO (Slow-action)		2NC (Slow-action)		
		Positive opening	Model	Positive opening	Model	
1-conduit		Pg13.5		D4DS-15FS		D4DS-1AFS
		G1/2		D4DS-25FS		D4DS-2AFS
		1/2-14NPT		D4DS-35FS		D4DS-3AFS
2-conduit		Pg13.5		D4DS-55FS		D4DS-5AFS
		G1/2		D4DS-65FS		D4DS-6AFS

■ Accessories (Order Separately)

Operation Key

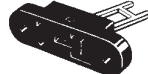
Mounting type	Model
Horizontal 	D4DS-K1
Vertical 	D4DS-K2
Adjustable (horizontal) 	D4DS-K3

Specifications

■ Ratings

Applicable Standards

TÜV and BIA (EN60947-5-1)

Utilization category	AC-15
Rated operating current (I_e)	2 A
Rated operating voltage (U_e)	400 V

UL (UL508/CSA C22.2 No.14) A600

Rated voltage	Current			Voltage • Ampere	
	Continuous	Make	Break	Make	Break
120 VAC	10 A	60 A	6 A	7,200 VA	720 VA
240 VAC		30 A	3 A		
480 VAC		15 A	1.5 A		
600 VAC		12 A	1.2 A		

General

Rated voltage	Non-inductive load				Inductive load			
	Resistive load		Lamp load		Inductive load		Motor load	
	NC	NO	NC	NO	NC	NO	NC	NO
125 VAC	10 A		3 A	1.5 A	10 A		5 A	2.5 A
250 VAC	10 A		2 A	1 A	10 A		3 A	1.5 A
400 VAC	10 A		1.5 A	0.8 A	3 A		1.5 A	0.8 A
8 VDC	10 A		6 A	3 A	10 A		6 A	
14 VDC	10 A		6 A	3 A	10 A		6 A	
30 VDC	6 A		4 A	3 A	6 A		4 A	
125 VDC	0.8 A		0.2 A	0.2 A	0.8 A		0.2 A	
250 VDC	0.4 A		0.1 A	0.1 A	0.4 A		0.1 A	

Note: The above current ratings are for a steady-state current.
 Inductive load has a power factor of 0.4 min. (AC) and a time constant of 7 ms max. (DC).
 Lamp load has an inrush current of 10 times the steady-state current.
 Motor load has an inrush current of 6 times the steady-state current.

■ Characteristics

Operating speed	0.1 m/s to 0.5 m/s
Contact gap	2 x 2 mm min.
Operating frequency	30 operations/min
Insulation resistance	100 MΩ min. (at 500 VDC) between terminals of same polarity, between terminals of different polarity, between each terminal and ground, and between each terminal and non-current-carrying metal part
Contact resistance	25 mΩ max. (initial value)
Dielectric strength	U_{imp} 4 kV between terminals of same polarity, between terminals of different polarity, between each terminal and ground, and between each terminal and non-current-carrying metal part (EN60947-5-1)
Rated insulation voltage (U_i)	400 V (EN60947-5-1)
Switching overvoltage	1,500 V max. (EN60947-5-1)
Pollution degree (operating environment)	3 (EN60947-5-1)
Short-circuit protective device (SCPD)	10 A, fuse type gI or gG (IEC269)
Conditional short-circuit current	100 A (EN60947-5-1)
Conventional enclosed thermal current (I_{the})	10 A (EN60947-5-1)
Protection against electric shock	Class II (double insulation)
Vibration resistance	Malfunction: 10 to 500 Hz, 0.65-mm single amplitude with an imposed acceleration of 100 m/s ² (10G) max.
Shock resistance	Destruction: 1,000 m/s ² min. (approx. 100G min.) Malfunction: 300 m/s ² min. (approx. 30G min.)
Life expectancy (see note 1)	Mechanical: 1,000,000 operations min. Electrical: 150,000 operations min.
Ambient temperature	Operating: -30°C to 70°C (with no icing)
Ambient humidity	Operating: 95% max.
Enclosure rating (see note 2)	IP65 (EN60947-5-1)
Weight	Approx. 76 g (for D4DS-15FS)

Note: The above mechanical life and electrical life are possible when the ambient temperature is 5°C to 55°C and the ambient humidity is 40% to 70%.

Although the Switch casing resists dust, oil, and water, make sure that the keyhole on the head is free from dust, oil, water, and chemical, otherwise the D4DS may wear out, break, or malfunction.

■ Operating Characteristics

Operating force (extraction)	29.42 N (3,000 gf)
Release force (insertion)	14.71 N (1,500 gf)
Pretravel	6±3 mm
Total travel (reference value)	28 mm
Min. positive opening force (see note)	58.84 N (6,000 gf)
Min. positive opening stroke (see note)	10 mm

Note: Make sure that the positive opening stroke is at least 10 mm in order to use the D4DS safely.

Nomenclature

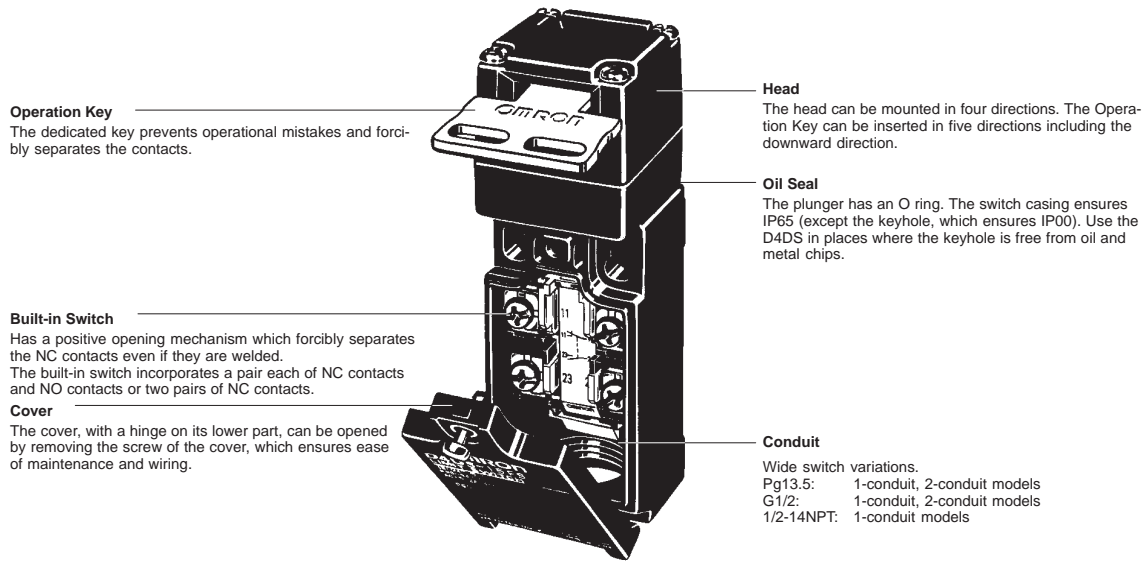

Note: The housing and head of the D4DS are made of synthetic resin. If high mechanical durability is required, use the D4BS Safety Door Switch.

Operation

■ Contact Form

Model	Contact	Diagrams	Remarks
D4DS-□5□S	1NC/1NO	 	Only NC contacts 11 and 12 have an approved positive opening mechanism.
D4DS-□A□S	2NC	 	NC contacts 11, 12, 21, and 22 have an approved positive opening mechanism.

Note: Terminals are numbered according to EN50013 and contacts are marked according to EN60947-5-1.

■ Positive Opening Mechanism

1NC/1NO Contact (Slow-action)

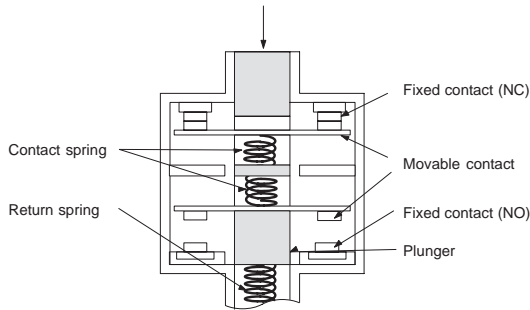

Only the NC contacts have a positive opening function. When metal deposition occurs, the contacts are separated from each other by pushing in the plunger.

Conforms to EN60947-5-1 Positive Opening

2NC Contact (Slow-action)

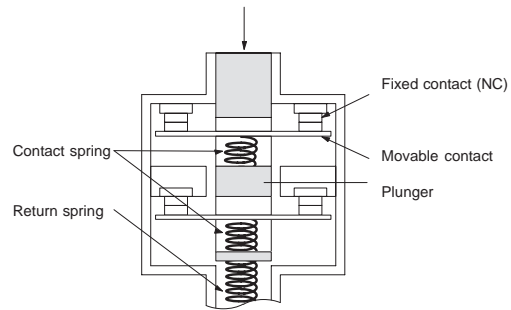

Both NC contacts incorporate a positive opening function. When metal deposition occurs, the contacts are separated from each other by pushing in the plunger.

Conforms to EN60947-5-1 Positive Opening

Note: The switches are marked with “” indicating approval for the positive opening mechanism.

Dimensions

Note: All units are in millimeters unless otherwise indicated.
 Unless otherwise specified, a tolerance of ± 0.4 mm applies to all dimensions.
 The conduit thread varies with the model as follows:

Conduit thread	Model
Pg13.5	D4DS-1□□S/-5□□S
G1/2	D4DS-2□□S/-6□□S
1/2-14NPT	D4DS-3□□S

1-conduit Models

- D4DS-1□□S
- D4DS-2□□S
- D4DS-3□□S

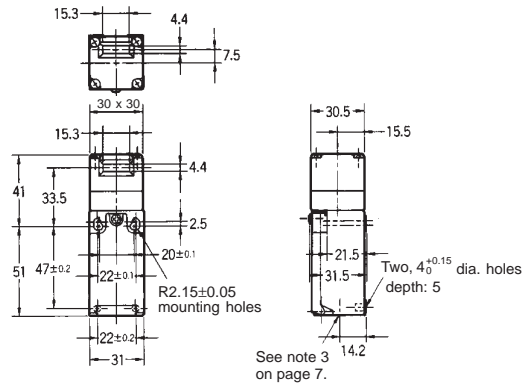

2-conduit Models

- D4DS-5□□S
- D4DS-6□□S

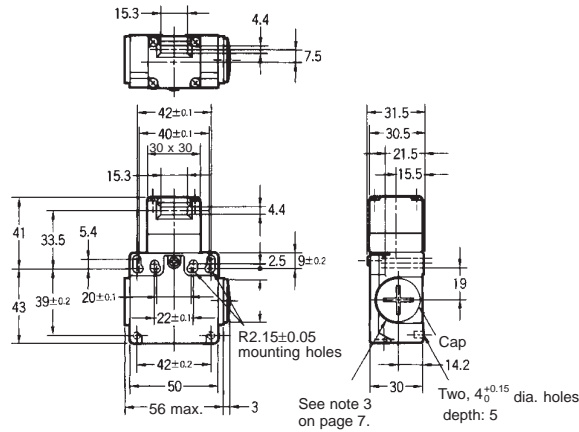

Operation Keys

D4DS-K1

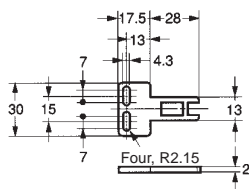
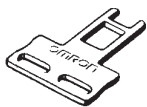

D4DS-K2

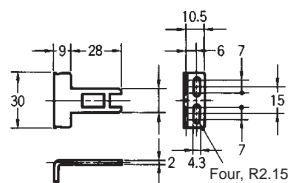
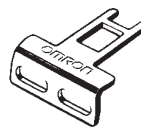

D4DS-K3

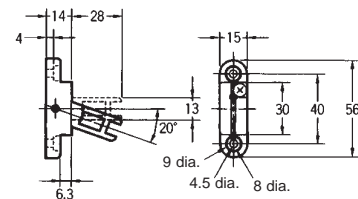
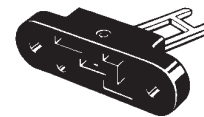

With Operation Key Inserted

- D4DS-1□□S + D4DS-K1
- D4DS-2□□S + D4DS-K1
- D4DS-3□□S + D4DS-K1
- D4DS-5□□S + D4DS-K1
- D4DS-6□□S + D4DS-K1

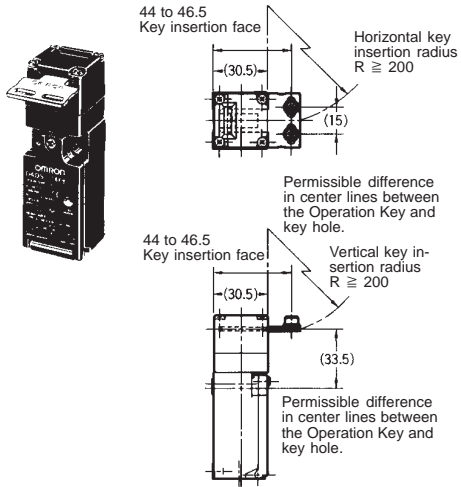

- D4DS-1□□S + D4DS-K2
- D4DS-2□□S + D4DS-K2
- D4DS-3□□S + D4DS-K2
- D4DS-5□□S + D4DS-K2
- D4DS-6□□S + D4DS-K2

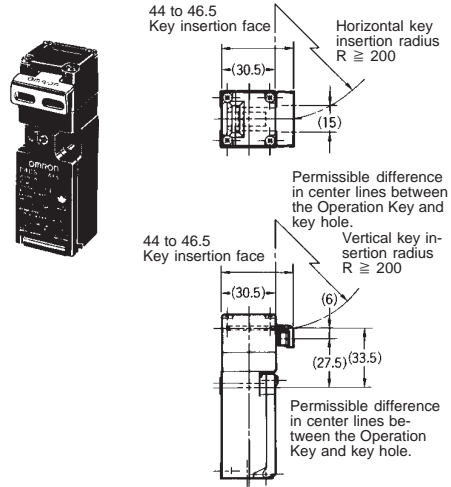

- D4DS-1□□S + D4DS-K3
- D4DS-2□□S + D4DS-K3
- D4DS-3□□S + D4DS-K3
- D4DS-5□□S + D4DS-K3
- D4DS-6□□S + D4DS-K3

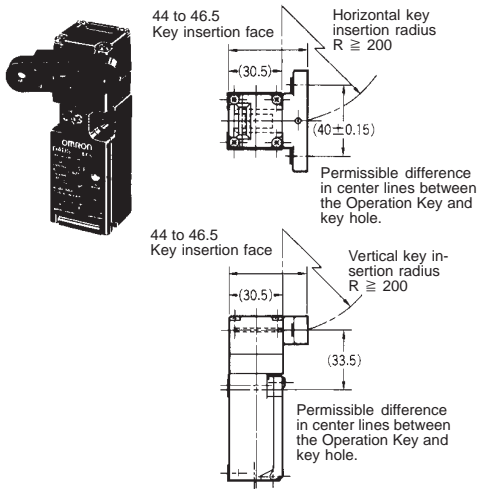

Precautions

Warnings

 WARNING
Do not remove the operation key from the door, or insert it to the switch with the door open. Machine may start operating.
Do not disassemble or touch inside under power-on. Electrical shock hazard may be caused.
Do not use metal connector or conduit with this switch. Electrical shock hazard may be caused.
Install the operation key so that it will not hit the operator when the door is open. Injury may be caused.

NOTICE

Protect the D4DS with an appropriate cover and post a warning sign near the D4DS, otherwise the D4DS or Operation Key may be removed carelessly and may result in serious injury due to the unexpected operation of the machine

To prevent the D4DS from damage due to short-circuits, connect the D4DS in series to a fuse that has a breaking current 1.5 to 2 times the rated current of the D4DS. If the D4DS is used under EN-approved rating conditions, use a 10 A fuse type gI or gG conforming to IEC 269.

Do not touch the live switch terminal. Electric shock may be caused. Be sure to evaluate the Switch under actual working conditions after installation.

Use OMRON's D4BS Switch under conditions requiring more robustness, sealing ability, and oil-tightness.

Operating Environment

The D4DS is for indoor use only. Do not use the D4DS outdoors. Otherwise, the D4DS may malfunction.

Operation Key

Be sure to use the dedicated Operation Key only.

Do not operate the D4DS with anything other than the dedicated Operation Key. Otherwise, the safety of the system may not be maintained.

Do not impose excessive force on the Operation Key inserted into the D4DS or drop the D4DS with the Operation Key inserted. Otherwise, the Operation Key may be deformed or broken.

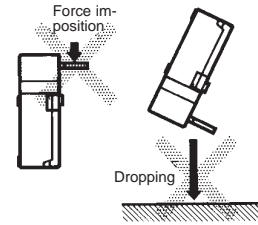

Secure the Operation Key with a one-way screw, or an equivalent, so that the Operation Key cannot be easily removed.

Mounting

When applying the D4DS to the door of a machine room, be sure to provide a stopper for the door as shown in the following illustration. Do not use the Switch as a stopper. Adjust the mounting position of the Operation Key so that the Operation Key will be within the 3-mm lock range of the D4DS when the door is closed (i.e., the distance (a) in the following illustration is within 3 mm).

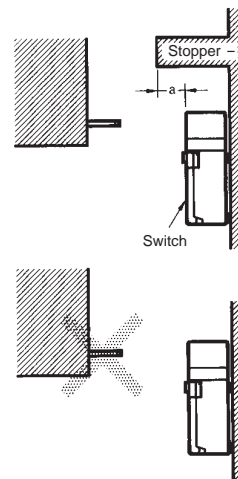

Refer to page 7 for the mounting dimensions of the Operation Key. Be sure that the Operation Key can be inserted properly with a tolerance of ± 1 mm in the upward, downward, left, or right direction, otherwise the D4DS may be damaged.

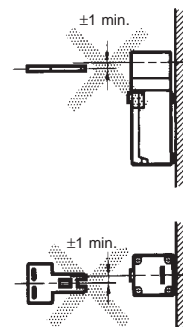

Tightening Torque

Be sure to tighten each screw of the D4DS properly, otherwise the D4DS may malfunction.

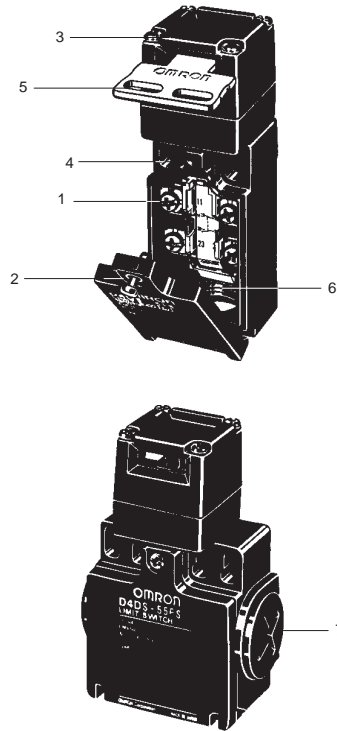

	Type	Proper tightening torque
1	Terminal screw (M3.5)	0.59 to 0.78 N • m (6 to 8 kgf • cm/0.43 to 0.58 ft • lbf)
2	Cover mounting screw	0.78 to 0.88 N • m (8 to 9 kgf • cm/0.58 to 0.65 ft • lbf)
3	Head mounting screw	0.78 to 0.88 N • m (8 to 9 kgf • cm/0.58 to 0.65 ft • lbf)
4	Body mounting screw (M4) (see note)	0.49 to 0.69 N • m (5 to 7 kgf • cm/0.36 to 0.51 ft • lbf)
5	Operation Key mounting screw	2.35 to 2.75 N • m (24 to 28 kgf • cm/1.73 to 2.03 ft • lbf)
6	Connector at conduit opening	1.77 to 2.16 N • m (18 to 22 kgf • cm/1.30 to 1.59 ft • lbf)
7	Cap screw	1.27 to 1.67 N • m (13 to 17 kgf • cm/0.94 to 1.23 ft • lbf)

Note: Tighten each screw together with a washer to the specified torque.

Mounting

Be sure the that D4DS operates properly after mounting and adjusting the D4DS.

Switch Mounting Holes

The Switch and Operation Key are fastened to the specified torque (on page 10) with M4 screws (one-way screw etc.) and washers.

Mounting Holes/Studs

1-conduit

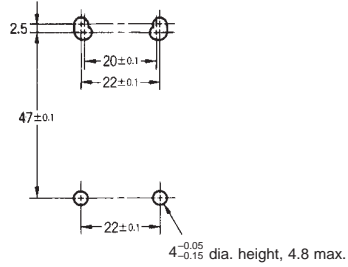

2-conduit

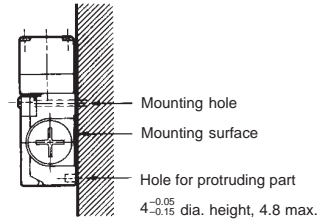
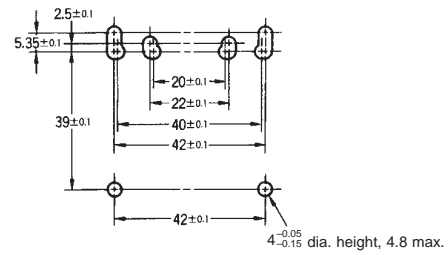

Operation Key Mounting Holes

Horizontal/Vertical Mounting (D4DS-K1/-K2)

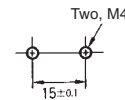

Adjustable Mounting (D4DS-K3)

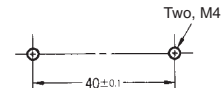

Head Direction

By removing the four screws of the head, the mounting direction of the head can be changed. The head can be mounted in four directions.

When changing the direction of the head, be sure that the Operation Key is inserted into the head and no foreign material will enter during a change in direction.

Do not remove any internal screw from the head, otherwise the internal parts of the head may become lost or deformed.

Wiring

Do not connect lead wires directly to the terminals. Be sure to connect the lead wires through insulation tubes and crimp terminals. The tightening torque applied to each crimp terminal is 0.59 to 0.78 N • m (6 to 8 kgf • cm). The lead wires must be an AWB20 to AWG14 type (i.e., 0.5 to 2.5 mm² thick).

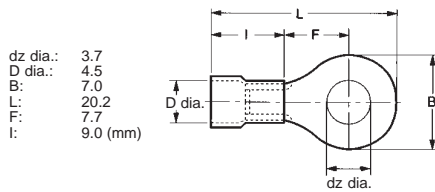

Wire the crimp terminal as shown in the following diagram so that it will not come in contact with the case or cover.

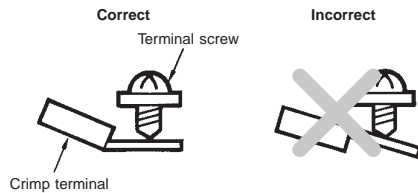

Conduit Opening

The torque required to tighten a connector other than a 1/2-14NPT connector is 1.77 to 2.16 N • m (18 to 22 kgf • cm). The torque required to tighten a 1/2-14NPT connector is 1.37 to 1.77 N • m (14 to 18 kgf • cm).

The casing may be damaged if an excessive tightening torque is applied. For the casing to maintain IP65, apply sealing tape between the connector and conduit opening. Be sure that the diameter of the cable connected to the connector is correct.

When wiring a 2-conduit model, attach and tighten a conduit cap to the unused conduit opening. The torque to be applied to the conduit cap is 1.27 to 1.67 N • m (13 to 17 kgf • cm). The conduit cap is provided with the D4DS.

Recommended Connectors

Size	Manufacturer	Model	Cable diameter
G ¹ / ₂	OMRON	SC-6	7.5 to 9.0 mm
	LAPP	ST-PF1/2 5380-1002	6.0 to 12.0 mm
	Ohm Denki	OA-W1609	7.0 to 9.0 mm
Pg13.5	LAPP	ST13.5 5301-5030	5.0 to 12.0 mm
	HEYCO	3216	4.3 to 11.9 mm
1/2-14NPT	LAPP	ST-NPT1/2 5301-6030	6.0 to 12.0 mm
	HEYCO	3231	4.3 to 11.9 mm

Note: LAPP is a German manufacturer.
Ohm Denki is a Japanese manufacturer.
HEYCO is an American manufacturer.

Maintenance and Repairs

Users must not repair or maintain the D4DS. Contact your OMRON representative for any repairs or maintenance.

Others

Be sure that no metal dust, oil, or chemical will be sprayed onto the D4DS, otherwise the D4DS may malfunction.

The head uses grease internally, which may have a bad influence on semiconductor products. When using the D4DS for the door of a semiconductor product manufacturing room, mount the D4DS to the outer side of the door.

ALL DIMENSIONS SHOWN ARE IN MILLIMETERS.

To convert millimeters into inches, multiply by 0.03937. To convert grams into ounces, multiply by 0.03527.

Cat. No. C104-E1-2 **In the interest of product improvement, specifications are subject to change without notice.**

OMRON Corporation

Control Components Division H.Q.
28th Fl., Crystal Tower Bldg.
1-2-27, Shiromi, Chuo-ku,
Osaka 540 Japan
Phone: 06-949-6115 Fax: 06-949-6134

Printed in Japan
0897-1M (0696) a