

ATTRACTIVE AND RUGGED FOR WET AND DUSTY ENVIRONMENTS

The OTTO K3 series is a quality, precision switch designed to comply with standards established for appliance, marine (ignition protection) and off-road vehicles along with other demanding applications where rugged rocker switches are required.

K3 series sealed rocker switches snap into industry-standard panel cutouts. Choose illuminated and printed legends, thru-panel drain option, and switching compatibility from low level to 20 amps.

The K3 series offers a choice of LED, incandescent and neon illumination. Legends can be stamped onto a non-illuminated button, stamped onto an illuminated lens, or laser etched into the lens and backlit.

Available in standard and low level contact ratings, the K3 rockers will fit a wide range of applications. Expect a minimum of 25,000 cycles at a full rated load of 20 amps resistive or 15 amps inductive. 100,000 cycles are possible at low level loads. A full complement of switch operation is available including momentary and maintained action in 2- or 3-position switches in SPST, SPDT, SPTT, DPST, and DPDT circuit arrangements.

OTTO can provide custom colors upon request. Value-added assemblies with wire leads are also available. Please consult the factory for assistance.

Quality Features:

- Submersible, sealed watertight per IP68
- Snap-in panel mounting into industry standard panel cutout
- Optional panel seal gasket
- Thru-panel drain option
- LED, neon and incandescent lighting
- .250" Q.C. terminals
- Optional one-piece connector
- Optional terminal barriers
- Low level to 20 amp switch



Standard Characteristics/Ratings:

OPERATIONAL:

Mechanical Life:	100,000 cycles, minimum
Seal:	Watertight. Submersible to IP68
Operating Temperature Range:	-40°C to +85°C
Button/Case:	Thermoplastic.
Mounting:	Snap-In from front into industry standard panel cutout
Contacts:	Silver Alloy. Gold flash for low level
Terminals:	Brass 1/4" Q.C. Standard
Light Source:	6V, 12V, 24V Incandescent; 125V, 250V Neon; 2V, 6V, 12V, 24V red, green, amber LED

ELECTRICAL:

LOAD Type	CURRENT RATING		LIFE (Min.)
	12V & 28V	110VAC	
Resistive	20A	16A	25,000 cycles
Inductive	15A	15A	25,000 cycles
Lamp	5A	5A	25,000 cycles
Motor Load:	1/2 HP at 110 VAC		
Dielectric Withstand:	1050 Vrms except across light terminals		

Compliance Standards (Pending):

EN61508-1 for appliance switches
 UL 1054 for special use switches
 UL 1500 for ignition protection of marine products
 SAE J1455 for heavy duty trucks

SEALED, ILLUMINATED ROCKER SWITCHES

SNAP-IN PANEL MOUNTING

Standard Legends Per SAE Specifications

A1 	ANCHOR	K2 	UNLOCK	P5 	BILGE BLOWER
B1 	BATTERY	L1 	LIGHT	R1 	LIFT
B2 	ELECTRIC POWER	L2 	MASTER LIGHTING SWITCH	R2 	LOWER
C1 	AC/COOLING SYSTEMS	L3 	HEADLIGHTS	R3 	UP
C2 	DEHUMIDIFIER	L4 	HEADLIGHTS-LOW / DIPPED BEAM	R4 	DOWN
C3 	HEATER/INTERIOR HEATING	L5 	HEADLIGHTS-HIGH / UPPER BEAM	R5 	RIGHT
D1 	WINDSHIELD DEFROSTER	L6 	PARKING LIGHT	R6 	LEFT
D2 	REAR WINDOW DEFROSTER	L7 	WORK LAMP	R7 FWD	FORWARD
D3 	MIRROR DEFROSTER	L8 	WORK LAMP	R8 REV	REVERSE
E1 	ENGINE/START	L9 	INTERIOR DOME LIGHT	S1 	RADIO
E2 	ENGINE/STOP	M1 	BEACON	S2 	MUTE
E3 	ON/START	M2 	HAZARD/POSITION LIGHTS	T1 	FAST
E4 	OFF/STOP	M3 	CLEARANCE LIGHTS	T2 	SLOW
E5 ON	ON	M4 	SIDE MARKER LIGHT	T3 	TRIM TAB / TRIMMING OPERATION
E6 OFF	OFF	M5 	RUNNING LIGHTS (UNDER POWER)	T4 	TRANSMISSION
E7 	ENGINE ELECTRIC PREHEAT	M6 	ANCHOR LIGHT	V1 	VENTILATING / AC FAN
E8 	ENGINE-GAS INJECTION	M7 	RUNNING/ANCHOR LIGHTS	W1 	WINDSHIELD WIPER
F1 	FRONT FOG LIGHTS	M8 	SEARCH LIGHT	W2 	WINDSHIELD-WASHER
F2 	REAR FOG LIGHTS	M9 	LEFT TURN SIGNAL	W3 	WINDSHIELD-WASHER/WIPER
G1 	FUEL	MA 	RIGHT TURN SIGNAL	W4 	REAR WINDOW WIPER
H1 	HORN	P1 	BILGE PUMP #1	W5 	REAR WINDOW-WASHER
H2 	HORN REAR	P2 	BILGE PUMP #2	W6 	REAR WINDOW-WASHER/WIPER
K1 	LOCK	P3 	BILGE PUMP #3	ZZ	NO LEGEND
		P4 	BILGE PUMP		

For legends not shown, please consult an OTTO representative.

SNAP-IN PANEL MOUNTING

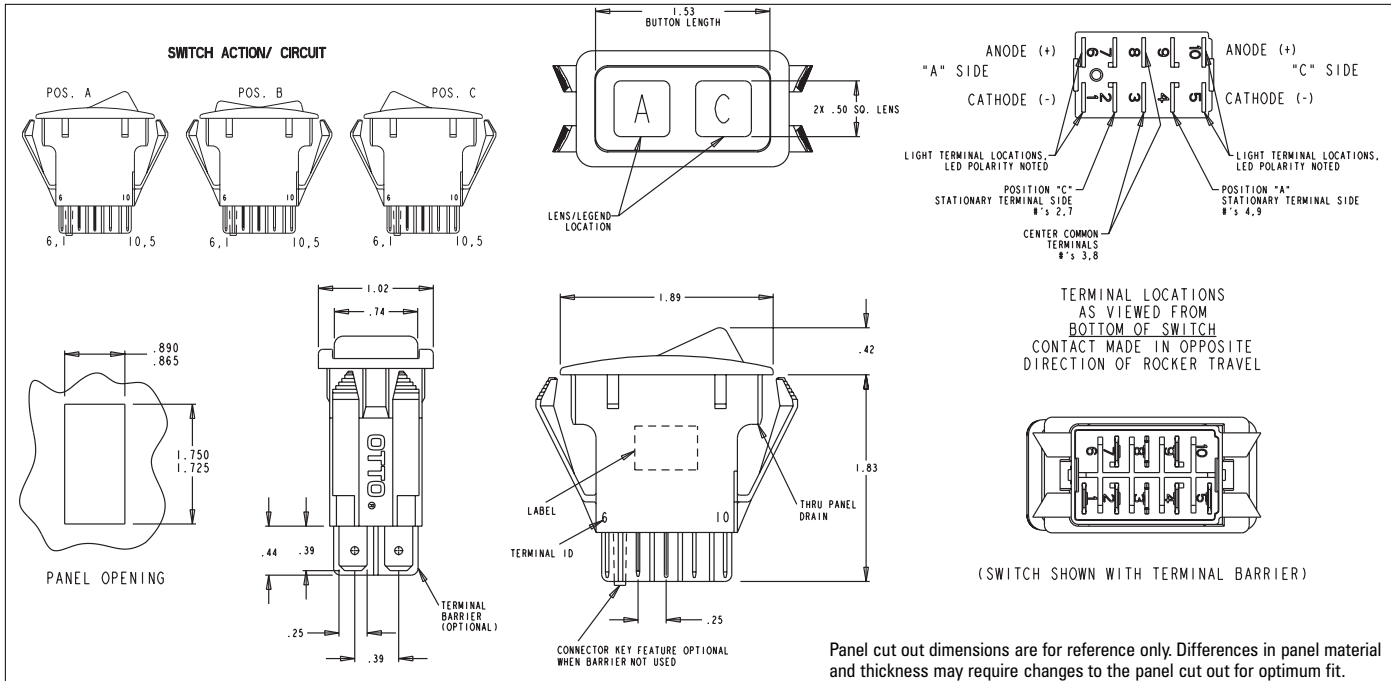

K3 Series PART

K3 X X XX X X

Terminal Style/ Switch Rating/Plating	Bezel and Actuator Color and Case Style	Code	Switch Action/Circuit			Light Source Type	Light Circuit
			Position "A"	Position "B"	Position "C"		
A. Without Terminal Barriers/ Standard Rating/Silver Plating	A. Black Rocker and Bezel with Drain Holes	1A	ON	NONE	OFF	SPST	A. No Light
B. Without Terminal Barriers & Connector Keying Pin/ Standard Rating/Silver Plating	B. Black Rocker and Bezel without Drain Holes	1B	ON	NONE	ON	SPDT	B. Dep. in "A"
C. With Terminal Barriers/ Standard Rating/Silver Plating	C. Red Rocker and Bezel with Drain Holes	1C	MOM-ON	NONE	OFF	SPST	C. Dep. in "C"
D. Without Terminal Barriers/ Low Level Rating/Gold Plating	D. Red Rocker and Bezel without Drain Holes	1D	MOM-ON	NONE	ON	SPDT	D. Ind. in "A"
E. Without Terminal Barriers & Connector Keying Pin/Low Level Rating/Gold Plating	E. White Rocker and Bezel with Drain Holes	1E	MOM-ON	OFF	MOM-ON	SPDT	E. Ind. in "C"
F. With Terminal Barriers/Low Level Rating/Gold Plating	F. White Rocker and Bezel without Drain Holes	1F	ON	OFF	ON	SPDT	F. Dep. in "A" & "C"
G. Without Terminal Barriers/ Standard Rating/No Plating		1G	MOM-ON	OFF	ON	SPDT	G. Dep. in "A" & Ind. in "C"
H. Without Terminal Barriers & Connector Pin/Standard Rating/ No Plating		1H	ON	ON	OFF	SPDT	H. Ind. in "A" & Dep. in "C"
J. With Terminal Barriers/Standard Rating/No Plating		1J	ON	ON	NONE	SPDT	J. Ind. in "A" & "C"
		1K	MOM-ON	ON	OFF	SPDT	
		1L	MOM-ON	ON	NONE	SPDT	
		1M	ON	ON	ON	SPTT	
		1N	MOM-ON	ON	ON	SPTT	
		1P	MOM-ON	ON	MOM-ON	SPTT	
		2R	ON/ON	OFF/ON	OFF/OFF	DPDT	
		2S	MOM-ON/ON	OFF/ON	OFF/OFF	DPDT	

NOTE: Silver Plating for Soldering

Stop Here for unlighted switches without legends. The switch you have specified will be supplied with a rocker button without lenses and without legends. Example: K3AA1FAA

SEALED, ILLUMINATED ROCKER SWITCHES

ATTRACTIVE AND RUGGED FOR WET & DUSTY ENVIRONMENTS

Part Numbering Example:

K3DB1ENJ-21T1T2994

Switch Description

K3 rocker switch

for low level switching, without terminal barriers

featuring a black rocker and bezel without drain holes

in a SPDT, Mom On – Off – Mom On circuit arrangement

with 12VDC red LEDs

lit independently in both positions

Switch Description

- K3
 - D
 - B
 - 1E
 - N
 - J
 -
 - 2
 - 1
 - T1
 - T2
 - 9
 - 9
 - 4
- Green lens in Position A and a Red lens in Position C are respectively pad-printed with Rabbit Legend in Position A Turtle legend in Position B both in white with the legends rotated 270° so that the switch can be mounted in the panel vertically with the Rabbit at the top of the switch

NUMBERING CODE

	X	X
	Lens Color	
Position "A"		Position "C"
1. Transparent Red	1. Transparent Red	
2. Transparent Green	2. Transparent Green	
3. Transparent Amber	3. Transparent Amber	
4. Clear	4. Clear	
5. Translucent White	5. Translucent White	
Z. No Lens	Z. No Lens	

* Use with neon lamps

Stop Here for lighted switches without legends. The switch you have specified will be supplied with a rocker button with lenses, but without legends.
Example: K3AAIFNH-44

Note

It is not recommended to use green LEDs with translucent white lenses. This will reduce light intensity.

XX	XX	X	X	X
Legend Style		Legend Color		Legend Rotation
Position "A"	Position "C"	Position "A"	Position "C"	
List "ZZ" in each position for no legend		1. Red	1. Red	1. Standard
Refer to Legend Table for Legend Codes.		2. Black	2. Black	2. 90°
		9. White	9. White	3. 180°
		B. Backlit/Daylight White	B. Backlit/Daylight White	4. 270°
		D. Backlit/Deadfront	D. Backlit/Deadfront	
		Z. No Legend	Z. No Legend	

POSITION "A"

POSITION "C"

Connector: Part Number 801775-2A without latches.
Part Number 801775-2B with latches.

Panel Seal Gasket: Part Number 807037.
Order separately for use with switches without drain holes.

Panel Plug: Part Number K300000040.