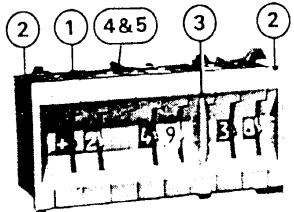
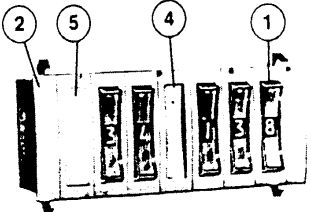
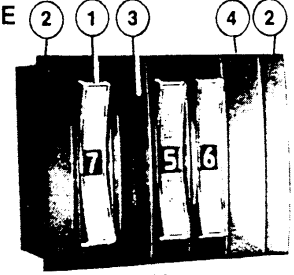
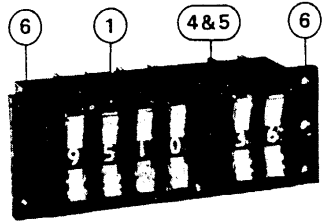
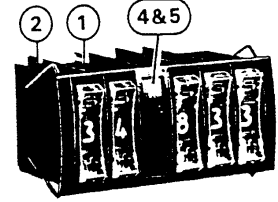
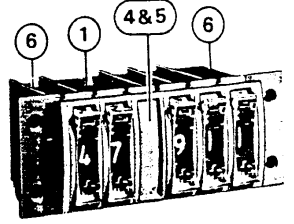
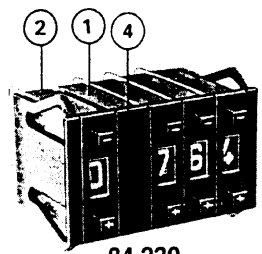
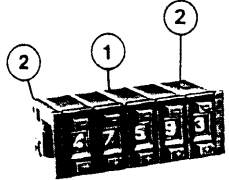
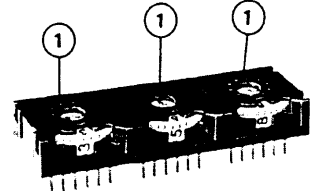

103 810 40 620

Index

<p>STANDARD</p>  <p>84 210 Thumbwheel Standard – Panel Mount Page 5</p>	<p>STANDARD</p>  <p>84 211 Rocker Standard – Panel Mount Page 6</p>	<p>LARGE</p>  <p>84 212 Rocker Large – Panel Mount Page 7</p>
<p>STANDARD</p>  <p>84 213 Rocker Standard – Rear Mount Page 8</p>	<p>MINIATURE</p>  <p>84 214 Rocker Miniature – Panel Mount Page 9</p>	<p>MINIATURE</p>  <p>84 218 Rocker Miniature – Rear Mount Page 10</p>
<p>MINIATURE</p>  <p>84 230 Push Button Miniature – Panel Mount Page 12</p>	<p>SUBMINIATURE</p>  <p>84 231 Push Button Subminiature – Panel Mount Page 13</p>	 <p>84 235 Thumbwheel PCB – Flat Mount Page 14</p>

- 1 – **Basic Module:** Enable data input in coded form.
- 2 – **End Caps:** Snap into place to complete module assembly. Complete with 4 panel clips.
- 3 – **Separator:** Used to fit 2 switch assemblies into one unit. They come with 2 clips.
- 4 – **Spacer:** Blank module used to replace a module assembly.
- 5 – **Encoded “Dummy” Module:** Enables simultaneous switching to two circuits from one digital switch, it is driven by the adjacent module via a coupling shaft.
- 6 – **End Caps:** For rear mounting of module assembly. They come in pairs.

Other Index Items	Page
General Information	3
Truth Tables	11 & 15
How To Order – (Switches)	16
L.E.D. Readout	17-22
How To Order – (L.E.D. Readouts)	23

General Information

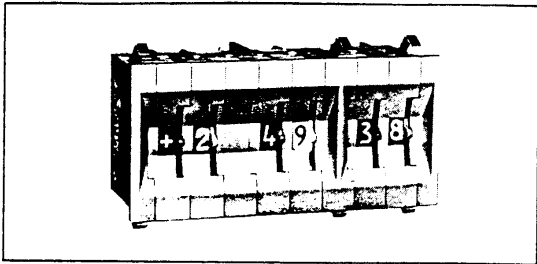

Wheel Marking

- Large size figures or symbols give maximum readability.
- Complies with European Aeronautics standard BN Aë – NFL 70130.
- Special markings are available on request.

Assembly Series: 84210, 84211, 84212, 84213, 84214, 84218

- Modules snap into place – easily disassembled
- No mounting hardware needed

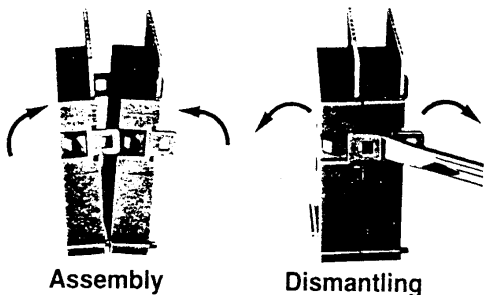

Assembly Series: 84230, 84231, 84235

- Snap fit – No tools, no hardware

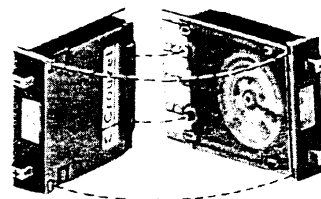

Clip Mounting Series 84210, 48211, 84212, 84213, 84214, 84218

- Two clip assembly combination available: Panel thickness – .06 - .14 in. (1.5 - 3.5mm) Panel thickness – .126 - .24 in. (3.2 - 6mm).
- Clips supplied in pairs with end plates or spacers.

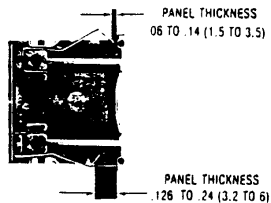

Dimensions in inches (mm)

Series 84230, 84231, 84235

- No clip mounting necessary
- Clips molded in end caps

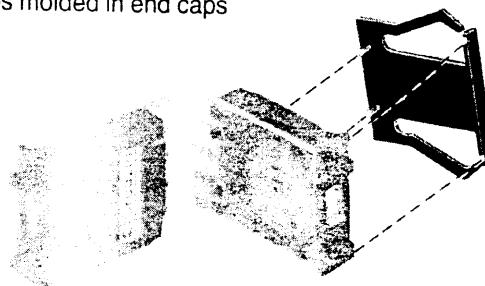

Colors

- Standard modules come in black (grey upon request).
- Standard wheels are black or red with white markings.
- Optional wheels: (except series 84230, 84231, 84235) Green or blue with white markings. Yellow with black markings

Dial Stops

- Limit the rotation of the dial to any number of positions, to be specified when ordering.

Circuit Boards

- All our digital switches are provided with printed circuit boards made of glass-filled P.C. 75 epoxy composite board, .03 in. (.08 mm) thick, covered with copper plated with nickel and gold.
- Two types of circuit boards are available: Short for direct connection or long for component mounting such as resistors or diodes, in series or parallel. (See photos).
- **Note** 84231 – MO1 and MO3: no long circuit board and no hole on circuit available.

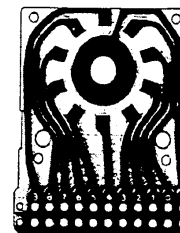
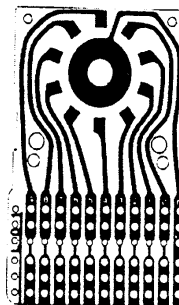
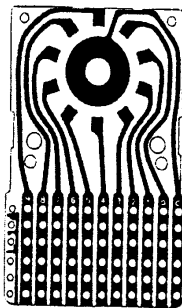

Switch Terminations and Connectors

Terminals

- Three types of terminations:
 Direct soldering or plug-in for connectors (S)
 Pins for wire wrapping (X2) – Except Series 84230, 84231, 84235
 Pins for P.C. board soldering (X3).

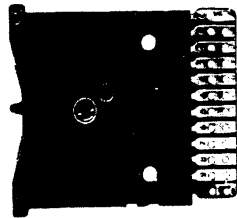

S

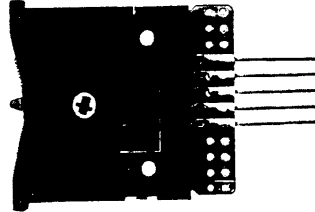

X2

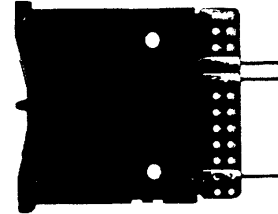

X3

Connectors (for Series 84210, 84211, 84212, 84213)

- Connectors available:
 Solder terminals (W2)
 Wire wrap terminals (X2)
 P.C. board solder terminals (X3).

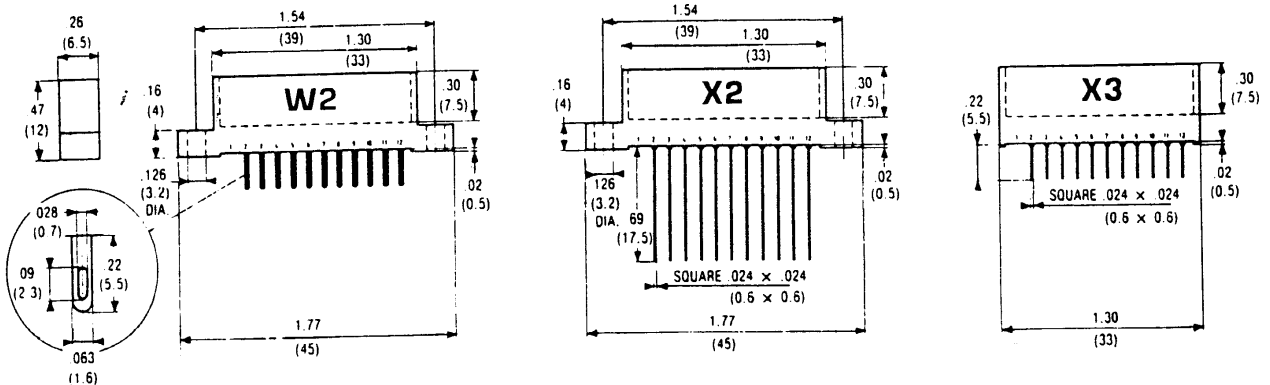
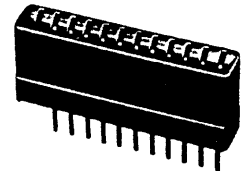
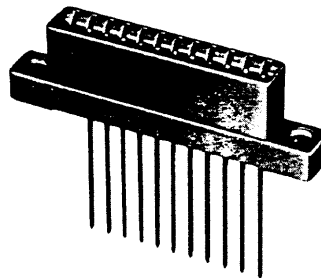
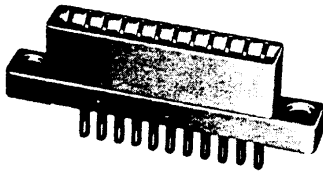

Dimensions in inches (mm)

Thumbwheel - standard - panel mount Series 84 210

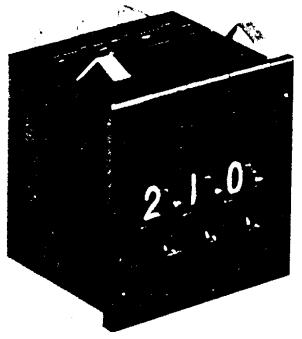

- Large numerals — .18 in. (4.5 mm) high
- All modules easily assembled without hardware
- Black or red wheels standard—other colors on request
- Right-sided circuits — left-sided optional
- Modules will accommodate our L.E.D. readouts

Mechanical & Electrical Specifications		Materials
Operating Voltage: .1 to 250 V AC .1 to 50 V DC Nominal Electrical Load (Resistive Load): .1 mA to 100 mA Maximum Non-Switching Load: 1 A Contact Resistance: 70 mΩ max. Life at 50 V DC, .1 A, Resistive Load: 1 million operations Note: For voltages and currents less than the above values, please consult us.	Dielectric Strength: 600 V Operating Temperatures: —13° F. to 158° F. (—25° C. to 70° C.) Storage Temperatures: —40° F. to 185° F. (—40° C. to 85° C.) Dial Character Dimensions: .18 in. x .11 in. (4.5 mm x 2.8 mm) Operating Torque: 10 oz. (300 g)	Case: Noryl Wheel: Delrin Contacts and Tracks: Copper—Nickel—Gold Brush: Beryllium bronze Printed Circuit Board: Glass-filled epoxy (P.C. 75)

Option: The P.C. boards of the standard 84 210 type modules are mounted on the right side of the module. The decimal and BCD codes can, optionally, be mounted onto the left side of the module. In this case the outputs are as shown below. Please contact us.

<p>Standard:</p> <p>Option:</p> <p>Decimal M 09</p> <p>BCD M10</p>	<p>Dimensions in inches (mm)</p>
--	---

Crouzet® Digital Switches

Rocker Switch - standard - panel mount Series 84 211

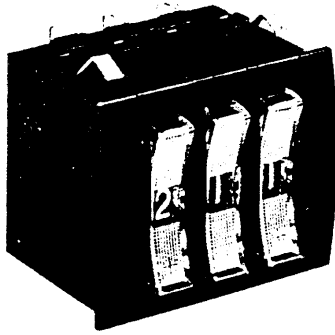

- Fast switching in both directions
- Large numerals — .18 in. (4.5 mm) high
- All modules easily assembled without hardware
- Good looking—easy to read
- Black or red wheels standard — other colors on request

Mechanical & Electrical Specifications

Operating Voltage: .1 to 250 V AC
.1 to 50 V DC

Nominal Electrical Load (Resistive Load):
.1 mA to 100 mA

Maximum Non-Switching Load: 1 A

Contact Resistance: 70 mΩ max.

Life at 50 V DC, .1 A, Resistive Load: 1 million operations

Note: For voltages and currents less than the above values, please consult us.

Dielectric Strength: 600 V

Operating Temperatures: —13° F. to 158° F. (—25° C. to 70° C.)

Storage Temperature: —40° F. to 185° F. (—40° C. to 85° C.)

Dial Character Dimensions: .18 in. x .11 in. (4.5 mm x w.8 mm)

Operating Force at End of Rocker: 17 oz. (500 g)

Materials

Case: Noryl

Wheel: Delrin

Rocker Actuator: Makrolon* (Polycarbonate)

Contacts and Tracks: Copper—Nickel—Gold

Brush: Beryllium bronze

Printed Circuit Board: Glass-filled epoxy (P.C. 75)

*Special elements not used in other manufacturers' products.

Dimensions in inches (mm)

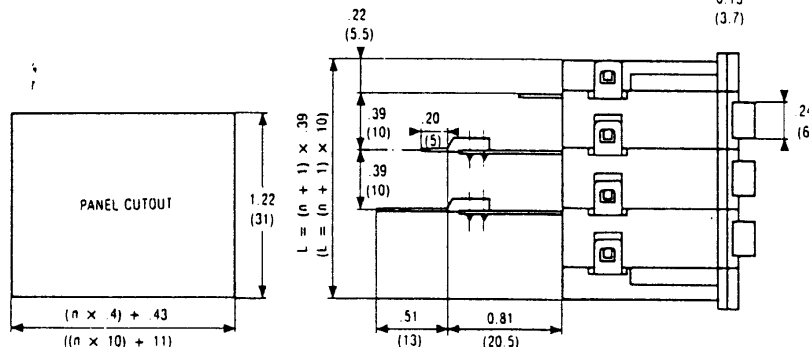
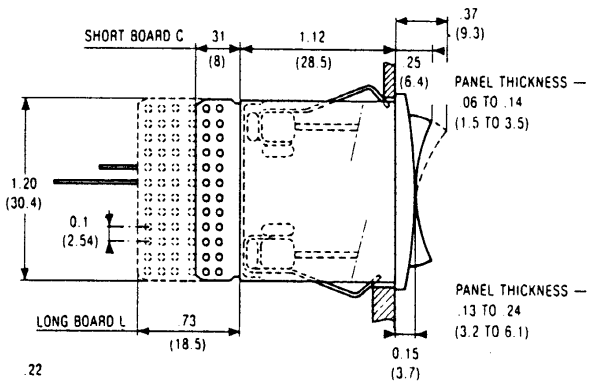
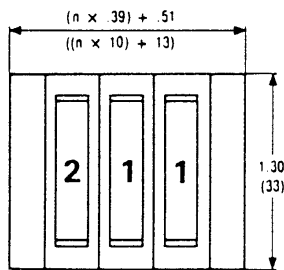

Rocker Switch - large - panel mount Series 84 212

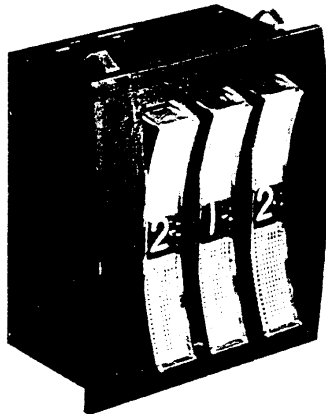

- Fast switching with large rocker actuator
- Extra large numerals — .24 in. (6 mm) high for easy reading
- All modules easily assembled without hardware
- Attractive

Mechanical & Electrical Specifications

Operating Voltage: .1 to 250 V AC
.1 to 50 V DC

Nominal Electrical Load (Resistive Load):
.1 mA to 100 mA

Maximum Non-Switching Load: 1 A

Contact Resistance: 70 mΩ max.

Life at 50 V DC, .1A, Resistive Load: 1 million operations

Note: For voltages and currents less than the above values, please consult us.

Dielectric Strength: 600 V

Operating Temperatures: —13° F. to 158° F.
(—25° C. to 70° C.)

Storage Temperatures: —40° F. to 185° F.
(—40° C. to 85° C.)

Dial Character Dimensions: .24 in. x .15 in.
(6 mm x 3.75 mm)

Operating Force at End of Rocker:
10 oz. (300 g)

Materials

Case: Noryl

Wheel: Delrin

Rocker Actuator: Makrolon*
(Polycarbonate)

Contacts and Tracks: Copper—Nickel—Gold

Brush: Beryllium bronze

Printed Circuit Board: Glass-filled epoxy (P.C. 75)

*Special elements not used in other manufacturers' products.

Dimensions in inches (mm)

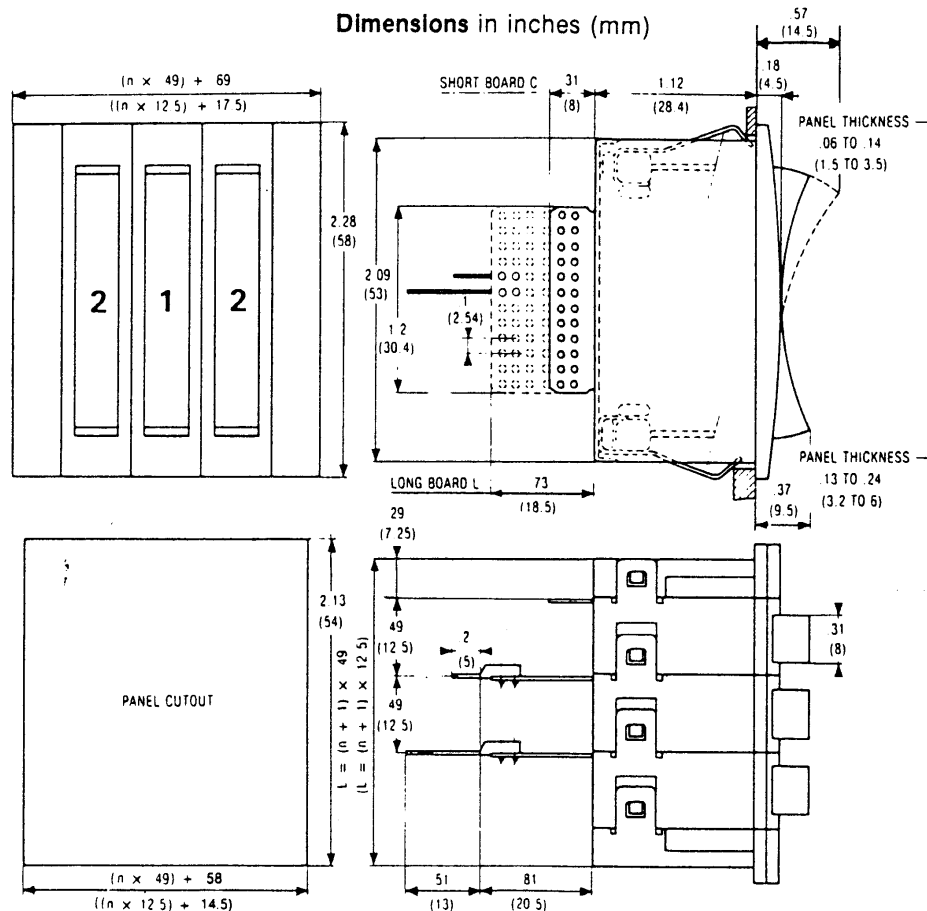

Rocker Switch - standard - rear mount Series 84 213

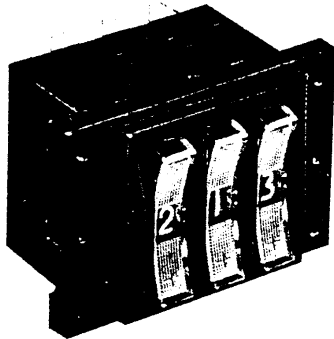

- Fast switching in both directions
- Large numerals — .18 in. (4.5 mm) high
- All modules easily assembled without hardware
- Good looking—easy to read
- Black or red wheels in stock — other colors on request

Mechanical & Electrical Specifications

Operating Voltage: .1 to 250 V AC
.1 to 50 V DC

Nominal Electrical Load (Resistive Load):
1 mA to 100 mA

Maximum Non-Switching Load: 1 A

Contact Resistance: 70 mΩ max.

Life at 50 V DC, .1 A, Resistive Load: 1 million operations

Note: For voltages and currents less than the above values, please consult us.

Dielectric Strength: 600 V

Operating Temperatures: —13° F. to 158° F.
(—25° C. to 70° C.)

Storage Temperatures: —40° F. to 185° F.
(—40° C. to 85° C.)

Dial Character Dimensions: .18 in. x .11 in.
(4.5 mm x 2.8 mm)

Operating Force at End of Rocker: 17 oz.
(500 g)

Materials

Case: Noryl

Wheel: Delrin

Rocker Actuator: Makrolon®
(Polycarbonate)

Contacts and Tracks: Copper—Nickel—Gold

Brush: Beryllium bronze

Printed Circuit Board: Glass-filled epoxy
(P.C. 75)

*Special elements not used in other manufacturers' products.

Dimensions in inches (mm)

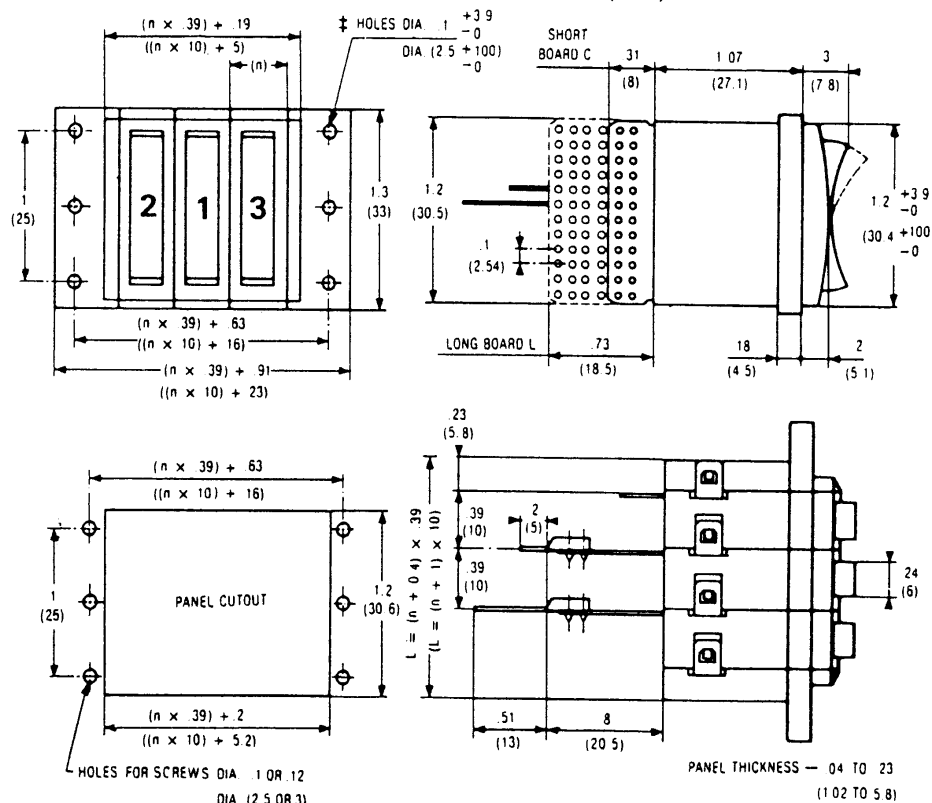

‡Note: Mounting by screws and nuts .09 in. (2.5 mm) dia. or self-tapping screws .11 in. (3 mm) dia.

Truth Tables - Series 84 210 - 84 211 - 84 212 - 84 213 - 84 214 - 84 218

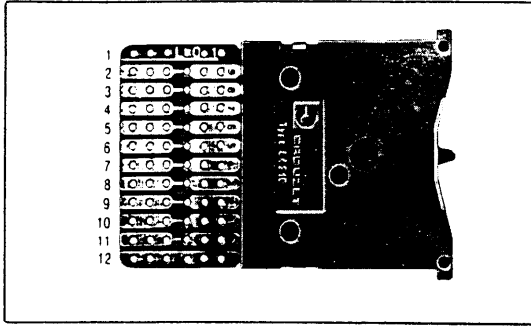

This photograph shows the numbering of each terminal for location purposes only.

The dots indicate the inter-connected tracks for each of the dial settings.

Decimal M01—M13—M14 (see note)

		C	0	1	2	3	4	5	6	7	8	9
Location on PC Board		12	11	10	9	8	7	6	5	4	3	2
Dial Setting	0	•	•									
	1	•		•								
	2	•			•							
	3	•				•						
	4	•					•					
	5	•						•				
	6	•							•			
	7	•								•		
	8	•									•	
	9	•										•

B.C.D.—M02

		C	1	2	4	8
Location on PC Board		9	8	7	6	5
Dial Setting	0	•				
	1	•	•			
	2	•		•		
	3	•	•	•		
	4	•			•	
	5	•	•		•	
	6	•		•	•	
	7	•	•	•	•	
	8	•				•
	9	•	•			•

B.C.D. + Complement—M03

		C	1	2	4	8	$\bar{1}$	$\bar{2}$	$\bar{4}$	$\bar{8}$
Location on PC Board		7	6	5	4	3	11	10	9	8
Dial Setting	0	•					•	•	•	•
	1	•	•					•	•	•
	2	•		•				•		•
	3	•	•	•					•	•
	4	•			•			•	•	
	5	•	•		•				•	•
	6	•		•	•			•		•
	7	•	•	•	•				•	•
	8	•				•	•	•	•	
	9	•	•			•		•	•	•

2 Position Repeating—M04

Type of Track		C	1	2
Location on PC Board		2	9	8
Dial Setting (To be specified)	+ 5	•	•	
	- 0	•	•	
	+ 5	•	•	
	- 0	•	•	
	+ 5	•	•	
	- 0	•	•	
	+ 5	•	•	
	- 0	•	•	
	+ 5	•	•	
	- 0	•	•	

B.C.D. Complement—M07

Type of Track		C	$\bar{1}$	$\bar{2}$	$\bar{4}$	$\bar{8}$
Location on PC Board		3	4	11	2	10
Dial Setting	0	•	•	•	•	•
	1	•		•	•	•
	2	•			•	•
	3	•				•
	4	•	•	•	•	•
	5	•		•		•
	6	•	•			•
	7	•		•		•
	8	•	•	•	•	•
	9	•		•		•

B.C.D. EXCESS 6 + Complement—M08

Type of Track		C	1	2	4	8	$\bar{1}$	$\bar{2}$	$\bar{4}$	$\bar{8}$
Location on PC Board		7	6	5	4	3	11	10	9	8
Dial Setting	0	•		•	•		•			•
	1	•	•	•	•					•
	2	•				•	•	•	•	
	3	•	•				•	•	•	
	4	•		•				•	•	
	5	•	•				•		•	
	6	•		•	•	•	•			
	7	•	•				•		•	
	8	•		•	•	•	•			
	9	•	•	•	•	•				

Hexadecimal B.C.D. - M 29*

		C	1	2	4
Location on PC Board		7	11	9	2
Dial Setting	0	•			
	1	•	•		
	2	•		•	
	3	•	•	•	
	4	•			•
	5	•	•	•	•
	6	•		•	•
	7	•	•	•	•
	8	•			
	9	•	•		
	10	•		•	
	11	•	•	•	
	12	•			•
	13	•	•	•	•
	14	•		•	•
	15	•	•	•	•

Note: In decimal and BCD the following alternatives are available.*

	Short Board	Long Board for Mounting of Resistors or Diodes	
		In Series on Each Track (Interrupted Tracks)	In Parallel from Track to Track (Non-Interrupted Tracks)
Break Before Make	MO 1-C (Decimal) MO 2-C (BCD)	MO 1-L (Decimal) MO 2-L (BCD)	M 14-L (Decimal) M 15-L (BCD Complement)
Make Before Break (on Request)	M 13-C (Decimal)	M 13-L (Decimal)	

*84 210 only

*Please consult us for special codes.

Push Button - miniature - panel mount Series 84 230

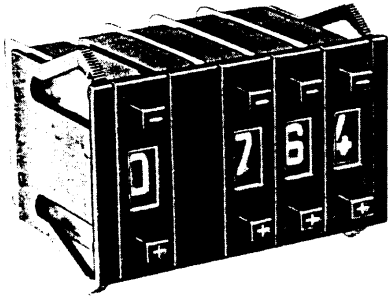

- Long circuit boards have track interruption to allow series mounting of components
- All modules easily assembled without hardware
- Black wheel standard – white wheel with black marking on request
- Fast, smooth switching action

Mechanical & Electrical Specifications

Max. operating voltage:
switched 50 VAC
unswitched 120 VAC

Rated amperage: switched 1-50mA

Max. amperage: unswitched 500mA

Min. contact resistance: .1 ohm

Min. insulation resistance: 100,000 megohms

Dielectric strength:
between tracks: 500 VAC
between tracks and ground: 2,500 VAC

Operating temperature:
+ 15°F to + 160°F (-10°C to + 70°C)

Storage temperature:
-40°F to + 185°F (-40°C to + 85°C)

Mechanical life:
500,000 operations

Materials

Case and wheel: polycarbonate
Push Buttons and thumbwheel: Delrin
Printed circuit board: epoxy glass
Printed contact: gold deposit
Contacts: tin plated

Panel cutout and front face dimensions in inches (mm)

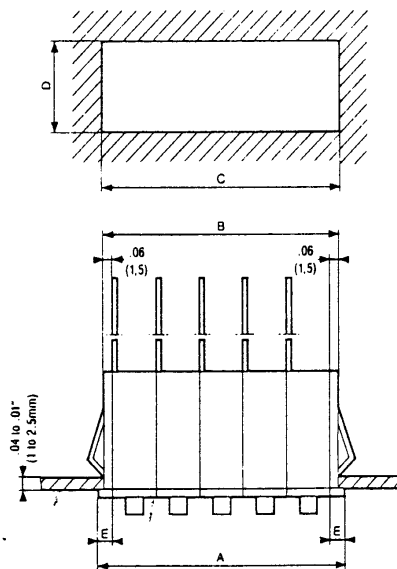

Dimensions in inches (mm)

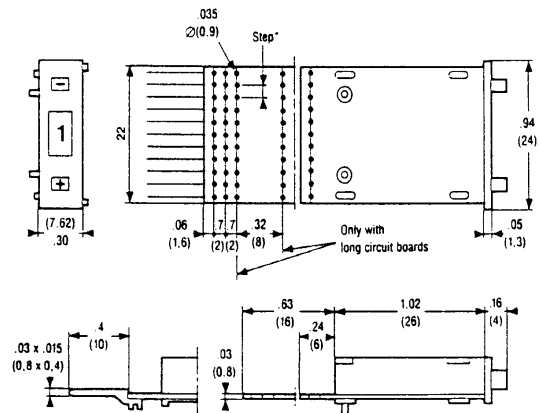

*Step: .08 (2) – M01, M03, M04, M30
Step: .1 (2.54) – M29 – M31
Step: .2 (5.08) – M02 – M07

Series 84 230

A (.30 x n) + .24 inches	(7.62 x n) + 6mm
B (.30 x n) + .12 inches	(7.62 x n) + 3mm
C (.30 x n) + .14 inches	(7.62 x n) + 3.5mm
D .89 inches	22.5mm
E .12 inches	3mm

Push Button - subminiature - panel mount Series 84 231

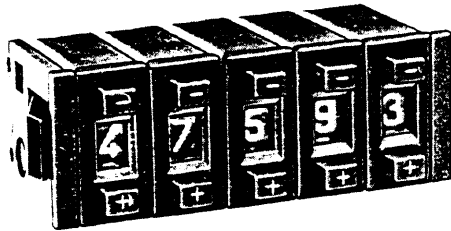

- Subminiature size – only .59 inch high
- All modules easily assembled without hardware
- Black wheel standard – white wheel with black markings on request
- Fast, smooth switching action

Mechanical & Electrical Specifications

Max. operating voltage:
switched 50 VAC
unswitched 120 VAC

Rated amperage: switched 1-50mA

Max. amperage: unswitched 500mA

Min. contact resistance: .1 ohm

Min. insulation resistance: 1,000 megohms

Dielectric strength:
between tracks: 500 VAC
between tracks and ground: 2,500 VAC

Operating temperature:
+ 15°F to + 160°F (-10°C to + 70°C)

Storage temperature:
-40°F to + 185°F (-40°C to + 85°C)

Mechanical life:
500,000 operations

Materials

Case and wheel: polycarbonate
Push Buttons and thumbwheel: Delrin
Printed circuit board: epoxy glass
Printed contact: gold deposit
Contacts: tin plated

Panel cutout and front face dimensions in inches (mm)

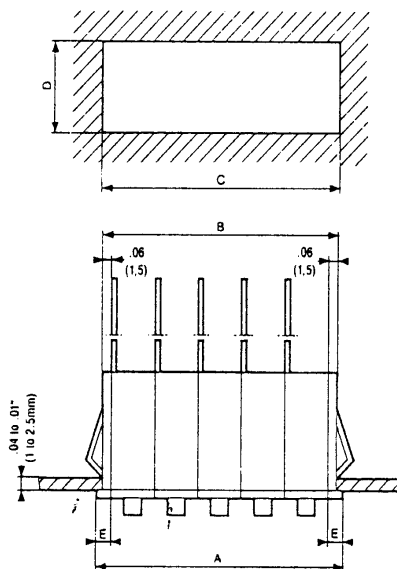

Dimensions in inches (mm)

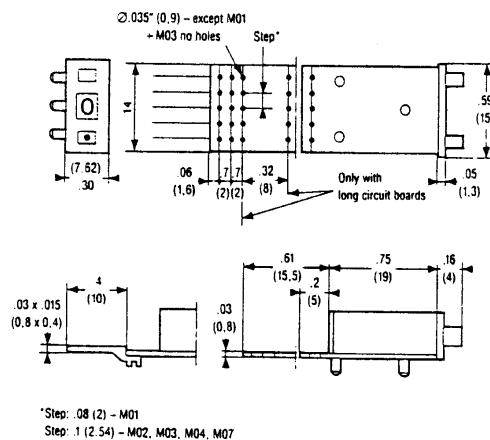

Series 84 231

A (.30 x n) + .20 inches	(7.62 x n) + 5.08mm
B (.30 x n) + .12 inches	(7.62 x n) + 3mm
C (.30 x n) + .14 inches	(7.62 x n) + 3.5mm
D .57 inches	14.5mm
E .10 inches	2.54mm

Digital Switches

Thumbwheel - flat PCB mount Series 84 235

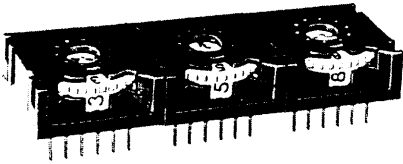

- Low profile – specially designed for PCB mounting
- All modules easily assembled without hardware
- Black or red wheels standard – white wheel with black marking on request
- Fast, smooth switching action

Mechanical & Electrical Specifications

Max. operating voltage:

36 VDC/150 VAC

Rated amperage: switched 1-100mA

Max. amperage: unswitched 500mA

Min. contact resistance: .1 ohm

Min. insulation resistance: 1,000 megohms

Dielectric strength:

between tracks: 500 VAC

between tracks and ground: 2,500 VAC

Operating temperature:

+ 15°F to + 160°F (–10°C to + 70°C)

Storage temperature:

–40°F to + 185°F (–40°C to + 85°C)

Mechanical life:

250,000 operations

Materials

Case and wheel: polycarbonate

Thumbwheel: Delrin

Printed circuit board: epoxy glass

Printed contact: gold deposit

Contacts: tin plated

Dimensions in inches (mm)

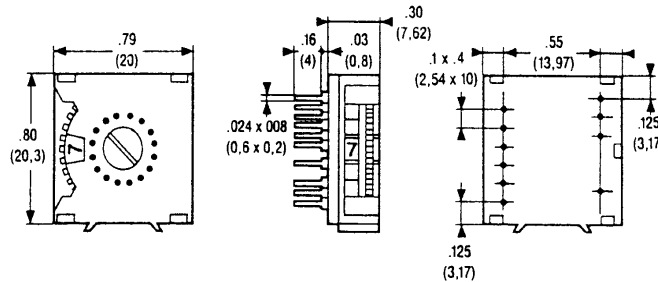

Truth Tables - Series 84 230, 84 231, and 84 235

The dots indicate the inter-connected tracks for each of the dial settings.

		B.C.D.				
		M02				
		C	1	2	4	8
Location on PC Board	84 230	10	2	4	6	8
	84 231	5	1	2	3	4
	84 235	7	12	10	8	4
Dial Setting	0	•				
	1	•	•			
	2	•		•		
	3	•	•	•		
	4	•			•	
	5	•	•		•	
	6	•		•	•	
	7	•	•	•	•	
	8	•				•
	9	•	•			•

		B.C.D. + Complement								
		M03								
		C	1	2	4	8	1	2	4	8
Location on PC Board	84 230	10	2	4	6	8	3	5	7	9
	84 231	5	10	9	8	7	1	2	3	4
	84 235	2	8	12	11	3	5	1	9	4
		6	10							
Dial Setting	0	•					•	•	•	•
	1	•	•				•	•	•	•
	2	•		•			•	•	•	•
	3	•	•				•	•	•	•
	4	•		•			•	•	•	•
	5	•	•				•	•	•	•
	6	•		•			•	•	•	•
	7	•	•				•	•	•	•
	8	•		•			•	•	•	•
	9	•	•				•	•	•	•

		B.C.D. Complement				
		M07				
		C	1	2	4	8
Location on PC Board	84 230	4	2	6	8	10
	84 231	5	1	2	3	4
	84 235	8	12	10	4	2
		7	6			
Dial Setting	0	•	•	•	•	•
	1	•	•	•	•	•
	2	•	•	•	•	•
	3	•	•	•	•	•
	4	•	•	•	•	•
	5	•	•	•	•	•
	6	•	•	•	•	•
	7	•	•	•	•	•
	8	•	•	•	•	•
	9	•	•	•	•	•

		2 Position Repeating		
		M04		
		C	1	2
Location on PC Board	84 230	1	2	11
	84 231	2	3	4
	84 235	7	4	8
Dial Settings (To be specified)	+	5	•	•
	-	0	•	•
	+	5	•	•
	-	0	•	•
	+	5	•	•
	-	0	•	•
	+	5	•	•
	-	0	•	•
	+	5	•	•
	-	0	•	•

		Hexadecimal B.C.D.				
		M29				
		C	1	2	4	8
Location on PC Board	84 230	5	4	7	6	8
	84 235	8	12	2	10	4
		7				
Dial Setting	0	•				
	1	•	•			
	2	•		•		
	3	•	•	•		
	4	•			•	
	5	•	•		•	
	6	•		•	•	
	7	•	•	•	•	
	8	•				•
	9	•	•			•
	A	•		•	•	
	B	•	•	•	•	
	C	•			•	•
	D	•	•	•	•	
	E	•		•	•	•
	F	•	•	•	•	

		Hexadecimal B.C.D. + Complement								
		M30								
		C	1	2	4	8	1	2	4	8
Location on PC Board	84 230	10	3	5	9	7	4	2	8	6
	84 231	4	10	11	12	8	3	2	1	5
	84 235	6								
Dial Setting	0	•					•	•	•	•
	1	•	•				•	•	•	•
	2	•		•			•	•	•	•
	3	•	•				•	•	•	•
	4	•		•			•	•	•	•
	5	•	•				•	•	•	•
	6	•		•			•	•	•	•
	7	•	•				•	•	•	•
	8	•		•			•	•	•	•
	9	•	•				•	•	•	•
	A	•		•			•	•	•	•
	B	•	•				•	•	•	•
	C	•		•			•	•	•	•
	D	•	•				•	•	•	•
	E	•		•			•	•	•	•
	F	•	•				•	•	•	•

		Hexadecimal B.C.D. Complement Only				
		M31				
		C	1	2	4	8
Location on PC Board	84 230	8	4	6	7	5
	84 231	8	12	10	4	7
	84 235	7				
Dial Setting	0	•	•	•	•	•
	1	•	•	•	•	•
	2	•	•	•	•	•
	3	•	•	•	•	•
	4	•	•	•	•	•
	5	•	•	•	•	•
	6	•	•	•	•	•
	7	•	•	•	•	•
	8	•	•	•	•	•
	9	•	•	•	•	•

		Decimal										
		M01										
		C	0	1	2	3	4	5	6	7	8	9
Location on PC Board	84 230	1	11	2	3	4	5	6	7	8	9	10
	84 231	9	6	1	11	2	10	3	8	4	7	5
	84 235	7	5	12	11	10	9	8	1	2	3	4
Dial Setting	0	•	•									
	1	•		•								
	2	•			•							
	3	•				•						
	4	•					•					
	5	•						•				
	6	•							•			
	7	•								•		
	8	•									•	
	9	•										•

Terminal Configuration

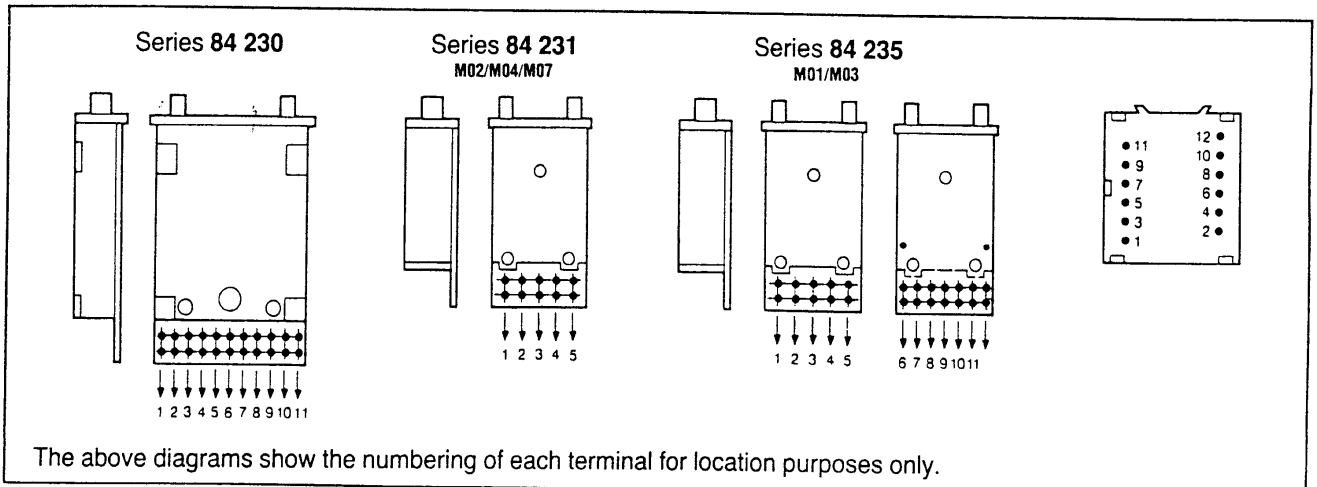

How to Order

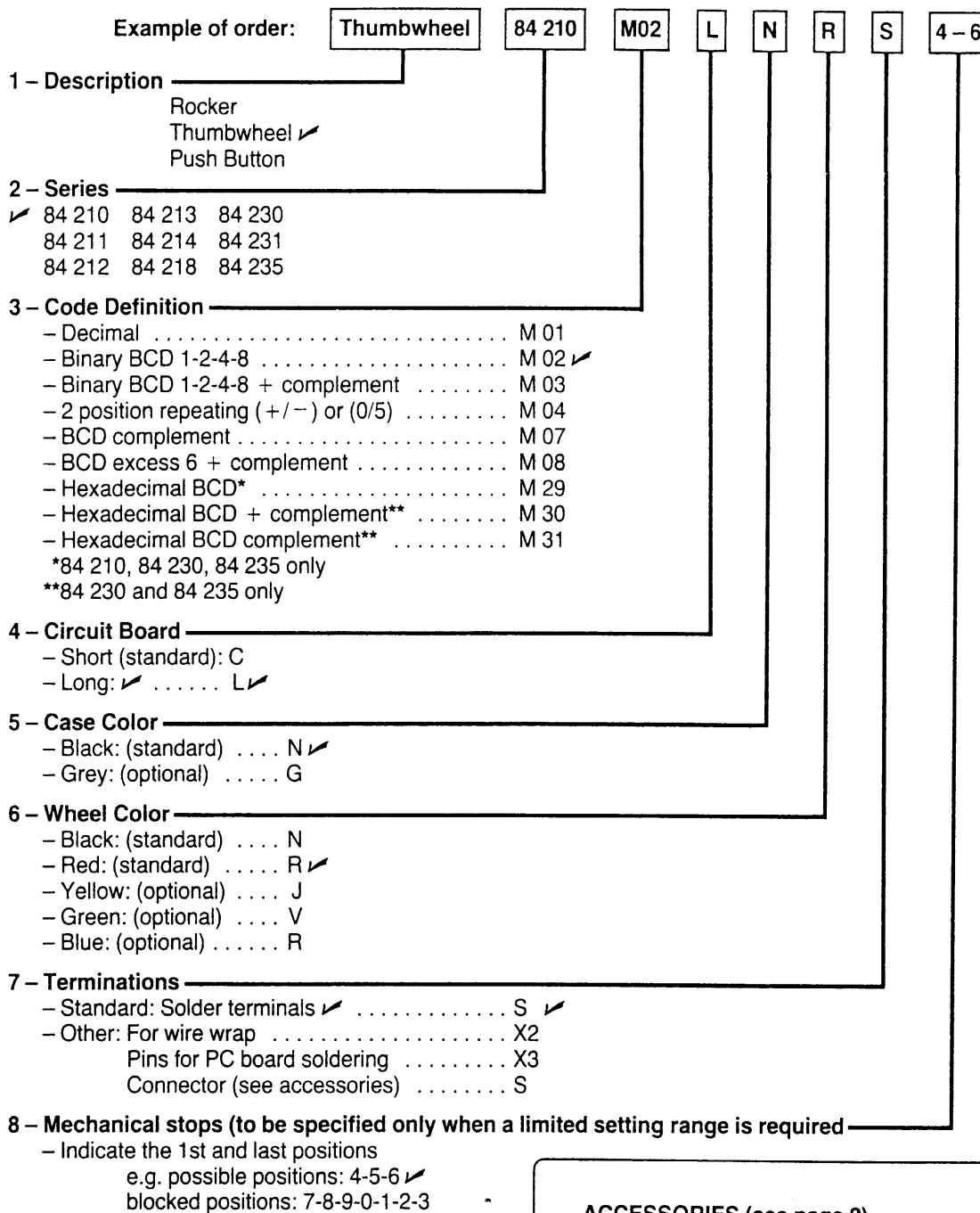

Above example to be read as:

- 1 - Thumbwheel switch
- 2 - 84 210
- 3 - binary BCD 1-2-4-8 - M 02
- 4 - Long circuit board
- 5 - Black case
- 6 - Red wheel
- 7 - Standard solder terminals
- 8 - Possible positions 4-5-6

ACCESSORIES (see page 2)
 (specify digital switch series number)

- **Pair of End Caps including Clips.** JE/
 (color: N - black: standard G - grey: optional)
- **Spacer:** MI
- **Encoded "Dummy" Module:** MC - also specify code, circuit board, color connections
- **Separator including Clips:** MS
- **Connector for Plugging of Circuit C:**
 CR/W2-Solder Terminals
 CR/X2-Wire Wrapping Terminals
 CR/X3-PC Board Pins

Crouzet® Digital Switches

L.E.D. Readouts - 3 main families

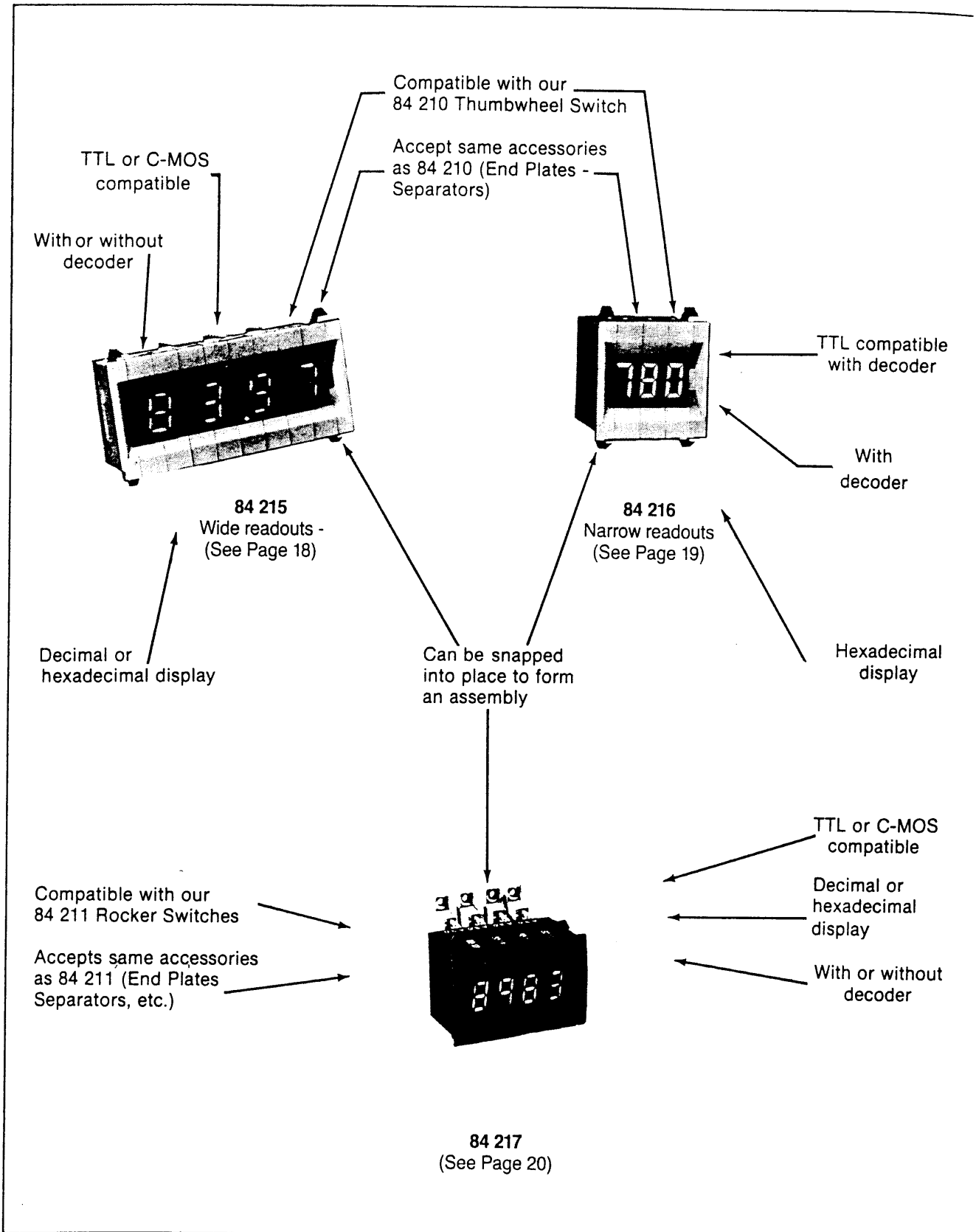

L.E.D. Readouts - wide readout - panel mount Series 84 215

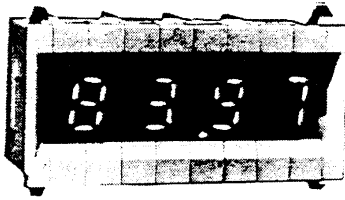

- The L.E.D. readout modules type 84 215 can work alongside our Thumbwheel switches, 84 210 Series.
- The same accessories (end plates, separators, etc.) can be used. This allows the assembly of counting and programming systems, offering a consistent design in a small size.
- As with our Thumbwheel switches, these modules can be snapped into place to form an assembly.
- Choice of decoders (TTL or C-MOS), memory, voltages.
- Three versions are available.

Common Specifications

Figure Height: .433 in. (11 mm)	Current Per Segment: 7 mA
Module Width: .62 in. (16 mm)	Display: H.P. 5082 - 7653
Color: Red	RBI - RBO output on all modules
Operating Temperature: +32° F to +140° F. (0° C. to 60° C.)	(except A1)
Case Color: Black (standard) or grey (upon request)	Common Cathode

Particular Specifications

Code	BCD Decoder		LT Output (Lamp Test)	EL Output (Memory)	Position of Decimal Point		Typical Consumption of Decoder at 75° F (25° C)	Voltages Available	Type of Display
	C-MOS	TTL			Left	Right			
A1	No	No	Yes	No		•	N.A.	5 V (standard) 12-15-24 V (on request)	According to User's decoder
A3	MM74 C48	No	Yes	No		•	0.05 μ A	5 V (standard) 12-15 V (on request)	Decimal
A6	No	9368	No	Yes		•	45 mA	5 V	Hexadecimal

Terminations

Dimensions in inches (mm)

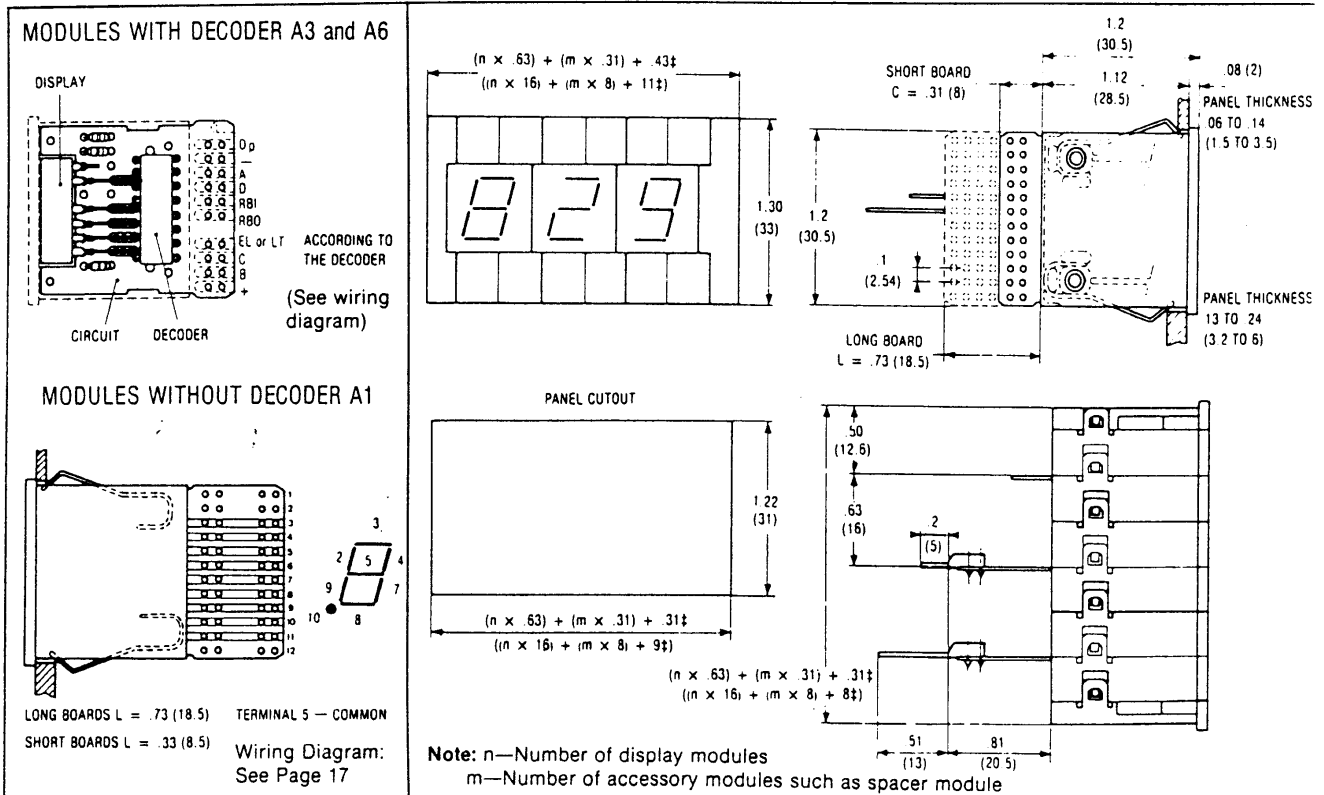

L.E.D. Readouts - Wiring Diagrams

84 215 - A3

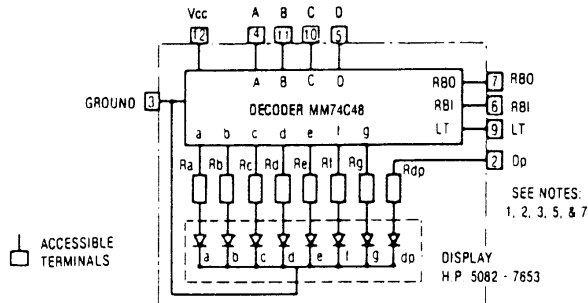

84 215 - A6

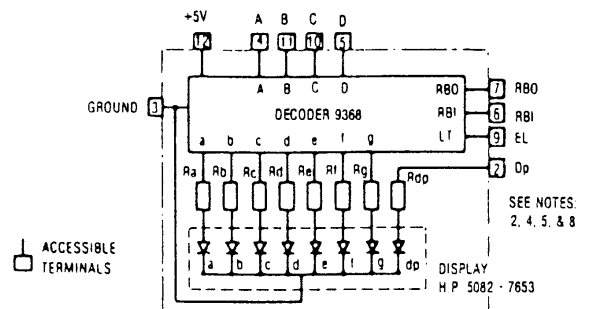

84 216

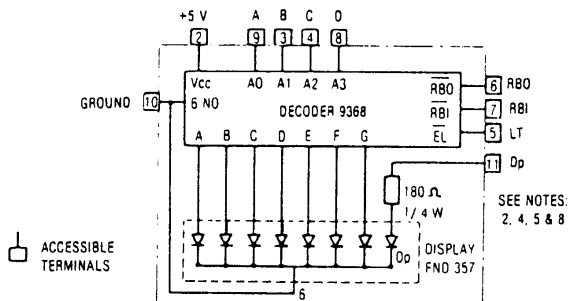

84 217 - A3

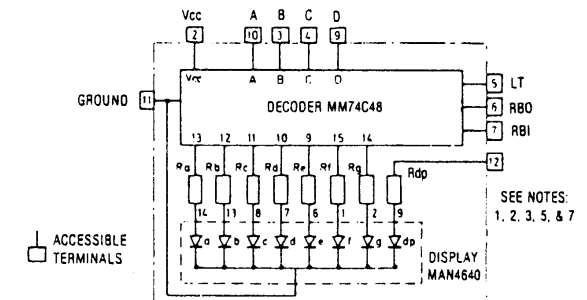

84 217 - A6

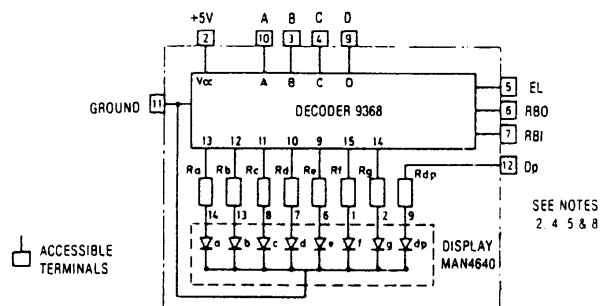

84 217 - A8

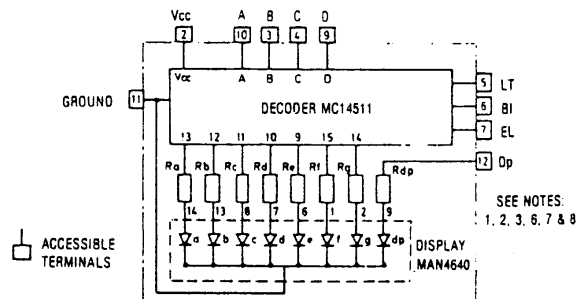

84 217 - A10

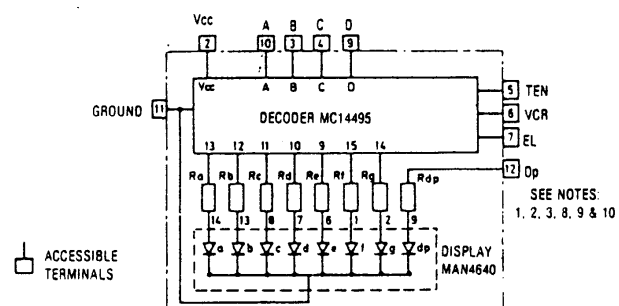

84 217 - A11

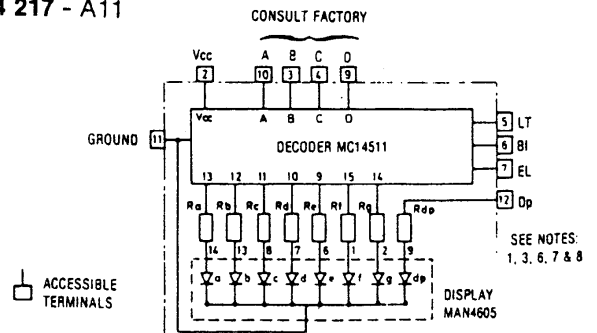

L.E.D. Readouts - Wiring Diagrams

Notes:

1. Vcc = 5, 12, 15 or 24 V according to the model (5 V standard - 12, 15 and 24 V on request).
2. A, B, C and D correspond respectively to 1, 2, 4 and 8 of BCD code.
3. In all C-MOS decoders, it is mandatory that all inputs be connected at ALL times either to the + or the ground (except RBI-RBO - see note 5). The use of bias resistors is therefore necessary (see diagram). Should an input not be used at all, it may be directly connected either to the + or the ground (depending on the function).
4. For TTL decoders, should an input not be connected to either the + or the ground, the decoder might not work properly (while not connected), but it would not be destroyed.
5. The non-significant zeros are cancelled when RBI (Ripple Blanking Input) is connected to the ground, if several modules are connected together the RBI of the module adjacent to the module of the units (eg: ten or tenth) must be connected to the RBO (Ripple Blanking Output) of the next unit (hundred or hundredth) etc. The first RBO's (ten and tenth) as well as the unit's are left unconnected. (the zero of the unit is never cancelled).

If the zero cancellation is not required, the RBI inputs must be connected to the + of the power supply and RBO must be left unconnected.

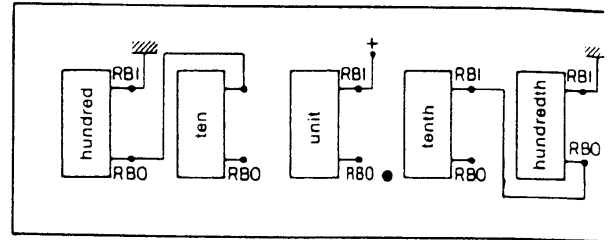

6. Connecting BI (Blanking Input) to the ground cancels the display (otherwise connect BI to + of supply).
7. Connecting LT (Lamp Test) input to ground makes possible to control all segments (otherwise connect to + of supply).
8. Connecting EL (Enable Latch) to + of supply keeps display in memory. Otherwise connect EL to ground.
9. TEN output is in state "0" when digits from 0 to 9 displayed and in state "1" when digits from A to F displayed.
10. VCR output is open for displays from 0 to E. When displayed the state is "0".

Example of Control of a Readout Module with a Thumbwheel Switch.

