



MICRO SWITCH

FREEPORT, ILLINOIS, U.S.A.
A DIVISION OF HONEYWELL

FED. MFG. CODE 91929

PACKET

CATALOG LISTING

6PA69

6PA69

M

DRAWING NUMBER

5

ISSUE

REVISIONS

REVISIONS

A CO18785

OMW

7 FEB 64

B CO60129

TSK

9 MAR 89

REPLACES

RELEASE NO.

CHECK

CHECK

11 FEB 64

DAW

CHECK

64

7 FEB 64

DRAWN

OMW

FO-50378

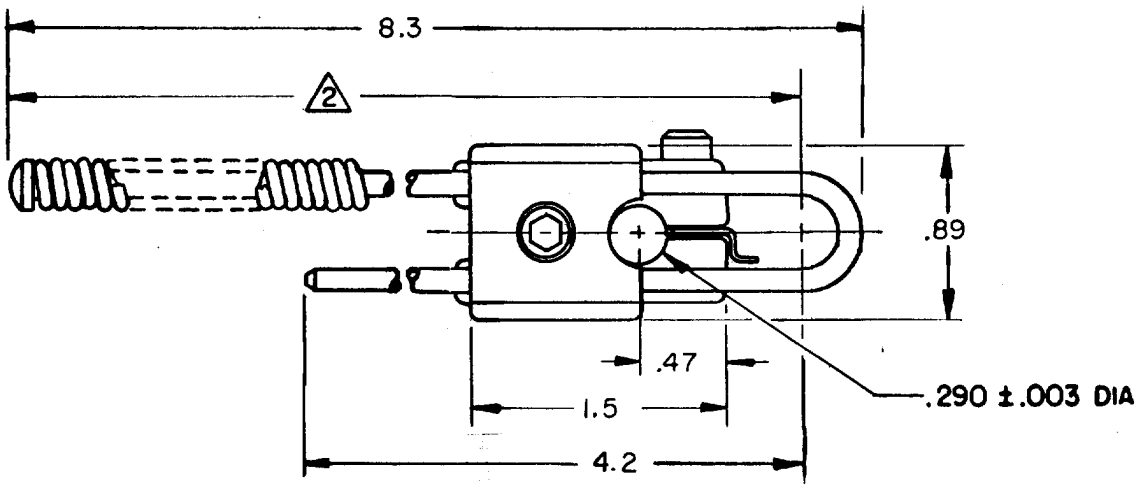
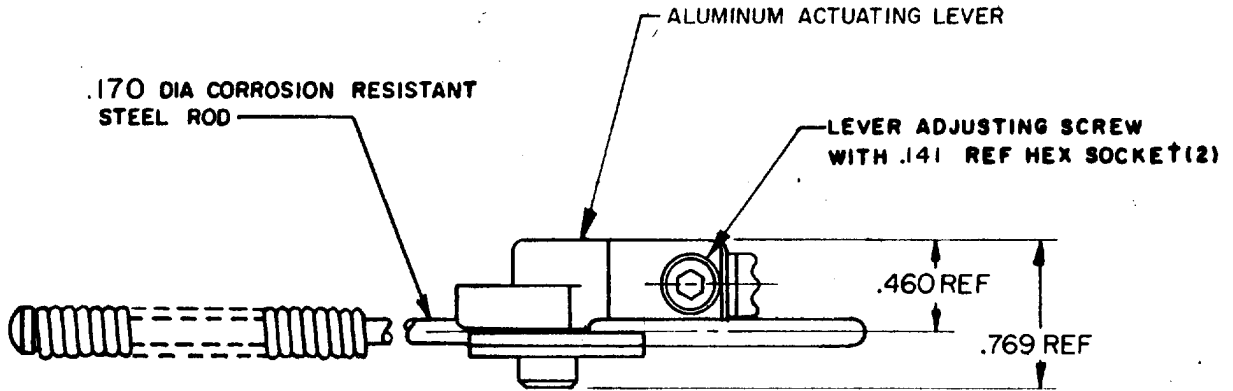

NOTE -
 △ - PARTS FURNISHED ASSEMBLED
 △ 2 - LEVER LENGTH ADJUSTABLE FROM 5.02 TO 7.47

THIS DRAWING COVERS A PROPRIETARY ITEM AND IS THE PROPERTY OF MICRO SWITCH, A DIVISION OF MINNEAPOLIS-HONEYWELL REGULATOR CO. THIS DRAWING IS NOT TO BE COPIED OR USED WITHOUT THE APPROVAL OF MICRO SWITCH.

CHARACTERISTICS	ELECTRICAL DATA	SCALE FULL
	CONTACT ARRANGEMENT	DO NOT SCALE PRINT
		UNLESS OTHERWISE NOTED
		DIMENSIONS ARE IN INCHES
		TOLERANCES ARE:
		ONE PLACE (.0) ± .030
		TWO PLACE (.00) ± .015
		THREE PLACE (.000) ± .005
		ANGLES ±
		WEIGHT