

Solid State Relays Industrial, 3-Phase ZS Type RZ3A



- 3-phase Solid State Relay
- Zero switching
- Rated operational current: 3 x 25, 40, 55 or 75 A
- Rated operational voltage: Up to 600 VAC
- Control voltage 5 VDC, 4-32 VDC or 20-275 VAC/DC
- Integral snubber networks
- Over-temperature protection option with alarm output
- IP 10 back-of-hand protection
- LED indication of control input and over-temperature alarm status

Product Description

A Solid State Relay family designed to switch various loads such as heating elements, motors and transformers. The relay is capable of switching high voltages up to 600 VACrms.

For higher reliability and load cycle capability three semiconductor power units are soldered directly on to the direct copper bonded (DCB) substrate.

AC- or DC-controlled versions are available. Built-in LED status indication for applied control voltage and over-temperature alarm (optional). A version that can be controlled with 5 VDC @ 15 mA (max) is also available (LD).

The series covers a range of load currents up to 75 AACrms.

Ordering Key

RZ 3 A 60 D 75 P

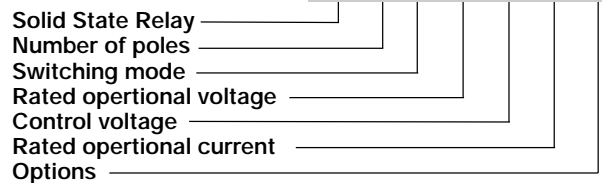

Type Selection

Switching mode	Rated operational voltage	Rated operational current	Control voltage	Option
A: Zero Switching	40: 400 VACrms 60: 600 VACrms	25: 25 AACrms 40: 40 AACrms 55: 55 AACrms 75: 75 AACrms	LD: 5 VDC D: 4-32 VDC A: 24-275 VAC/24-50 VDC	P: Over-temperature protection and alarm output (available only for A and D input)

Selection Guide

Rated operational voltage	Control voltage	Rated operational current			
		25 A	40 A	55 A	75 A
400 VACrms	5 VDC	RZ3A40LD25	RZ3A40LD40	RZ3A40LD55	RZ3A40LD75
	4-32 VDC	RZ3A40D25	RZ3A40D40	RZ3A40D55	RZ3A40D75
	24-275 VAC/24-50 VDC	RZ3A40A25	RZ3A40A40	RZ3A40A55	RZ3A40A75
600 VACrms	5 VDC	RZ3A60LD25	RZ3A60LD40	RZ3A60LD55	RZ3A60LD75
	4-32 VDC	RZ3A60D25	RZ3A60D40	RZ3A60D55	RZ3A60D75
	24-275 VAC/24-50 VDC	RZ3A60A25	RZ3A60A40	RZ3A60A55	RZ3A60A75

Options

Protection: Over-temperature protection and alarm output: add suffix P to include over-temperature protection and alarm output. Example: RZ3A60D75P

General Specifications

	RZ3A40..	RZ3A60..
Operational voltage ranges	24-440 VAC	42-660 VAC
Non-rep. peak voltage	850 V _p	1200 V _p
Operational frequency range	45 to 65 Hz	45 to 65 Hz
Overvoltage category	III	III
Pollution degree	3	2
Approvals*	UL, CSA	UL, CSA
CE-marking	Yes	Yes

*Approvals pending

Input Specifications

	RZ3A..LD..	RZ3A..D..	RZ3A..A..
Control voltage range	5 VDC	4-32 VDC	24-50 VDC/24-275VAC
Pick-up voltage	4.5 VDC	3.8 VDC	18 VAC/20 VDC
Drop-out voltage	1.2 VDC	1.2 VDC	9 VAC
Input current	≤ 15 mA	≤ 23 mA	≤ 15 mA
Response time pick-up Power output = 50 Hz	10 ms	10 ms	20 ms
Response time drop-out Power output = 50 Hz	10 ms	10 ms	30 ms

All data at 25°C

Output Specifications

	RZ3A..25..	RZ3A..40..	RZ3A..55..	RZ3A..75..
Rated operational current AC51 @ Ta=25°C AC53a @ Ta=25°C	25 Arms 5 Arms	40 Arms 8 Arms	55 Arms 15 Arms	75 Arms 20 Arms
Minimum operational current	150 mArms	150 mArms	150 mArms	150 mArms
Rep. overload current t=1 s	37 Arms	60 Arms	< 125 Arms	< 150 Arms
Non-rep. surge current t = 10 ms	230 A _p	300 A _p	600 A _p	1000 A _p
Off-state leakage current	< 3 mArms	< 3 mArms	< 3 mArms	< 3 mArms
I ² t for fusing t = 10 ms	265 A ² s	450 A ² s	1800 A ² s	6600 A ² s
Critical di/dt @ 50 Hz	≥ 100 A/μs	≥ 100 A/μs	≥ 100 A/μs	≥ 100 A/μs
On-state voltage drop	≤ 1.6 Vrms	≤ 1.6 Vrms	≤ 1.6 Vrms	≤ 1.6 Vrms
Critical dV/dt off-state	≥ 500 V/μs	≥ 500 V/μs	≥ 500 V/μs	≥ 500 V/μs

Alarm Output Specifications

Collector - emitter voltage	35 Vdc
Emitter - collector voltage	6 Vdc
Collector current	50 mA
Delay time on reset	20 mS

Thermal Specifications

Operating temperature	-30° to +80°C (-22° to +158° F)
Storage temperature	-40° to +100°C (-40° to + 212° F)
Junction temperature	≤ +125°C (+ 257° F)

Insulation

Rated insulation voltage	
Input to output	≥ 4000 VACrms
Output to case	≥ 4000 VACrms



Heatsink Dimensions (load current versus ambient temperature)

RZ ..25

Load current [A]	Thermal resistance [K/W]							Power dissipation [W]
	20	30	40	50	60	70	80	
25.0	0.44	0.34	0.23	0.12	0.01	--	--	92
22.5	0.62	0.49	0.37	0.24	0.12	--	--	80
20.0	0.84	0.69	0.54	0.40	0.25	0.10	--	68
17.5	1.12	0.95	0.78	0.60	0.43	0.25	0.08	58
15.0	1.51	1.30	1.09	0.88	0.67	0.46	0.25	47
12.5	2.06	1.80	1.54	1.27	1.01	0.75	0.48	38
10.0	2.75	2.40	2.06	1.72	1.37	1.03	0.69	29
7.5	3.83	3.35	2.87	2.39	1.91	1.43	0.96	21
5.0	6.01	5.26	4.51	3.76	3.01	2.25	1.50	13
2.5	12.62	11.04	9.46	7.89	6.31	4.73	3.15	6

20 30 40 50 60 70 80 T_A
Ambient temp [°C]

RZ ..40

Load current [A]	Thermal resistance [K/W]							Power dissipation [W]
	20	30	40	50	60	70	80	
40.0	0.54	0.44	0.34	0.24	0.14	0.04	--	101
36.0	0.66	0.55	0.44	0.33	0.22	0.11	--	91
32.0	0.81	0.68	0.56	0.43	0.31	0.18	0.06	80
28.0	1.00	0.86	0.72	0.57	0.43	0.29	0.14	70
24.0	1.26	1.09	0.93	0.76	0.59	0.42	0.25	60
20.0	1.62	1.42	1.21	1.01	0.81	0.61	0.41	49
16.0	2.03	1.78	1.52	1.27	1.02	0.76	0.64	39
12.0	2.72	2.38	2.04	1.70	1.36	1.02	1.03	29
8.0	4.11	3.59	3.08	2.57	2.05	1.54	1.81	19
4.0	8.26	7.22	6.19	5.16	4.13	3.10	4.14	10

20 30 40 50 60 70 80 T_A
Ambient temp [°C]

RZ ..55

Load current [A]	Thermal resistance [K/W]							Power dissipation [W]
	20	30	40	50	60	70	80	
55.0	0.29	0.23	0.17	0.11	0.05	--	--	164
50.0	0.36	0.29	0.22	0.16	0.09	0.02	--	148
45.0	0.44	0.36	0.29	0.21	0.14	0.06	--	133
40.0	0.54	0.46	0.37	0.29	0.20	0.12	0.03	118
35.0	0.67	0.58	0.48	0.38	0.28	0.19	0.09	103
30.0	0.85	0.74	0.62	0.51	0.39	0.28	0.16	87
25.0	1.10	0.96	0.82	0.68	0.55	0.41	0.27	73
20.0	1.38	1.21	1.04	0.87	0.69	0.52	0.35	58
15.0	1.85	1.62	1.39	1.16	0.93	0.70	0.46	43
10.0	2.80	2.45	2.10	1.75	1.40	1.05	0.70	29
5.0	5.62	4.92	4.21	3.51	2.81	2.11	1.40	14
2.5	11.26	9.85	8.45	7.04	5.63	4.22	2.82	7

20 30 40 50 60 70 80 T_A
Ambient temp [°C]

RZ ..75

Load current [A]	Thermal resistance [K/W]							Power dissipation [W]
	20	30	40	50	60	70	80	
75.0	0.27	0.22	0.17	0.12	0.07	0.02	--	201
70.0	0.32	0.27	0.21	0.16	0.10	0.05	--	184
65.0	0.38	0.32	0.26	0.20	0.14	0.08	0.02	167
60.0	0.44	0.38	0.31	0.25	0.18	0.11	0.05	151
55.0	0.52	0.45	0.38	0.30	0.23	0.16	0.08	136
50.0	0.62	0.54	0.45	0.37	0.29	0.21	0.12	121
45.0	0.74	0.64	0.55	0.46	0.36	0.27	0.17	106
40.0	0.87	0.76	0.65	0.54	0.43	0.32	0.22	92
35.0	1.01	0.89	0.76	0.63	0.51	0.38	0.25	79
30.0	1.21	1.06	0.91	0.76	0.60	0.45	0.30	66
25.0	1.49	1.30	1.11	0.93	0.74	0.56	0.37	54
20.0	1.90	1.67	1.43	1.19	0.95	0.71	0.48	42
15.0	2.60	2.28	1.95	1.63	1.30	0.98	0.65	31
10.0	4.01	3.51	3.01	2.51	2.01	1.50	1.00	20
5.0	8.24	7.21	6.18	5.15	4.12	3.09	2.06	10

20 30 40 50 60 70 80 T_A
Ambient temp [°C]

Heatsink Selection

Carlo Gavazzi Heatsink (see Accessories)	Thermal resistance
No heatsink required	$R_{th\ s-a} > 8.0$ K/W
RHS 300 Assy or backplate	5.0 K/W
RHS 112 Assy	1.1 K/W
RHS 301 Assy	0.8 K/W
RHS 112 F Assy	0.4 K/W
RHS 301 F Assy	0.25 K/W
Consult your distributor	< 0.25 K/W

Functional Diagram

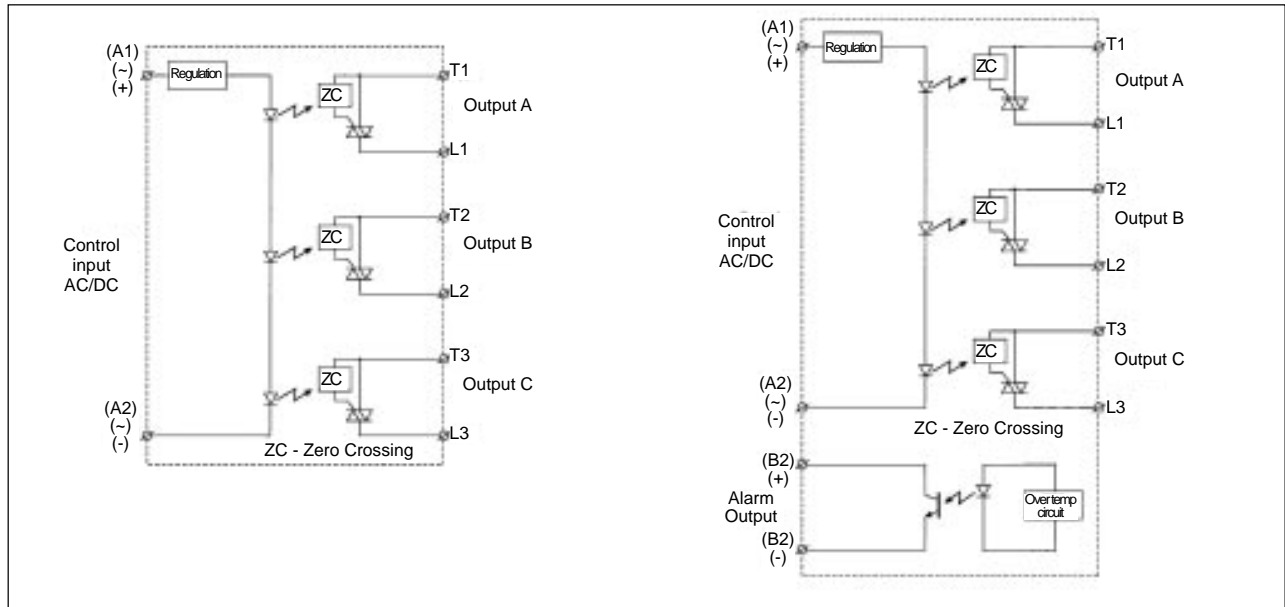

Housing Specifications

Weight	Approx. 380 g
Material	Noryl
Base plate	
25, 40, 55A	Aluminum, nickel-plated
75A	Copper, nickel-plated
Potting compound	Polyurethane
Relay	
Mounting screws	M5
Mounting torque	≤ 1.5 Nm
Control terminal	
Mounting screws	M3
Mounting torque	≤ 0.5 Nm
Wire size	Max. 2 x 2.5 mm ² Min. 2 x 1.0 mm ²
Power terminal	
Mounting screws	M5
Mounting torque	≤ 2.5 Nm 2 x 6 mm ² (AWG8)
Wire size	Max. 2 x 6 mm ² Min. 2 x 1 mm ²

Dimensions

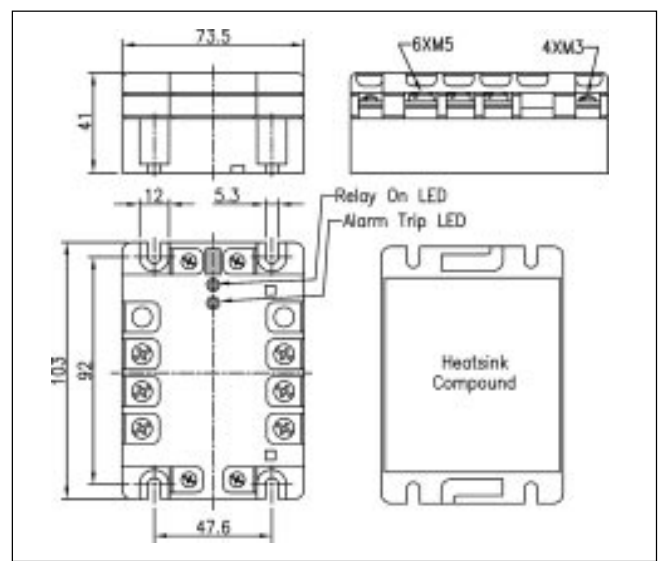

Alarm Output Connection

