

- Zero Voltage and Random Turn-On Switching
- Panel Mount
- 800V Transient Capability
- Internal Snubber

Featuring state-of-the-art Surface Mount Technology, these SPST-NO relays deliver proven reliability in the most demanding applications. Output consists of an SCR AC switch and is available in zero-cross, random turn-on (phase controllable) and versions with either AC or DC input (coil) control. Manufactured in Crydom's ISO 9001 Certified facility for optimum product performance and reliability.

MODEL NUMBERS	AC CONTROL	A4812	A4825	A4850	A4875	A4890
	DC CONTROL	D4812	D4825	D4850	D4875	D4890

OUTPUT SPECIFICATIONS ①

	A4812	A4825	A4850	A4875	A4890
Operating Voltage (47-63 Hz) [Vrms]	80-530	80-530	80-530	80-530	80-530
Max. Load Current ③ [Arms]	12	25	50	75	90
Min. Load Current, [mArms]	40	40	40	40	40
Transient Overvoltage [Vpk]	800	800	800	800	800
Max. Surge Current, (16.6ms) [Apk]	140	250	625	1000	1200
Max. On-State Voltage Drop @ Rated Current [Vpk]	1.7	1.7	1.7	1.7	1.7
Thermal Resistance Junction to Case (R _{θJC}) [°C/W]	1.48	1.02	0.63	0.31	0.28
Maximum I ² t for Fusing, (8.3 msec.) [A ² sec]	81	260	1620	4150	6000
Max. Off-State Leakage Current @ Rated Voltage [mArms]	10	10	10	10	10
Min. Off-State dv/dt @ Max. Rated Voltage [V/μsec] ②	500	500	500	500	500
Max. Turn-On Time ④	1/2 Cycle (DC Input), 10.0 msec (AC Input)				
Max. Turn-Off Time	1/2 Cycle (DC Input), 40.0 msec (AC Input)				
Power Factor (Min.) with Max. Load	0.5	0.5	0.5	0.5	0.5

INPUT SPECIFICATIONS ①

	DC CONTROL (D PREFIX)	AC CONTROL (A PREFIX)
Control Voltage Range	3-32 Vdc	90-280 Vrms (60Hz)
Max. Reverse Voltage	-32 Vdc	—
Max. Turn-On Voltage	3.0 Vdc	90 Vrms
Min. Turn-Off Voltage	1.0 Vdc	10 Vrms
Nominal Input Impedance	See Note ⑤	60K Ohms
Typical Input Current	2.0 mA ⑤	2mA @ 120 Vrms, 4mA @ 240 Vrms

GENERAL NOTES

© 2003 CRYDOM CORP, Specifications subject to change without notice.

- ① All parameters at 25°C unless otherwise specified.
- ② Off-State dv/dt test method per EIA/NARM standard RS-443, paragraph 13.11.1
- ③ Heat sinking required, for derating curves see page 2.
- ④ Turn-on time for random turn-on versions is 0.02 msec (DC Control Models).
- ⑤ Input circuitry incorporates active current limiter.

For recommended applications and more information contact:
USA: Sales Support (877) 502-5500 **Tech Support** (877) 702-7700 **FAX** (619) 710-8540
 Crydom Corp, 2320 Paseo de las Americas, Ste. 201, San Diego, CA 92154
Email: sales@crydom.com **WEB SITE:** http://www.crydom.com
UK: +44 (0)1202 365070 • **FAX** +44 (0)1202 365090 Crydom International Ltd., 7 Cobham Road, Ferndown Industrial Estate, Ferndown, Dorset BH21 7PE, **Email:** intsales@crydom.com.
GERMANY: +49 (0)180 3000 506



GENERAL SPECIFICATIONS

Dielectric Strength 50/60Hz Input/Output/Base	4000 Vrms
Insulation Resistance (Min.) @ 500 Vdc	10 ⁹ Ohm
Max. Capacitance Input/Output	8 pF
Ambient Operating Temperature Range	-40 to 80°C
Ambient Storage Temperature Range	-40 to 125°C

MECHANICAL SPECIFICATIONS

Weight: (typical)	3.0 oz. (86.5g)
Encapsulation:	Thermally Conductive Epoxy
Terminals:	Screws and Saddle Clamps Furnished, Unmounted

AVAILABLE OPTIONS

- 10** Random Turn-On (AC & DC Control)
Phase Controllable (DC Control)
Example: **D4890-10**
- F** Faston Terminals (Up to 25 Amp Models)
Example: **D4850F**
- H** Heat Transfer Pad (Attached)
Example: **D4850H**

Screw Torque Requirements:
6-32 Screws - 10 in. lbs.,
8-32 and 10-32 Screws - 20in. lbs.
(Screws dry without grease.)

Fastons:
Single pair (up to 25A)
Double pair* (up to 50A).
*Caution: User must connect to both pairs

Crydom Heat Sinks offer excellent thermal management and are perfectly matched to the load current ratings of Crydom panel mount relays. Request Crydom's Heat Sink specification sheet for all the details.

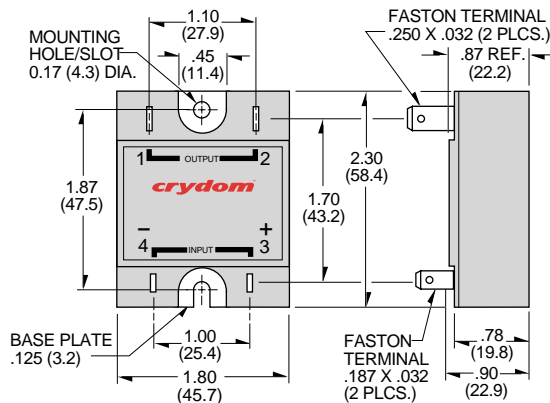
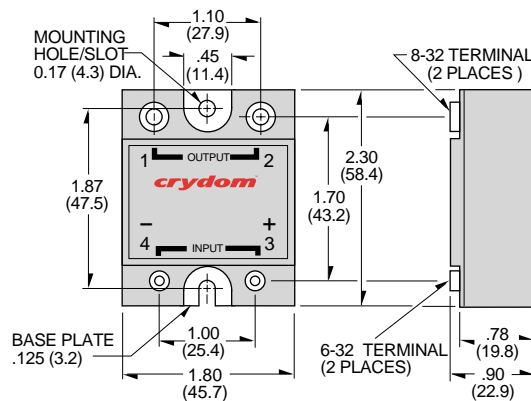

All dimensions are in inches (millimeters)

APPROVALS

UL E116949
CSA LR81689
VDE 10143 UG



CURRENT DERATING CURVES

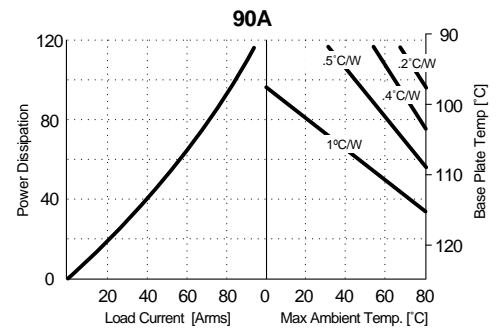
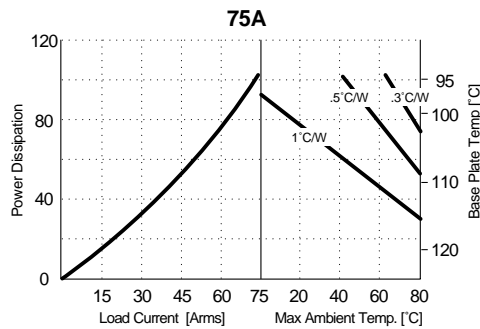
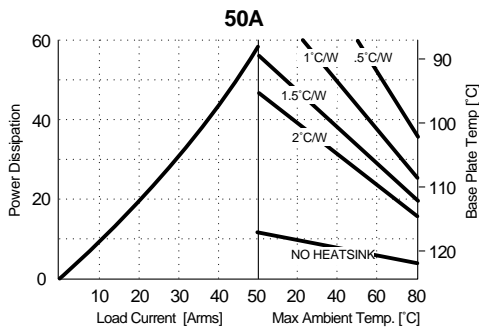
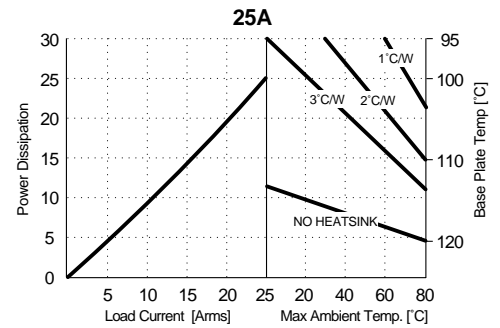
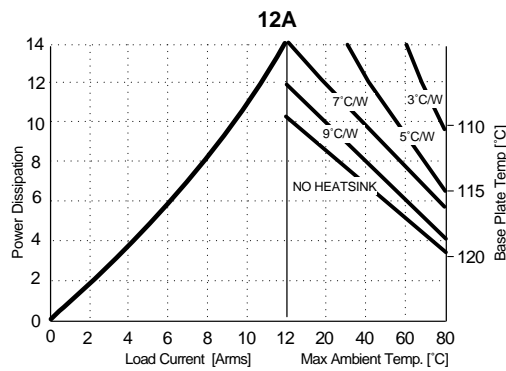

© 2003 CRYDOM CORP, Specifications subject to change without notice.

GENERAL SPECIFICATIONS

Dielectric Strength 50/60Hz Input/Output/Base	4000 Vrms
Insulation Resistance (Min.) @ 500 Vdc	10 ⁹ Ohm
Max. Capacitance Input/Output	8 pF
Ambient Operating Temperature Range	-40 to 80°C
Ambient Storage Temperature Range	-40 to 125°C

MECHANICAL SPECIFICATIONS

Weight: (typical)	3.0 oz. (86.5g)
Encapsulation:	Thermally Conductive Epoxy
Terminals:	Screws and Saddle Clamps Furnished, Unmounted

AVAILABLE OPTIONS

- 10** Random Turn-On (AC & DC Control)
Phase Controllable (DC Control)
Example: **D4890-10**
- F** Faston Terminals (Up to 25 Amp Models)
Example: **D4850F**
- H** Heat Transfer Pad (Attached)
Example: **D4850H**

Screw Torque Requirements:
6-32 Screws - 10 in. lbs.,
8-32 and 10-32 Screws - 20in. lbs.
(Screws dry without grease.)

Fastons:
Single pair (up to 25A)
Double pair* (up to 50A).
*Caution: User must connect to both pairs

Crydom Heat Sinks offer excellent thermal management and are perfectly matched to the load current ratings of Crydom panel mount relays. Request Crydom's Heat Sink specification sheet for all the details.

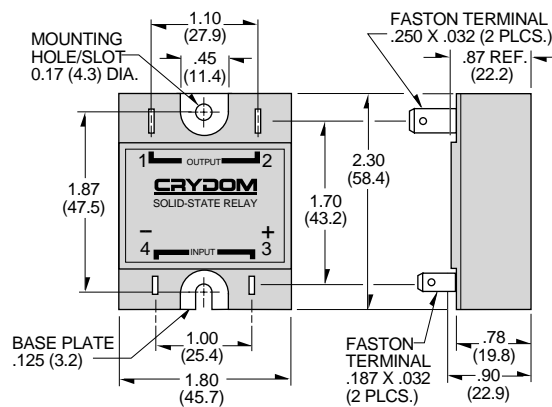
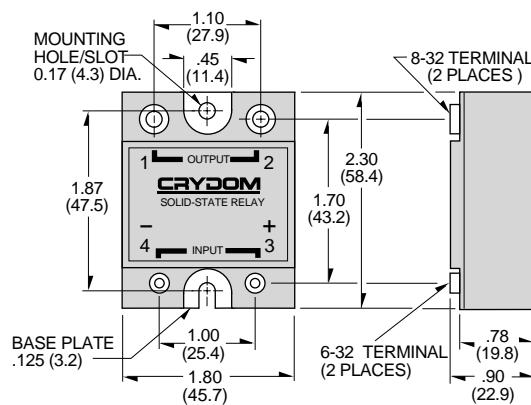

All dimensions are in inches (millimeters)

APPROVALS

UL E116949
CSA LR81689
VDE 10143 UG



FastFax Document No.
SERIES A48/D48
Rev. 111003
PAGE 2 OF 3

© 2003 CRYDOM CORP, Specifications subject to change without notice.

For recommended applications and more information contact:
USA: Sales Support (877) 502-5500 **Tech Support** (877) 702-7700 **FAX** (619) 710-8540
 Crydom Corp, 2320 Paseo de las Americas, Ste. 201, San Diego, CA 92154
Email: sales@crydom.com **WEB SITE:** http://www.crydom.com
UK: +44 (0)1202 365070 • **FAX** +44 (0)1202 365090 Crydom International Ltd., 7 Cobham Road, Ferndown Industrial Estate, Ferndown, Dorset BH21 7PE, **Email:** intsales@crydom.com.
GERMANY: +49 (0)180 3000 506



CURRENT DERATING CURVES

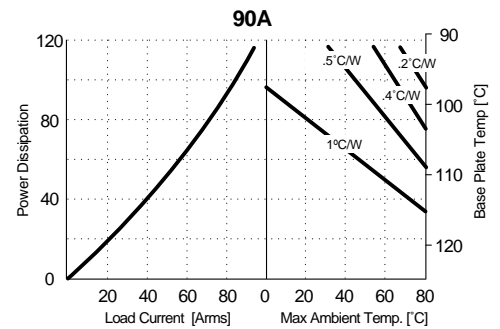
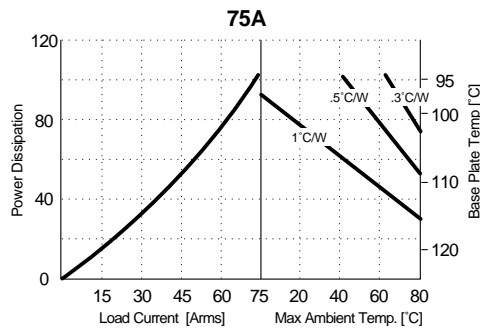
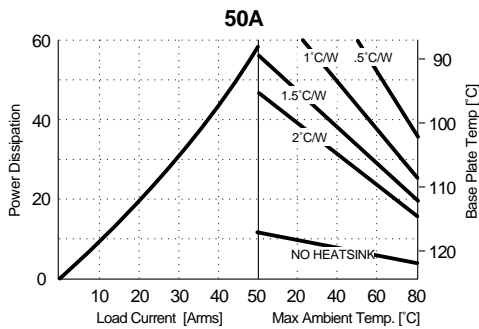
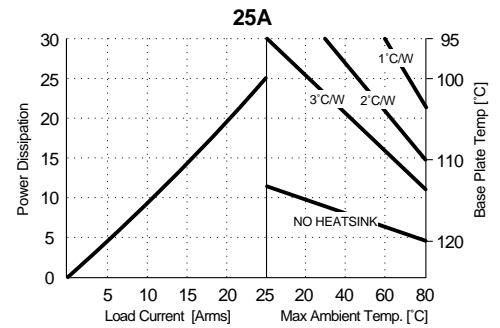
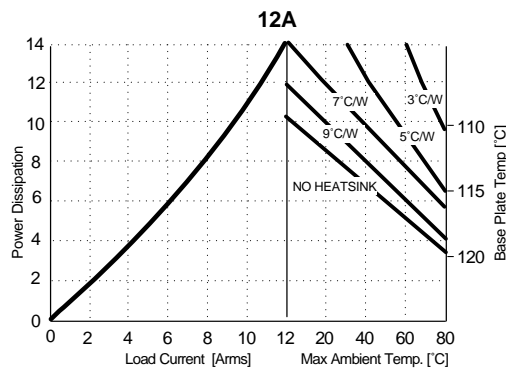

© 2003 CRYDOM CORP, Specifications subject to change without notice.

