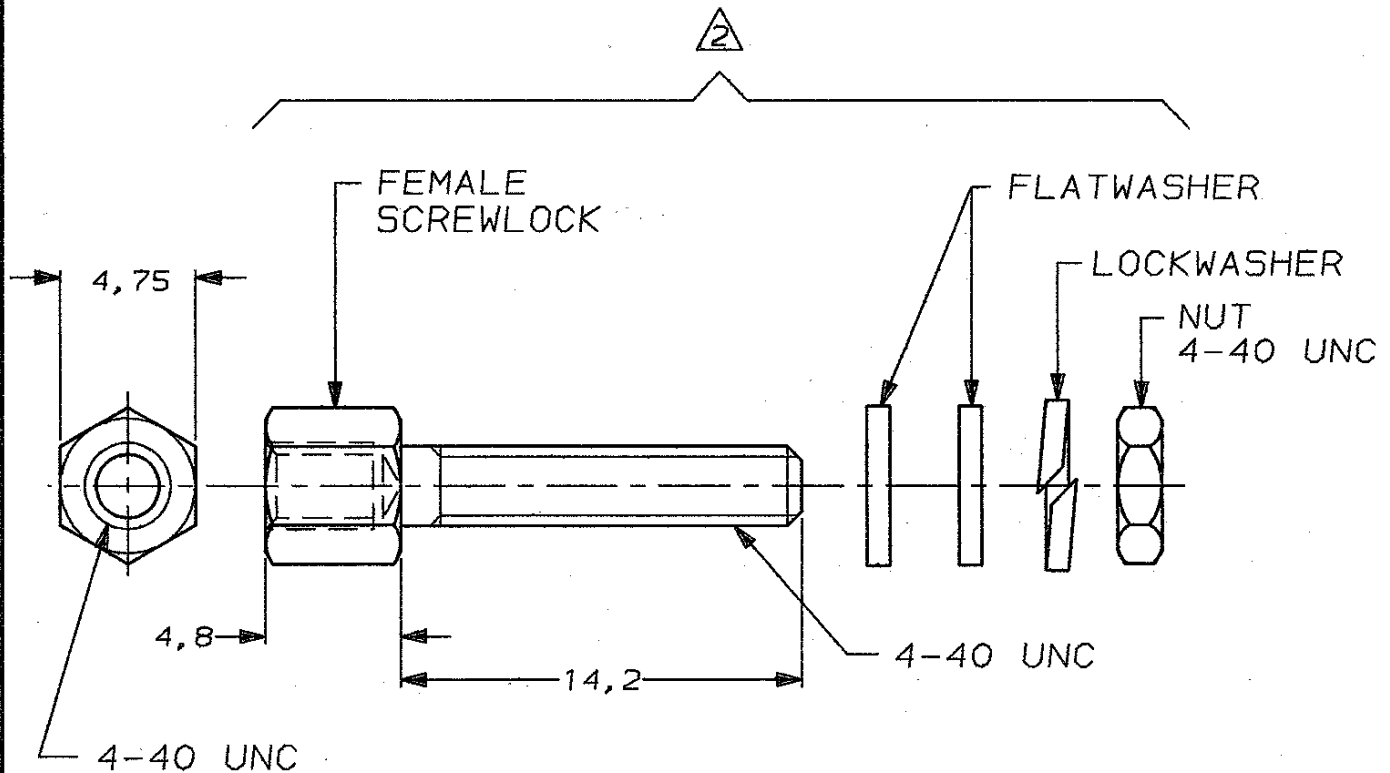

DO NOT SCALE

DIMENSIONS IN mm

METRIC

THIRD ANGLE
PROJECTION

- NOTES: 1 PARTS PACKAGED UNASSEMBLED
 2 THIS KIT CONTAINS TWO SCREWLOCK ASSEMBLIES
 3 BULKPACKAGE CONSISTS OF 50 KITS
 PLEASE ORDER IN UNITS OF 50 KITS
 4 FOR MOUNTING INSTRUCTIONS SEE I-042-087

BULKPACKAGED Δ_3	BRIGHT TINPLATED	STEEL	215072-2
BULKPACKAGED Δ_3	ZINC YELLOW CHROMATE		215072-1
DESCRIPTION	FINISH	MATERIAL	PARTNUMBER

CUSTOMER
DRAWING**AMP**

AMP-HOLLAND B.V.

's-Hertogenbosch, The Netherlands.

THIS DRAWING IS UNPUBLISHED | RELEASED FOR PUBLICATION | ,19

FOR REFERENCE ONLY
WILL NOT BE UPDATED© COPYRIGHT 19- BY AMP-HOLLAND B.V.
ALL INTERNATIONAL RIGHTS RESERVED.
AMP PRODUCTS MAY BE COVERED BY U.S. AND FOREIGN PATENTS AND/OR
PATENTS PENDING.

DR. P.D. JÄGER	DATE 10-04-89	WIRE RANGE -	NAME AMPLIMITE, KIT, FEMALE SCREWLOCK ASSEMBLY 4-40 UNC	REV. DATE D M Y 10 04 89
CHK. <i>e. Wilburg</i>	DATE 19-4-89	INSUL. RANGE -		
APP. <i>B</i>	DATE 5.6.89	SIZE A4	SHEET 1 OF 1	DWG. No. C-215072
				REV. LTR. A