

(Height includes  
standoff)

mm inch

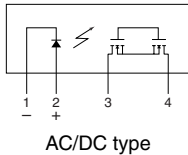
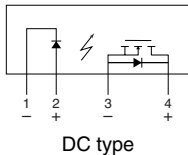

Compliance with RoHS Directive

## FEATURES

- 1. Slim SIL4-pin package**  
(W) 3.5 × (D) 21.0 × (H) 12.5 mm  
(W) .138 × (D) .827 × (H) .492 inch  
The compact size of the 4-pin SIL package allows high density mounting.
- 2. Extremely low on-resistance**
- 3. Control low-level signal**  
Power Photo MOS relays feature extremely low closed-circuit offset voltage to enable control of low-level analog signals without distortion.
- 4. Low-level off state leakage current of max. 10 μA**
- 5. High I/O isolation voltage of 2,500 V**
- 6. Eliminates the need for a counter electromotive protection diode in the drive circuit on the input side**
- 7. Eliminates the need for a power supply to drive the power MOSFET**
- 8. No restriction on mounting direction**
- 9. Low thermoelectromotive force**
- 10. Neither noise nor arc at contact**
- 11. Sockets are also available**  
(PA1a-PS, PA1a-PS-H)
- 12. Can be installed on the RT-3 relay terminal (Power PhotoMOS relay type)**

## TYPICAL APPLICATIONS

- Traffic signals
- Measuring instruments
- Industrial machines

## TYPES

### 1. DC type

	Output rating*		Package	Part No.	Packing quantity	
	Load voltage	Load current			Inner carton	Outer carton
DC only	60 V	4.0 A	SIL4-pin	AQZ102	25 pcs.	500 pcs.
	100 V	2.6 A		AQZ105		
	200 V	1.3 A		AQZ107		
	400 V	0.7 A		AQZ104		

\* Load voltage and current of DC type: DC

### 2. AC/DC type

	Output rating*		Package	Part No.	Packing quantity	
	Load voltage	Load current			Inner carton	Outer carton
AC/DC dual use	60 V	3.0 A	SIL4-pin	AQZ202	25 pcs.	500 pcs.
	100 V	2.0 A		AQZ205		
	200 V	1.0 A		AQZ207		
	400 V	0.5 A		AQZ204		

\* Load voltage and current of AC/DC type: Peak AC/DC.

**RATING****1. DC type****1) Absolute maximum ratings (Ambient temperature: 25°C 77°F)**

Item		Symbol	AQZ102	AQZ105	AQZ107	AQZ104	Remarks
Input	LED forward current	$I_F$	50 mA				
	LED reverse voltage	$V_R$	5 V				
	Peak forward current	$I_{FP}$	1 A				f = 100 Hz, Duty factor = 0.1%
	Power dissipation	$P_{in}$	75 mW				
Output	Load voltage (DC)	$V_L$	60 V	100 V	200 V	400 V	
	Continuous load current (DC)	$I_L$	4.0 A	2.6 A	1.3 A	0.7 A	
	Peak load current	$I_{peak}$	9.0 A	6.0 A	3.0 A	1.5 A	100 ms (1 shot), $V_L = DC$
	Power dissipation	$P_{out}$	1.35 W				
Total power dissipation		$P_T$	1.35 W				
I/O isolation voltage		$V_{iso}$	2,500 V AC				
Temperature limits	Operating	$T_{opr}$	-40°C to +85°C -40°F to +185°F				Non-condensing at low temperatures
	Storage	$T_{stg}$	-40°C to +100°C -40°F to +212°F				

**2) Electrical characteristics (Ambient temperature: 25°C 77°F)**

Item			Symbol	AQZ102	AQZ105	AQZ107	AQZ104	Condition
Input	LED operate current	Typical	$I_{Fon}$	1.0 mA				$I_L = 100 mA$ $V_L = 10 V$
		Maximum		3.0 mA				
	LED turn off current	Minimum	$I_{Foff}$	0.4 mA				$I_L = 100 mA$ $V_L = 10 V$
		Typical		0.9 mA				
	LED dropout voltage	Typical	$V_F$	1.25 V (1.16 V at $I_F = 10 mA$ )				$I_F = 50 mA$
		Maximum		1.5 V				
Output	On resistance	Typical	$R_{on}$	0.05 $\Omega$	0.081 $\Omega$	0.34 $\Omega$	1.06 $\Omega$	$I_F = 10 mA$ $I_L = Max.$ Within 1 s on time
		Maximum		0.09 $\Omega$	0.17 $\Omega$	0.55 $\Omega$	1.6 $\Omega$	
	Off state leakage current	Maximum	$I_{Leak}$	10 $\mu A$				$I_F = 0 mA$ $V_L = Max.$
	Transfer characteristics	Turn on time*	Typical	$T_{on}$	1.66 ms	1.89 ms	0.83 ms	1.01 ms
Maximum			5.0 ms					
Typical			3.79 ms		4.50 ms	1.75 ms	2.34 ms	
Maximum			10.0 ms					
Turn off time*		Typical	$T_{off}$	0.15 ms	0.19 ms	0.08 ms	0.08 ms	$I_F = 5 mA$ or 10 mA $I_L = 100 mA$ $V_L = 10 V$
		Maximum		3.0 ms				
I/O capacitance	Typical	$C_{iso}$	0.8 pF				f = 1 MHz $V_B = 0 V$	
	Maximum		1.5 pF					
Initial I/O isolation resistance	Minimum	$R_{iso}$	1,000 M $\Omega$				500 V DC	
Maximum operating speed	Maximum	—	0.5 cps				$I_F = 10 mA$ Duty factor = 50% $I_L \times V_L = 200 (VA)$	
Vibration resistance	Minimum	—	10 to 55 Hz at double amplitude of 3 mm				2 hours for 3 axes	
Shock resistance	Minimum	—	4,900 m/s <sup>2</sup> {500 G} 1 ms				3 times for 3 axes	

# Power 1 Form A (AQZ100, 200)

## 2. AC/DC type

### 1) Absolute maximum ratings (Ambient temperature: 25°C 77°F)

Item		Symbol	AQZ202	AQZ205	AQZ207	AQZ204	Remarks
Input	LED forward current	$I_F$	50 mA				
	LED reverse voltage	$V_R$	5 V				
	Peak forward current	$I_{FP}$	1 A				f = 100 Hz, Duty factor = 0.1%
	Power dissipation	$P_m$	75 mW				
Output	Load voltage (Peak AC)	$V_L$	60 V	100 V	200 V	400 V	
	Continuous load current	$I_L$	3.0 A	2.0 A	1.0 A	0.5 A	Peak AC, DC
	Peak load current	$I_{peak}$	9.0 A	6.0 A	3.0 A	1.5 A	100 ms (1 shot), $V_L = DC$
	Power dissipation	$P_{out}$	1.6 W				
Total power dissipation		$P_T$	1.6 W				
I/O isolation voltage		$V_{iso}$	2,500 V AC				
Temperature limits	Operating	$T_{opr}$	-40°C to +85°C -40°F to +185°F				Non-condensing at low temperatures
	Storage	$T_{stg}$	-40°C to +100°C -40°F to +212°F				

### 2) Electrical characteristics (Ambient temperature: 25°C 77°F)

Item		Symbol	AQZ202	AQZ205	AQZ207	AQZ204	Condition
Input	LED operate current	Typical	1.0 mA				$I_L = 100 mA$ $V_L = 10 V$
		Maximum	3.0 mA				
	LED turn off current	Minimum	0.4 mA				$I_L = 100 mA$ $V_L = 10 V$
		Typical	0.9 mA				
LED dropout voltage	Typical	1.25 V (1.16 V at $I_F = 10 mA$ )				$I_F = 50 mA$	
	Maximum	1.5 V					
Output	On resistance	Typical	0.11 Ω	0.23 Ω	0.7 Ω	2.1 Ω	$I_F = 10 mA$ $I_L = Max.$ Within 1 s on time
		Maximum	0.18 Ω	0.34 Ω	1.1 Ω	3.2 Ω	
	Off state leakage current	Maximum	10 μA				$I_F = 0 mA$ $V_L = Max.$
Transfer characteristics	Turn on time*	Typical	2.46 ms	2.40 ms	1.12 ms	1.65 ms	$I_F = 10 mA$ $I_L = 100 mA$ $V_L = 10 V$
		Maximum	5.0 ms				
		Typical	5.64 ms	5.65 ms	2.57 ms	3.88 ms	
		Maximum	10.0 ms				
	Turn off time*	Typical	0.22 ms	0.21 ms	0.10 ms	0.08 ms	$I_F = 5 mA$ or 10 mA $I_L = 100 mA$ $V_L = 10 V$
		Maximum	3.0 ms				
	I/O capacitance	Typical	0.8 pF				f = 1 MHz $V_B = 0 V$
		Maximum	1.5 pF				
Initial I/O isolation resistance	Minimum	1,000 MΩ				500 V DC	
Maximum operating speed	Maximum	0.5 cps				$I_F = 10 mA$ Duty factor = 50% $I_L = Max., V_L = Max.$	
Vibration resistance	Minimum	10 to 55 Hz at double amplitude of 3 mm				2 hours for 3 axes	
Shock resistance	Minimum	4,900 m/s <sup>2</sup> {500 G} 1 ms				3 times for 3 axes	

\*Turn on/off time

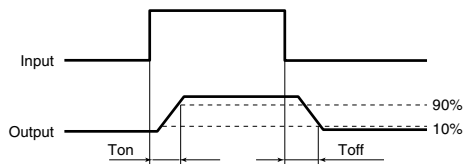

## RECOMMENDED OPERATING CONDITIONS

Please obey the following conditions to ensure proper relay operation and resetting.

Item	Symbol	Recommended value	Unit
Input LED current	$I_F$	5 to 10	mA

- For Dimensions.
- For Schematic and Wiring Diagrams.
- For Cautions for Use.

■ These products are not designed for automotive use.

If you are considering to use these products for automotive applications, please contact your local Panasonic Electric Works technical representative.  
For more information.

## REFERENCE DATA

1.-(1) Load current vs. ambient temperature characteristics (DC type)

Allowable ambient temperature:  $-40^{\circ}\text{C}$  to  $+85^{\circ}\text{C}$   
 $-40^{\circ}\text{F}$  to  $+185^{\circ}\text{F}$

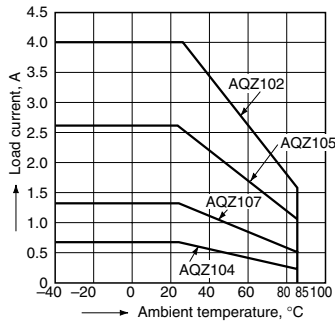

1.-(2) Load current vs. ambient temperature characteristics (AC/DC type)

Allowable ambient temperature:  $-40^{\circ}\text{C}$  to  $+85^{\circ}\text{C}$   
 $-40^{\circ}\text{F}$  to  $+185^{\circ}\text{F}$

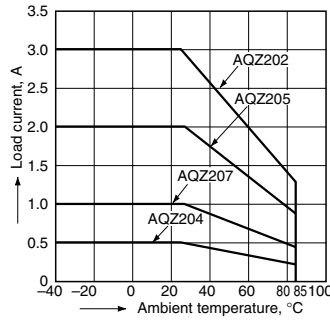

2. Load current vs. ambient temperature characteristics in adjacent mounting

$I_L$ : Load current;  
 $I_L$  (max.): Maximum continuous load current

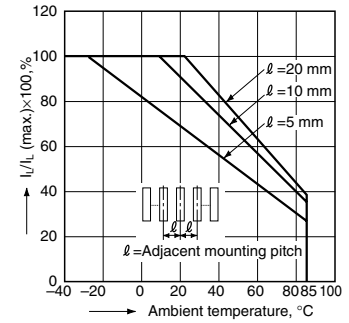

3.-(1) On resistance vs. ambient temperature characteristics (DC type)

LED current: 10 mA;  
 Continuous load current: 1.6 A (DC) (AQZ102),  
 1.04 A (DC) (AQZ105)

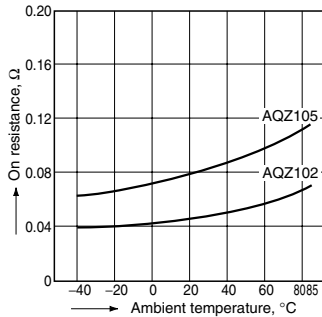

3.-(2) On resistance vs. ambient temperature characteristics (DC type)

LED current: 10 mA;  
 Continuous load current: 0.52 A (DC) (AQZ107),  
 0.28 A (DC) (AQZ104)

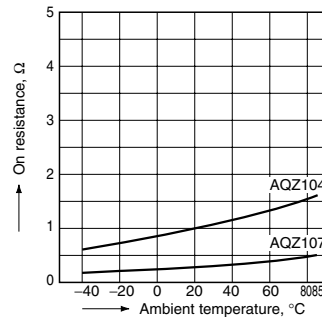

3.-(3) On resistance vs. ambient temperature characteristics (AC/DC type)

LED current: 10 mA;  
 Continuous load current: 1.2 A (DC) (AQZ202),  
 0.8 A (DC) (AQZ205)

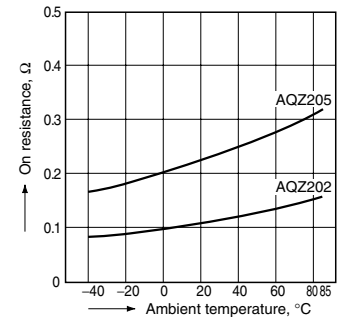

3.-(4) On resistance vs. ambient temperature characteristics (AC/DC type)

LED current: 10 mA;  
 Continuous load current: 0.4 A (DC) (AQZ207),  
 0.2 A (DC) (AQZ204)

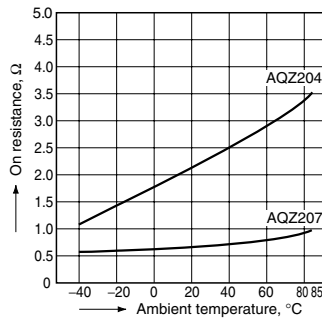

4.-(1) Turn on time vs. ambient temperature characteristics (DC type)

LED current: 10 mA;  
 Load voltage: 10 V (DC);  
 Continuous load current: 100 mA (DC)

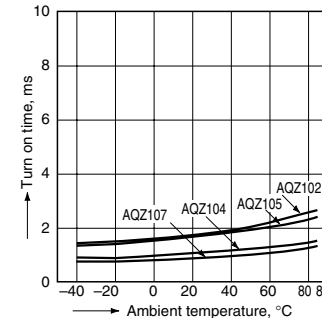

4.-(2) Turn on time vs. ambient temperature characteristics (AC/DC type)

LED current: 10 mA;  
 Load voltage: 10 V (DC);  
 Continuous load current: 100 mA (DC)

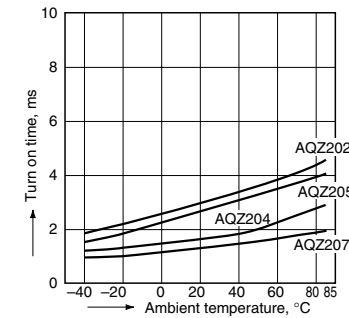

5.-(1) Turn off time vs. ambient temperature characteristics (DC type)

LED current: 10 mA;  
 Load voltage: 10 V (DC);  
 Continuous load current: 100 mA (DC)

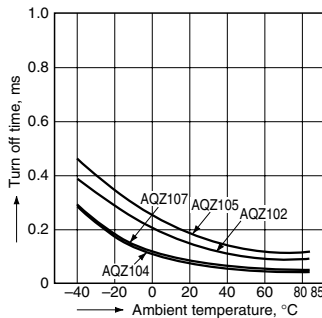

5.-(2) Turn off time vs. ambient temperature characteristics (AC/DC type)

LED current: 10 mA;  
 Load voltage: 10 V (DC);  
 Continuous load current: 100 mA (DC)

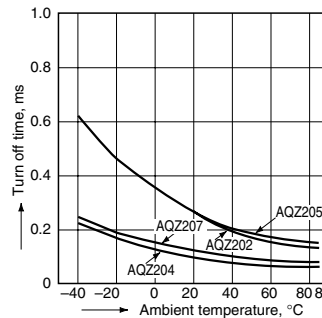

6.-(1) LED operate vs. ambient temperature characteristics (DC type)

Load voltage: 10 V (DC);  
 Continuous load current: 100 mA (DC)

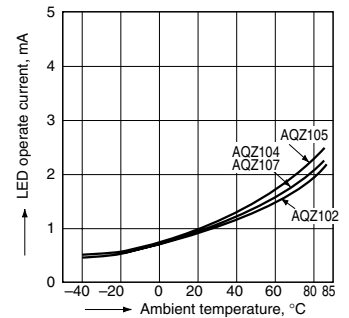

# Power 1 Form A (AQZ100, 200)

6.-(2) LED operate vs. ambient temperature characteristics (AC/DC type)

Load voltage: 10 V (DC);  
Continuous load current: 100 mA (DC)

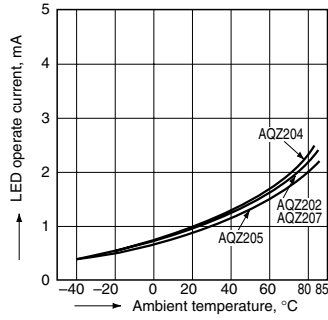

7.-(1) LED turn off current vs. ambient temperature characteristics (DC type)

Load voltage: 10 V (DC);  
Continuous load current: 100 mA (DC)

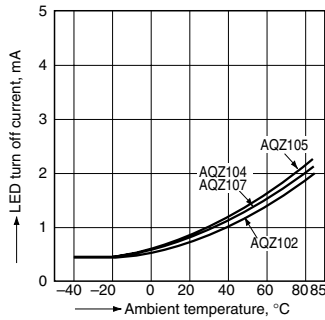

7.-(2) LED turn off current vs. ambient temperature characteristics (AC/DC type)

Load voltage: 10 V (DC);  
Continuous load current: 100 mA (DC)

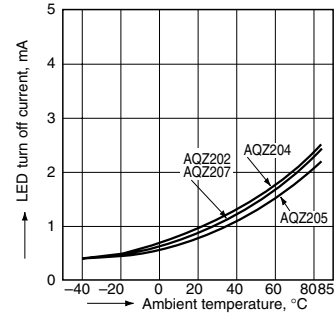

8. LED dropout voltage vs. ambient temperature characteristics

Sample: all types; LED current: 5 to 50 mA

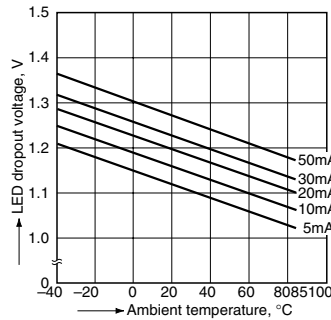

9.-(1) Current vs. voltage characteristics of output at MOS portion (DC type)

Ambient temperature: 25°C 77°F

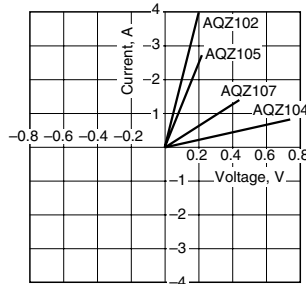

9.-(2) Current vs. voltage characteristics of output at MOS portion (AC/DC type)

Ambient temperature: 25°C 77°F

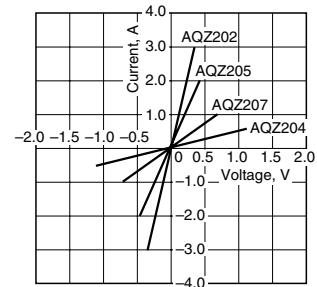

10.-(1) Off state leakage current vs. load voltage characteristics

Ambient temperature: 25°C 77°F

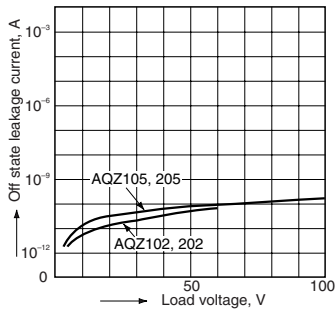

10.-(2) Off state leakage current vs. load voltage characteristics

Ambient temperature: 25°C 77°F

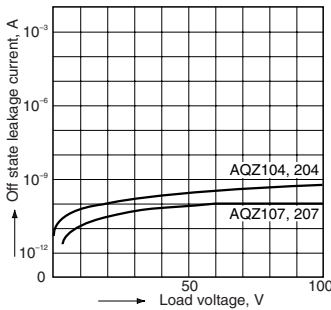

11.-(1) Turn on time vs. LED forward current characteristics (DC type)

Load voltage: 10 V (DC);  
Continuous load current: 100 mA (DC);  
Ambient temperature: 25°C 77°F

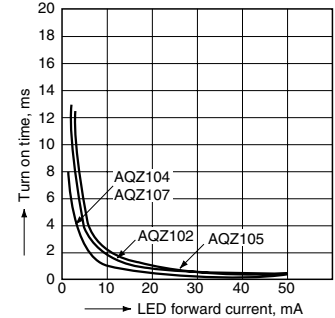

11.-(2) Turn on time vs. LED forward current characteristics (AC/DC type)

Load voltage: 10 V (DC);  
Continuous load current: 100 mA (DC);  
Ambient temperature: 25°C 77°F

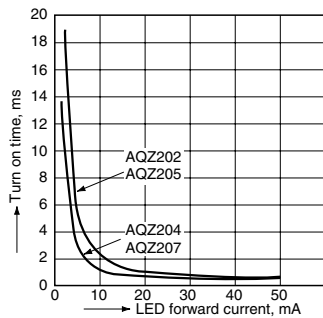

12.-(1) Turn off time vs. LED forward current characteristics (DC type)

Measured portion: between terminals 4 and 6;  
Load voltage: 10 V (DC);  
Continuous load current: 100 mA (DC);  
Ambient temperature: 25°C 77°F

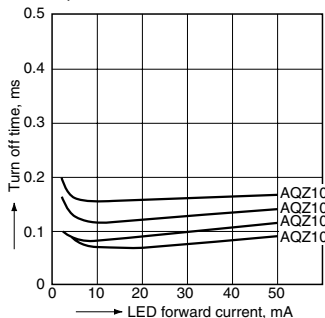

12.-(2) Turn off time vs. LED forward current characteristics (AC/DC type)

Load voltage: 10 V (DC);  
Continuous load current: 100 mA (DC);  
Ambient temperature: 25°C 77°F

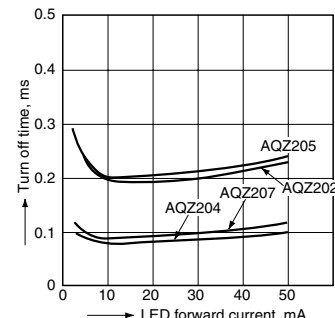

# Power 1 Form A (AQZ100, 200)

13.-(1) Turn on time vs. load voltage characteristics (DC type)

LED current: 10 mA;  
Continuous load current: 100 mA;  
Ambient temperature: 25°C 77°F

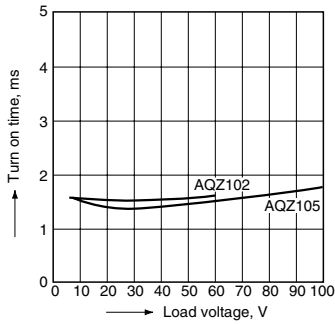

13.-(2) Turn on time vs. load voltage characteristics (DC type)

LED current: 10 mA;  
Continuous load current: 100 mA;  
Ambient temperature: 25°C 77°F

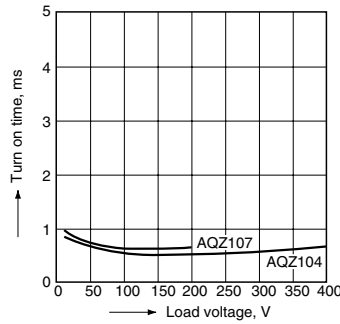

13.-(3) Turn on time vs. load voltage characteristics (AC/DC type)

LED current: 10 mA;  
Continuous load current: 100 mA;  
Ambient temperature: 25°C 77°F

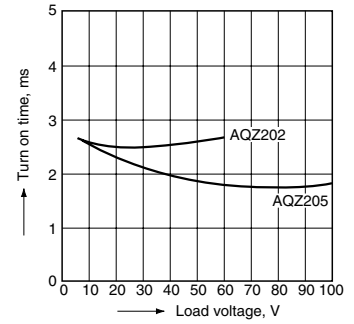

13.-(4) Turn on time vs. load voltage characteristics (AC/DC type)

LED current: 10 mA;  
Continuous load current: 100 mA;  
Ambient temperature: 25°C 77°F

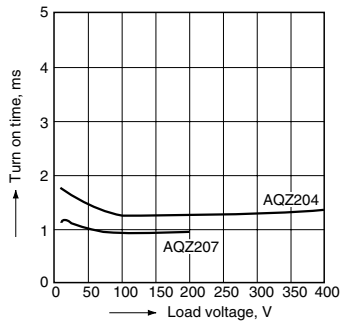

14.-(1) Turn on time vs. load current characteristics (DC type)

LED current: 10 mA;  
Load voltage: 10 V (DC);  
Ambient temperature: 25°C 77°F

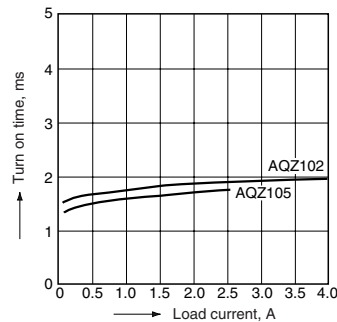

14.-(2) Turn on time vs. load current characteristics (DC type)

LED current: 10 mA;  
Load voltage: 10 V (DC);  
Ambient temperature: 25°C 77°F

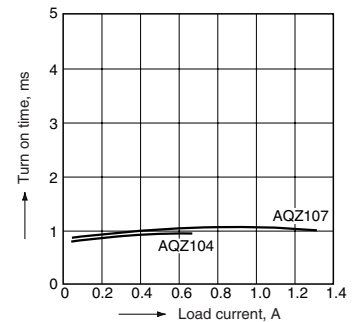

14.-(3) Turn on time vs. load current characteristics (AC/DC type)

LED current: 10 mA;  
Load voltage: 10 V (DC);  
Ambient temperature: 25°C 77°F

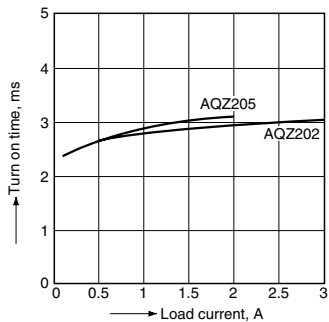

14.-(4) Turn on time vs. load current characteristics (AC/DC type)

LED current: 10 mA;  
Load voltage: 10 V (DC);  
Ambient temperature: 25°C 77°F

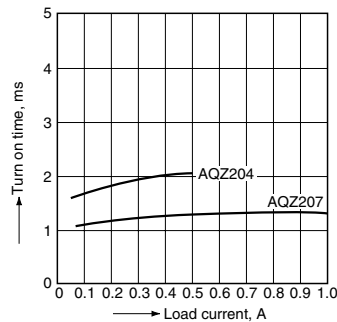

15.-(1) Turn off time vs. load voltage characteristics (DC type)

LED current: 10 mA;  
Continuous load current: 100 mA;  
Ambient temperature: 25°C 77°F

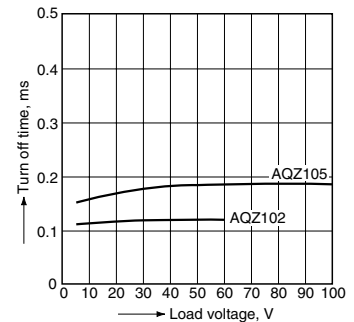

15.-(2) Turn off time vs. load voltage characteristics (DC type)

LED current: 10 mA;  
Continuous load current: 100 mA;  
Ambient temperature: 25°C 77°F

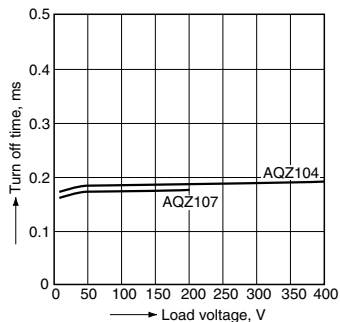

15.-(3) Turn off time vs. load voltage characteristics (AC/DC type)

LED current: 10 mA;  
Continuous load current: 100 mA;  
Ambient temperature: 25°C 77°F

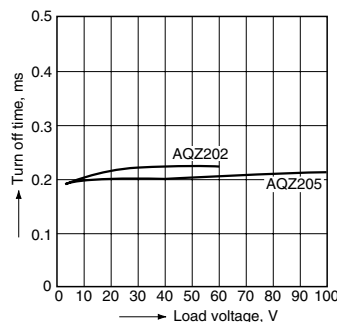

15.-(4) Turn off time vs. load voltage characteristics (AC/DC type)

LED current: 10 mA;  
Continuous load current: 100 mA;  
Ambient temperature: 25°C 77°F

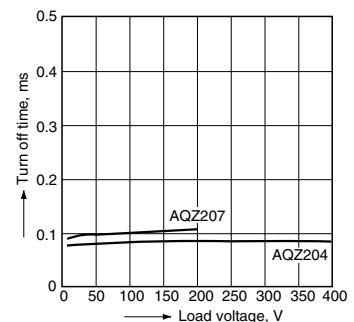

# Power 1 Form A (AQZ100, 200)

## 16.-(1) Turn off time vs. load current characteristics (DC type)

LED current: 10 mA;  
Load voltage: 10 V (DC);  
Ambient temperature: 25°C 77°F

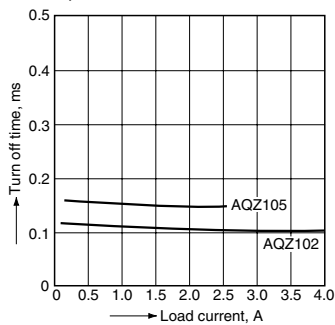

## 16.-(2) Turn off time vs. load current characteristics (DC type)

LED current: 10 mA;  
Load voltage: 10 V (DC);  
Ambient temperature: 25°C 77°F

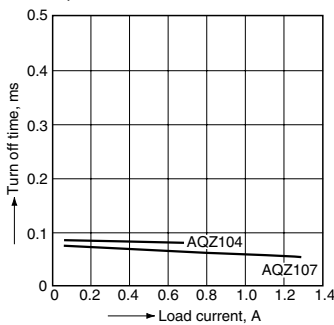

## 16.-(3) Turn off time vs. load current characteristics (AC/DC type)

LED current: 10 mA;  
Load voltage: 10 V (DC);  
Ambient temperature: 25°C 77°F

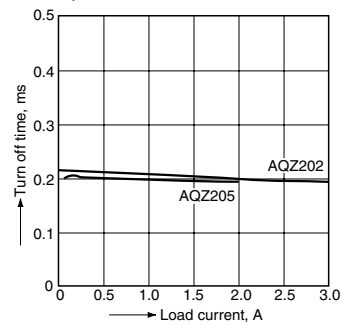

## 16.-(4) Turn off time vs. load current characteristics (AC/DC type)

LED current: 10 mA;  
Load voltage: 10 V (DC);  
Ambient temperature: 25°C 77°F

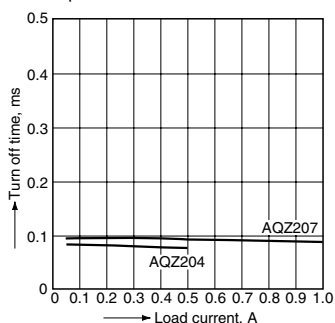

## 17. Maximum operating frequency vs. load voltage/current characteristics

LED current: 10 mA;  
Ambient temperature: 25°C 77°F

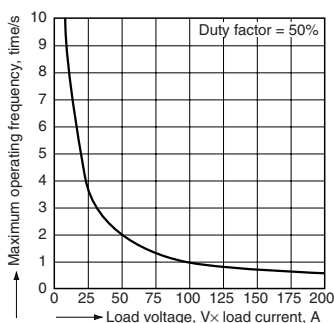

## 18.-(1) Output capacitance vs. applied voltage characteristics (DC type)

Frequency: 1 MHz;  
Ambient temperature: 25°C 77°F

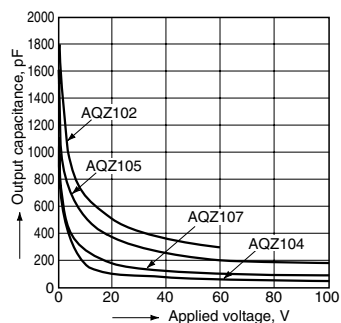

## 18.-(2) Output capacitance vs. applied voltage characteristics (AC/DC type)

Frequency: 1 MHz;  
Ambient temperature: 25°C 77°F

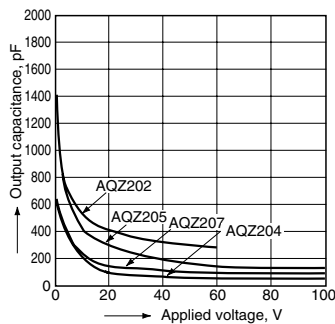

## ACCESSORY (mm inch)

### Socket

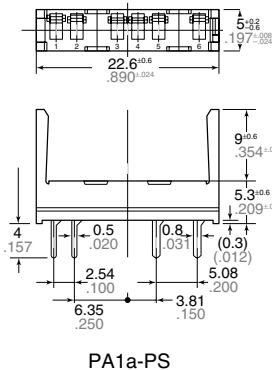

PA1a-PS

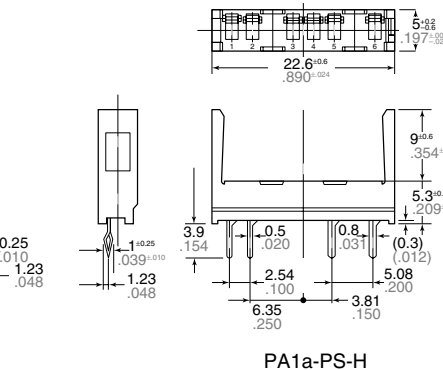

PA1a-PS-H

### PC board pattern (BOTTOM VIEW)

#### Standard type

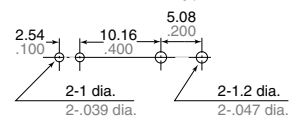

#### Self clinching type

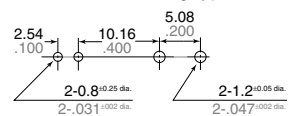

Tolerance: ±0.1 ±.004