

Solid State Relays Analog Full Cycle Switching Type RN.F...



- AC solid state relay, 1- and 2-poles
- Analog switching for resistive loads (heating)
- 4-20 mA or 0-10 V controls
- Rated operational current: 1-pole : 30A and 50A
2-pole : 2 x15A and 2 x 25A
- Rated operational voltage up to 480 VAC
- LED-indication for normal operation and alarm status
- IP 20 protection
- DIN-rail mountable

Product Description

The analog switching relay provides a number of full cycles, evenly distributed over a fixed period, depending of the control input. The input of 4-20 mA or 0-10 VDC respectively, corresponds to zero and full output within a period of 1.28 s @ 50 Hz (1.07 s @ 60 Hz). This principle makes the transfer characteristics fully linear. The

principle operates with zero switching, thus ensuring a reduced level of radiated and wire conducted noise. The 2-pole type has alarm LED indication by loss of master phase. The analogue Full Cycle Switching is not recommended for light control due to light-flickering.

Ordering Key

RN 1 F 40 V 30

- Solid State Relay
- Number of poles
- Switching type
- Rated operational voltage
- Control signal
- Rated operational current

Type Selection, 1-Pole

Rated operational voltage	Control input	Control supply	Rated operational current	
			30 A	50 A
120 VAC	4-20 mA	7-10 VDC	RN 1F12I30	RN 1F12I50
	0-10 VDC	12-32 VDC, 24 VAC	RN 1F12V30	RN 1F12V50
230 VAC	4-20 mA	7-10 VDC	RN 1F23I30	RN 1F23I50
	0-10 VDC	12-32 VDC, 24 VAC	RN 1F23V30	RN 1F23V50
480 VAC	4-20 mA	7-10 VDC	RN 1F48I30	RN 1F48I50
	0-10 VDC	12-32 VDC, 24 VAC	RN 1F48V30	RN 1F48V50

Type Selection, 2-Pole

Rated operational voltage	Control input	Control supply	Rated operational current	
			30 A Total (2 x 15A)	50 A Total (2 x 25A)
120 VAC	4-20 mA	7-10 VDC	RN 2F12I30	RN 2F12I50
	0-10 VDC	12-32 VDC, 24 VAC	RN 2F12V30	RN 2F12V50
230 VAC	4-20 mA	7-10 VDC	RN 2F23I30	RN 2F23I50
	0-10 VDC	12-32 VDC, 24 VAC	RN 2F23V30	RN 2F23V50
480 VAC	4-20 mA	7-10 VDC	RN 2F48I30	RN 2F48I50
	0-10 VDC	12-32 VDC, 24 VAC	RN 2F48V30	RN 2F48V50

General Specifications

	RN.F12...	RN.F23...	RN.F48...
Operational voltage range	85 to 140 VAC	85 to 265 VAC	190 to 530 VAC
Non-rep. peak voltage	800 V _p	800 V _p	1000 V _p
Varistor voltage	275 VAC	275 VAC	510 VAC
Zero voltage turn-on	< 10 V	< 10 V	< 20 V
Operational frequency range	45 to 65 Hz	45 to 65 Hz	45 to 65 Hz
Power factor at rated voltage	≥ 0.9	≥ 0.9	≥ 0.9
Average output power	0 to 100%	0 to 100%	0 to 100%
Output power resolution	1/64 of 100%	1/64 of 100%	1/64 of 100%
Approvals	UL, cUL, CSA	UL, cUL, CSA	UL, cUL, CSA
CE-marking	Yes	Yes	Yes

Norms fulfilled EN 60947-1 Low-voltage switchgear and control gear. Part 1- General Rules.
 EN 61000-6-1 Generic Immunity Standard. Residential, Commercial & Light Industry Environment
 EN 61000-6-2 Generic Immunity Standard. Industrial Environment

Input Specifications

	RN.F..I..	Voltage controlled input	RN.F..V..
Current controlled input			
Control current range	4 - 20 mA	Supply voltage range	21 - 27 VAC, 12 - 32 VDC
Allowable input current	50 mA	Supply current	30 mA @ 24 VAC/32 VDC
Reverse polarity protected	Yes	Control voltage range	0 - 10 V
Voltage drop	10 VDC @ 20 mA	Control input current	0.1 mA @ 10 VDC

Output Specifications

	RN.F..30	RN.F..50
Rated operational current		
RN1F.. AC51 @Ta=30°C	30 A	50 A
" @Ta=40°C	30 A	50 A
" @Ta=50°C	23 A	38 A
" @Ta=60°C	20 A	30 A
RN2F.. AC51 @Ta=30°C	30 A total sum (2 x 15A)	50 A total sum (2 x 25A)
" @Ta=40°C	30 A total sum (2 x 15A)	50 A total sum (2 x 25A)
" @Ta=50°C	23 A total sum (2 x 11.5A)	38 A total sum (2 x 19A)
" @Ta=60°C	20 A total sum (2 x 10A)	30 A total sum (2 x 15A)
Zero crossing detection	Yes	Yes
Min. operational current (per pole)	500 mA	500 mA
Rep. overload current t=1 s (T _j init.=25°C)	55 A (rms)	125 A (rms)
Non-rep. surge current t=10 ms (T _j init.=25°C)	< 250 A _p	< 600 A _p
Off-state leakage current, @ rated voltage and frequency (T _j .=125°C, max.)	< 6 mA	< 6 mA
I ² t for fusing t=1 to 10 ms	310 A ² s	1800 A ² s
Critical dV/dt off-state	500 V/μs	500 V/μs

Thermal Specifications

	RN.F..30	RN.F..50
Operational temperature	-20° to +70°C (-4° to +158°F)	-20° to +70°C (-4° to +158°F)
Storage temperature	-20° to +100°C (-4° to +212°F)	-20° to +100°C (-4° to +212°F)
Junction temperature	< 125°C (257°F)	< 125°C (257°F)
R _{th} junction to ambient (AC load)	2.8 K/W	1.7 K/W

Housing Specifications

Mounting	DIN-rail 35 mm
Weight with RHN1	470 g
Weight with RHN2	780 g
Housing material	Noryl SEI, GFN1, Black
LED window material	PC Lexan 141R
Base plate	Aluminium, nickel plated
Potting compound	Polyurethane, Casco Nobel
Terminals	Screw with captive wire clamp
Control terminals nominal	4 mm ² or 2 x 2.5 mm ² AWG 12 or 2 x AWG 14
Min. Mounting torque max.	0.5 mm ² , AWG 20 0.6 Nm
Power terminals nominal	10 mm ² or 2 x 6 mm ² AWG 6 or 2 x AWG 10
Min. Mounting torque max.	1 mm ² , AWG 16 2.0 Nm
Heatsink compound used	Electrolube HTS

Insulation

Rated impulse withstand voltage	4000 V _{imp}
Input to output	
Rated impulse withstand voltage	4000 V _{imp}
Output to heatsink	

Environment Specifications

Humidity max.	95%, no condensation
---------------	----------------------

Dimensions

Dimensions	(H x W x D)
RN..30	120 x 45 x 110 mm
RN..50	120 x 90 x 110 mm

Dimensions

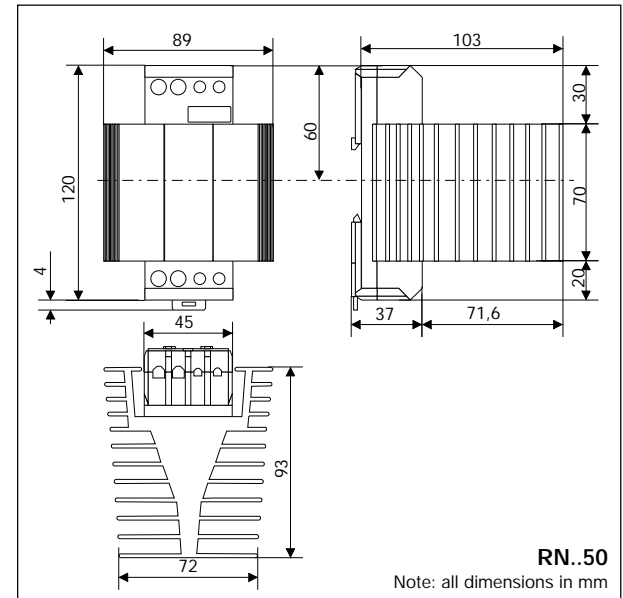
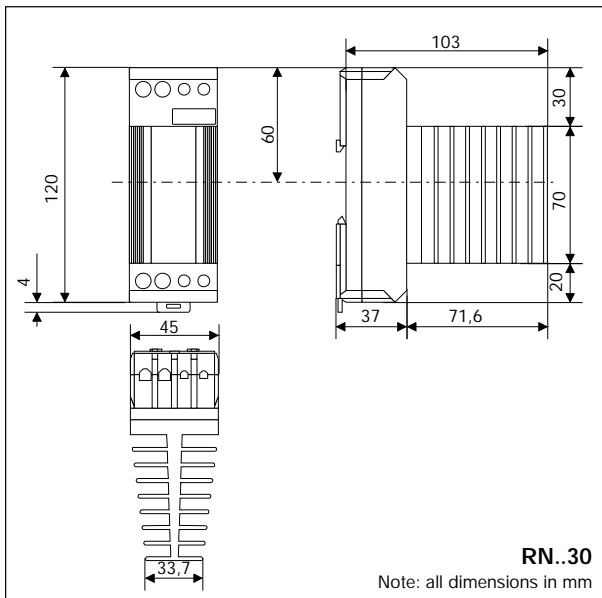

Wiring Diagrams

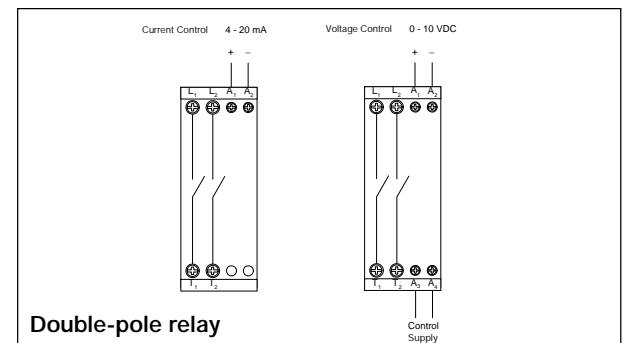
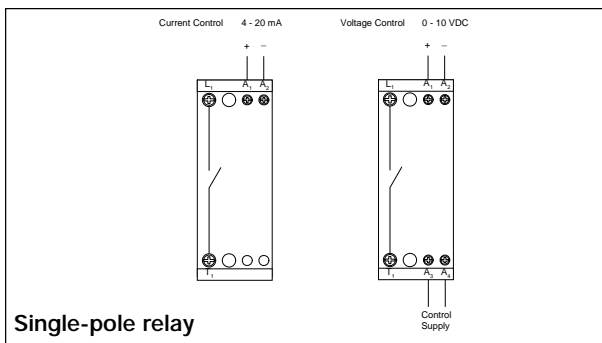

Terminal Layout

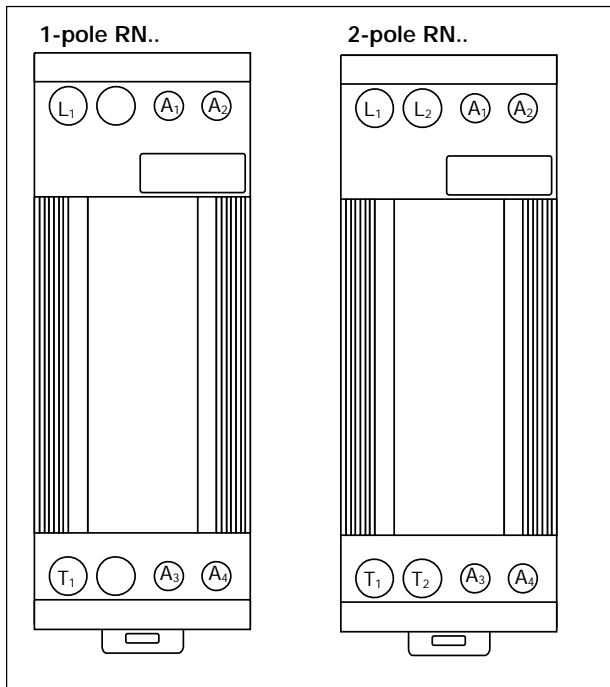

Functional Diagrams

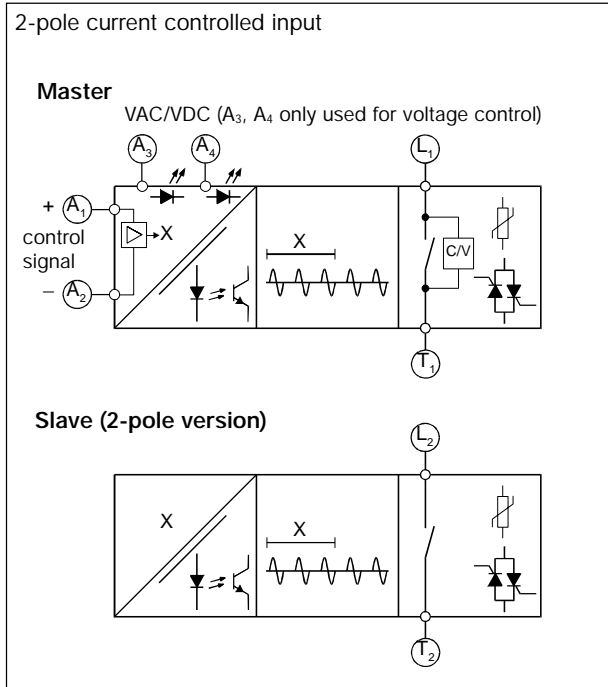

Applications

