

Digital signalling

Digital signalling

Relays – overview	C.2
Relays – DK-SERIES	C.10
Relays – MCZ-SERIES	C.14
Relays – MCZ-TRAK-SERIES	C.16
Relays – MCZ-SERIES accessories	C.20
Relays – MICROSERIES	C.22
PLC digital interfaces	C.28
Relays – PLUGSERIES	C.30
Relays – RIDERSERIES	C.36
Relays – RS-SERIES – RS 30	C.72
Relays – RS-SERIES – RS 31	C.74
Relays – RS-SERIES – RS 32	C.76
Relays – RS-SERIES – RS 32 Safety	C.79
Relays – RS-SERIES – with RSM multiple interface	C.80
Relays – WAVESERIES	C.82
Optos – overview	C.88
Optos – DK-SERIES	C.96
Optos – MCZ-SERIES	C.101
Optos – MCZ-TRAK-SERIES	C.104
Optos – MICROSERIES	C.106
Optos – MICROOPTO	C.112
Solid-state relay – MICROOPTO	C.113
Optos – PLUGSERIES	C.116
Optos – RSO-SERIES	C.120
Optos – WAVESERIES	C.122
Power solid-state relay	C.128
Timer relays – BT-SERIES	C.132
Timer relays – DK-SERIES	C.138
Timer relays – MCZ-SERIES	C.141

Housing forms for relays

DK-SERIES



All components of the DKR mini-coupler are extremely slim: the use of the latest surface-mounted devices (SMD) allows us to keep the width to just 6 mm. The mini-couplers support a wide range of applications relating to the coupling of digital sensor/actuator signals with automation devices and the process field. DKR relays are designed to pick up and standardise signals of different voltages from the field.

MICROSERIES



The **MICROSERIES** range integrates the product features of the RSS power relay into the world of terminals. The user therefore benefits from the special features of terminals by retaining a free choice of connection systems, plug-in cross-connections, standardised marking solutions as well as the space saving advantage typical of relays!

RIDERSERIES



The **RIDERSERIES** range represents the successful integration of the families RCL, RCI, RCM, RRD and RPW into the Weidmüller relay programme. This modular series conforms to the international standard. The many pluggable variants are available from 1 way to 4-way changeover contacts with a free choice of connection system.

MCZ-SERIES



The MCZ enclosure is only 6 mm wide and one of the narrowest of its kind. Its outstanding technical features include:

- Tension clamp connection to reduce assembly costs
- Integrated cross-connection in input and output minimizes wiring workload

PLUGSERIES



The **PLUGSERIES** offers you proven product features from the world of connection systems combined with the performance of the Weidmüller RCL power relay. The plug-in cross-connection ZQV enables quick and easy bridging of input and output potentials. Besides a free choice of connection systems, PLUGSERIES products are unique as a result of the Wemid housing material.

RS-SERIES

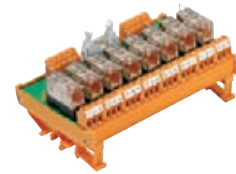

Clip-on bases with relays RS 30, 31, 32 have a width of 11.2 mm to 25 mm – depending on the type. RSM multiple interfaces are assembled with a choice of 4, 8 or 16 relays. Versions with a common plus or minus potential are available to save wiring on the input side. LP connection elements are equipped with clamping yoke units for screw connection.

WAVESERIES



Innovative electronic components require a housing or enclosure that reflects their specific functions. They must allow adjustment and operation functions and support electro-mechanical requirements such as heat dissipation or electromagnetic compatibility. A compact design saves space in the control cabinet and reduces assembly costs. Ergonomic design is increasingly important for top-quality relay interfaces.

JACKPAC®



JACKPAC® integrates basic functions of signal processing such as amplification, isolation and conversion of signals, but also provides protective functions thanks to packaging to IP68 standard that is compatible with field wiring conditions. This allows you to both realise decentralised wiring concepts without having to accept a compromise solution and optimally use digital input-output modules from the IP6X world.

Relay couplers – an overview

C

Historical background

The term 'relay' was originally used for a station where stagecoaches were able to change their tired horses for fresh ones. The term 'relay' was given a totally different meaning by the English physicist Charles Wheatstone (1802–1875). In Wheatstone's times, departing trains were signalled by a ringing bell at the next railway station up the line.

This was achieved by connecting a battery in the first station to a bell in the second. However, as the railway stations were generally several kilometres apart the power arriving at the second station was often insufficient to ring the bell. Wheatstone invented a switchgear apparatus that was installed at the second railway station. This continued to function even with low power supply levels. The switchgear apparatus switched a second electrical circuit that actuated the bell. That was the birth of the electromagnetic relay.

How a relay functions

A relay is an electromagnetic switch comprising two galvanically isolated circuits. Firstly the control circuit and secondly the open circuit with the normally open contact. As soon as the control circuit is energised, the coil creates a magnetic field in the core/yoke and attracts the armature. The actuator now actuates the switch at the output, the normally open contact (make contact) closes and the normally closed contact (break contact) opens. When the control circuit is turned off, the magnetic field diminishes and the return spring returns the armature to its initial position. The actuator moves the normally open (make contact) back to its normal position, the normally open contact opens, the normally closed contact (break contact) closes.

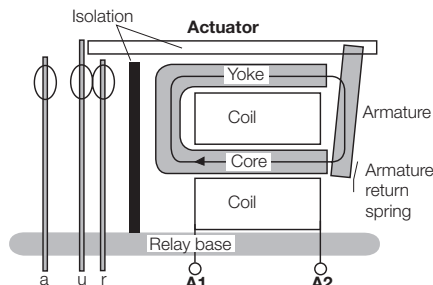

Consequently, with low power input – battery power for example – a relay provides the option of switching heavy loads as well as being able to serve as a switching amplifier. Thanks to the isolation between the input and output, relays are also suitable for providing separation when the power of the control and the open circuits differ. Equipped with several NO (make) contacts, a relay can also be utilised for multiplying signals.

From relay to relay coupler

There are two alternative methods that make a relay coupler suitable for use in industrial applications: mounting onto a PCB – in combination with the corresponding assembly techniques and circuitry – or plugging onto a specially designed relay base.

Generally, the design and rating data determine if a relay coupler is or is not suitable for a particular application.

For example, relay couplers with plugged on relays are only partly suitable for use in applications subjected to heavy vibrations. In this case, relay couplers with soldered relays should be preferred. Low, compact designs such as those provided by the RIDERSERIES are utilised in small consumer units where the overall available height is limited. Conversely, the compact design of the MICROSERIES helps to save space in electrical cabinets.

Protective separation

It is essential that all electrical equipment required to provide protective separation be designed in such a manner that the insulation cannot be impaired, for example by mechanical errors. If a mechanical error occurs in a relay (bent soldering pin, broken winding wire or broken spring), 'protective separation' must be guaranteed. Relays are specified and tested in accordance with EN 61810-1. However, the standard makes no reference to EN 50178 (Electronic equipment for use in power installations); equally no definition is given for the term 'protective separation'. Things are made worse by the fact that different measurement conditions are given for the test voltages stipulated for relays.

As a consequence, the test voltages cannot be applied to the standards EN 50178 or EN 61140. And because the user is nevertheless increasingly deploying electrical equipment that is supposed to guarantee 'protective separation', a large number of manufacturers of relays point to the EN 61140 and carry out the tests accordingly. And of course the values are then 'protective separation' conform.

Standards

The following individual standards are applied in accordance with the corresponding requirements:

Relay couplers

- DIN EN 50178:
Electronic equipment for use in power installations

Relays

- DIN EN 61810-1:
Electromechanical elementary relays (electromechanical elementary relays without specified time response characteristics)
Part 1: General and safety requirements

Relay base

- DIN EN 61984
Connectors - Safety requirements and tests

EMC – Electromagnetic compatibility

DIN EN 61000-6-1

Part 6-1: Generic standards; Immunity for residential, commercial and light-industrial environments

DIN EN 61000-6-2

Part 6-2: Generic standards - Immunity for industrial environments

DIN EN 61000-6-3

Part 6-3: Generic standards - Emission standard for residential, commercial and light-industrial environments

DIN EN 61000-6-4

Part 6-4: Generic standards - Emission standard for industrial environments

Coil suppression circuit

In DC circuits, the inductance of the relay coil generates a release voltage when de-energised that is capable of damaging or destroying the connected control electronics. A free wheel diode connected in parallel to the coil limits the release voltage, protects the control electronics and prevents induction of the cut-off voltage to other signal lines.

Large circuits or long cable runs are subjected to increased electrical and electromechanical interference and damage. Malfunctions or even total failure of the relay module can result. The radiated interference, and not to forget leakage currents emanating from trigger modules, can also mean that a triggered relay does not drop out. As standards specify that the drop-out voltage is limited to about 15 percent of the rated voltage, the interference voltage generated can be sufficient to prevent the relay from opening. One way of resolving this problem is to connect an RC combination line side to filter out disturbances and provide capacitive suppression of interference voltages.

MICROSERIES products are supplied ex works with these protective circuits already integrated in the electronics; for the PLUGSERIES and RIDERSERIES these are available as modular series electronics.

The same principles apply as with contact protection circuits.

Relays – overview

C

Switching large and small capacities

Basically, the reliability of the contacts in a relay reaches a maximum at a medium current load thanks to the continuous self-cleaning effect. As the contact load increases and hence leads to more severe erosion of the contacts, the switching reliability decreases with an increasing number of switching operations. This reduces the service life of the contacts. Although at very low loads the minimal erosion of the contacts does raise the service life more or less to the level of the mechanical service life, the lack of a self-cleaning effect contributes to a lower contact reliability.

Reliable contact at low currents, especially when only small voltages are involved as well, depends on the choice of contact material. Contacts of silver-nickel, which is standard for the majority of Weidmüller relays, are generally suitable for currents of approx. 10 mA and higher. Such large-surface contacts can switch both low and high currents. However, at low currents occasional failures can occur due to erosion and the lack of the self-cleaning effect. The higher the current, the more reliable is the contact – thanks to the self-cleaning. Silver-nickel is suitable as a contact material for low currents/voltages. It provides, however, only **moderate switching reliability**. If this is acceptable, then conventional standard relays represent an inexpensive solution.

For applications that call for **improved contact reliability** or low currents/voltages, conventional relays with hard-plated gold contacts are preferable because they do not erode and therefore operate more reliably.

If **maximum switching reliability** is necessary, especially for low currents/voltages, a relay should not be your first choice. In these instances Weidmüller advises the use of optos. Wear and abrasion caused by mechanical movements are non-existent in optos.

Protective circuits for the contacts

The switching of inductive or capacitive loads produces switching sparks which can influence the electrical service life of the relays. The following protective circuits for the contacts reduce contact wear:

Diode

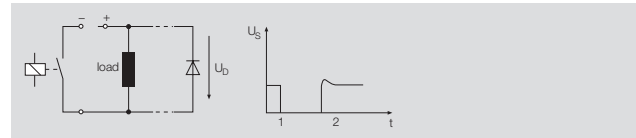

- Advantage: Can be used for all capacities, low surge, minimum space required, low price
 Disadvantage: Very long release delay

Diode and Z-diode

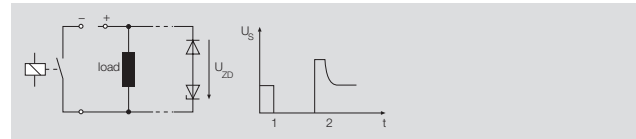

- Advantage: Low surge (defined by Z-diode), short release delay
 Disadvantage: Cannot be used for large capacities

Varistor

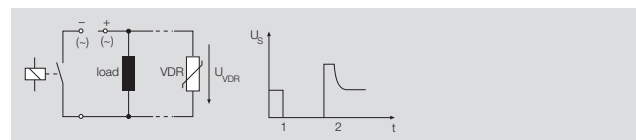

- Advantage: Low surge, short release delay
 Disadvantage: High current load on the contacts when switching on; more complicated and expensive at greater capacities

RC combination

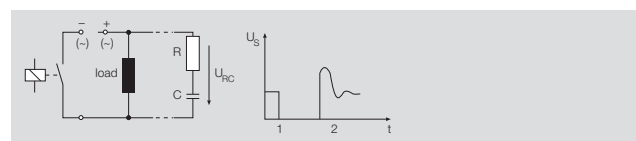

- Advantage: Short release delay, low price
 Disadvantage: Cannot be used for all operating voltages and capacities

U_s = Voltage progression 1 = Closing 2 = Opening

Principal characteristics of relay contacts

Although every relay contact has its own characteristics, the performance curves are very similar in terms of shape, but not in terms of the actual values. The examples below show curves for

- contact lifetime (number of make-break operations plotted against make-break capacity)
- DC limit curve (direct current plotted against direct voltage)
- reduction factor for inductive load (reduction factor plotted against $\cos \varphi$)

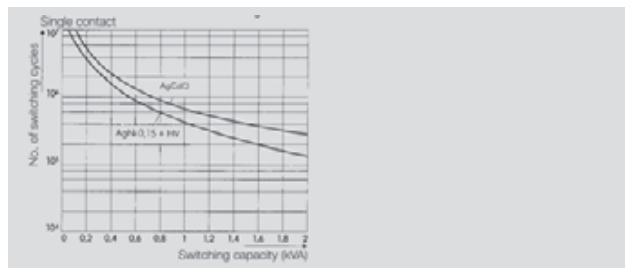

Contact lifetime for ohmic load

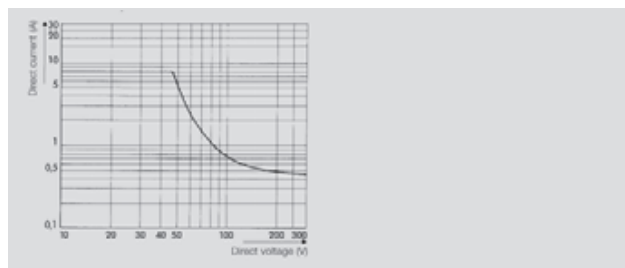

DC limit curve for ohmic load

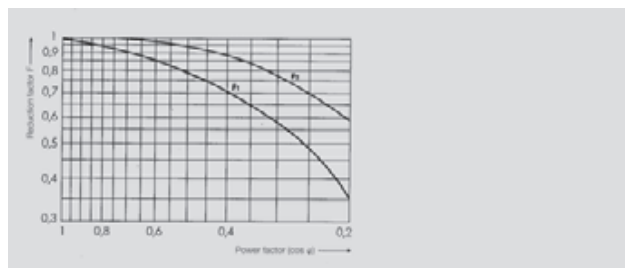

Reduction factor for inductive load $\cos \varphi < 1$
 Eff. make-break op. = make-break operations for $(\cos \varphi = 1) \times$

Derating curve

The transition resistance of the relay contacts is a key factor contributing to temperature increase inside the relay modules. This relationship is illustrated by a derating curve, defined as the function of the permissible current plotted against the ambient temperature.

The permissible current (curve a) is determined for the following operating conditions:

- Continuous operation
 - Rated input voltage + 10 percent
 - Several relay modules working under load, mounted horizontally in rows on mounting rail, without any spacing
- If the modules are mounted with a spacing > 20 mm, this results in a higher current load (curve b). Curve b also shows the maximum values for switching or short-time operation when mounted horizontally.

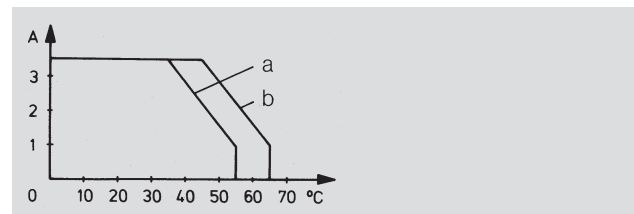

Relays – overview

Contact materials

AgNi Au (silver-nickel hard gold plated)

For dry loads, measuring and switching circuits, control inputs (1 mV – 10 V, 0.1 mA – 100 mA).

C

AgNi 0.15 (fine-grain silver)

Suitable for low to medium loads, AC and DC loads, resistive and inductive (solenoid valves, fans, heaters); not suitable for high inrush currents.

AgNi 90/10 (silver-nickel)

Suitable for all loads, constantly low contact-circuit resistances in the low load range, AC and DC loads, resistive and inductive (solenoid valves, fans, heaters); not suitable for capacitive inrush currents.

AgSnO₂ 90/10 (silver-tin oxide)

Suitable for all loads. Well suited to higher loads. Particularly well suited to high inrush currents with short rise times (lamp loads, capacitive loads, fluorescent tubes, switch-mode power supplies, etc.). Well suited to resistive, inductive and capacitive DC applications due to low material transport.

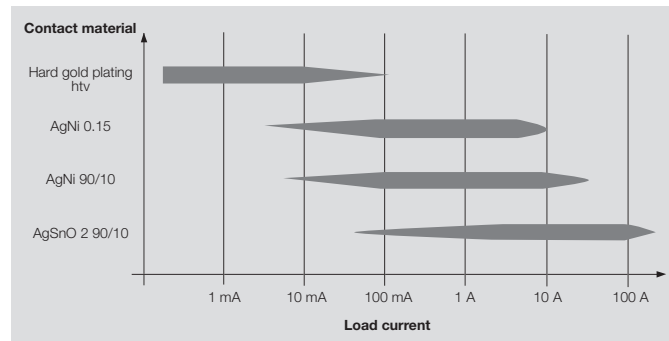

Definition of technical data

Input Circuit	
Nominal voltage [V]	Reference voltage at which the relays operates; typical input voltages = > 5 V DC, 12, 24, 48, 60, 115, 230 AC/DC
Nominal current [mA]	Input voltage and input resistance; input resistance = > coil resistance + resistance of triggering device (R, LED, GL ...)
Nominal power [W/VA]	Input voltage x input current DC/AC with tolerance $\pm 10\%$ or $+5/-15\%$, typical range for relays 250 mW ... 1 W or 0.4 VA ... 1.2 VA
Response voltage [V]	Smallest input voltage required for the relays to respond ($T_u = 293\text{ K}$)
Pick-up current [mA]	Smallest input current at which the relay switches from normal to operating position ($T_u = 293\text{ K}$)
Pick-up power [W/VA]	Product of response voltage and pick-up current
Drop-out voltage [V]	Voltage level at which the relay reliably drops out
Drop-out current [mA]	Input current at which the relay reliably drops out
Output Circuit	
Max. switching voltage [V]	Max. voltage that can be applied to the relay contact
Making current [A]	The current allowed to flow for max. 4 seconds after the relay contact closes
Continuous current [A]	Current allowed to flow continuously after the contact closes
Switching power [W/VA]	Product of output voltage and making current for resistive, inductive or capacitive load
Min. switching power [μW]	Smallest power that can be switched via the contact
Service life	Number of switching operations until the contact fails – mechanical = > without electrical load – electrical = > under resistive or inductive AC/DC load
Response time [ms]	Time until contact closes/opens after switching the excitation voltage
Drop-out time [ms]	Time until contact closes/opens after opening the excitation current circuit
Switching frequency [Hz]	Switching operations per second in pulse duty factor 1 : 2 ($t_{on} = t_{off}$)
Dielectric strength [kV]	Max. test voltage between input and output circuits that does not result in a discharge
Protective separation	Relays to EN 50178 and VDE 0106 part 101

Relays - DK-SERIES

1 NO contact
input bottom
DC/UC coil

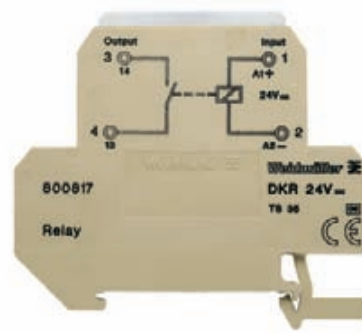

C

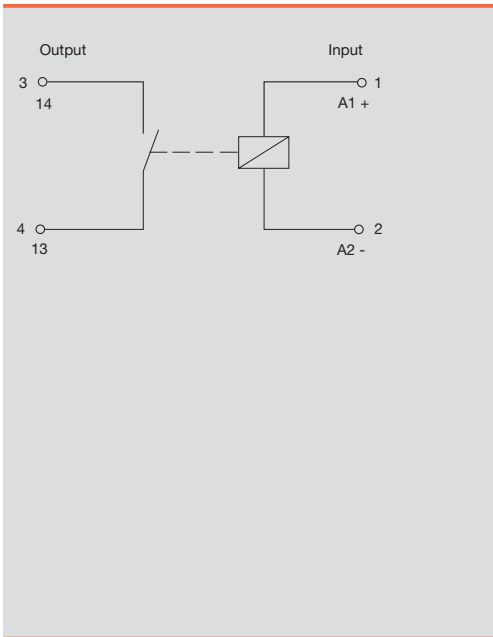

Output	
max. switching voltage AC1/Continuous current	100 V/0.5 A
min. switching power	1 V / 1 mA
Response time / Drop-out time	typically 0.7...2.5 ms/0.2...2 ms
Contact base material	Rh/Ru
Mechanical endurance	10 ⁹ switching cycles
max. switching frequency at rated load	200.0 Hz
Rated data	
Status indicator/Free wheel diode	green LED/Yes
Reverse pol. prot	available
Ambient temperature (operational)	-25 °C...+40 °C
Storage temperature	-40 °C...+60 °C
Humidity	40°C/93% RH, no condensation
Approvals	CE;
Insulation coordination (EN 50178)	
Standards	EN 50178
Rated voltage	150 V
Impulse withstand voltage	1.5 kV
Clearance and creepage distances for control/load side	≥ 3 mm
Surge category	III
Pollution severity	2
Protective separation to VDE 0106 part 101	no
Dimensions	
Clamping range (rating- / min. / max.)	mm ² 4 / 0.5 / 4
Length x width x height	mm 77 / 6 / 62
Note	
	End plate AP DKT4 0687560000

Ordering data	5 V DC 1NO	12 V DC 1NO	24 V UC 1NO	24 V DC 1NO
Input				
Rated voltage	5 V DC ±5%	12 V DC ±10 %	24 V UC ±10 %	24 V DC +5% / -10%
Rated current AC			15 mA	
Rated current DC	12.5mA	12 mA	9 mA	9.3 mA
Power rating	65 mW	144 mW	0,36 VA / 216 mW	225 mW
AC Response/dropout Volt			12 V / 8 V	
DC Response/dropout Volt	4.4 V	9 V	11 V / 10 V	11 V
AC pickup/dropout current			6,3 mA / 4,3 mA	
DC pickup/dropout current	11.8 mA	10 mA	3,8 mA / 3 mA	7.5 mA
Ordering data				
For TS 32	Type		DKR 32 24VUC 1A	DKR 32 24VDC 1A
	Order No.		8008110000	8016620000
For TS 35	Type	DKR 35 5VDC 1A	DKR 35 12VDC 1A	DKR 35 24VUC 1A
	Order No.	8019610000	8171100000	8008170000
Ordering data				
	Type			
	Order No.			
Note				

1 change-over contact
input bottom DC coil

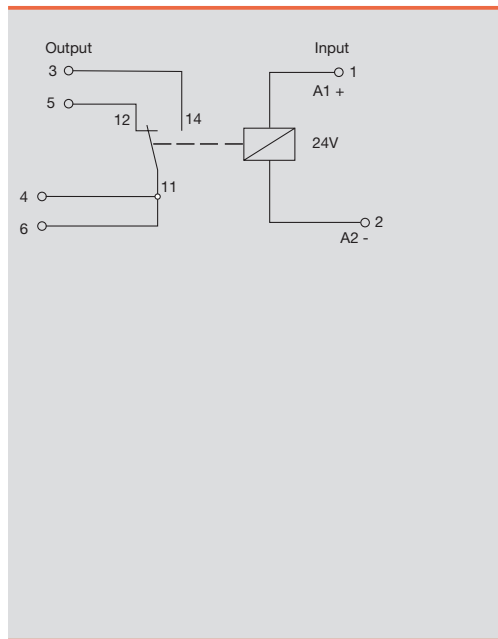
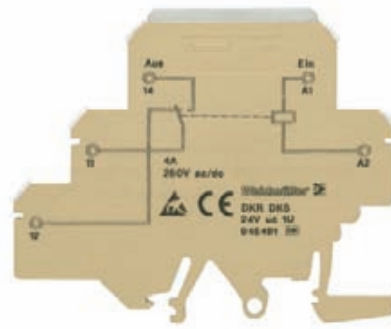

Output	
max. switching voltage AC1/Continuous current	250 V/6 A
min. switching power	5 V / 10 mA
Response time / Drop-out time	6 ms/15 ms AC;8 ms DC
Contact base material	AgSnO2
Mechanical endurance	2*10 ⁷ switching cycles
max. switching frequency at rated load	0.1 Hz
Rated data	
Status indicator/Free wheel diode	green LED/Yes
Reverse pol. prot	not available
Ambient temperature (operational)	-40 °C...+60 °C
Storage temperature	-40 °C...+60 °C
Humidity	40°C/93% RH, no condensation
Approvals	CE;
Insulation coordination (EN 50178)	
Standards	EN 50178
Rated voltage	300 V
Impulse withstand voltage	4 kV
Clearance and creepage distances for control/load side	≥ 8 mm
Surge category	III
Pollution severity	2
Protective separation to VDE 0106 part 101	no
Dimensions	
Clamping range (rating- / min. / max.)	mm ² 4 / 0.5 / 4
Length x width x height	mm 77 / 6 / 62
Note	
End plate AP DK5: 8268870000; AP DKT4: 0687560000	

C

Ordering data

Input	
Rated voltage	24 V DC ±20 %
Rated current AC	9 mA
Rated current DC	7mA
Power rating	220 mVA/ 180 mW
AC Response/dropout Volt	18 V
DC Response/dropout Volt	19 V
AC pickup/dropout current	7 mA
DC pickup/dropout current	5.5 mA

24 V UC 1CO			
-------------	--	--	--

Ordering data

For TS 32	Type	DKR DK5 24VUC 1U
	Order No.	9454910000
For TS 35	Type	DKR DK5 24VUC 1U
	Order No.	9454910000

Ordering data

	Type	
	Order No.	

Note

--

Relays - DK-SERIES

**1 change-over contact
input bottom DC/UC coil**



C

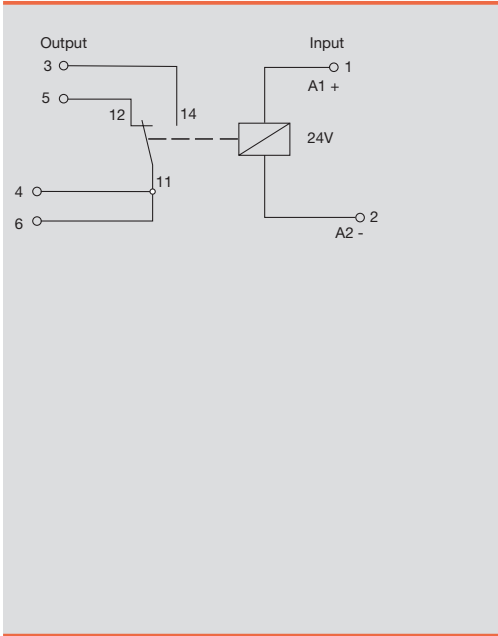

Output				
max. switching voltage AC1/Continuous current	250 V/6 A			
min. switching power	10 V / 100 mA			
Response time / Drop-out time	typically 0.7...2.5 ms/0.2...2 ms			
Contact base material	AgNi 0.15 gold flashed			
Mechanical endurance	≥10 ⁷ switching cycles			
max. switching frequency at rated load	10.0 Hz			
Rated data				
Status indicator/Free wheel diode	green LED/Yes			
Reverse pol. prot	available			
Ambient temperature (operational)	-25 °C...+40 °C			
Storage temperature	-40 °C...+60 °C			
Humidity	40°C/93% RH, no condensation			
Approvals	CE;			
Insulation coordination (EN 50178)				
Standards	EN 50178			
Rated voltage	300 V			
Impulse withstand voltage	6 kV			
Clearance and creepage distances for control/load side	≥ 8 mm			
Surge category	IV			
Pollution severity	2			
Protective separation to VDE 0106 part 101	no			
Dimensions				
Clamping range (rating- / min. / max.)	mm ²	4 / 0.5 / 4	Screw connection	Tension clamp connection
Length x width x height	mm	65 / 18 / 62		
Note		End plate AP DKT4 0687560000		

Ordering data	24 V DC 1CO	24 V UC 1CO		
Input				
Rated voltage	24 V DC ±20 %	24 V DC ±20 %		
Rated current AC		20 mA		
Rated current DC	11.5 mA	16 mA		
Power rating	384 mW	480 mW / 400 mW		
AC Response/dropout Volt		18 V		
DC Response/dropout Volt	19 V	18 V		
AC pickup/dropout current		12.8 mA		
DC pickup/dropout current	9 mA	11.5 mA		
Ordering data				
For TS 32	Type			
	Order No.			
For TS 35	Type	DKR 35 24VDC 1U	DKR 35 24VUC 1U	
	Order No.	8181980000	8181970000	
Ordering data				
	Type			
	Order No.			
Note				

Relays - MCZ SERIES

**Mini-conditioner MCZ R
1 change-over contact
AC/ DC/ UC coil**

Module can be used as an universal interface between control and actuator to switch small and medium-sized loads.

- 1 change-over contact
- Pluggable cross-connection at input and output minimises the wiring workload.
- 6 mm wide, low height



Output			
max. switching voltage AC1/Continuous current	250 V/6 A		
min. switching power	12 V / 100 mA		
Response time / Drop-out time	4.5 ms/10 ms		
Contact base material	AgSnO2		
Mechanical endurance	20*10 ⁶ switching cycles		
max. switching frequency at rated load	0.1 Hz		
Rated data			
Status indicator/Free wheel diode	green LED/Yes		
Reverse pol. prot	available		
Ambient temperature (operational)	-25 °C...+ 55 °C		
Storage temperature	-40 °C...+60 °C		
Humidity	40°C/93% RH, no condensation		
Approvals	CSA;cURus;CE;GL;		
Insulation coordination (EN 50178)			
Standards	EN 50178		
Rated voltage	300 V		
Impulse withstand voltage	6 kV		
Clearance and creepage distances for control/load side	≥ 5.5 mm		
Surge category	III		
Pollution severity	2		
Protective separation to VDE 0106 part 101	Yes		
Dimensions			
Clamping range (rating- / min. / max.)	mm ²	Screw connection	Tension clamp connection
Length x width x height	mm		
			1.5 / 0.5 / 2.5
			91 / 6 / 63.2
Note		End plate AP MCZ 1.5: 8389030000 for cross-connectors and markers - refer to MCZ Series accessories	

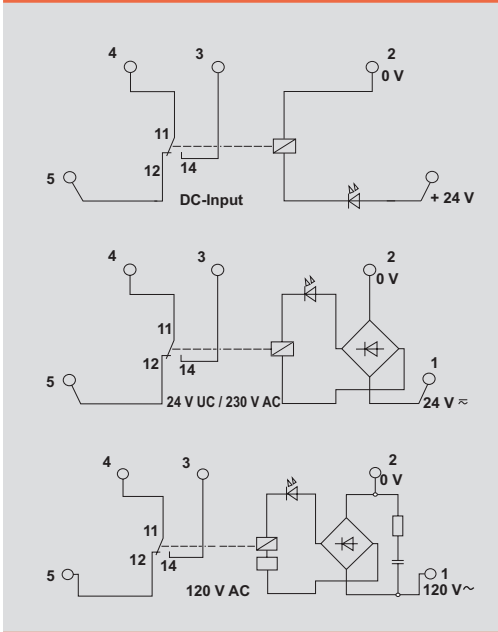

Applications

Limit curve

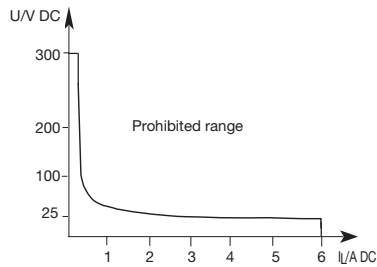

Derating curve

— in a row without spacing on terminal rail
- - - in a row with 20 mm spacing on terminal rail

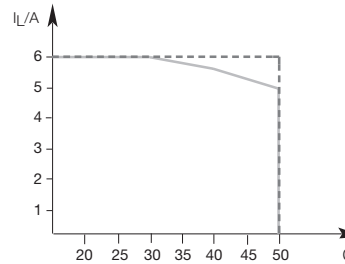

Mini-conditioner MCZ R 1 change-over contact AC/ DC/ UC coil

Ordering data	24 V DC 1CO	24 V DC 1CO Au	24 V UC 1CO	60 V DC 1CO
Input				
Rated voltage	24 V DC $\pm 20\%$	24 V DC $\pm 20\%$	24 V UC $\pm 10\%$	5 V DC $\pm 20\%$
Rated current AC			10.8 mA	
Rated current DC	6.3 mA	6.3 mA	6.1 mA	3 mA
Power rating	156 mW	156 mW	160 mVA / 150 mW	180 mW
AC Response/dropout Volt			approx. 17 V/ approx. 7 V	
DC Response/dropout Volt	12 V...19 V/4 V...5.5 V	12 V...19 V/4 V...5.5 V	approx. 19 V/ approx. 4 V	approx. 38 V/ approx. 14 V
AC pickup/dropout current				
DC pickup/dropout current	5.7 mA	5.7 mA	9 mA / 5 mA	2.7 mA
Ordering data Complete module				
CO contact Type	MCZ R 24VDC	MCZ R 24VDC 5uAu	MCZ R 24VUC	MCZ R 60VDC
Order No.	8365980000	8442960000	8390590000	8470380000
NO contact Type				
Order No.				
Ordering data Spare relay				
Type				
Order No.				
Note		Safely switches loads of: 1...60 V AC/DC, 1...3 mA. The gold layer may be destroyed by switching greater voltages.		
Ordering data	110 V DC 1CO	120 V AC 1CO	230 V AC 1CO	
Input				
Rated voltage	110 V DC $\pm 10\%$	120 V AC -15 %/ +10 %	230 V AC $\pm 10\%$	
Rated current AC		7 mA	9.5 mA	
Rated current DC	2.85 mA			
Power rating	340 mW	0.85 VA	2.1 VA	
AC Response/dropout Volt		approx. 70 V/ approx. 22 V	approx. 115 V/ approx. 60 V	
DC Response/dropout Volt	approx. 68 V/ approx. 19 V			
AC pickup/dropout current		4 mA / 1.3 mA	5 mA / 2.5 mA	
DC pickup/dropout current	1.6 mA/0.4 mA			
Ordering data Complete module				
CO contact Type	MCZ R 110VDC	MCZ R 120VAC	MCZ R 230VAC	
Order No.	8467470000	8420880000	8237710000	
NO contact Type				
Order No.				
Ordering data Spare relay				
Type				
Order No.				
Note				

C

Relays - MCZ-TRAK-SERIES

MCZ R TRAK
1 CO contact or 1 NO contact
DC coil

- 1 CO contact
- Module for rail industry applications
- Vibration requirements according to EN 61373, requirements category 1 class B
- Voltage fluctuations -30%/+25% and ±40% for 0.1 sec
- Voltage interruptions at input up to 10 ms
- Condensation permissible



C

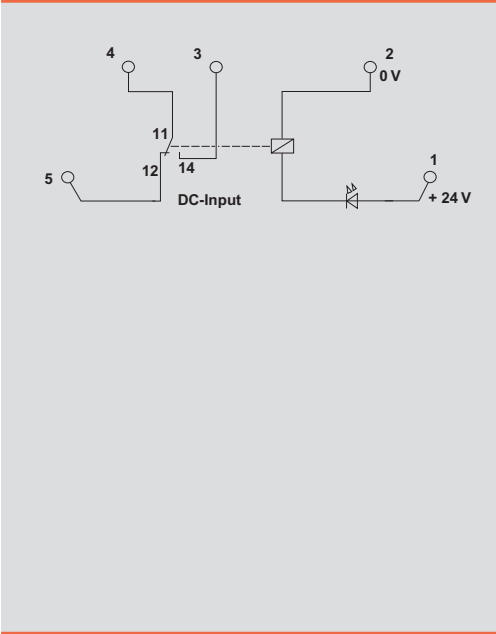

Output			
max. switching voltage AC1/Continuous current	250 V/6 A		
min. switching power	12 V / 100 mA		
Response time / Drop-out time	< 6,5 ms / < 75 ms		
Contact base material	AgSnO		
Mechanical endurance	20*10 ⁶ switching cycles		
max. switching frequency at rated load	0.1 Hz		
Rated data			
Status indicator/Free wheel diode	green LED/Yes		
Reverse pol. prot	available		
Ambient temperature (operational)	+85°C for 10 minutes; -25 °C...+70 °C		
Storage temperature	-40 °C...+85 °C		
Humidity	95% for 30 days, minimal condensation to EN 50155		
Approvals	CE;		
Insulation coordination (EN 50178)			
Standards	EN 50178		
Rated voltage	300 V		
Impulse withstand voltage	4 kV (1.2/50 µs)		
Clearance and creepage distances for control/load side	≥ 5.5 mm		
Surge category	III		
Pollution severity	2		
Protective separation to VDE 0106 part 101	Yes		
Dimensions			
Clamping range (rating- / min. / max.)	mm ²	Screw connection	Tension clamp connection
Length x width x height	mm		
		1.5 / 0.5 / 2.5	91 / 6 / 63.2
Note		End plate AP MCZ 1.5: 8389030000 for cross-connectors and markers - refer to MCZ Series accessories	

Applications

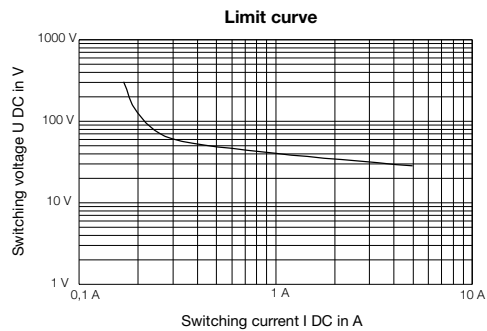
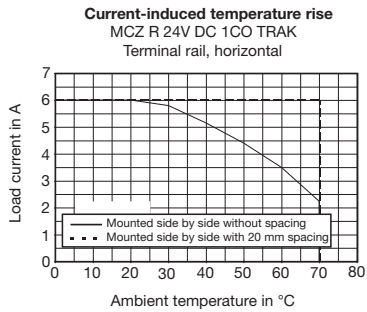

MCZ R TRAK
1 CO contact or 1 NO contact
DC coil

C

Ordering data		24 V DC TRAK	36 V DC TRAK	48...110 V DC TRAK	
Input					
Rated voltage		24 V DC	36 V DC	48...110 V DC TRAK	
Rated current AC					
Rated current DC		11.5...16.5 V	8...12 mA	< 3 mA	
Power rating		195...50 mW	200...540 mW	< 300 mW	
AC Response/dropout Volt					
DC Response/dropout Volt		7...14 V / 3...5 V	4.5...15 V	> 25 V / < 6 V	
AC pickup/dropout current					
DC pickup/dropout current					
Ordering data Complete module					
CO contact	Type	MCZ R 24Vdc 1CO TRAK	MCZ R 36Vdc 1CO TRAK	MCZ R 48...110Vdc 1CO TRAK	
	Order No.	8713890000	8713900000	8713910000	
NO contact	Type	MCZ R 24Vdc 1NO TRAK	MCZ R 36Vdc 1NO TRAK	MCZ R 48...110Vdc 1NO TRAK	
	Order No.	8499550000	8582130000	8574070000	
Ordering data Spare relay					
	Type				
	Order No.				
Note					
Ordering data					
Input					
Rated voltage					
Rated current AC					
Rated current DC					
Power rating					
AC Response/dropout Volt					
DC Response/dropout Volt					
AC pickup/dropout current					
DC pickup/dropout current					
Ordering data Complete module					
CO contact	Type				
	Order No.				
NO contact	Type				
	Order No.				
Ordering data Spare relay					
	Type				
	Order No.				
Note					

Relays - MCZ-TRAK-SERIES

MCZ R TRAK Au
1 CO contact or 1 NO contact
DC coil

- 1 CO with hard gold-plated contacts
- Module for rail industry applications
- Vibration requirements according to EN 61373, requirements category 1 class B
- Voltage fluctuations -30%/+25% and ±40% for 0.1 sec
- Voltage interruptions at input up to 10 ms
- Condensation permissible



C

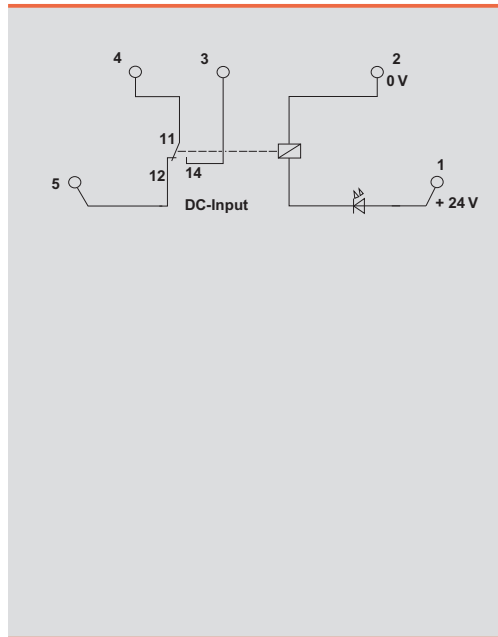

Output			
max. switching voltage AC1/Continuous current	/6 A		
min. switching power	1 V / 1 mA		
Response time / Drop-out time	< 6,5 ms / < 75 ms		
Contact base material	AgSnO 5µm Au		
Mechanical endurance	20*10 ⁶ switching cycles		
max. switching frequency at rated load	0.1 Hz		
Rated data			
Status indicator/Free wheel diode	green LED/		
Reverse pol. prot			
Ambient temperature (operational)	+85°C for 10 minutes; 25 °C...+70 °C		
Storage temperature	-40 °C...+85 °C		
Humidity	95% for 30 days, minimal condensation to EN 50155		
Approvals	CE;		
Insulation coordination (EN 50178)			
Standards			
Rated voltage	300 V		
Impulse withstand voltage	4 kV (1.2/50 µs)		
Clearance and creepage distances for control/load side			
Surge category	III		
Pollution severity	2		
Protective separation to VDE 0106 part 101	Yes		
Dimensions			
Clamping range (rating- / min. / max.)	mm ²	Screw connection	Tension clamp connection
		1.5 / 0.5 / 2.5	
Length x width x height	mm	91 / 6 / 63.2	
Note			
End plate AP MCZ 1.5: 8389030000 for cross-connectors and markers - refer to MCZ Series accessories			

Applications

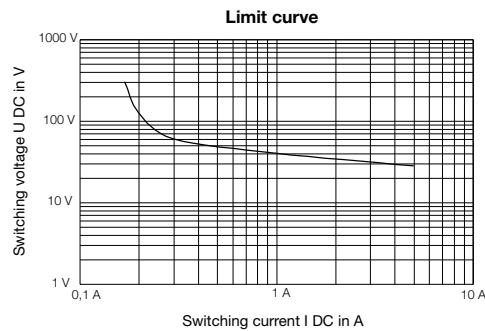
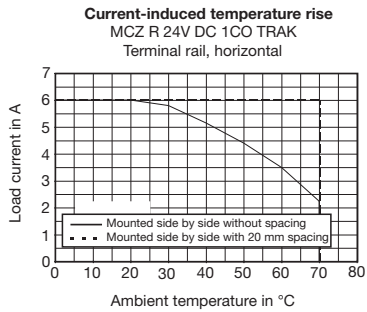

MCZ R TRAK Au
1 CO contact or 1 NO contact
DC coil

C

Ordering data		24 V DC TRAK Au	36 V DC TRAK Au	48...110 V DC TRAK Au	
Input					
Rated voltage		24 V DC	36 V DC	48...110 V DC TRAK	
Rated current AC					
Rated current DC		11.5...16.5 mA	8...12 mA	< 3 mA	
Power rating		195...50 mW	200...540 mW	< 300 mW	
AC Response/dropout Volt					
DC Response/dropout Volt		7...14 V / 3...5 V	4.5...15 V	> 25 V / < 6 V	
AC pickup/dropout current					
DC pickup/dropout current					
Ordering data Complete module					
CO contact	Type	MCZ R 24VDC 1CO AU TRAK	MCZ R 36VDC 1CO AU TRAK	MCZ R 48...110VDC 1CO AU	
	Order No.	8790520000	8790510000	8790500000	
NO contact	Type				
	Order No.				
Ordering data Spare relay					
	Type				
	Order No.				
Note					
		Safely switches loads of: 1...60 V AC/DC, 1...300 mA. The gold layer may be destroyed by switching greater voltages.	Safely switches loads of: 1...60 V AC/DC, 1...300 mA. The gold layer may be destroyed by switching greater voltages.	Safely switches loads of: 1...60 V AC/DC, 1...300 mA. The gold layer may be destroyed by switching greater voltages.	
Ordering data					
Input					
Rated voltage					
Rated current AC					
Rated current DC					
Power rating					
AC Response/dropout Volt					
DC Response/dropout Volt					
AC pickup/dropout current					
DC pickup/dropout current					
Ordering data Complete module					
CO contact	Type				
	Order No.				
NO contact	Type				
	Order No.				
Ordering data Spare relay					
	Type				
	Order No.				
Note					

Relays – MCZ-SERIES accessories

MCZ accessories

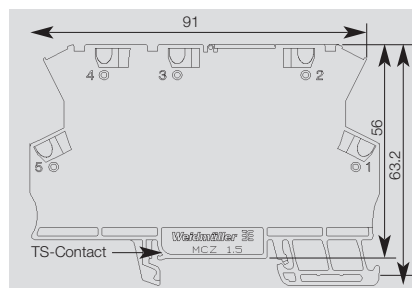

Ordering data

Type	Qty	Order No.
End plate	50	8389030000

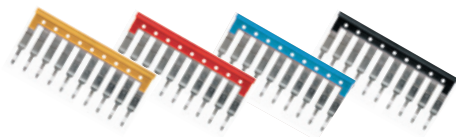

Ordering data

	No. of poles	Type	Qty	Order No.
Plug-in cross-connection, yellow	2	ZQV 4N / 2 GE	60	1758250000
Plug-in cross-connection, yellow	3	ZQV 4N / 3 GE	60	1762630000
Plug-in cross-connection, yellow	4	ZQV 4N / 4 GE	60	1762620000
Plug-in cross-connection, yellow	10	ZQV 4N / 10 GE	20	1758260000
Plug-in cross-connection, yellow	20	ZQV 4N / 20 GE	20	1909020000
Plug-in cross-connection, red	2	ZQV 4N / 2 RT	60	1793950000
Plug-in cross-connection, red	3	ZQV 4N / 3 RT	60	1793980000
Plug-in cross-connection, red	4	ZQV 4N / 4 RT	60	1794010000
Plug-in cross-connection, red	10	ZQV 4N / 10 RT	20	1794040000
Plug-in cross-connection, red	20	ZQV 4N / 20 RT	20	1909150000
Plug-in cross-connection, blue	2	ZQV 4N / 2 BL	60	1793960000
Plug-in cross-connection, blue	3	ZQV 4N / 3 BL	60	1793990000
Plug-in cross-connection, blue	4	ZQV 4N / 4 BL	60	1794020000
Plug-in cross-connection, blue	10	ZQV 4N / 10 BL	20	1794050000
Plug-in cross-connection, blue	20	ZQV 4N / 20 BL	20	1909100000
Plug-in cross-connection, black	2	ZQV 4N / 2 SW	60	1793970000
Plug-in cross-connection, black	3	ZQV 4N / 3 SW	60	1794000000
Plug-in cross-connection, black	4	ZQV 4N / 4 SW	60	1794030000
Plug-in cross-connection, black	10	ZQV 4N / 10 SW	20	1794060000
Plug-in cross-connection, black	20	ZQV 4N / 20 SW	20	1909120000

Ordering data

Type	Qty	Order No.
Marker	200	1060960000

Relays - MICROSERIES

1 change-over contact AC/DC/UC coil

Module can be used as an universal interface between the controller and the actuator to switch small and medium-sized loads.

- Relay modul interchangeable, also for an opto modul
- 6.1 mm wide
- Pluggable cross-connection at input and output minimises the wiring workload.

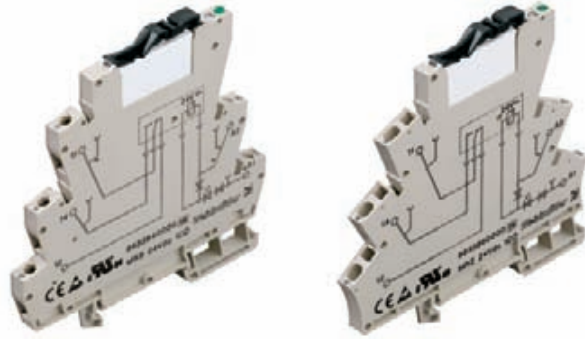

C

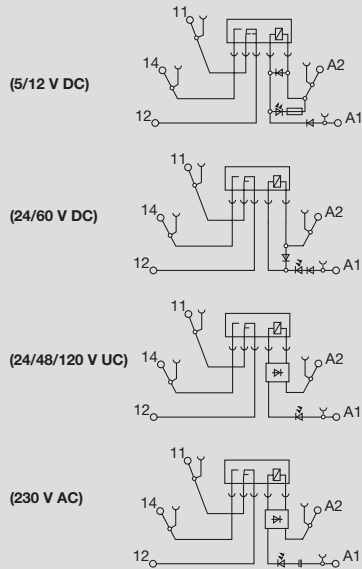

Output			
max. switching voltage AC1/Continuous current	250 V/6 A		
min. switching power	12 V / 100 mA		
Response time / Drop-out time	6.2ms/3.9ms		
Contact base material	AgSnO		
Mechanical endurance	20*10 ⁶ switching cycles		
max. switching frequency at rated load	0.1 Hz		
Rated data			
Status indicator/Free wheel diode	green LED/Yes		
Reverse pol. prot	available		
Ambient temperature (operational)	-25 °C...+50 °C		
Storage temperature	-40 °C...+60 °C		
Humidity	40°C/93% RH, no condensation		
Approvals	CE; cULus;		
Insulation coordination (EN 50178)			
Standards	EN 50178		
Rated voltage	300 V		
Impulse withstand voltage	4 kV		
Clearance and creepage distances for control/load side	≥ 5.5 mm		
Surge category	III		
Pollution severity	2		
Protective separation to VDE 0106 part 101	Yes		
Dimensions			
Clamping range (rating- / min. / max.)	mm ²	Screw connection	Tension clamp connection
		2.5 / 0.5 / 4	1.5 / 0.5 / 2.5
Length x width x height	mm	93 / 6.1 / 92	94 / 6.1 / 91
Note	Cross-connectors and markers - refer to MICROSERIES accessories		

Applications

Limit curve

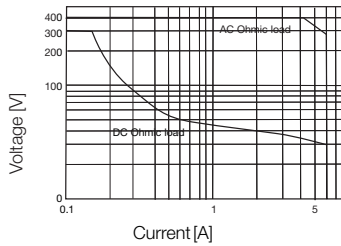

Current-Temperature rise curve

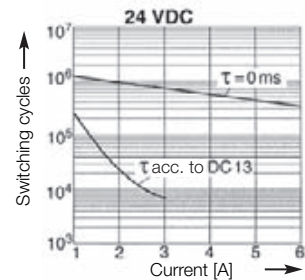
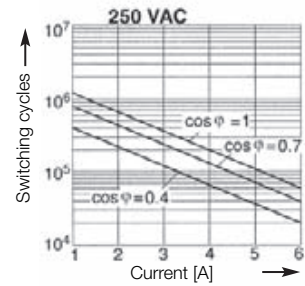
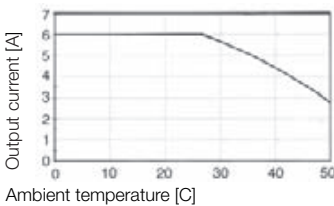

1 change-over contact AC/DC/UC coil

C

Ordering data	5 V DC 1CO	12 VDC 1CO	24 V DC 1CO	24 V UC 1CO
Input				
Rated voltage	5 V DC ±20%	12 V DC ±20%	24 V DC ±20 %	24 V UC ±10 %
Rated current AC				11 mA
Rated current DC	38.5 mA	17 mA	6.6mA	6.4 mA
Power rating	193 mW	210 mW	160 mW	154 mW
AC Response/dropout Volt				15.8V/7V
DC Response/dropout Volt	3.2V/1.6V	6.4V/ 2.5V	15.4V/6.5V	15.8V/7V
AC pickup/dropout current				3.6mA/1.3mA
DC pickup/dropout current	21.6mA/8mA	8.4mA/2.4mA	4mA/1.2mA	3.6mA/1.3mA
Ordering data Relay with socket				
Screw connection Type	MRS 5Vdc 1CO	MRS 12Vdc 1CO	MRS 24Vdc 1CO	MRS 24Vuc 1CO
Order No.	8556080000	8556070000	8533640000	8556050000
Tension spring connection Type	MRZ 5Vdc 1CO	MRZ 12Vdc 1CO	MRZ 24VDC 1CO	MRZ 24Vuc 1CO
Order No.	8556150000	8556140000	8533660000	8556120000
Ordering data Spare relay (pluggable)				
Type	RSS113005 05Vdc-Rel1U	RSS113012 12Vdc-Rel1U	RSS113024 24Vdc-Rel1U	RSS113024 24Vdc-Rel1U
Order No.	4061580000	4061610000	4060120000	4060120000
Note				
Ordering data	48 V UC 1CO	60 V DC 1CO	120 V UC 1CO	230 V AC 1CO
Input				
Rated voltage	48 V UC ±10 %	5 V DC ±20%	120 V UC + 10 %/ -15 %	230 V AC ±10%
Rated current AC	5 mA		3.5 mA	7.6 mA
Rated current DC	4 mA	3.3 mA	3.5 mA	
Power rating	190 mW	200 mW	0.42 VA	1.75 VA
AC Response/dropout Volt	29V/11V		71V/22V	103V/49V
DC Response/dropout Volt	29V/11V	35V/11V	71V/22V	
AC pickup/dropout current	2.2mA/1.3mA		1.8mA/0.5mA	5mA/2.5mA
DC pickup/dropout current	2.2mA/1.3mA	1.6mA/0.6mA	1.8mA/0.5mA	
Ordering data Relay with socket				
Screw connection Type	MRS 48Vuc 1CO	MRS 60Vdc 1CO	MRS 120Vuc 1CO	MRS 230Vac 1CO
Order No.	8556040000	8556060000	8556030000	8556020000
Tension spring connection Type	MRZ 48Vuc 1CO	MRZ 60Vdc 1CO	MRZ 120Vuc 1CO	MRZ 230Vac 1CO
Order No.	8556110000	8556130000	8556100000	8556090000
Ordering data Spare relay (pluggable)				
Type	RSS113048 48Vdc-Rel1U	RSS113060 60Vdc-Rel1U	RSS113060 60Vdc-Rel1U	RSS113024 24Vdc-Rel1U
Order No.	4061620000	4061630000	4061630000	4060120000
Note				

Relays - MICROSERIES

1 NO contact special versions

- 24 VDC actuator version:
Bridgeable, potential-free connection for direct connection of actuators at the output
- 120 VAC RC version:
RC circuit at the input guarantees safe switching thresholds, e.g. for leakage currents on the control side
- 230 V UC version:
Can also be interconnected at input with DC signals

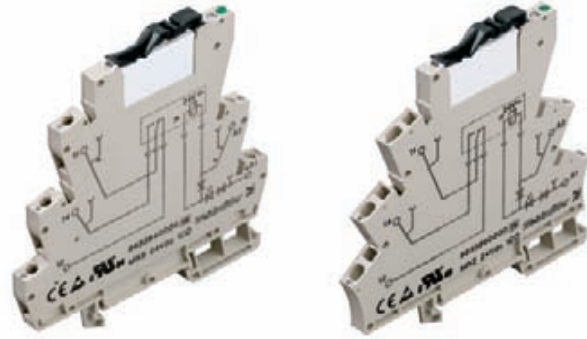

C

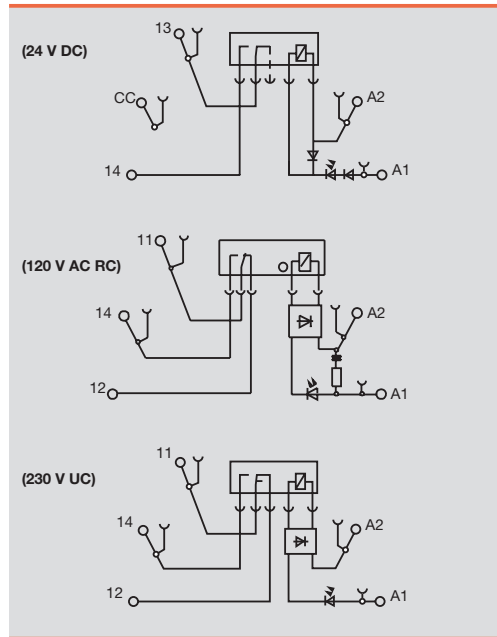

Output			
max. switching voltage AC1/Continuous current	250 V/6 A		
min. switching power	12 V / 100 mA		
Response time / Drop-out time	6.6 ms/5.8 ms		
Contact base material	AgSnO		
Mechanical endurance	20*10 ⁶ switching cycles		
max. switching frequency at rated load	0.1 Hz		
Rated data			
Status indicator/Free wheel diode	green LED/Yes		
Reverse pol. prot	available		
Ambient temperature (operational)	-25 °C...+ 55 °C		
Storage temperature	-40 °C...+60 °C		
Humidity	40°C/93% RH, no condensation		
Approvals	CE; cULus;		
Insulation coordination (EN 50178)			
Standards	EN 50178		
Rated voltage	300 V		
Impulse withstand voltage	4 kV (1.2/50 µs)		
Clearance and creepage distances for control/load side	≥ 5.5 mm		
Surge category	III		
Pollution severity	2		
Protective separation to VDE 0106 part 101			
Dimensions			
Clamping range (rating- / min. / max.)	mm ²	Screw connection	Tension clamp connection
		2.5 / 0.5 / 4	1.5 / 0.5 / 2.5
Length x width x height	mm	93 / 6.1 / 92	94 / 6.1 / 91
Note	Cross-connectors and markers - refer to MICROSERIES accessories		

Ordering data

	24 V DC ACT	120 V AC 1CO RC	230 V UC 1CO	
Input				
Rated voltage	24 V DC ±20 %	120 V AC + 10 %/ -15 %	230 V UC +10 % / -15 %	
Rated current AC		7 mA	3.5 mA	
Rated current DC	6.6 mA		2.9 mA	
Power rating	160 mW	0.84 VA	0.8 VA / 660 mW	
AC Response/dropout Volt		79 V / 65 V	146 V / 124 V	
DC Response/dropout Volt	15,4 V / 6,5 V		155 V / 115 V	
AC pickup/dropout current		4.5 mA / 3.7 mA	1.9 mA / 1.5 mA	
DC pickup/dropout current	4 mA / 1,2 mA		1.9 mA / 1.0 mA	
Ordering data Complete module				
Screw connection Type	MRS 24Vdc ACT	MRS 120VUC 1CO RC	MRS 230VUC 1CO	
Order No.	8660920000	8825970000	8825990000	
Tension clamp connection Type	MRZ 24Vdc ACT	MRZ 120VUC 1CO RC	MRZ 230VUC 1CO	
Order No.	8660910000	8825960000	8825980000	
Ordering data Spare relay, pluggable				
Type	RSS113024 24Vdc-Rel1U	RSS113060 60Vdc-Rel1U	RSS113060 60Vdc-Rel1U	
Order No.	4060120000	4061630000	4061630000	
Note				

1 change-over contact with gold-plated contact AC/DC/UC coil

Module can be used as an universal interface between the controller and the actuator to switch small and medium-sized loads.

- Relay modul interchangeable, also for an opto modul
- 6.1 mm wide
- Pluggable cross-connection at input and output minimises the wiring workload.

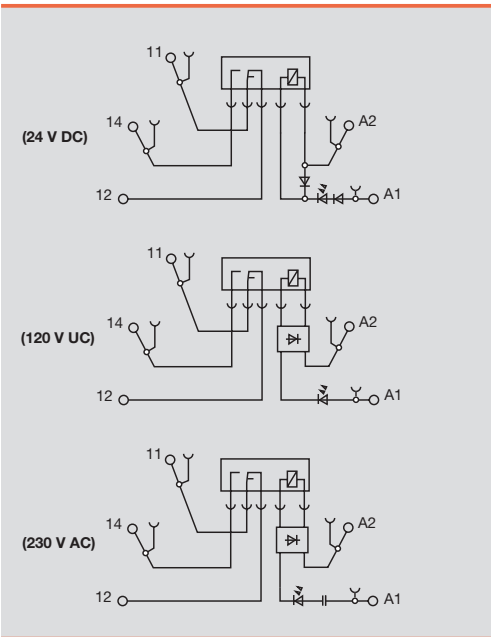
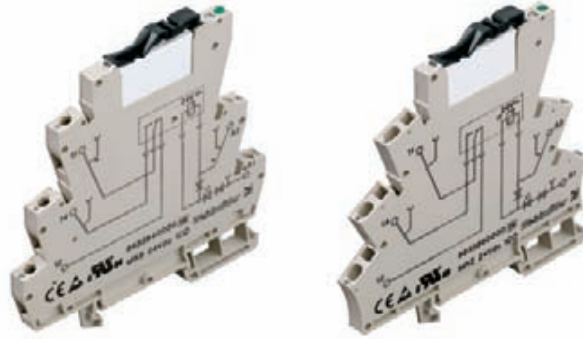

Output			
max. switching voltage AC1/Continuous current	250 V/6 A		
min. switching power	1 V / 1 mA		
Response time / Drop-out time	6.8ms/5.8ms		
Contact base material	AgSnO 5µm Au		
Mechanical endurance	20*10 ⁶ switching cycles		
max. switching frequency at rated load	0.1 Hz		
Rated data			
Status indicator/Free wheel diode	green LED/Yes		
Reverse pol. prot	available		
Ambient temperature (operational)	-25 °C...+50 °C		
Storage temperature	-40 °C...+60 °C		
Humidity	40°C/93% RH, no condensation		
Approvals	CE; cULus;		
Insulation coordination (EN 50178)			
Standards	EN 50178		
Rated voltage	300 V		
Impulse withstand voltage	4 kV		
Clearance and creepage distances for control/load side	≥ 5.5 mm		
Surge category	III		
Pollution severity	2		
Protective separation to VDE 0106 part 101	Yes		
Dimensions			
Clamping range (rating- / min. / max.)	mm ²	Screw connection	Tension clamp connection
		2.5 / 0.5 / 4	1.5 / 0.5 / 2.5
Length x width x height	mm	93 / 6.1 / 92	94 / 6.1 / 91
Note	Cross-connectors and markers - refer to MICROSERIES accessories		

Ordering data	24 V DC 1CO Au	120 V UC 1CO Au	230 V AC 1CO Au	
Input				
Rated voltage	24 V DC ±20 %	120 V UC + 10 %/ -15 %	230 V AC ±10%	
Rated current AC		3.5mA ±15%	7.6mA	
Rated current DC	6.6 mA	3.5mA ±15%		
Power rating	160 mW	0.42 VA ±15%	1.75VA	
AC Response/dropout Volt		71 V/ 22 V	103V/49V	
DC Response/dropout Volt	15.4V/6.5V	71 V/ 22 V		
AC pickup/dropout current		1.8 mA/0.5 mA	5mA/2.5mA	
DC pickup/dropout current	4mA/1.2mA	1.8mA/0.5mA		
Ordering data Complete module				
Screw connection Type	MRS 24Vdc 1CO 5uAu	MRS 120Vuc 1CO 5uAu	MRS 230Vac 1CO 5uAu	
Order No.	8596060000	8652030000	8596050000	
Tension clamp connection Type	MRZ 24Vdc 1CO 5uAu	MRZ 120Vuc 1CO 5uAu	MRZ 230Vac 1CO 5uAu	
Order No.	8596080000	8652040000	8596070000	
Ordering data Spare relay, pluggable				
Type	RSS112024 24Vdc-Rel1U	RSS112060 60Vdc-Rel1U	RSS112024 24Vdc-Rel1U	
Order No.	4061590000	4061600000	4061590000	
Note	Safely switches loads of: 1...60 V AC/DC, 1...300 mA. The gold layer may be destroyed by switching greater voltages.	Safely switches loads of: 100 mV...60 V AC/DC, 1 mA...300 mA. The gold layer may be destroyed by switching greater voltages.	Safely switches loads of: 1...60 V AC/DC, 1...300 mA. The gold layer may be destroyed by switching greater voltages.	

RSS Relays
1 change-over contact DC coil

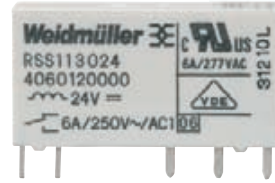

C

Contact life expectancy,
material AgSnO₂

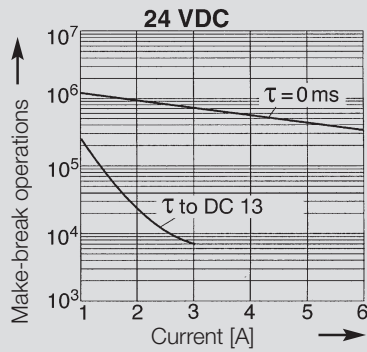
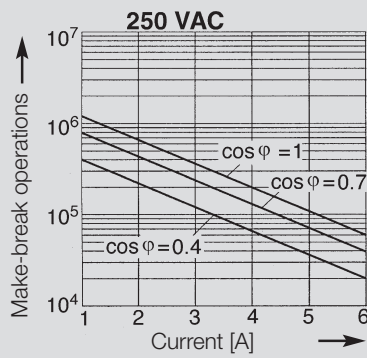

Dimensions

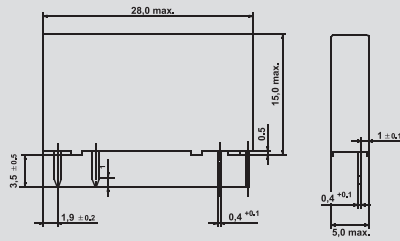

Technical data

Number of contacts and type	1 change-over contact
Contact form	single
Switching current	6 A
Switching voltage / max. switching voltage	250 V AC / 400 V AC
Switching capacity	1500 VA
Contact material / recommended min. load	AgSnO ₂ 12 V, 10 mA AgSnO ₂ 5μ Au 1 V, 1 mA ¹⁾
Typical bounce time, NOC	1 ms
Typical bounce time, NCC	5 ms
Other data	
UL 94 flammability rating	V-0
Ambient temperature	-40 ... +85 °C
Max. switching frequency at nom. load / without load	6/1200 make-break operations per minute
Pick-up / drop-out time	5 / 2.5 ms
Bounce time, NOC / NCC	1.5 / 5 ms
Ingress protection class housing	IP 67

¹⁾ Recommended switching capacity: μW up to 0.25 W (depends on load characteristics), at 2.5 W the silver coating remains effective for about 20 000 make-break operations.

Ordering data

	Type	Qty	Order No.
Coil voltage 5 V, 1 change-over contact	RSS 113005	20	4061580000
Coil voltage 12 V, 1 change-over contact	RSS 113012	20	4061610000
Coil voltage 24 V, 1 change-over contact	RSS 113024	20	4060120000
Coil voltage 48 V, 1 change-over contact	RSS 113048	20	4061620000
Coil voltage 60 V, 1 change-over contact	RSS 113060	20	4061630000
Coil voltage 24 V, 1 change-over contact, 5μ Au ¹⁾	RSS 112024	20	4061590000
Coil voltage 60 V, 1 change-over contact, 5μ Au ¹⁾	RSS 112060	20	4061600000

Type code for RSS relays

Type code	RSS				
Type	RIDER Signal Slim				
Model	1 Printing, vertical, washable				
Type of contact	1 Changeover contact				
Contact material	2 AgSnO ₂ htv 3 AgSnO ₂				
Coil	005	5 V DC			
	012	12 V DC			
	024	24 V DC			
	048	48 V DC			
	060	60 V DC			

Accessories

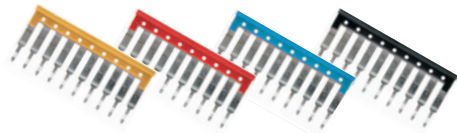

Plug-in cross-connection

Type	No. of poles	Qty	Order No.
yellow			
ZQV 4N / 2 GE	2	60	1758250000
ZQV 4N / 3 GE	3	60	1762630000
ZQV 4N / 4 GE	4	60	1762620000
ZQV 4N / 10 GE	10	20	1758260000
ZQV 4N / 20 GE	20	20	1909020000
red			
ZQV 4N / 2 RT	2	60	1793950000
ZQV 4N / 3 RT	3	60	1793980000
ZQV 4N / 4 RT	4	60	1794010000
ZQV 4N / 10 RT	10	20	1794040000
ZQV 4N / 20 RT	20	20	1909150000
blue			
ZQV 4N / 2 BL	2	60	1793960000
ZQV 4N / 3 BL	3	60	1793990000
ZQV 4N / 4 BL	4	60	1794020000
ZQV 4N / 10 BL	10	20	1794050000
ZQV 4N / 20 BL	20	20	1909100000
black			
ZQV 4N / 2 SW	2	60	1793970000
ZQV 4N / 3 SW	3	60	1794000000
ZQV 4N / 4 SW	4	60	1794030000
ZQV 4N / 10 SW	10	20	1794060000
ZQV 4N / 20 SW	20	20	1909120000

Other accessories

Type	Qty	Order No.	
Base only			
MXZ 24VDC 1CO BASIS	10	8826000000	
MXS 24VDC 1CO BASIS	10	8826010000	
MXZ 120VUC 1CO BASIS	10	8826020000	
MXS 120VUC 1CO BASIS	10	8826030000	
MXZ 230VAC 1CO BASIS	10	8826040000	
MXS 230VAC 1CO BASIS	10	8826050000	
Markers			
WS 12/6	12 x 6 mm	600	1609900000
Labels, Lasermark			
LM MT 300 15/6 ge	484 labels/sheet	10	1686360000
Screwdriver			
SD 0.6 x 3.5 x 100		10	9008330000

General data – MICROSERIES

Technical data

Conductor	Tension spring connection	Screw connection
Solid H07V-U	mm ² 0.5 ... 2.5	0.5 ... 4.0
Stranded H07V-K	mm ² 0.5 ... 2.5	0.5 ... 2.5
*F with wire end ferrules to DIN 46228-1	mm ² 0.5 ... 1.5	0.5 ... 1.5
*F with wire end ferrules with plastic collar	mm ² 0.5 ... 1.5	0.5 ... 1.5
Max. clamping range	mm ² 0.13 ... 2.5	0.13 ... 4.0
Plug gauge to IEC 60947-1	size A 2	A 3
General technical data		
Nominal torque	-	0.6
Continuous current for 2-pole cross-connection	A 10	10
Continuous current for multi-pole cross-connection	A 10	10
Stripping length	mm 10	7
Ingress protection class	IP 20	IP 20
Housing material	Wemid	Wemid
UL 94 flammability rating	V-0	V-0
Nominal current	A 6	6
Nominal voltage	V 250	250

C

Dimensions

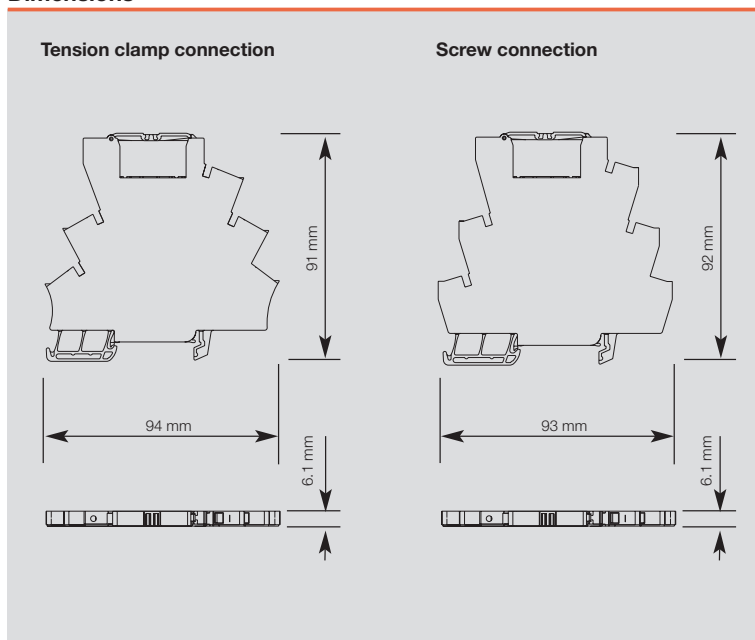

MICROinterface Digital

Link field and control with a system instead of masses of wires.

MICROinterface Digital is the answer to connecting eight MICROSERIES couplers to a PLC I/O module via pre-assembled lines. It results in simple, error-free connections between field and control.

C

First, set up a block of eight couplers using Weidmüller's well-known relays or optos from the MICROSERIES range (available with screw or tension clamp connections). Plug the interface module into the corresponding cross-connection openings using a ribbon cable or SUB-D connection. Using the pre-assembled cables available in various lengths, simply connect to the main PLC.

Features

- No tools required for installation
- Compatible with MICROSERIES screw and tension clamp connections
- Electrical isolation and signal adaptation with relays or optos as required

MICROinterface module for ribbon cable connection



MICROinterface module for SUB-D connection



MICROinterface digital

MI8DI-S/Z

Input module

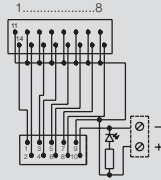

MI8DO-S/Z

Output module

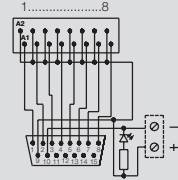

Technical data

Connection data

Type
Type of terminal / Connection system

Rated data

Operating voltage, max.
Current-carrying capacity
Total current feed, max.
Impulse withstand voltage (1.2/50 µs)
Rated insulation voltage
Storage temperature
Ambient temperature (operational)

Insulation coordination (EN 50 178)

Surge category
Pollution severity
Clearances/Creepage distances to EN

Clamping range (rating- / min. / max.) mm²
Length x width x height mm

Note

Ordering data

Connection system, pre-assembled cable
Ribbon cable connector, 10-pole
SUB-D plug, 15-pole
Ribbon cable connector, 10-pole
SUB-D plug, 15-pole

Note

Accessories

Note

Input module
MICROSERIES;Screw or tension clamp connection;Available for ribbon cable or Sub-D connection

30 V AC/DC
0.5 A per channel
2 A
330 V
32 V
-20 °C...+85 °C
0 °C...+55 °C

1
2
0.1 mm

2.5 / 0.5 / 2.5
48 x 59 x 53

Wiring diagram for ribbon cable

Type	Qty	Order No.
MI8DI-S F10 S	1	8773510000
MI8DI-S SUB D15S	1	8773460000
MI8DI-Z F10 S	1	8773530000
MI8DI-Z SUB D15S	1	8773490000

MI8DI-S = Screw connection
MI8DI-Z = Tension clamp connection

Output module
MICROSERIES;Screw or tension clamp connection;Available for ribbon cable or Sub-D connection

30 V AC/DC
0.5 A per channel
2 A
330 V
32 V
-20 °C...+85 °C
0 °C...+55 °C

1
2
0.1 mm

2.5 / 0.5 / 2.5
48 x 59 x 53

Wiring diagram for SUB-D

Type	Qty	Order No.
MI8DO-S F10 S	1	8773600000
MI8DO-S SUB D15S	1	8773550000
MI8DO-Z F10 S	1	8773620000
MI8DO-Z SUB D15S	1	8773570000

MI8DI-S = Screw connection
MI8DI-Z = Tension clamp connection

Relays - PLUGSERIES

1 change-over contact AC/DC coil

- Modular system comprising
- relay socket for rail mounting
 - LED indicator unit
 - Retaining clip
 - plug-in relay

cross-section of coil connections and relay changeover contacts by means of plug-in cross-connection ZQV 2.5N



C

DC version

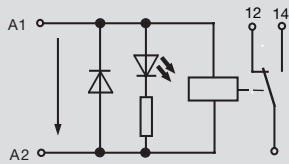

AC version

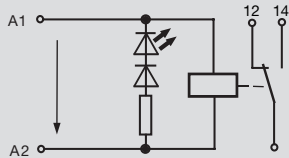

Output

max. switching voltage AC1/Continuous current	250 V/16 A
min. switching power	10 V / 100 mA
Response time / Drop-out time	5.8ms/6.9ms
Contact base material	AgNi 90/10
Mechanical endurance	30*10 ⁶ switching cycles
max. switching frequency at rated load	0.1 Hz

Rated data

Status indicator/Free wheel diode	LED green/Yes
Reverse pol. prot	No
Ambient temperature (operational)	-40 °C...+50 °C
Storage temperature	-40 °C...+ 50 °C
Humidity	40°C/93% RH, no condensation
Approvals	CE;cURus,CSA;

Insulation coordination (EN 50178)

Standards	EN 50178
Rated voltage	250 V
Impulse withstand voltage	6 kV
Clearance and creepage distances for control/load side	> 8 mm
Surge category	III
Pollution severity	2
Protective separation to VDE 0106 part 101	Yes

Dimensions

	Screw connection	Tension clamp connection
Clamping range (rating- / min. / max.)	mm ² 2.5 / 0.5 / 2.5	2.5 / 0.5 / 2.5
Length x width x height	mm 92 / 15.3 / 95	92 / 15.3 / 87

Note

Cross-connectors and markers - refer to PLUGSERIES accessories

Applications

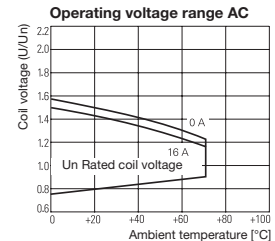
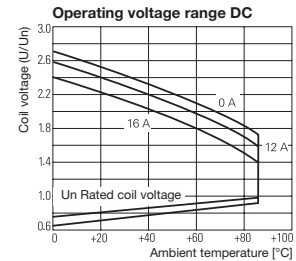
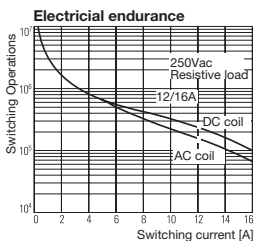
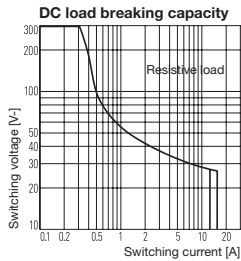

1 change-over contact AC/DC coil

Ordering data		12 V DC 1CO	24 V DC 1CO	115 V DC 1CO	24 V AC 1CO
Input					
Rated voltage		12 V DC $\pm 20\%$	24 V DC $\pm 10\%$	115 V DC $\pm 10\%$	24 V AC $\pm 10\%$
Rated current AC					32 mA
Rated current DC		33 mA	16 mA	3.5 mA	
Power rating		400 mW	400 mW	400 mW	0.75 VA
AC Response/dropout Volt					17V/3.6V
DC Response/dropout Volt		8.4V/1.2V	16.8 V / 2.4 V	76 V / 11 V	
Ordering data Relay with socket					
Screw connection	Type	PRS 12Vdc LD 1CO	PRS 24Vdc LD 1CO	PRS 115Vdc LD 1CO	PRS 24Vac LD 1CO
	Order No.	8536471001	8530621001	8536510000	8536530000
Tension spring connection	Type	PRZ 12Vdc LD 1CO	PRZ 24Vdc LD 1CO	PRZ 115Vdc LD 1CO	PRZ 24Vac LD 1CO
	Order No.	8536571001	8530691001	8536610000	8536651001
Ordering data Spare relay (pluggable)					
	Type	RCL314012	RCL314024	RCL314110	RCL314524
	Order No.	8693240000	8693260000	8821910000	8693500000
Note					
Ordering data		120 V AC 1CO	230 V AC 1CO		
Input					
Rated voltage		120 V AC $\pm 10\%$	230 V AC $\pm 10\%$		
Rated current AC		6.6 mA	3.2 mA		
Rated current DC					
Power rating		0.75 VA	0.75 VA		
AC Response/dropout Volt		86.3 V / 17.3 V	171 V / 34 V		
DC Response/dropout Volt					
Ordering data Relay with socket					
Screw connection	Type	PRS 120Vac LD 1CO	PRS 230Vac LD 1CO		
	Order No.	8530641001	8530671001		
Tension spring connection	Type	PRZ 120Vac LD 1CO	PRZ 230Vac LD 1CO		
	Order No.	8530710000	8530731001		
Ordering data Spare relay (pluggable)					
	Type	RCL314615	RCL314730		
	Order No.	8693890000	8693320000		
Note					

C

Relays - PLUGSERIES

2 change-over contacts AC/DC coil

- Modular system comprising
- relay socket for rail mounting
 - LED indicator unit
 - Retaining clip
 - plug-in relay

cross-section of coil connections and relay changeover contacts by means of plug-in cross-connection ZQV 2.5N



C

DC version

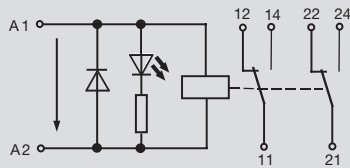

AC version

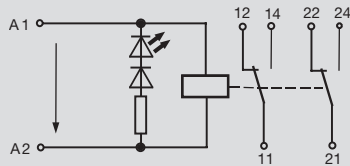

Output

max. switching voltage AC1/Continuous current	250 V/2 x 8 A
min. switching power	10 V / 100 mA
Response time / Drop-out time	9ms/45ms
Contact base material	AgNi 90/10
Mechanical endurance	5*10 ⁶ switching cycles
max. switching frequency at rated load	0.1 Hz

Rated data

Status indicator/Free wheel diode	LED green/Yes
Reverse pol. prot	No
Ambient temperature (operational)	-40 °C...+50 °C
Storage temperature	-40 °C...+ 50 °C
Humidity	40°C/93% RH, no condensation
Approvals	CE; cURus; CSA;

Insulation coordination (EN 50178)

Standards	EN 50178
Rated voltage	250 V
Impulse withstand voltage	6 kV
Clearance and creepage distances for control/load side	> 8 mm
Surge category	III
Pollution severity	2
Protective separation to VDE 0106 part 101	Yes

Dimensions

	Screw connection	Tension clamp connection
Clamping range (rating- / min. / max.)	mm ² 2.5 / 0.5 / 2.5	2.5 / 0.5 / 2.5
Length x width x height	mm 92 / 15.3 / 95	92 / 15.3 / 87

Note

Cross-connectors and markers - refer to PLUGSERIES accessories

Applications

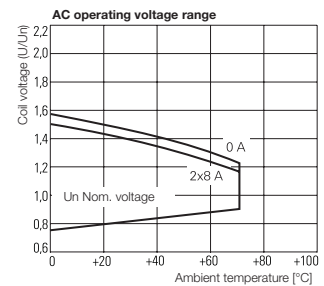
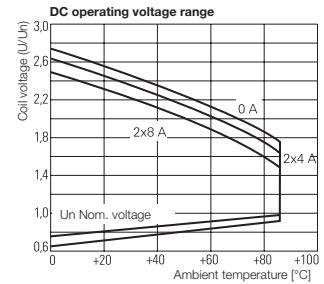
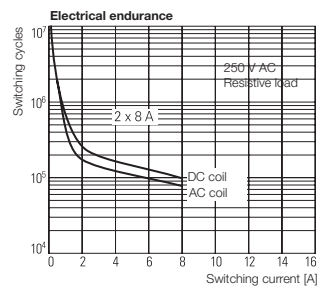
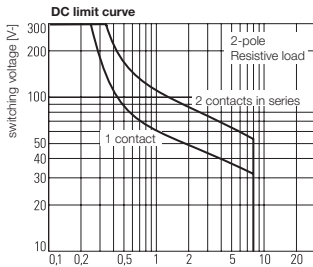

2 change-over contacts
AC/DC coil

C

Ordering data	12 V DC 2CO	24 V DC 2CO	115 V DC 2CO	24 V AC 2CO
Input				
Rated voltage	12 V DC ±20%	24 V DC ±10%	115 V DC ±10 %	24 V AC ±10 %
Rated current AC				32 mA
Rated current DC	33 mA	16 mA	3.5 mA	
Power rating	400 mW	400 mW	400 mW	0.75 VA
AC Response/dropout Volt				17 V / 3.6 V
DC Response/dropout Volt	8.4 V / 1.2 V	16.8 V / 2.4 V	76 V / 11 V	
Ordering data				
Relay with socket				
Screw connection Type	PRS 12Vdc LD 2CO	PRS 24Vdc LD 2CO	PRS 115Vdc LD 2CO	PRS 24Vac LD 2CO
Order No.	8536501001	8530631001	8536520000	8536560000
Tension spring connection Type	PRZ 12Vdc LD 2CO	PRZ 24Vdc LD 2CO	PRZ 115Vdc LD 2CO	PRZ 24Vac LD 2CO
Order No.	8536591001	8530701001	8536630000	8536681001
Ordering data				
Spare relay (pluggable)				
Type	RCL 424012 12Vdc-Rel2U	RCL 424024 24Vdc-Rel2U	RCL 424110 110Vdc-Rel2U	RCL 424524 24Vac-Rel2U
Order No.	4058560000	4058570000	4058590000	4058600000
Note				

Ordering data	120 V AC 2CO	230 V AC 2CO		
Input				
Rated voltage	120 V AC ±10 %	230 V AC ±10%		
Rated current AC	6.6 mA	3.2 mA		
Rated current DC				
Power rating	0.75 VA	0.75 VA		
AC Response/dropout Volt	86.3 V/ 17.3 V	172.5 V/ 34.5 V		
DC Response/dropout Volt				
Ordering data				
Relay with socket				
Screw connection Type	PRS 120Vac LD 2CO	PRS 230Vac LD 2CO		
Order No.	8530661001	8530681001		
Tension spring connection Type	PRZ 120Vac LD 2CO	PRZ 230Vac LD 2CO		
Order No.	8530720000	8530741001		
Ordering data				
Spare relay (pluggable)				
Type	RCL 424615 115Vac-Rel2U	RCL 424730 230Vac-Rel2U		
Order No.	4058610000	4058630000		
Note				

Relays - PLUGSERIES

2 change-over contacts with gold-plated contacts AC/DC coil

- Modular system comprising
- relay socket for rail mounting
 - LED indicator unit
 - Retaining clip
 - plug-in relay

cross-section of coil connections and relay changeover contacts by means of plug-in cross-connection ZQV 2.5N

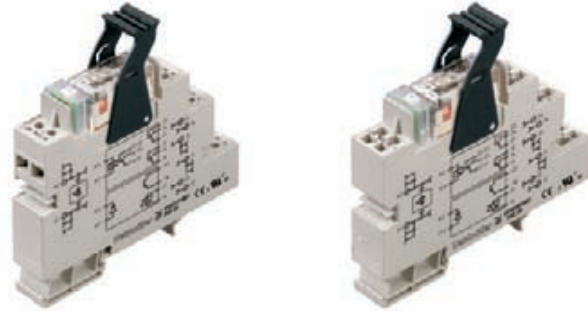

C

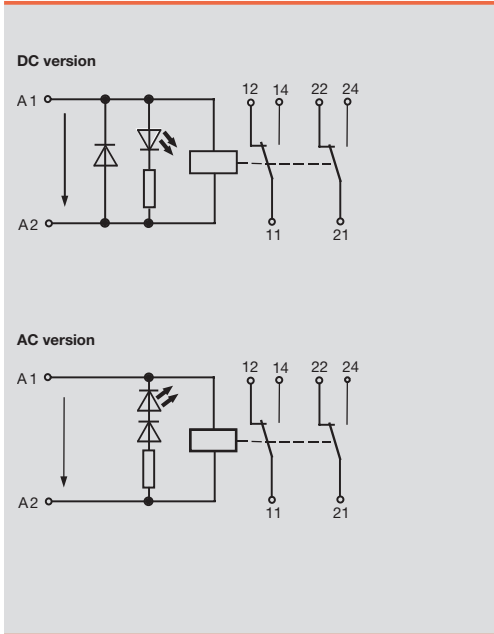

Output		
max. switching voltage AC1/Continuous current	250 V/2 x 8 A	
min. switching power	1 V / 1 mA	
Response time / Drop-out time	9ms/45ms	
Contact base material	AgNi 5µm Au	
Mechanical endurance	5*10 ⁶ switching cycles	
max. switching frequency at rated load	0.1 Hz	
Rated data		
Status indicator/Free wheel diode	LED green/no	
Reverse pol. prot	No	
Ambient temperature (operational)	-40 °C...+50 °C	
Storage temperature	-40 °C...+ 50 °C	
Humidity	40°C/93% RH, no condensation	
Approvals	CE;cURus;CSA;	
Insulation coordination (EN 50178)		
Standards	EN 50178	
Rated voltage	250 V	
Impulse withstand voltage	6 kV	
Clearance and creepage distances for control/load side	> 8 mm	
Surge category	III	
Pollution severity	2	
Protective separation to VDE 0106 part 101	Yes	
Dimensions		
Clamping range (rating- / min. / max.)	mm ²	Screw connection
		2.5 / 0.5 / 2.5
Length x width x height	mm	Tension clamp connection
		2.5 / 0.5 / 2.5
		92 / 15.3 / 95
		92 / 15.3 / 87
Note		
Cross-connectors and markers - refer to PLUGSERIES accessories		

Ordering data

Input	24 V DC 2CO Au	120 V AC 2CO Au	230 V AC 2CO AU	
Rated voltage	24 V DC ±10%	120 V AC ±10 %	230 V AC ±10%	
Rated current AC		6.6 mA	3.2 mA	
Rated current DC	16 mA			
Power rating	400 mW	0.75 VA	0.75 VA	
AC Response/dropout Volt		86,3 V/ 17,3 V	172.5 V/ 34.5 V	
DC Response/dropout Volt	16.8 V / 2.4 V			

Ordering data Complete module

Screw connection	Type	PRS 24VDC LD 2COAU	PRS 120VAC LD 2CO AU	PRS 230VAC LD 2CO AU	
Order No.		8561760000	8595960000	8595990000	
Tension clamp connection	Type	PRZ 24Vdc LD 2CO AU	PRZ 120VAC LD 2COAU	PRZ 230VAC LD 2COAU	
Order No.		8552440000	8575940000	8575950000	

Ordering data Spare relay, pluggable

Type	RCL 425024 24Vdc-Rel2U	RCL 425615 115Vac-Rel2U	RCL 425730 230Vac-Rel2U	
Order No.	4058580000	4058620000	4058640000	

Note	Can safely switch a load of: 1...60 V AC/DC, 1...300 mA. If higher loads are switched this can damage the gold plating.	Can safely switch a load of: 1...60 V AC/DC, 1...300 mA. If higher loads are switched this can damage the gold plating.	Can safely switch a load of: 1...60 V AC/DC, 1...300 mA. If higher loads are switched this can damage the gold plating.	

Accessories

PLUGSERIES

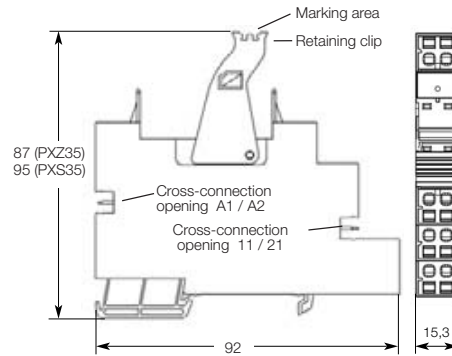

Technical data

Base without relay	
Nominal current	16 A
Nominal voltage	250 V
Dielectric strength coil/contact	> 4 kV
Ingress protection class	IP 20
Nominal cross-section	2.5 mm ²
Stripping length	8 mm
	screw connection
	tension clamp connection
Ambient temperature	-40 °C ... +60 °C
UL 94 flammability rating	V-0

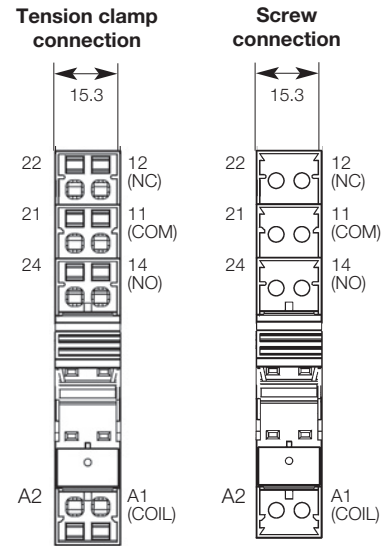

Ordering data

Base for mounting on TS 35 DIN Rail		Type	Qty	Order No.
Screw connection		PXS35	10	8533771001
Tension clamp connection		PXZ35	10	8536691001
Retaining clip		PRC	100	8536700000
LED indicator with free wheel diode		PLED 24 V DC	20	8536710000
6 ... 24 V DC		PLED 24 V DC rot	20	8611010000
red LED, 6 ... 24 V DC		PLED 48 V DC	20	8536720000
48 ... 60 V DC		PLED 115 V DC	20	8536730000
115 V DC		PLED 24 V AC	20	8536750000
12 ... 24 V AC		PLED 120 V AC	20	8536760000
115 V AC		PLED 230 V AC	20	8536780000
230 V AC		PLRC 200 nF/200Ω	20	8566530000
RC combination 120 ... 230 V AC/DC				
Plug-in cross-connections		ZQV 2.5N/4-2SW	60	1784270000
2-pole	black	ZQV 2.5N/4-2RT	60	1784280000
	red	ZQV 2.5N/4-2BL	60	1784290000
	blue			
Markers		WS 10/5	200	1060860000
	10 x 5 mm	WS 15/5	96	1609880000
	15 x 5 mm			

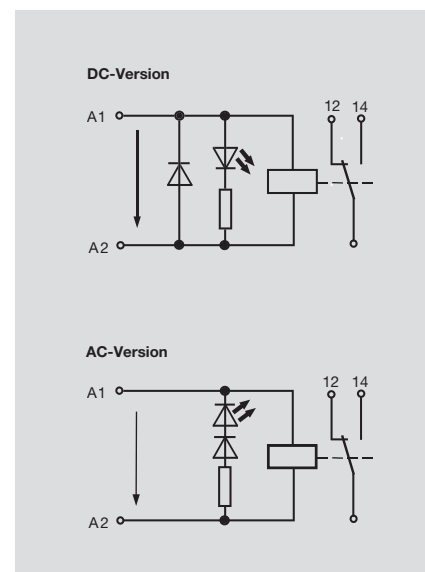

Relays - RIDERSERIES

**RCL relay
1 CO contact AC/DC coil**

- 3000 or 4000 VA switching capacity
- Low height of 15.7 mm
- Hard gold-plated contacts available
- For boiler controls, timer relays, garage door controls, Interface modules

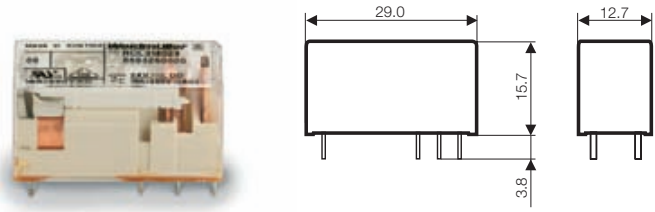

C

PCB layout / terminal assignment

View on solder pins, dimensions in mm

1 C/O changeover contacts

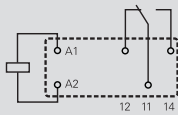

12 A, Pinning 3.5 mm

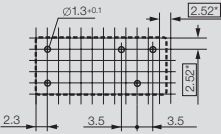

1 C/O changeover contacts

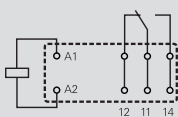

16 A, Pinning 5 mm

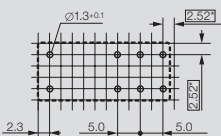

Output

max. switching voltage AC1	250 V
Continuous current	12 A for 3.5 mm / 16 A for 5 mm pinning
Contact base material	AgNi 90/10 or AgNi 5µm Au
Mechanical endurance	AC coil 10*10 ⁶ / DC coil 30*10 ⁶ switching operations
Response time / Drop-out time	

Rated data

Status indicator/Free wheel diode	no/no
Ambient temperature (operational)	-40 °C...+70 °C
UL 94 flammability rating	V-0
Approvals	cURus; VDE;

Insulation coordination (IEC 60664)

Rated voltage	250 V
Clearance and creepage distances for control/load side	10 mm
Surge category	III
Pollution severity	3
Protective separation to VDE 0106 part 101	Yes

Dimensions

Length x width x height	mm	29 / 12.7 / 15.7
-------------------------	----	------------------

Note

Applications

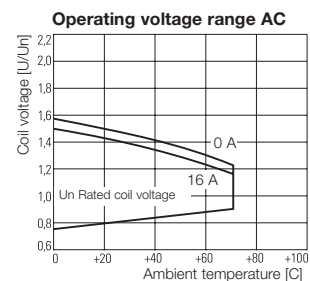
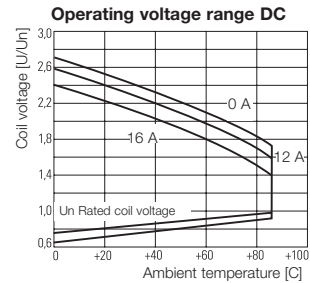
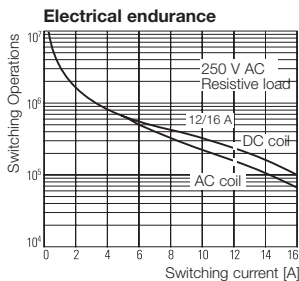
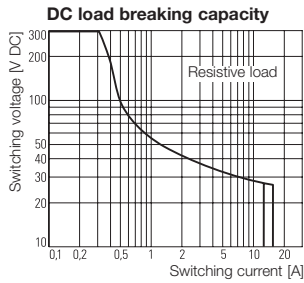

RCL relay
1 CO contact AC/DC coil

Type code	RCL				
Type	RIDER Control Low				
Type of construction	1 12 A, Pitch 3,5 mm, flux proof 3 16 A, Pitch 5 mm, flux proof				
Type of contact	1 1 CO contacts 3 1 NO contacts				
Contact material	4 AgNi 90/10 5 AgNi 90/10 hgp				
DC coil	006 6 V DC 012 12 V DC 024 24 V DC 048 48 V DC 060 60 V DC 110 110 V DC				
AC coil	512 12 V AC 524 24 V AC 548 48 V AC 615 115 V AC 730 230 V AC				

Ordering data

Input	6 V DC 1CO	12 V DC 1CO	24 V DC 1CO	48 V DC 1CO
Rated voltage	6 V DC	12 V DC	24 V DC	48 V DC
DC Response/dropout Volt	4.2 V / 0.6 V	8.4 V / 1.2 V	16.8 V / 2.4 V	33.6 V / 4.8 V
Power rating	500 mW	500 mW	500 mW	500 mW
Rated current DC	66.7 mA	33.3 mA	16.7 mA	8.7 mA
Coil resistance	90 Ω ±10%	360 Ω ±10%	1440 Ω ±10%	5520 Ω ±10%

Ordering data Relay

12 A / 3.5 mm Type	RCL114006	RCL114012	RCL114024	RCL114048
AgNi 90/10 Order No.	8693400000	8693190000	8693180000	8693480000
16 A / 5 mm Type	RCL314006	RCL314012	RCL314024	RCL314048
AgNi 90/10 Order No.	8693800000	8693240000	8693260000	8693380000
16 A / 5 mm Type			RCL315024	
AgNi 5µm Au Order No.			8824830000	

Note

Ordering data

Input	24 V AC 1CO	48 V AC 1CO	115 V AC 1CO	230 V AC 1CO
Rated voltage	24 V AC	48 V AC	115 V AC	230 V AC
AC Response/dropout Volt	18.0 V / 3.6 V	64 V / 7.2 V	86.3 V / 17.3 V	172.5 V / 34.5 V
Power rating	0.75 VA	0.75 VA	0.75 VA	0.75 VA
Rated current AC	31.6 mA	15.6 mA	6.6 mA	3.2 mA
Coil resistance	1440 Ω ±10%	1420 Ω ±10%	8100 Ω ±15%	32500 Ω ±15%

Ordering data Relay

12 A / 3.5 mm Type	RCL114524	RCL114548	RCL114615	RCL114730
AgNi 90/10 Order No.	8693220000	8693510000	8693390000	8693230000
16 A / 5 mm Type	RCL314524	RCL314548	RCL314615	RCL314730
AgNi 90/10 Order No.	8693500000	8693880000	8693890000	8693320000
16 A / 5 mm Type	RCL315524		RCL315615	RCL315730
AgNi 5µm Au Order No.	8824870000		8824880000	8824890000

Note

Relays - RIDERSERIES

RCL relay
2 CO contact AC/DC coil

- 2000 VA switching capacity
- Low height of 15.7 mm
- Hard gold-plated contacts available
- For domestic appliances, heating controllers, emergency lighting systems, modems

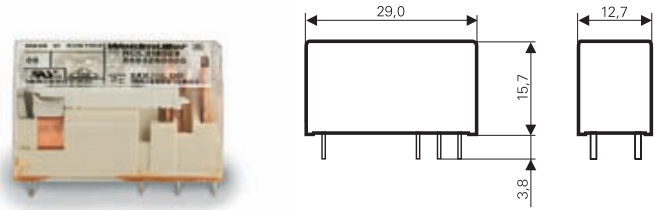

C

Circuit diagram

View of connections
Dimensions in mm

2 C/O changeover contacts

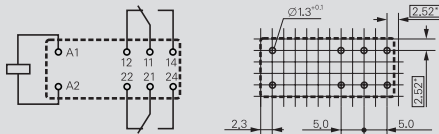

Output

max. switching voltage AC1	250 V
Continuous current	8 A / 1 contact
Contact base material	AgNi 90/10 or AgNi 5µm Au
Mechanical endurance	AC coil 5*10 ⁶ / DC coil 30*10 ⁶ switching operations
Response time / Drop-out time	7ms / 2ms

Rated data

Status indicator/Free wheel diode	no/no
Ambient temperature (operational)	-40 °C...+70 °C
UL 94 flammability rating	V-0
Approvals	cURus; VDE;

Insulation coordination (IEC 60664)

Rated voltage	250 V
Clearance and creepage distances for control/load side	10 mm
Surge category	III
Pollution severity	3
Protective separation to VDE 0106 part 101	Yes

Dimensions

Length x width x height mm 29 / 12.7 / 15.7

Note

Applications

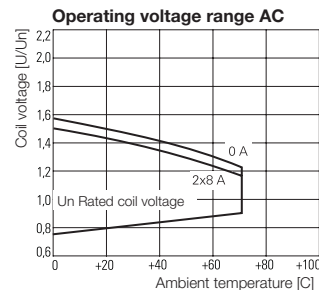
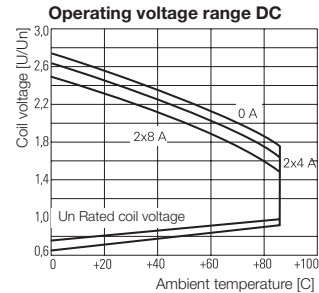
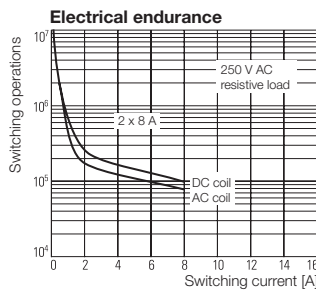
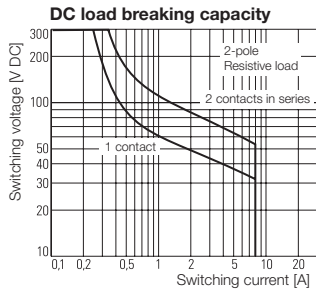

**RCL relay
2 CO contact AC/DC coil**

Type code	RCL				
Type	RIDER Control Low				
Type of construction	4 8 A, pitch 5 mm, flux proof				
Type of contact	2 2 CO contacts 4 2 NO contacts				
Contact material	4 AgNi 90/10 5 AgNi 90/10 hgp				
DC coil	006	6 V DC			
	012	12 V DC			
	024	24 V DC			
	048	48 V DC			
	060	60 V DC			
	110	110 V DC			
AC coil	512	12 V AC			
	524	24 V AC			
	548	48 V AC			
	615	115 V AC			
	730	230 V AC			

Ordering data

Input	12 V DC 2CO	24 V DC 2CO	48 V DC 2CO	110 V DC 2CO
Rated voltage	12 V DC	24 V DC	48 V DC	110 V DC
DC Response/dropout Volt	8.4 V / 1.2 V	16.8 V / 2.4 V	33.6 V / 4.8 V	77 V / 11 V
Power rating	500 mW	500 mW	500 mW	500 mW
Rated current DC	33.3 mA	16.7 mA	8.7 mA	4.1 mA
Coil resistance	360 Ω ±10%	1440 Ω ±10%	5520 Ω ±10%	26600 Ω ±12%

**Ordering data
Relay**

8 A / 5 mm	Type	12 V DC 2CO	24 V DC 2CO	48 V DC 2CO	110 V DC 2CO
AgNi 90/10	Order No.	RCL 424012 12Vdc-Rel2U 4058560000	RCL 424024 24Vdc-Rel2U 4058570000	RCL424048 4058750000	RCL 424110 110Vdc-Rel2U 4058590000
	Type				
	Order No.				
8 A / 5 mm	Type	RCL 425012	RCL 425024 24Vdc-Rel2U	RCL 425048	RCL425110
AgNi 5 µm Au	Order No.	on request	4058580000	on request	8828370000

Note

Ordering data

Input	24 V AC 2CO	48 V AC 2CO	115 V AC 2CO	230 V AC 2CO
Rated voltage	24 V AC	48 V AC	115 V AC	230 V AC
AC Response/dropout Volt	18 V / 3.6 V	64 V / 7.2 V	86.3 V / 17.3 V	172.5 V / 34.5 V
Power rating	0.75 VA	0.75 VA	0.75 VA	0.75 VA
Rated current AC	31.6 mA	15.6 mA	6.6 mA	3.2 mA
Coil resistance	350 Ω ±10%	1420 Ω ±10%	8100 Ω ±15%	32500 Ω ±15%

**Ordering data
Relay**

8 A / 5 mm	Type	24 V AC 2CO	48 V AC 2CO	115 V AC 2CO	230 V AC 2CO
AgNi 90/10	Order No.	RCL 424524 24Vac-Rel2U 4058600000	RCL424548 8693340000	RCL 424615 115Vac-Rel2U 4058610000	RCL 424730 230Vac-Rel2U 4058630000
	Type				
	Order No.				
8 A / 5 mm	Type	RCL 425524	RCL 425548	RCL 425615 115Vac-Rel2U	RCL 425730 230Vac-Rel2U
AgNi 5 µm Au	Order No.	on request	on request	4058620000	4058640000

Note



Relays - RIDERSERIES

RCLS – Inrush Power

- 1 NO
- High making currents possible
- RCLS3L 120 A for max. 20 ms
- RCLS3T 165 A for max. 20 ms / 800 A for 200 µs
- New contact principle

Switching contact for AgSnO2

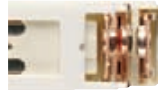

Switching contact for AgSnO2+W

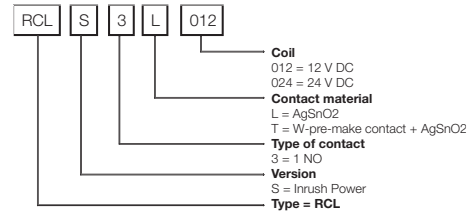

C

Circuit diagram

View of connections
Dimensions in mm

1 NO contact

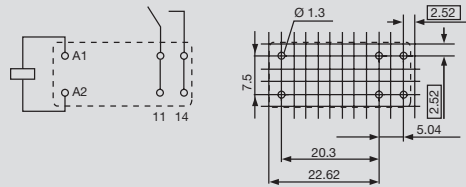

Output

Max. switching voltage AC	240 V
Rated current	16 A
Max. switching current	120 A @ 20 ms (RCLS3L) 165 A @ 20 ms / 800 A @ 200 µs (RCLS3T)
Contact base material	AgSnO2 (RCLS3L) / AgSnO2 + W (RCLS3T)
Mechanical endurance	10 x 10 ⁶ (RCLS3L) / 5 x 10 ⁶ (RCLS3T)
Response time / Release time	10 ms / 4 ms

Rated data

Ambient temp., fitted w/o distance	-25 °C ... +70 °C
Flammability rating UL 94	V-0
Approvals	cURus / VDE

Insulation coordinates (IEC 60664)

Rated voltage	250 V
Creepage and clearance path input – output	10 mm
Surge category	III
Pollution severity	2

Dimensions

Length x width x height	mm	29 / 12.7 / 15.7
-------------------------	----	------------------

Information

Order data

Input	12 V DC 1NO	24 V DC 1NO	12 V DC 1NO	24 V DC 1NO
Rated voltage	12 V DC	24 V DC	12 V DC	24 V DC
Rated current DC	33.3 mA	16.7 mA	33.3 mA	16.7 mA
Power rating	400 mW	400 mW	400 mW	400 mW
Oper./drop-out volt. DC-coil	8.4 V / 1.2 V	16.8 V / 2.4 V	8.4 V / 1.2 V	16.8 V / 2.4 V

Order data

Break contact element	Type	RCLS 3L012	RCLS 3L024	RCLS 3T012	RCLS 3T024
	Order No.	8866890000	8866900000	8866910000	8866920000

Information

Contact material AgSnO2	Contact material AgSnO2	Contact material AgSnO2 + W	Contact material AgSnO2 + W
-------------------------	-------------------------	-----------------------------	-----------------------------

Safe. Fast. RIDERSERIES.

The RIDERSERIES relays with industrial pinning and bases with Push In connectivity.

Profit from the unbeatable advantages offered by the RIDERSERIES relays:

- Safe: industrial pinning
- Useful: free-wheeling diode and LED indicator
- Practical: test lever for mechanical operation of the contacts
- Fast: base with Push In connection
- Time-saving: cross connections can be instantly plugged-in



Discover the advantages of our new RIDERSERIES for yourself.

Safe. Simple. RCI.

The new RCI power relays from Weidmüller have been developed for use in industrial applications. Thanks to their outstanding contact properties, the relays can handle power up to 16 A with 24 Vdc or 230 Vac. To split the signal, simply use two change-over contacts, in which case the contacts each switch loads of up to 8 A with 24 Vdc or 230 Vac. As a handy extra detail, the AC and DC inputs are different colours for easy identification.

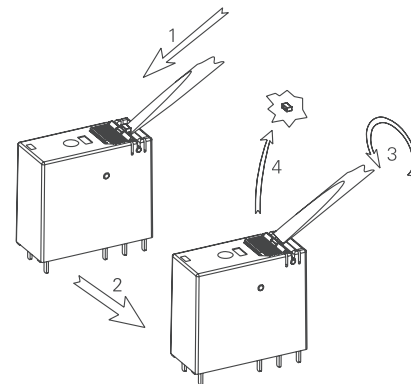

Reducing assembly time into the base: the integrated free-wheeling diode (DC) and the LED indicator.



Establishing reliable connections: strong industrial pins for safe and fast assembly.



Easy to use: test lever for mechanical operation of the contacts.



Simply release the catch and the test lever will click into place.

Fast. Straightforward. Push In.

RIDERSERIES relay bases are equipped with Push In connectivity. That means you need 75 % less time for wiring than for a relay base with a screw connection because solid and crimped conductors can simply be inserted without the need to open the clamping point. Other accessories include modules for input wiring, retaining clips and multcard markers.

It's never been so easy. Insert the conductor and you're done – a safe connection has been made! Each connection has two clamping points for conductors up to 1.5 mm².



Time-saving cross-connections: two-pin bridges for instantly pluggable electrical distribution in the input and output. You only need one clamping point for each Push In connection – the second one remains free for other connections!

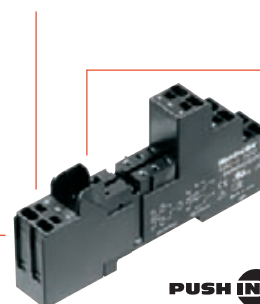

Extremely practical: a universal slot allows you to add modules to wire the relay coil, e.g. for varistors, resistances or RC combinations.



Relays - RIDERSERIES

RCI KIT with screw connection 1 changeover contact

- 4000 VA switching capacity
- Stable plug-in connections
- LED (AC red / DC green) integrated in relay
- Protective suppressor circuit for DC coil
- Optional test button with latching function and inspection window
- Identification of coils (AC red / DC blue)



C

DC version

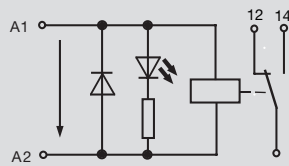

AC version

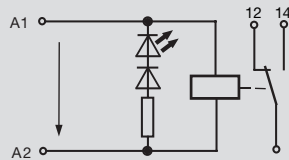

Output

max. switching voltage AC1	250 V
Continuous current	16 A
Contact base material	AgNi 90/10
Mechanical endurance	AC coil 5*10 ⁶ / DC coil 10*10 ⁶ switching operations
Response time / Drop-out time	7 ms / 3 ms

Rated data

Status indicator / Free wheel diode	yes / yes
Ambient temperature (operational)	-40 °C...+70 °C
UL 94 flammability rating	V-0
Approvals	CE, GL*

Insulation coordination (IEC 60664)

Rated voltage	250 V
Clearance and creepage distances for control/load side	8 mm
Surge category	III
Pollution severity	3
Protective separation to VDE 0106 part 101	Yes

Dimensions

Clamping range (rating- / min. / max.)	mm ²	2.5 / 0.5 / 2.5
Length x width x height	mm	70 / 15.5 / 77

Screw connection

Note *Only valid for RCI kits with test button

Ordering data

Input	24 V DC 1CO	24 V AC 1CO	115 V AC 1CO	230 V AC 1CO
Rated voltage	24 V DC	24 V AC	115 V AC	230 V AC
Rated current AC		31.6 mA	6.6 mA	3.2 mA
Rated current DC	16.7 mA			
Power rating	400 mW	0.75 VA	0.75 VA	0.75 VA
AC Response/dropout Volt		18.0 V / 3.6 V	86.3 V / 17.3 V	172.5 V / 34.5 V
DC Response/dropout Volt	16.8 V / 2.4 V			
Coil resistance	1440 Ω ±10%	350 Ω ±10%	8100 Ω ±15%	32500 Ω ±15%

Ordering data

Complete module

with test button	Type	RCIKIT 24VDC 1CO LD/PB	RCIKIT 24VAC 1CO LD/PB	RCIKIT 115VAC 1CO LD/PB	RCIKIT 230VAC 1CO LD/PB
	Order No.	8881580000	8881590000	8897060000	8881600000
without test button	Type	RCIKIT 24VDC 1CO LED	RCIKIT 24VAC 1CO LED	RCIKIT 115VAC 1CO LD	RCIKIT 230VAC 1CO LED
	Order No.	8871000000	8871010000	8897090000	8871020000

Ordering data

Spare relay, pluggable

	w. test button		w.o. test button		w. test button		w.o. test button	
Type	RCI314AC4	RCI374AC4	RCI374R24	RCI314R24	RCI374S15	RCI314S15	RCI314T30	RCI374T30
Order No.	8870100000	8870250000	8870280000	8870130000	8870290000	8870140000	8870150000	8870300000

Note

**RCI-KITP with push-in connection
1 changeover contact**

- 4000 VA switching capacity
- Stable plug-in connections
- LED (AC red / DC green) integrated in relay
- Protective suppressor circuit for DC coil
- Optional test button with latching function and inspection window
- Identification of coils (AC red / DC blue)

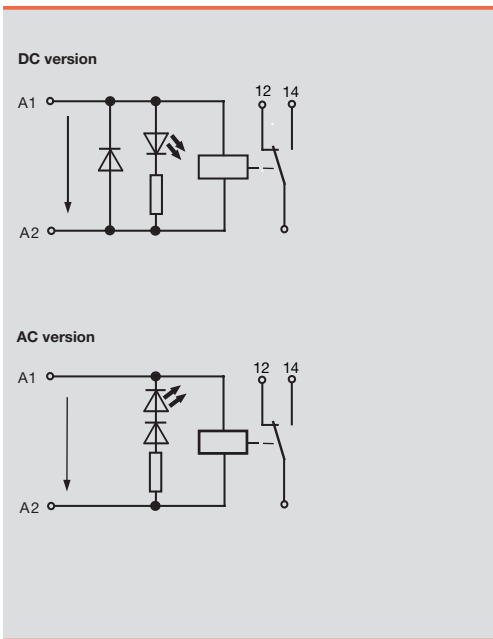

Output	
max. switching voltage AC1	250 V
Continuous current	16 A
Contact base material	AgNi 90/10
Mechanical endurance	AC coil 5*10 ⁶ / DC coil 10*10 ⁶ switching operations
Response time / Drop-out time	7 ms / 3 ms
Rated data	
Status indicator / Free wheel diode	yes / yes
Ambient temperature (operational)	-40 °C...+70 °C
UL 94 flammability rating	V-0
Approvals	CE, GL*
Insulation coordination (IEC 60664)	
Rated voltage	250 V
Clearance and creepage distances for control/load side	8 mm
Surge category	III
Pollution severity	3
Protective separation to VDE 0106 part 101	Yes
Dimensions	
Clamping range (rating- / min. / max.)	mm ² 1.5 / 0.5 / 1.5
Length x width x height	mm 70 / 15.5 / 98
Push-In	
Note	
*Only valid for RCI kits with test button	

Ordering data

Input	24 V DC 1C0	24 V AC 1C0	115 V AC 1C0	230 V AC 1C0
Rated voltage	24 V DC	24 V AC	115 V AC	230 V AC
Rated current AC		31.6 mA	6.6 mA	3.2 mA
Rated current DC	16.7 mA			
Power rating	400 mW	0.75 VA	0.75 VA	0.75 VA
AC Response/dropout Volt		18.0 V / 3.6 V	86.3 V / 17.3 V	172.5 V / 34.5 V
DC Response/dropout Volt	16.8 V / 2.4 V			
Coil resistance	1440 Ω ±10%	350 Ω ±10%	8100 Ω ±15%	32500 Ω ±15%

Ordering data Complete module

	Type	RCIKITP 24VDC 1C0 LD/PB	RCIKITP 24VAC 1C0 LD/PB	RCIKITP115VAC 1C0 LD/PB	RCIKITP230VAC 1C0 LD/PB
with test button	Order No.	8897190000	8897200000	8897210000	8897220000
without test button	Type	RCIKITP 24VDC 1C0 LD	RCIKITP 24VAC 1C0 LD	RCIKITP 115VAC 1C0 LD	RCIKITP 230VAC 1C0 LD
	Order No.	8897110000	8897120000	8897130000	8897140000

Ordering data Spare relay, pluggable

	Type	w. test button	w.o. test button	w. test button	w.o. test button	w. test button	w.o. test button
	Type	RCI314AC4	RCI374AC4	RCI374R24	RCI314R24	RCI374S15	RCI314S15
	Order No.	8870100000	8870250000	8870280000	8870130000	8870290000	8870140000
							RCI314T30 RCI374T30
	Order No.						8870150000 8870300000

Note

Relays - RIDERSERIES

RCI KIT with screw connection 2 changeover contacts

- 4000 VA switching capacity
- Stable plug-in connections
- LED (AC red / DC green) integrated in relay
- Protective suppressor circuit for DC coil
- Optional test button with latching function and inspection window
- Identification of coils (AC red / DC blue)



C

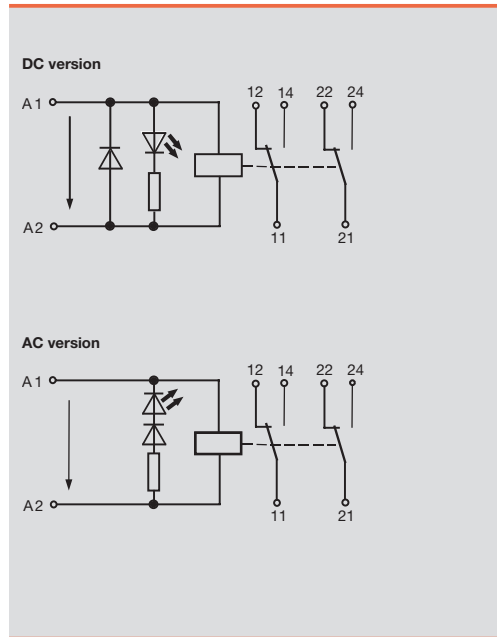

Output	
max. switching voltage AC1	250 V
Continuous current	8 A / 1 contact
Contact base material	AgNi 90/10
Mechanical endurance	AC coil 5*10 ⁶ / DC coil 10*10 ⁶ switching operations
Response time / Drop-out time	7 ms / 2 ms
Rated data	
Status indicator / Free wheel diode	yes / yes
Ambient temperature (operational)	-40 °C...+70 °C
UL 94 flammability rating	V-0
Approvals	CE, GL*
Insulation coordination (IEC 60664)	
Rated voltage	250 V
Clearance and creepage distances for control/load side	8 mm
Surge category	III
Pollution severity	3
Protective separation to VDE 0106 part 101	Yes
Dimensions	
Clamping range (rating- / min. / max.)	mm ² 2.5 / 0.5 / 2.5
Length x width x height	mm 70 / 15.5 / 77
Screw connection	
*Only valid for RCI kits with test button	

Ordering data	24 V DC 2CO	24 V AC 2CO	115 V AC 2CO	230 V AC 2CO
Input				
Rated voltage	24 V DC	24 V AC	115 V AC	230 V AC
Rated current AC		31.6 mA	6.6 mA	3.2 mA
Rated current DC	16.7 mA			
Power rating	400 mW	0.75 VA	0.75 VA	0.75 VA
AC Response/dropout Volt		18.0 V / 3.6 V	86.3 V / 17.3 V	172.5 V / 34.5 V
DC Response/dropout Volt	16.8 V / 2.4 V			
Coil resistance	1440 Ω ±10%	350 Ω ±10%	8100 Ω ±15%	32500 Ω ±15%
Ordering data Complete module				
with test button	Type RCIKIT 24VDC 2CO LD/PB	Type RCIKIT 24VAC 2CO LD/PB	Type RCIKIT 115VAC 2CO LD/PB	Type RCIKIT 230VAC 2CO LD/PB
	Order No. 8881610000	Order No. 8881620000	Order No. 8897080000	Order No. 8881630000
without test button	Type RCIKIT 24VDC 2CO LED	Type RCIKIT 24VAC 2CO LED	Type RCIKIT 115VAC 2CO LD	Type RCIKIT 230VAC 2CO LED
	Order No. 8871030000	Order No. 8871040000	Order No. 8897100000	Order No. 8871050000
Ordering data Spare relay, pluggable	w. test button	w.o. test button	w. test button	w.o. test button
Type	RCI424AC4	RCI484AC4	RCI424S15	RCI484S15
Order No.	8870180000	8870320000	8870220000	8870360000
Note				

**RCI-KITP with push-in connection
2 changeover contacts**

- 4000 VA switching capacity
- Stable plug-in connections
- LED (AC red / DC green) integrated in relay
- Protective suppressor circuit for DC coil
- Optional test button with latching function and inspection window
- Identification of coils (AC red / DC blue)

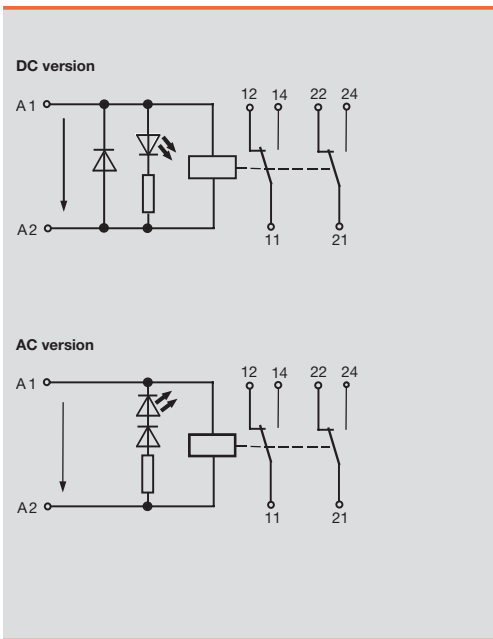

Output	
max. switching voltage AC1	250 V
Continuous current	8 A / 1 contact
Contact base material	AgNi 90/10
Mechanical endurance	AC coil 5*10 ⁶ / DC coil 10*10 ⁶ switching operations
Response time / Drop-out time	7 ms / 2 ms
Rated data	
Status indicator / Free wheel diode	yes / yes
Ambient temperature (operational)	-40 °C...+70 °C
UL 94 flammability rating	V-0
Approvals	CE, GL*
Insulation coordination (IEC 60664)	
Rated voltage	250 V
Clearance and creepage distances for control/load side	8 mm
Surge category	III
Pollution severity	3
Protective separation to VDE 0106 part 101	Yes
Dimensions	
Clamping range (rating- / min. / max.)	mm ² 1.5 / 0.5 / 1.5
Length x width x height	mm 70 / 15.5 / 98
Note	
*Only valid for RCI kits with test button	

Ordering data

Input	24 V DC 2CO	24 V AC 2CO	115 V AC 2CO	230 V AC 2CO
Rated voltage	24 V DC	24 V AC	115 V AC	230 V AC
Rated current AC		31.6 mA	6.6 mA	3.2 mA
Rated current DC	16.7 mA			
Power rating	400 mW	0.75 VA	0.75 VA	0.75 VA
AC Response/dropout Volt		18.0 V / 3.6 V	86.3 V / 17.3 V	172.5 V / 34.5 V
DC Response/dropout Volt	16.8 V / 2.4 V			
Coil resistance	1440 Ω ±10%	350 Ω ±10%	8100 Ω ±15%	32500 Ω ±15%

**Ordering data
Complete module**

	Type	RCIKITP 24VDC 2CO LD/PB	RCIKITP 24VAC 2CO LD/PB	RCIKITP115VAC 2CO LD/PB	RCIKITP230VAC 2CO LD/PB
with test button	Order No.	8897230000	8897240000	8897250000	8897260000
without test button	Type	RCIKITP 24VDC 2CO LD	RCIKITP 24VAC 2CO LD	RCIKITP 115VAC 2CO LD	RCIKITP 230VAC 2CO LD
	Order No.	8897150000	8897160000	8897170000	8897180000

**Ordering data
Spare relay, pluggable**

	w. test button		w.o. test button		w. test button		w.o. test button	
Type	RCI424AC4	RCI484AC4	RCI424R24	RCI484R24	RCI424S15	RCI484S15	RCI484T30	RCI424T30
Order No.	8870180000	8870320000	8870210000	8870350000	8870220000	8870360000	8870370000	8870230000

Note

Relays - RIDERSERIES

RCI relay
1 CO contact AC/DC coil

- 4000 VA switching capacity
- Stable plug-in connections
- Optional test button with latching function and inspection window
- Optional status indicator (AC red/ DC green)
- Optional protective suppressor circuit
- Identification of coils (AC red / DC blue)

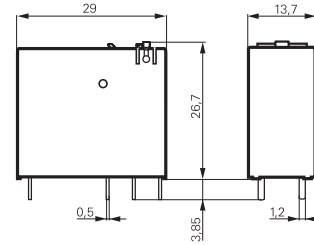

C

Circuit diagram
View on solder pins
dimensions in mm

1 C/O changeover contacts

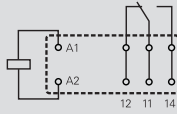

Output	
max. switching voltage AC1	250 V
Continuous current	16 A
Contact base material	AgNi 90/10
Mechanical endurance	AC coil 5*10 ⁶ / DC coil 10*10 ⁶ switching operations
Response time / Drop-out time	7 ms / 3 ms
Rated data	
Status indicator / Free wheel diode	see ordering data
Ambient temperature (operational)	-40 °C...+70 °C
UL 94 flammability rating	V-0
Approvals	cURus; VDE; CE;
Insulation coordination (IEC 60664)	
Rated voltage	250 V
Clearance and creepage distances for control/load side	8 mm
Surge category	III
Pollution severity	3
Protective separation to VDE 0106 part 101	Yes
Dimensions	
Length x width x height	mm 29 / 13.7 / x
Plug-in connection	
Note	x = 25.5 without test button / 26.7 with test button

Applications

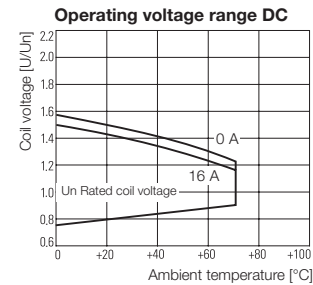
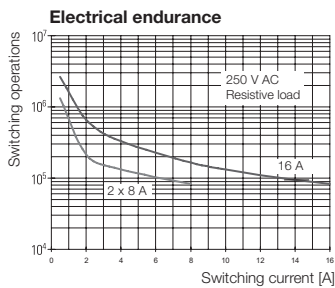
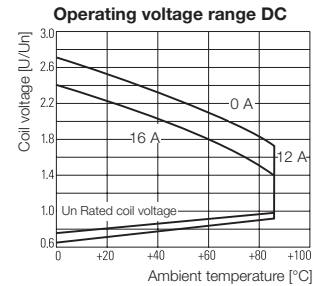
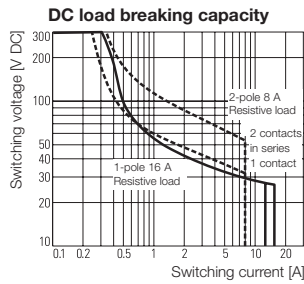

RCI relay
1 CO contact AC/DC coil

Type code	RCI				
Type	RIDER Control Industrial				
Type of construction	3 1-pole, 16 A 4 2-pole, 8 A				
Type of contact	1 1 CO contact without test button 2 2 CO contacts without test button 7 1 CO contact with test button 8 2 CO contacts with test button				
Contact material	4 AgNi 90/10				
Coil	012 12 V DC 024 24 V DC 048 48 V DC 110 110 V DC 524 24 V AC 615 115 V AC 730 230 V AC AB2 12 V DC+LED+diode AC4 24 V DC+LED+diode AE8 48 V DC+LED+diode BB0 110 V DC+LED+diode R24 24 V AC+LED S15 115 V AC+LED T30 230 V AC+LED				

Ordering data

Input	12 V DC 1CO	24 V DC 1CO	48 V DC 1CO	110 V DC 1CO
Rated voltage	12 V DC	24 V DC	48 V DC	110 V DC
DC Response/dropout Volt	8.4 V / 1.2 V	16.8 V / 2.4 V	33.6 V / 4.8 V	77 V / 11 V
Power rating	400 mW	400 mW	400 mW	400 mW
Rated current DC	33.3 mA	16.7 mA	8.7 mA	4.1 mA
Coil resistance	360 Ω ±10%	1440 Ω ±10%	5520 Ω ±10%	26600 Ω ±12%

Ordering data Relay

Standard	Type	12 V DC 1CO	24 V DC 1CO	48 V DC 1CO	110 V DC 1CO
	Order No.	8869800000	8869810000	8869820000	8869830000
with test button	Type	RCI374012	RCI374024	RCI374048	RCI374110
	Order No.	8869950000	8869960000	8869970000	8869980000
with LED + protective diode*	Type	RCI314AB2	RCI314AC4	RCI314AE8	RCI314BB0
	Order No.	8870090000	8870100000	8870110000	8870120000
with test button + LED + protective diode*	Type	RCI374AB2	RCI374AC4	RCI374AE8	RCI374BB0
	Order No.	8870240000	8870250000	8870260000	8870270000

Note
*Protective diode only with DC input

Ordering data

Input	24 V AC 1CO	115 V AC 1CO	230 V AC 1CO
Rated voltage	24 V AC	115 V AC	230 V AC
AC Response/dropout Volt	18.0 V / 3.6 V	86.3 V / 17.3 V	172.5 V / 34.5 V
Power rating	0.75 VA	0.75 VA	0.75 VA
Rated current AC		6.6 mA	3.2 mA
Coil resistance	350 Ω ±10%	8100 Ω ±15%	32500 Ω ±15%

Ordering data Relay

Standard	Type	24 V AC 1CO	115 V AC 1CO	230 V AC 1CO
	Order No.	8869840000	8869850000	8869860000
with test button	Type	RCI374524	RCI374615	RCI374730
	Order No.	8869990000	8870000000	8870010000
with LED	Type	RCI314R24	RCI314S15	RCI314T30
	Order No.	8870130000	8870140000	8870150000
with test button + LED	Type	RCI374R24	RCI374S15	RCI374T30
	Order No.	8870280000	8870290000	8870300000

Note

Relays - RIDERSERIES

RCI relay 2 CO contact AC/DC coil

- 2000 VA switching capacity
- Stable plug-in connections
- Optional test button with latching function and inspection window
- Optional status indicator (AC red / DC green)
- Optional protective suppressor circuit
- Identification of coils (AC red / DC blue)

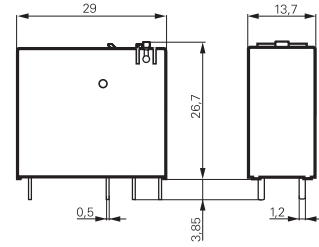

C

Circuit diagram

View on solder pins
dimensions in mm

2 C/O changeover contacts

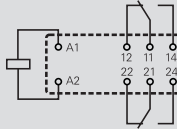

Output

max. switching voltage AC1	250 V
Continuous current	8 A / 1 contact
Contact base material	AgNi 90/10
Mechanical endurance	AC coil 5*10 ⁶ / DC coil 10*10 ⁶ switching operations
Response time / Drop-out time	7 ms / 2 ms

Rated data

Status indicator / Free wheel diode	see ordering data
Ambient temperature (operational)	-40 °C...+70 °C
UL 94 flammability rating	V-0
Approvals	cURus; VDE;

Insulation coordination (IEC 60664)

Rated voltage	250 V
Clearance and creepage distances for control/load side	8 mm
Surge category	III
Pollution severity	3
Protective separation to VDE 0106 part 101	Yes

Dimensions

Length x width x height mm 29 / 13.7 / x

Plug-in connection

Note x = 25.5 without test button / 26.7 with test button

Applications

DC load breaking capacity

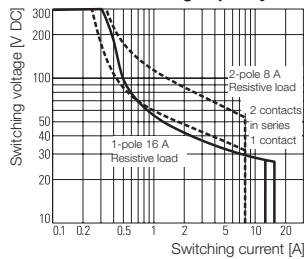

Operating voltage range DC

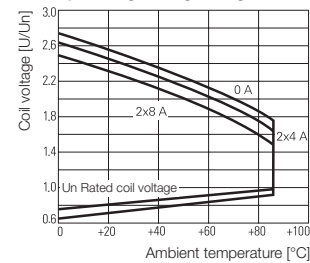

Electrical endurance

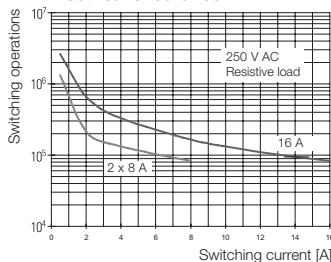

Operating voltage range DC

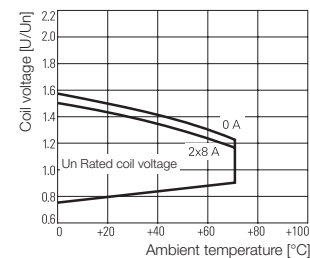

RCI relay
2 CO contact AC/DC coil

Type code	RCI				
Type	RIDER Control Industrial				
Type of construction	3 1-pole, 16 A 4 2-pole, 8 A				
Type of contact	1 1 CO contact without test button 2 2 CO contacts without test button 7 1 CO contact with test button 8 2 CO contacts with test button				
Contact material	4 AgNi 90/10				
Coil	012 12 V DC 024 24 V DC 048 48 V DC 110 110 V DC 524 24 V AC 615 115 V AC 730 230 V AC AB2 12 V DC+LED+diode AC4 24 V DC+LED+diode AE8 48 V DC+LED+diode BB0 110 V DC+LED+diode R24 24 V AC+LED S15 115 V AC+LED T30 230 V AC+LED				

Ordering data

Input	12 V DC 2CO	24 V DC 2CO	48 V DC 2CO	110 V DC 2CO
Rated voltage	12 V DC	24 V DC	48 V DC	110 V DC
DC Response/dropout Volt	8.4 V / 1.2 V	16.8 V / 2.4 V	33.6 V / 4.8 V	77 V / 11 V
Power rating	400 mW	400 mW	400 mW	400 mW
Rated current DC	33.3 mA	16.7 mA	8.7 mA	4.1 mA
Coil resistance	360 Ω ±10%	1440 Ω ±10%	5520 Ω ±10%	26600 Ω ±12%

Ordering data Relay				
Standard Type	RCI424012	RCI424024	RCI424048	RCI424110
Order No.	8869870000	8869890000	8869900000	8869910000
with test button Type	RCI484012	RCI484024	RCI484048	RCI484110
Order No.	8870020000	8870030000	8870040000	8870050000
with LED + protective diode* Type	RCI424AB2	RCI424AC4	RCI424AE8	RCI424BB0
Order No.	8870170000	8870180000	8870190000	8870200000
with test button + LED + protective diode* Type	RCI484AB2	RCI484AC4	RCI484AE8	RCI484BB0
Order No.	8870310000	8870320000	8870330000	8870340000
Note	*Protective diode only with DC input			

Ordering data

Input	24 V AC 2CO	115 V AC 2CO	230 V AC 2CO	
Rated voltage	24 V AC	115 V AC	230 V AC	
AC Response/dropout Volt	18 V / 3.6 V	86.3 V / 17.3 V	172.5 V / 34.5 V	
Power rating	0.75 VA	0.75 VA	0.75 VA	
Rated current AC	31.6 mA	6.6 mA	3.2 mA	
Coil resistance	350 Ω ±10%	8100 Ω ±15%	32500 Ω ±15%	

Ordering data Relay				
Standard Type	RCI424524	RCI424615	RCI424730	
Order No.	8869920000	8869930000	8869940000	
with test button Type	RCI484524	RCI484615	RCI484730	
Order No.	8870060000	8870070000	8870080000	
with LED Type	RCI424R24	RCI424S15	RCI424T30	
Order No.	8870210000	8870220000	8870230000	
with test button + LED Type	RCI484R24	RCI484S15	RCI484T30	
Order No.	8870350000	8870360000	8870370000	
Note				

Accessories for RCI relays
Plug-in module with screw or Push In connection

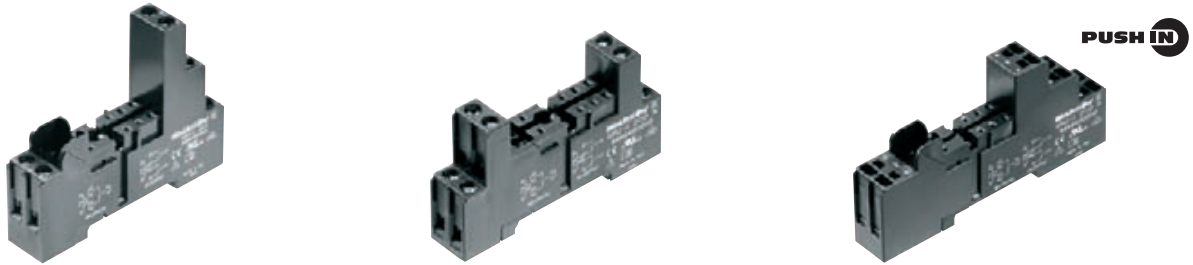

Ordering data

Description
Plug-in module with screw connections (only for RCL relays), pitch 3.5 mm, snaps onto DIN mounting rail, 1-pole
Plug-in module with screw connections, pitch 5 mm, snaps onto DIN mounting rail, 2-pole
Plug-in module with screw connections, pitch 5 mm, snaps onto DIN mounting rail, 2-pole
Plug-in module with Push In connections, pitch 5 mm, snaps onto DIN mounting rail, 2-pole

Type	Qty.	Order No.
SRC-I 1CO	10	8869470000
SRC-I 2CO	10	8869490000
SRC-I 2CO N	10	8869480000
SRC-I 2CO P	10	8869500000

Technical data

Nominal current	1-pole 2-pole	12 A 2 x 12 A*)
Nominal voltage		240 V~
Dielectric strength, screw/Push In connection		>3000 Veff / 4000 Veff
Ambient temperature		-25 °C ... +85 °C
Ingress protection		IP 20
Connection cross-section (screw connection) / with ferrules		2 x 2.5 mm ² / 2 x 1.5 mm ²
Connection cross-section (Push In conn.) / with ferrules		2 x 1.5 mm ² / 2 x 1.0 mm ²
Terminal torque / max.		0.5 Nm / 0.7 Nm

*) With 1-pole relays (16 A), the following terminal connections are required: 11 with 21, 12 with 22, 14 with 24.

Insulation according to IEC 60644-1

Rated voltage	250 V
Pollution severity	2
Surge category	III

Accessories

Description
Plastic retaining
Marking tag
Multicard 6 x 15 mm
Cross-connection for push-in base, 2-pole

Type	Qty.	Order No.
SRC-I CLIP HP	10	8869510000
SRC-I MARK	10	8869530000
ESG 6/15 K MC NEUTR. WS	200	1880100000
SRC-I QV	10	8870840000

LED and protection modules for SRC-I

Plug simply into the base module; reverse-connect protection. Connect parallel to coil.

Ordering data

Description
Free Wheel diode 1N4007
Resistor 62 kOhm 1 Watt
RC element 6 ... 60 V AC
RC element 110 ... 230 V AC
Varistor protection 24 V
Varistor protection 110 V
Varistor protection 230 V
LED
LED 6 ... 24 V DC with free wheel diode
LED 24 ... 60 V DC with free wheel diode
LED 110 ... 230 V DC with free wheel diode
LED 6 ... 24 V DC / V AC
LED 24 ... 60 V DC / V AC
LED 110 ... 230 V DC / V AC

Type	Qty.	Order No.	Order No.
RIM-I 1 6/230V	10	8869580000	
RIM-I 1 R 110/230V	10	8870830000	
RIM-I 3 6/60VAC	10	8869770000	
RIM-I 3 110/230VAC	10	8869790000	
RIM-I 4 24VUC	10	8869710000	
RIM-I 4 110VUC	10	8869730000	
RIM-I 4 230VUC	10	8869750000	
		red	green
RIM-I 2 6/24VDC	10	8869590000	8869600000
RIM-I 2 24/60VDC	10	8869670000	8869680000
RIM-I 2 110/230VDC	10	8869690000	8869700000
RIM-I 3 6/24VUC	10	8869630000	8869640000
RIM-I 3 24/60VUC	10	8869610000	8869620000
RIM-I 3 110/230VUC	10	8869650000	8869660000

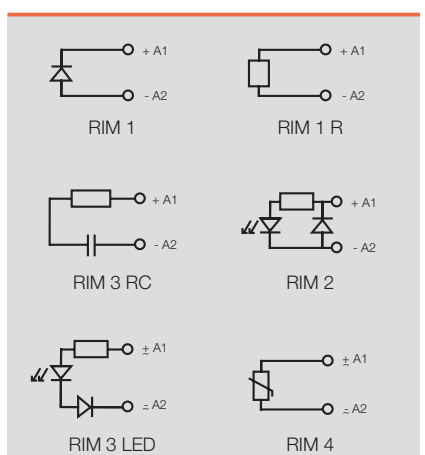
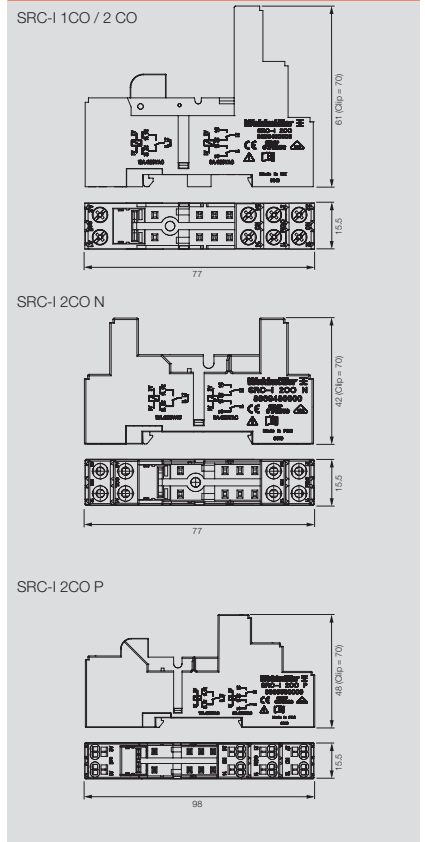

Relays - RIDERSERIES

RCM KIT 2 CO contact AC/DC coil

Modular system comprised of:

- relay socket for rail mounting
 - LED display unit (AC red / DC green)
 - retaining clip
 - plug-in relay
 - Markers
 - Coil identification (AC red / DC blue)
- Independent connection system
- Screw or Push-In connection system

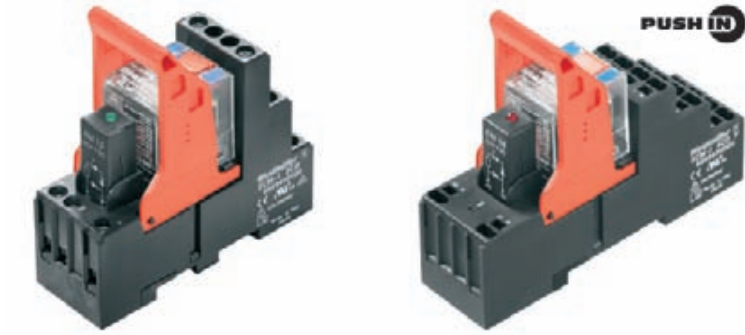

Output	
max. switching voltage AC1	250 V
Continuous current	12 A
Contact base material	AgNi 90/10
Mechanical endurance	AC coil 20*10 ⁶ / DC coil 30*10 ⁶ switching operations
Response time / Drop-out time	15ms / 10ms
Rated data	
Status indicator/Free wheel diode	Green LED = DC coil; red LED = AC coil/Yes
Ambient temperature (operational)	-40 °C...+70 °C
UL 94 flammability rating	V-0
Approvals	CE, GL
Insulation coordination (IEC 60664)	
Rated voltage	240 V
Clearance and creepage distances for control/load side	≤ 4mm
Surge category	III
Pollution severity	2
Note	

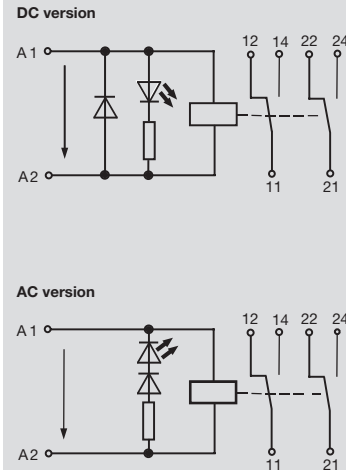

	Screw connection	Push-In connection
Clamping range (rating- / min. / max.)	mm ² 2.5 / 0.5 / 2.5	1.5 / 0.5 / 1.5
Length x width x height	mm 75 / 28 / 82	96 / 28 / 98

Ordering data

Input	24 V DC 2CO LED	24 V AC 2CO LED	115 V AC 2CO	230 V AC 2CO LED
Rated voltage	24 V DC	24 V AC	115 V AC	230 V AC
Rated current AC		41.6 mA	8.8 mA	4.3 mA
Rated current DC	31.3 mA			
Power rating	750 mW	1.0 VA	1.0 VA	1.0 VA
AC Response/dropout Volt		19.2 V / 7.2 V	92 V / 34.5 V	184.0 V / 69.0 V
DC Response/dropout Volt	18.0 V / 2.4 V			

Ordering data Complete module

Connection	Type	24 V DC 2CO LED	24 V AC 2CO LED	115 V AC 2CO	230 V AC 2CO LED
Screw connection	Type	RCMKIT-I 24VDC 2CO LD	RCMKIT-I 24VAC 2CO LD	RCMKIT-I 115VAC 2CO LD	RCMKIT-I 230VAC 2CO LD
	Order No.	8920940000	8920950000	8920960000	8920970000
Push-In connection	Type	RCMKITP-I 24VDC 2CO LD	RCMKITP-I 24VAC 2CO LD	RCMKITP-I 115VAC 2CO LD	RCMKITP-I 230VAC 2CO LD
	Order No.	8921080000	8921090000	8921100000	8921110000

Ordering data Spare relay, pluggable

Type	24 V DC 2CO LED	24 V AC 2CO LED	115 V AC 2CO	230 V AC 2CO LED
Type	RCM270024	RCM270524	RCM270615	RCM270730
Order No.	8689860000	8689760000	8689800000	8689820000

Note

RCM KIT 3 CO contact AC/DC coil

Modular system comprised of:

- relay socket for rail mounting
- LED display unit (AC red / DC green)
- retaining clip
- plug-in relay
- Markers
- Identification of coils (AC red / DC blue)

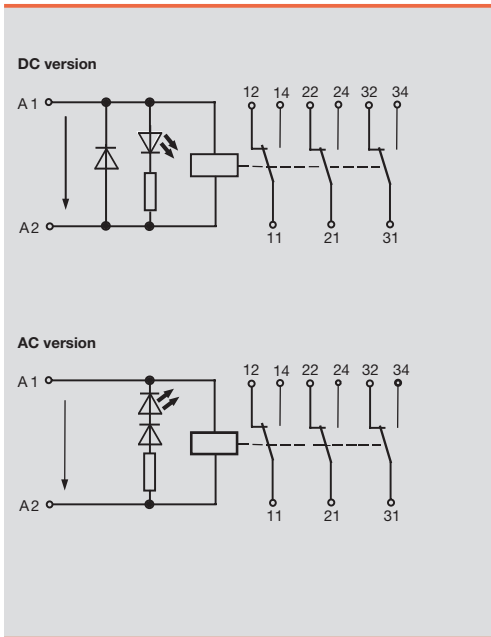

Output		
max. switching voltage AC1	250 V	
Continuous current	10 A	
Contact base material	AgNi 90/10	
Mechanical endurance	AC coil 20*10 ⁶ / DC coil 30*10 ⁶ switching operations	
Response time / Drop-out time	15ms / 10ms	
Rated data		
Status indicator/Free wheel diode	Green LED = DC coil; red LED = AC coil/Yes	
Ambient temperature (operational)	-40 °C...+70 °C	
UL 94 flammability rating	V-0	
Approvals	CE, GL	
Insulation coordination (IEC 60664)		
Rated voltage	240 V	
Clearance and creepage distances for control/load side	≤ 4mm	
Surge category	III	
Pollution severity	2	
Screw connection		Push-In connection
Clamping range (rating- / min. / max.)	mm ²	2.5 / 0.5 / 2.5
Length x width x height	mm	75 / 28 / 82
Note		

Ordering data

Input	24 V DC 3CO LED	24 V AC 3CO LED	115 V AC 3CO LED	230 V AC 3CO LED
Rated voltage	24 V DC	24 V AC	115 V AC	230 V AC
Rated current AC		41.6 mA	8.8 mA	4.3 mA
Rated current DC	31.3 mA			
Power rating	750 mW	1.0 VA	1.0 VA	1.0 VA
AC Response/dropout Volt		19.2 V / 7.2 V	92 V / 34.5 V	184.0 V / 69.0 V
DC Response/dropout Volt	18.0 V / 2.4 V			

Ordering data Complete module

		24 V DC 3CO LED	24 V AC 3CO LED	115 V AC 3CO LED	230 V AC 3CO LED
Screw connection	Type	RCMKIT-I 24VDC 3CO LD	RCMKIT-I 24VAC 3CO LD	RCMKIT-I 115VAC 3CO LD	RCMKIT-I 230VAC 3CO LD
	Order No.	8920980000	8920990000	8921010000	8921020000
Push-In connection	Type				
	Order No.				

Ordering data Spare relay, pluggable

Type	RCM370024	RCM370524	RCM370615	RCM370730
Order No.	8690040000	8690030000	8689980000	8690000000

Note

Accessories for miniature relays RCM-I
Plug-in module with screw or Push In connection



Ordering data

Description
Plug-in module with screw connections, snap-on installation, 2-pole
Plug-in module with screw connections, snap-on installation, 3-pole
Plug-in module with screw connections, snap-on installation, 4-pole
Plug-in module with screw connections, snaps onto DIN mounting rails, 4-pole
Plug-in module with Push In connections, snaps onto DIN mounting rails, 2-pole
Plug-in module with Push In connections, snaps onto DIN mounting rails, 4-pole

Type	Qty.	Order No.
SCM-I 2CO	10	8869400000
SCM-I 3CO N	10	8869410000
SCM-I 4CO	10	8869420000
SCM-I 4CO N	10	8869390000
SCM-I 2CO P	10	8876220000
SCM-I 4CO P	10	8869430000

Dimensions in mm

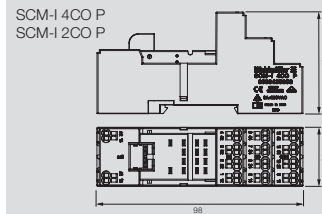
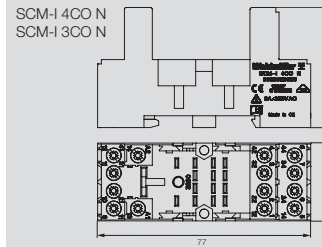
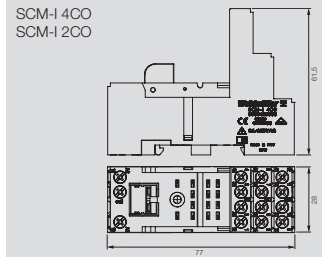

Technical data

Nominal current	4-pole 6 A, 3-pole 10 A, 2-pole 12 A
Nominal voltage	300 V AC
Dielectric strength, coil/contacts	> 2500 Veff
Insulation group (VDE 0110b)	C / 250 V AC
Ambient temperature	-45 ... +70 °C ¹⁾
Protection class (IEC 61810)	IP 20
Connection cross-section (Push In connections) / with ferrules	2 x 1.5 mm ² / 2 x 1.0 mm ²
Connection cross-section (screw connections) / with ferrules	2 x 2.5 mm ² / 2 x 1.5 mm ²
Terminal torque (screw connection)	0.5 Nm
Max.	0.7 Nm

¹⁾ At nominal current up to +40 °C, up to +70 °C at 70 %

Accessories

Description
Plastic retaining clip
Metal retaining clip
Markers, individual
Markers, MultiCard
Cross-connection for push-in base, 2-pole, 12 A

Type	Qty.	Order No.
SCM-I CLIP P	10	8869440000
SCM-I CLIP N	10	8875620000
SCM-I CLIP M	10	8869450000
SCM-I MARK	10	8869460000
ESG 9/11 K MC neutral	200	1857440000
SCM-I QV	10	8870850000

LED and protection modules for SCM-I

Plug simply into the base module; reverse-connect protection. Connect parallel to coil.

Ordering data

Description
Free Wheel diode 1N4007
Resistor 62 kOhm 1 Watt
RC element 6 ... 60 V AC
RC element 110 ... 230 V AC
Varistor protection 24 V
Varistor protection 110 V
Varistor protection 230 V
LED
LED 6 ... 24 V DC with free wheel diode
LED 24 ... 60 V DC with free wheel diode
LED 110 ... 230 V DC with free wheel diode
LED 6 ... 24 V DC / V AC
LED 24 ... 60 V DC / V AC
LED 110 ... 230 V DC / V AC

Type	Qty.	Order No.	Order No.
RIM-I 1 6/230V	10	8869580000	
RIM-I 1 R 110/230V	10	8870830000	
RIM-I 3 6/60VAC	10	8869770000	
RIM-I 3 110/230VAC	10	8869790000	
RIM-I 4 24VUC	10	8869710000	
RIM-I 4 110VUC	10	8869730000	
RIM-I 4 230VUC	10	8869750000	
		red	green
RIM-I 2 6/24VDC	10	8869590000	8869600000
RIM-I 2 24/60VDC	10	8869670000	8869680000
RIM-I 2 110/230VDC	10	8869690000	8869700000
RIM-I 3 6/24VUC	10	8869630000	8869640000
RIM-I 3 24/60VUC	10	8869610000	8869620000
RIM-I 3 110/230VUC	10	8869650000	8869660000

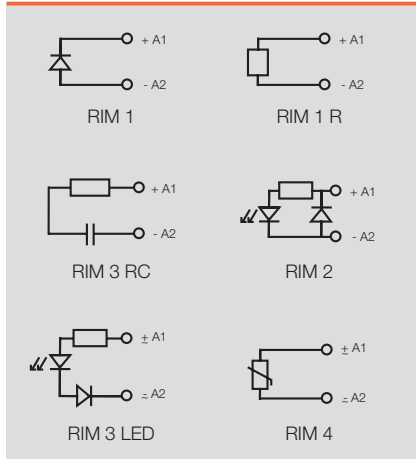

Relays - RIDERSERIES

**RCM relay
2 CO contact
AC/DC coil**

- 3000 VA switching capacity
- Solder and plug connection
- Safe-to-touch test button, selectable locking
- White labelling panel
- Identification of coils (AC red / DC) blue

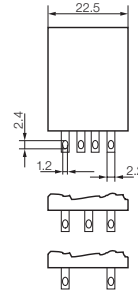

C

Circuit diagram
View of connections
Dimensions in mm

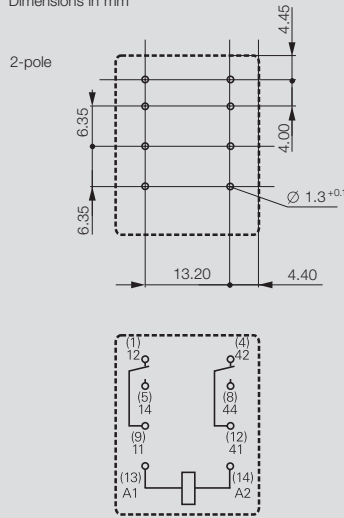

Output	
max. switching voltage AC1	250 V
Continuous current	12 A
Contact base material	AgNi 90/10
Mechanical endurance	AC coil 20*10 ⁶ / DC coil 30*10 ⁶ switching operations
Response time / Drop-out time	15ms / 10ms
Rated data	
Status indicator / Free wheel diode	see ordering data
Ambient temperature (operational)	-40 °C...+70 °C
UL 94 flammability rating	V-0
Approvals	cURus; CE; VDE;
Insulation coordination (IEC 60664)	
Rated voltage	240 V
Clearance and creepage distances for control/load side	≤ 4mm
Surge category	III
Pollution severity	3
Dimensions	
Length x width x height	mm 28 / 22.5 / 29
Note	

Applications

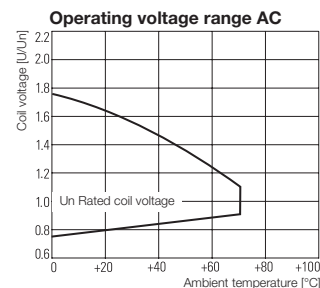
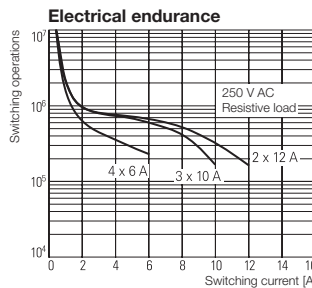
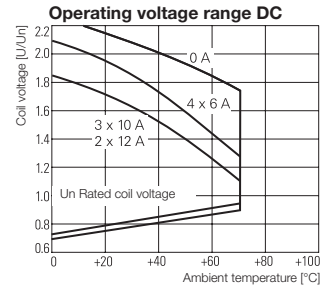
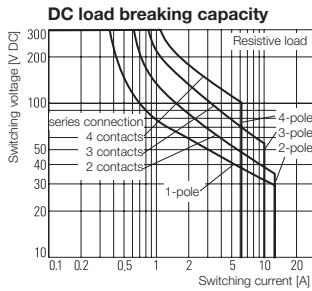

**RCM relay
2 CO contact
AC/DC coil**

Type code

Type RIDER Control Multiple

Contacts

- 2 2 CO contacts
- 3 3 CO contacts
- 5 4 CO contacts

Contact material

- 7 AgNi 90/10, with test button
- 8 AgNi 90/10 hgp, with test button

Type of construction

- 0 Standard, 2.8 mm Faston

DC coil

006	6 V DC	L06	
012	12 V DC	L12	AB2
024	24 V DC	L24	AC4
048	48 V DC	L48	AE8
060	60 V DC	L60	
110	110 V DC	M10	BB0
220	220 V DC	N20	

AC coil

506	6 V AC	R06	
512	12 V AC	R12	
524	24 V AC	R24	
548	48 V AC	R48	
615	115 V AC	S15	
730	230 V AC	T30	

Ordering data

Input	12 V DC 2CO	24 V DC 2CO	48 V DC 2CO	110 V DC 2CO
Rated voltage	12 V DC	24 V DC	48 V DC	110 V DC
DC Response/dropout Volt	9.0 V / 1.2 V	18.0 V / 2.4 V	36.0 V / 4.8 V	82.5 V / 11.0 V
Power rating	750 mW	750 mW	750 mW	750 mW
Rated current DC	62.5 mA	31.3 mA	15.6 mA	6.8 mA
Coil resistance	192 Ω ±10%	777 Ω ±10%	3072 Ω ±10%	16133 Ω ±15%

Ordering data Relay

without LED	Type	RCM270012	RCM270024	RCM270048	RCM270110
AgNi 90/10	Order No.	8689840000	8689860000	8689880000	8689900000
with LED	Type	RCM270L12	RCM270L24	RCM270L48	RCM270M10
AgNi 90/10	Order No.	8689850000	8689870000	8689890000	8689910000
with LED + Diode	Type	RCM270AB2	RCM270AC4	RCM270AE8	RCM270BB0
AgNi 90/10	Order No.	8957020000	8957030000	8957040000	8957050000

Note

Ordering data

Input	24 V AC 2CO	48 V AC 2CO	115 V AC 2CO	230 V AC 2CO
Rated voltage	24 V AC	48 V AC	115 V AC	230 V AC
AC Response/dropout Volt	38.4 V / 14.4 V	48.0 V / 18.0 V	92.0 V / 34.5 V	184.0 V / 69.0 V
Power rating	1.0 VA	1.0 VA	1.0 VA	1.0 VA
Rated current AC	41.6 mA	21.3 mA	8.8 mA	4.3 mA
Coil resistance	192 Ω ±10%	777 Ω ±10%	4845 Ω ±12%	19465 Ω ±15%

Ordering data Relay

without LED	Type	RCM270524	RCM270548	RCM270615	RCM270730
AgNi 90/10	Order No.	8689760000	8689780000	8689800000	8689820000
with LED	Type	RCM270R24	RCM270R48	RCM270S15	RCM270T30
AgNi 90/10	Order No.	8689770000	8689790000	8689810000	8689830000
	Type				
	Order No.				

Note

Relays - RIDERSERIES

**RCM relay
3 CO contact
AC/DC coil**

- 2500 VA switching capacity
- Solder and plug connection
- Safe-to-touch test button, selectable locking
- White labelling panel
- Identification of coils (AC red / DC blue)

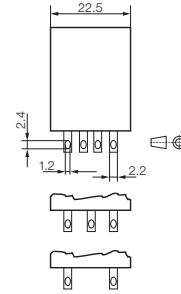

C

Circuit diagram

View of connections
Dimensions in mm

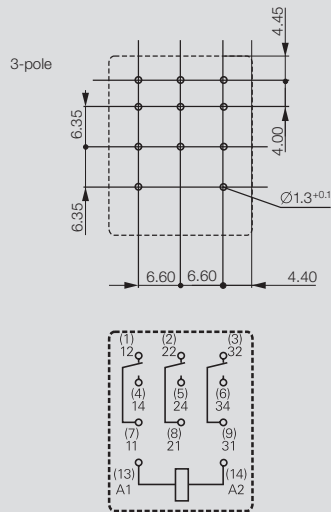

Output	
max. switching voltage AC1	250 V
Continuous current	10 A
Contact base material	AgNi 90/10
Mechanical endurance	AC coil 20*10 ⁶ / DC coil 30*10 ⁶ switching operations
Response time / Drop-out time	15ms / 10ms
Rated data	
Status indicator / Free wheel diode	see ordering data
Ambient temperature (operational)	-40 °C...+70 °C
UL 94 flammability rating	V-0
Approvals	cURus; CE; VDE;
Insulation coordination (IEC 60664)	
Rated voltage	240 V
Clearance and creepage distances for control/load side	≤ 4mm
Surge category	III
Pollution severity	3
Dimensions	
Length x width x height	mm 28 / 22.5 / 29
Note	

Applications

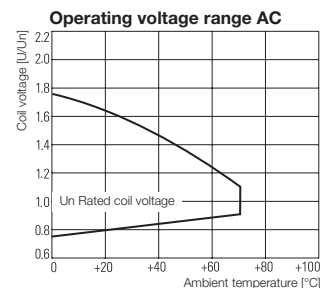
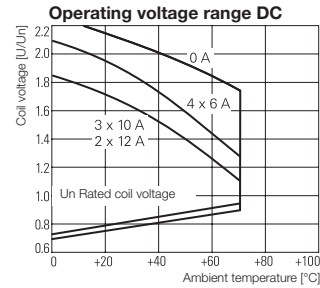
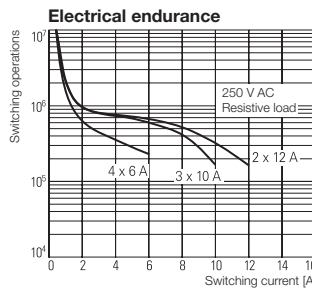
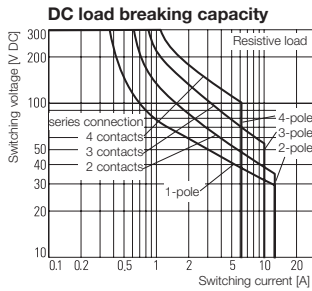

**RCM relay
3 CO contact
AC/DC coil**

Type code

Type RIDER Control Multiple

Contacts

- 2 2 CO contacts
- 3 3 CO contacts
- 5 4 CO contacts

Contact material

- 7 AgNi 90/10, with test button
- 8 AgNi 90/10 hgp, with test button

Type of construction

- 0 Standard, 2.8 mm Faston

DC coil

006	6 V DC	L06	with LED + diode
012	12 V DC	L12	LED
024	24 V DC	L24	AB2
048	48 V DC	L48	AC4
060	60 V DC	L60	AE8
110	110 V DC	M10	BB0
220	220 V DC	N20	

AC coil

506	6 V AC	R06	
512	12 V AC	R12	
524	24 V AC	R24	
548	48 V AC	R48	
615	115 V AC	S15	
730	230 V AC	T30	

Ordering data

Input

	12 V DC 3CO	24 V DC 3CO	48 V DC 3CO	110 V DC 3CO
Rated voltage	12 V DC	24 V DC	48 V DC	110 V DC
DC Response/dropout Volt	9.0 V / 1.2 V	18.0 V / 2.4 V	36.0 V / 4.8 V	82.5 V / 11.0 V
Power rating	750 mW	750 mW	750 mW	750 mW
Rated current DC	62.5 mA	31.3 mA	15.6 mA	6.8 mA
Coil resistance	192 Ω ±10%	777 Ω ±10%	3072 Ω ±10%	16133 Ω ±15%

**Ordering data
Relay**

	12 V DC 3CO	24 V DC 3CO	48 V DC 3CO	110 V DC 3CO
without LED Type	RCM370012	RCM370024	RCM370048	RCM370110
AgNi 90/10 Order No.	8690020000	8690040000	8690060000	8690080000
with LED Type	RCM370L12	RCM370L24	RCM370L48	RCM370M10
AgNi 90/10 Order No.	8694310000	8690050000	8689940000	8690090000
with LED + Diode Type	RCM370AB2	RCM370AC4	RCM370AE8	RCM370BB0
AgNi 90/10 Order No.	8957090000	8957100000	8957110000	8957120000

Note

Ordering data

Input

	24 V AC 3CO	48 V AC 3CO	115 V AC 3CO	230 V AC 3CO
Rated voltage	24 V AC	48 V AC	115 V AC	230 V AC
AC Response/dropout Volt	19.2 V / 7.2 V	38.4 V / 14.4 V	92.0 V / 34.5 V	184.0 V / 69.0 V
Power rating	1.0 VA	1.0 VA	1.0 VA	1.0 VA
Rated current AC	41.6 mA	21.3 mA	8.8 mA	4.3 mA
Coil resistance	192 Ω ±10%	777 Ω ±10%	4845 Ω ±12%	19465 Ω ±15%

**Ordering data
Relay**

	24 V AC 3CO	48 V AC 3CO	115 V AC 3CO	230 V AC 3CO
without LED Type	RCM370524		RCM370615	RCM370730
AgNi 90/10 Order No.	8690030000		8689980000	8690000000
with LED Type	RCM370R24	RCM370R48	RCM370S15	RCM370T30
AgNi 90/10 Order No.	8689950000	8689970000	8689990000	8690010000
Type Order No.				

Note

Relays - RIDERSERIES

RCM relay 4 CO contact AC/DC coil

- 1500 VA switching capacity
- Solder and plug connection
- AC/DC versions also with gold-plated contacts
- Safe-to-touch test button, selectable locking
- White labelling panel
- Identification of coils (AC red / DC blue)

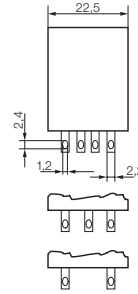

C

Circuit diagram

View of connections
Dimensions in mm

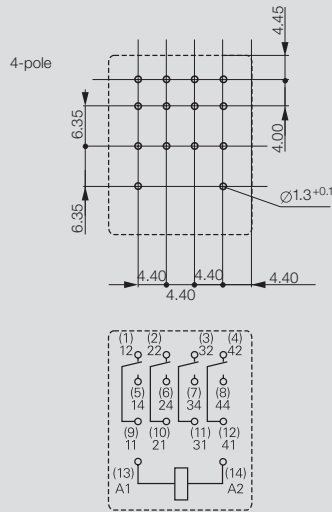

Output

max. switching voltage AC1	250 V
Continuous current	6 A
Contact base material	AgNi 90/10 or AgNi 5µm Au
Mechanical endurance	AC coil 20*10 ⁶ / DC coil 30*10 ⁶ switching operations
Response time / Drop-out time	15ms / 10ms

Rated data

Status indicator / Free wheel diode	see ordering data
Ambient temperature (operational)	-40 °C...+70 °C
UL 94 flammability rating	V-0
Approvals	cURus; CE; VDE;

Insulation coordination (IEC 60664)

Rated voltage	240 V
Clearance and creepage distances for control/load side	≤ 3mm
Surge category	III
Pollution severity	2

Dimensions

Length x width x height	mm	28 / 22.5 / 29
-------------------------	----	----------------

Note

Applications

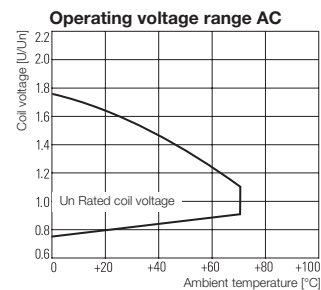
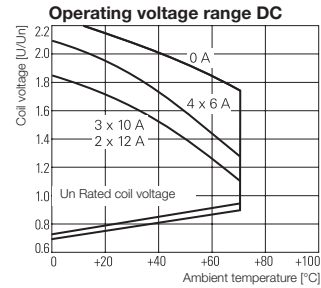
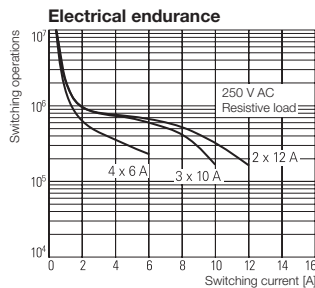
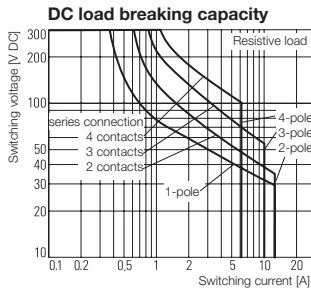

**RCM relay
4 CO contact
AC/DC coil**

Type code

Type RIDER Control Multiple

Contacts

- 2 2 CO contacts
- 3 3 CO contacts
- 5 4 CO contacts

Contact material

- 7 AgNi 90/10, with test button
- 8 AgNi 90/10 hgp, with test button

Type of construction

- 0 Standard, 2.8 mm Faston

DC coil

006	6 V DC	L06	
012	12 V DC	L12	AB2
024	24 V DC	L24	AC4
048	48 V DC	L48	AE8
060	60 V DC	L60	
110	110 V DC	M10	BB0
220	220 V DC	N20	

AC coil

506	6 V AC	R06	
512	12 V AC	R12	
524	24 V AC	R24	
548	48 V AC	R48	
615	115 V AC	S15	
730	230 V AC	T30	

Ordering data

Input	12 V DC 4CO	24 V DC 4CO	48 V DC 4CO	110 V DC 4CO
Rated voltage	12 V DC	24 V DC	48 V DC	110 V DC
DC Response/dropout Volt	9.0 V / 1.2 V	18 V / 2.4 V	36 V / 4.8 V	82.5 V / 11 V
Power rating	750 mW	750 mW	750 mW	750 mW
Rated current DC	62.5 mA	31,3 mA	15.6 mA	6.8 mA
Coil resistance	192 Ω ±10%	777 Ω ±10%	3072 Ω ±10%	16133 Ω ±15%

Ordering data Relay				
without LED Type	RCM570012	RCM570024	RCM570048	RCM570110
AgNi 90/10 Order No.	8054360000	8690200000	8074670000	8074700000
with LED Type	RCM570L12	RCM570L24	RCM570L48	RCM570M10
AgNi 90/10 Order No.	8690180000	8690220000	8690230000	8690240000
without LED Type	RCM580012	RCM580024	RCM580048	RCM580110
AgNi 5 µm Au Order No.	on request	8694460000	on request	8829000000
with LED + Diode Type	RCM470AB2	RCM470AC4	RCM470AE8	RCM470BB0
AgNi 90/10 Order No.	8957160000	8957170000	8957180000	8957190000

Note				

Ordering data

Input	24 V AC 4CO	48 V AC 4CO	115 V AC 4CO	230 V AC 4CO
Rated voltage	24 V AC	48 V AC	115 V AC	230 V AC
AC Response/dropout Volt	19,2 V / 7,2 V	38,4 V / 14,4 V	92 V / 34,5 V	184 V / 69 V
Power rating	1.0 VA	1.0 VA	1.0 VA	1.0 VA
Rated current AC	41,6 mA	21,3 mA	8,8 mA	4,3 mA
Coil resistance	192 Ω ±10%	777 Ω ±10%	4845 Ω ±12%	19465 Ω ±15%

Ordering data Relay				
without LED Type	RCM570524	RCM570548	RCM570615	RCM570730
AgNi 90/10 Order No.	8690110000	1180900000	1180800000	1181100000
with LED Type	RCM570R24	RCM570R48	RCM570S15	RCM570T30
AgNi 90/10 Order No.	8690120000	8690130000	8690150000	8690160000
without LED Type	RCM580524		RCM580615	RCM580730
AgNi 5µm Au Order No.	7940008171		8824860000	7940007637

Note				

Relays - RIDERSERIES

**RRD relay
2 CO contact
AC/DC coil**

- 2 change-over contacts
- 2500 VA switching capacity
- Mechanical operating indicator
- Safe-to-touch test button, selectable locking

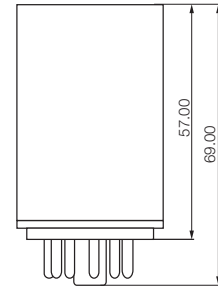
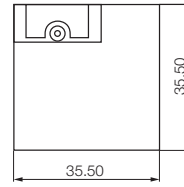

C

Circuit diagram

View of connections

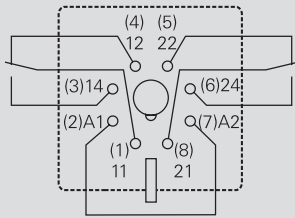

Output	
max. switching voltage AC1	250 V
Continuous current	10 A
Contact base material	AgNi 90/10
Mechanical endurance	20*10 ⁶ switching cycles
Response time / Drop-out time	12 ms / 5 ms
Rated data	
Status indicator/Free wheel diode	mechanical/no
Ambient temperature (operational)	-45 °C...+50 °C
UL 94 flammability rating	V-0
Approvals	cURus; CE; VDE;
Insulation coordination (IEC 60664)	
Rated voltage	250 V
Clearance and creepage distances for control/load side	≤ 4mm
Surge category	III
Pollution severity	3
Dimensions	
Length x width x height	mm 35,5 / 35,5 / 57
Note	

Applications

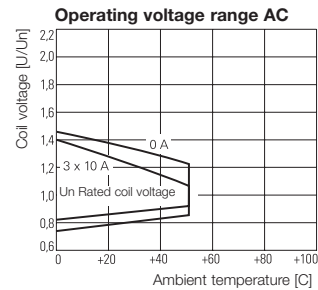
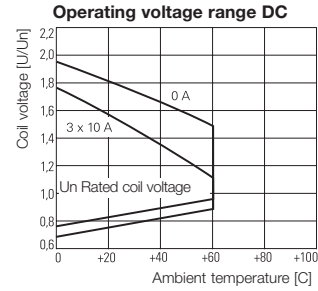
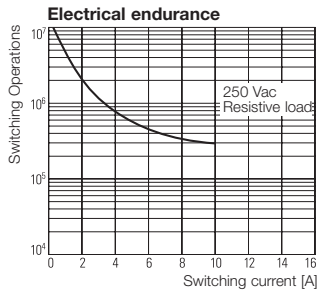
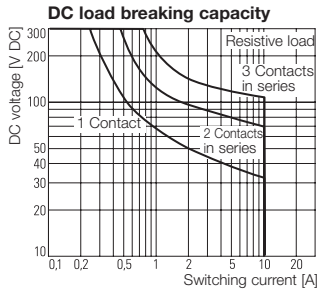

**RRD relay
2 CO contact
AC/DC coil**

Type code	RRD					
Type	RIDER Round					
Contacts	2 2 change-over contacts, 8-pole 3 3 change-over contacts, 11-pole					
Contact material	2 AgNi 90/10					
Type of construction	1 DC coil with test button 3 DC coil with test button and bi-polar LED 6 AC coil with test button 8 AC coil with test button and bi-polar LED					
DC coil	006 6 V DC 012 12 V DC 024 24 V DC 0C4 048 48 V DC 0E8 060 60 V DC 0G0 110 110 V DC 1B0 220 220 V DC 2C0					
AC coil	006 6 V AC 012 12 V AC 024 24 V AC 048 48 V AC 115 115 V AC 230 230 V AC					

Ordering data	24 V DC 2CO	48 V DC 2CO	110 V DC 2CO	220 V DC 2CO
Input				
Rated voltage	24 V DC	48 V DC	110 V DC	220 V DC
DC Response/dropout Volt	18.0 V / 2.4 V	36.0 V / 4.8 V	82.5 V / 11.5 V	165 V / 22 V
Power rating	1.2 W	1.2 W	1.2 W	1.2 W
Rated current DC	50.5 mA	24.0 mA	11.0 mA	5.5 mA
Coil resistance	475 Ω ±10%	2000 Ω ±10%	10000 Ω ±12%	40000 Ω ±15%

Ordering data Relay				
with test button Type	RRD221024	RRD221048	RRD221110	
AgNi 90/10 Order No.	8690370000	8690390000	8690410000	
with test button/LED Type	RRD223024	RRD223048	RRD223110	RRD223220
AgNi 90/10 Order No.	8690380000	8690400000	8690420000	8798600000
Type Order No.				

Note				

Ordering data	24 V AC 2CO	48 V AC 2CO	115 V AC 2CO	230 V AC 2CO
Input				
Rated voltage	24 V AC	48 V AC	115 V AC	230 V AC
AC Response/dropout Volt	19.2 V / 9.6 V	38.4 V / 19.2 V	92.0 V / 46.0 V	184.0 V / 92.0 V
Power rating	2.3 VA	2.3 VA	2.3 VA	2.3 VA
Rated current AC	94.2 mA	47.5 mA	20.6 mA	10.1 mA
Coil resistance	86 Ω ±10%	345 Ω ±10%	2000 Ω ±10%	8300 Ω ±12%

Ordering data Relay				
with test button Type	RRD226024	RRD226048	RRD226115	RRD226230
AgNi 90/10 Order No.	8690270000	8690290000	8690310000	8690330000
with test button/LED Type	RRD228024	RRD228048	RRD228115	RRD228230
AgNi 90/10 Order No.	8690280000	8690300000	8690320000	8690340000
Type Order No.				

Note				

Relays - RIDERSERIES

RRD relay
3 CO contact
AC/DC coil

- 3 change-over contacts
- 500 VA switching capacity
- Mechanical operating indicator
- Safe-to-touch test button, selectable locking

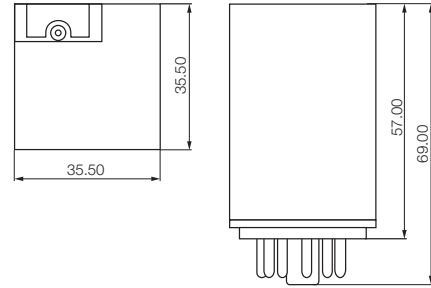

C

Circuit diagram

View of connections

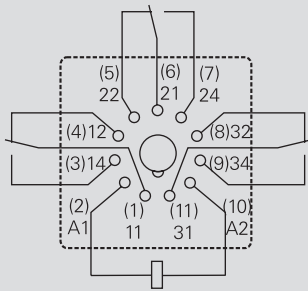

Output	
max. switching voltage AC1	250 V
Continuous current	10 A
Contact base material	AgNi 90/10
Mechanical endurance	20*10 ⁶ switching cycles
Response time / Drop-out time	
Rated data	
Status indicator/Free wheel diode	mechanical/
Ambient temperature (operational)	AC coil -45...+50°C / DC coil -45...+60°C
UL 94 flammability rating	V-0
Approvals	cURus; CE; VDE;
Insulation coordination (IEC 60664)	
Rated voltage	250 V
Clearance and creepage distances for control/load side	≤ 4mm
Surge category	III
Pollution severity	3
Dimensions	
Length x width x height	mm 35,5 / 35,5 / x
Note	

Applications

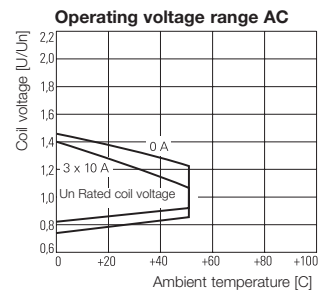
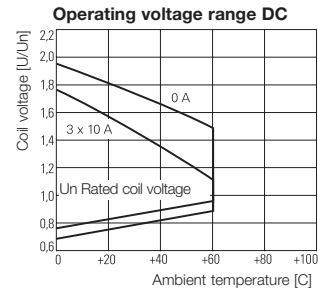
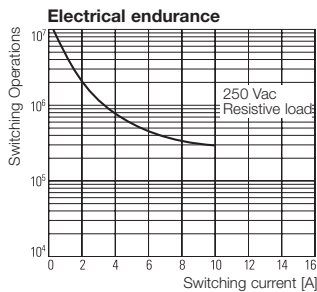
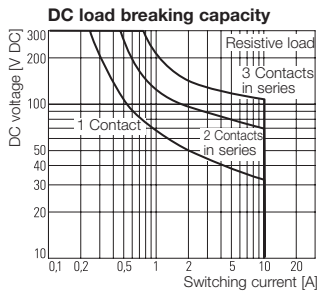

**RRD relay
3 CO contact
AC/DC coil**

Type code	RRD				
Type	RIDER Round				
Contacts	2 2 change-over contacts, 8-pole 3 3 change-over contacts, 11-pole				
Contact material	2 AgNi 90/10				
Type of construction	1 DC coil with test button 3 DC coil with test button and bi-polar LED 6 AC coil with test button 8 AC coil with test button and bi-polar LED				
DC coil	006 6 V DC 012 12 V DC 024 24 V DC 048 48 V DC 060 60 V DC 110 110 V DC 220 220 V DC				
AC coil	006 6 V AC 012 12 V AC 024 24 V AC 048 48 V AC 115 115 V AC 230 230 V AC				
Free wheel diode	OC4 OE8 OG0 1B0 2C0				

Ordering data

Input	12 V DC 3CO	24 V DC 3CO	110 V DC 3CO	220 V DC 3CO
Rated voltage	12 V DC	24 V DC	110 V DC	220 V DC
DC Response/dropout Volt	9 V / 1.2 V	18 V / 2.4 V	82.5 V / 11.5 V	165 V / 22 V
Power rating	1.2 W	1.2 W	1.2 W	1.2 W
Rated current DC	109.1 mA	50.5 mA	11 mA	5.5 mA
Coil resistance	110 Ω ±10%	475 Ω ±10%	10000 Ω ±12%	40000 Ω ±15%

Ordering data Relay	12 V DC 3CO	24 V DC 3CO	110 V DC 3CO	220 V DC 3CO
with test button Type	RRD321012	RRD321024	RRD321110	RRD321220
Order No.	8799030000	8690610000	8690650000	7940007742
with test button/LED Type		RRD323024	RRD323110	RRD323220
Order No.		8690620000	8690660000	8798610000
with test button Type		RRD3210C4	RRD3211B0	RRD3212C0
+ Free-wheel diode Order No.		8797650000	8797640000	8797610000
with test button/LED Type		RRD3230C4		RRD3232C0
+ Free-wheel diode Order No.		7940007732		8829400000
Note				

Ordering data

Input	24 V AC 3CO	48 V AC 3CO	115 V AC 3CO	230 V AC 3CO
Rated voltage	24 V AC	48 V AC	115 V AC	230 V AC
AC Response/dropout Volt	19.2 V / 9.6 V	38.4 V / 19.2 V	92 V / 46 V	184 V / 92 V
Power rating	2.3 VA	2.3 VA	2.3 VA	2.3 VA
Rated current AC	94.2 mA	47.5 mA	20.6 mA	10.1 mA
Coil resistance	86 Ω ±10%		2000 Ω ±10%	8300 Ω ±12%

Ordering data Relay	24 V AC 3CO	48 V AC 3CO	115 V AC 3CO	230 V AC 3CO
with test button Type	RRD326024	RRD326048	RRD326115	RRD326230
Order No.	8690450000	8690470000	8690550000	8690570000
with test button/LED Type	RRD328024	RRD328048	RRD328115	RRD328230
Order No.	8690460000	8690480000	8690560000	8690580000
Type				
Order No.				
Type				
Order No.				
Note				

Relays - RIDERSERIES

Accessories for RRD relays Plug-in module with screw connection



Dimensions in mm

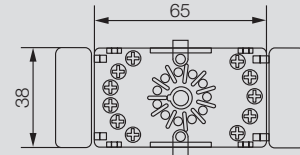
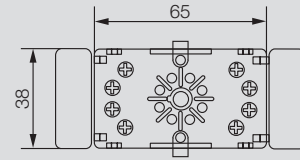
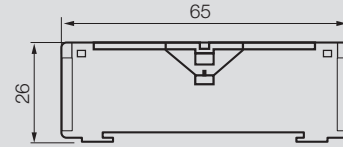

C

Ordering data

Description	Type	Qty	Order No.
Plug-in module with screw connections, 8-pole	SRD-I 2CO	10	8869360000
Plug-in module with screw connections, 11-pole	SRD-I 3CO	10	8869350000

Contact data	
Nominal current	10 A
Nominal voltage	400 V AC
Dielectric strength, coil/contacts	>2500 Veff
Ambient temperature	-20 °C ... + 80 °C
Ingress protection class (IEC 61810)	IP 20
Conductor cross-section / with wire end ferrule	2 x 2.5 mm ² / 2 x 1.5 mm ²
Terminal torque	0.5 / 0.7 Nm

Retaining clip (metal)

Ordering data	
Accessories	
Description	Type Order No.
Metal retaining clip, RRD	SRD-I CLIP M 8869370000

Relays - RIDERSERIES

RPW relay 2 CO contact AC/DC coil 3 CO contact AC/DC coil

- 6000 VA switching capacity
- Mechanical indicator
- with and without test button



Cap without lug, plug-in connections

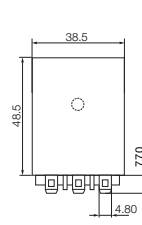

Cap with fixing lug, 6.3 mm Faston (4.8 mm possible)

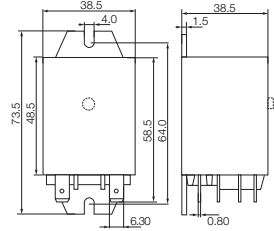

C

Circuit diagram

View of connections

2 changeover contacts

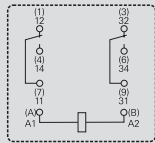

3 changeover contacts

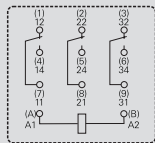

Output

max. switching voltage AC1	400 V
Continuous current	16 A
Contact base material	AgCdO
Mechanical endurance	20*10 ⁶ switching cycles
Response time / Drop-out time	15 ms / 10 ms

Rated data

Status indicator/Free wheel diode	mechanical/no
Ambient temperature (operational)	-45 °C...+70 °C
UL 94 flammability rating	V-0
Approvals	cURus; CE; VDE;

Insulation coordination (IEC 60664)

Rated voltage	400 V
Clearance and creepage distances for control/load side	≤ 6mm
Surge category	III
Pollution severity	3

Dimensions

Length x width x height	mm	38.5 / 38.5 / 48.5
-------------------------	----	--------------------

Note

Applications

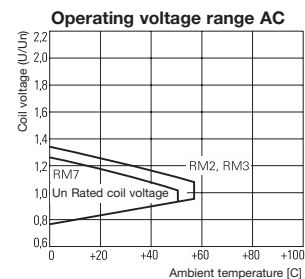
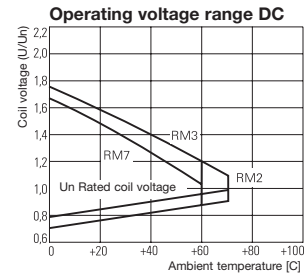
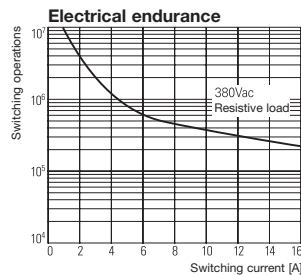
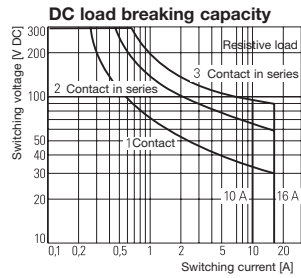

RPW relay
2 CO contact AC/DC coil
3 CO contact AC/DC coil

Type code		RPW				
Typ	RIDER PoWer					
Contacts	2 2 change-over contacts 7 3 change-over contacts					
Type of construction	0 Without test button 3 With test button					
Housing	2 Cap without lug, 4.8 mm Faston 5 Cap with lug, 6.3 mm Faston					
DC coil						
006		6 V DC				
012		12 V DC				
024		24 V DC				
048		48 V DC				
060		60 V DC				
110		110 V DC				
AC coil						
506		6 V AC				
512		12 V AC				
524		24 V AC				
548		48 V AC				
615		115 V AC				
730		230 V AC				

Ordering data

	24 V DC 2CO	24 V AC 2CO	230 V AC 2CO	
Input				
Rated voltage	24 V DC	24 V AC	230 V AC	
DC Response/dropout Volt	18 V / 2.4 V	19.2 V / 9.6 V	184 V / 92 V	
Power rating	1.2 W	2.3 VA	2.3 VA	
Rated current DC	50.5 mA	94.2 mA	10.1 mA	
Coil resistance	475 Ω ±10%	86 Ω ±10%	8300 Ω ±12%	

C

Ordering data Relay

		24 V DC 2CO	24 V AC 2CO	230 V AC 2CO	
without test button	Type	RPW202024	RPW202524	RPW202730	
AgCdO	Order No.	8690730000	on request	8690720000	
	Type				
	Order No.				
	Type				
	Order No.				

Note

--	--	--	--	--

Ordering data

	24 V DC 3CO	24 V AC 3CO	230 V AC 3CO	
Input				
Rated voltage	24 V DC	24 V AC	230 V AC	
DC Response/dropout Volt	18 V / 2.4 V	19.2 V / 9.6 V	184 V / 92 V	
Power rating	1.6 W	2.8 VA	2.8 VA	
Rated current DC	69.6 mA	109.2 mA	11.7 mA	
Coil resistance	345 Ω ±10%	80 Ω ±10%	7500 Ω ±10%	

Ordering data Relay

		24 V DC 3CO	24 V AC 3CO	230 V AC 3CO	
without test button	Type	RPW702024	RPW702524	RPW702730	
AgCdO	Order No.	8690760000	8690740000	8690750000	
	Type				
	Order No.				
	Type				
	Order No.				

Note

--	--	--	--	--

Relays - RIDERSERIES

Accessories for RPW
Plug-in module with screw connection



Dimensions in mm

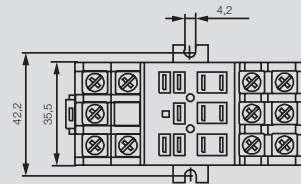
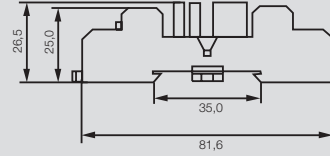

C

Ordering data

Description	Type	Qty	Order No.
Plug-in module with screw connections	SPW 3CO	25	8697680000
Contact data			
Nominal current	16 A		
Nominal voltage	250 V AC		
Dielectric strength, coil/contacts	>2500 Vms		
Ambient temperature	-40 °C ... +40 °C		
Terminal torque	0.8 Nm		
Max.	1.2 Nm		

Plug-in socket with PCB connections
for RCL relays

Ordering data

Description	
Plug-in socket with PCB connections, pinning 3.5 mm	
Plug-in socket with PCB connections, pinning 5 mm	
Accessory: metal retaining clip, 15.7 mm high	
Accessory: metal retaining clip, 25.5 mm high	
Technical data	
Nominal current	1-pole
	2-pole
Nominal voltage	
Ambient temperature	
Approvals	



Type	Qty	Order No.
SRC 1CO PCB	100	8690860000
SRC 2CO PCB	100	8690850000
SRC CLIP LM		8693810000
SRC CLIP HM		8692620000
Technical data		
Nominal current	12 A	
	2 x 12 A	
Nominal voltage	300 V AC	
Ambient temperature	-40 °C ... +80 °C	
Approvals		

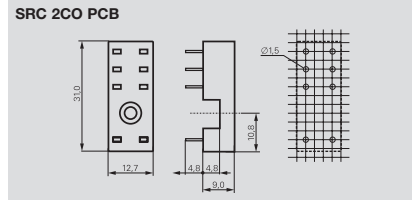
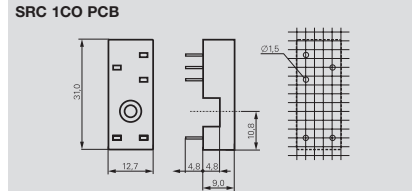

Plug-in socket with solder/PCB connections
for RCM relays

Ordering data

Description	
Plug-in socket with solder connections, 4-pole	
Plug-in socket with PCB connections, 2-pole	
Plug-in socket with PCB connections, 3-pole	
Plug-in socket with PCB connections, 4-pole	
Accessory: metal retaining clip, 29 mm high	
Technical data	
Nominal current	
Nominal voltage	
Ambient temperature	
Approvals	



Type	Qty	Order No.
SCM 4CO PCB	25	8697610000
SCM 2CO PCB	25	8697620000
SCM 3CO PCB	25	8697640000
SCM 4CO PCB	25	8697660000
SRM CLIP LM		8694400000
Technical data		
Nominal current	10 A	
Nominal voltage	250 V AC	
Ambient temperature	-40 °C ... +80 °C	
Approvals		

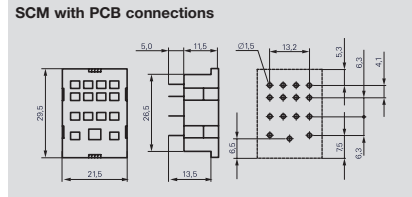
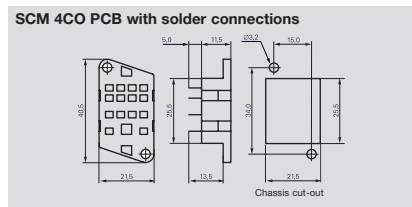

Plug-in socket with PCB connections
for RRD relays

Ordering data

Description	
Plug-in socket with solder and PCB connections	8-pole
Plug-in socket with solder and PCB connections	11-pole
Technical data	
Nominal current	
Nominal voltage	
Ambient temperature	



Type	Qty	Order No.
SRD 2CO PCB	25	8697750000
SRD 3CO PCB	25	8697730000
Technical data		
Nominal current	10 A	
Nominal voltage	250 V A-C	
Ambient temperature	-40 °C ... +70 °C	
Approvals		

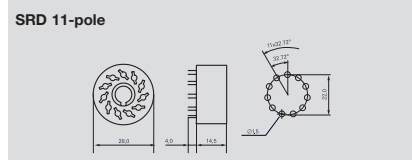
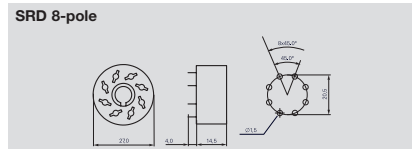

Plug-in socket with PCB connections
for RPW relays

Ordering data

Description	
Plug-in socket with PCB connections	
Accessory: metal retaining clip, RPW	
Technical data	
Approvals	



Type	Qty	Order No.
SPW 3CO PCB		8697710000
SPW CLIP M		8697780000
Technical data		
Approvals		

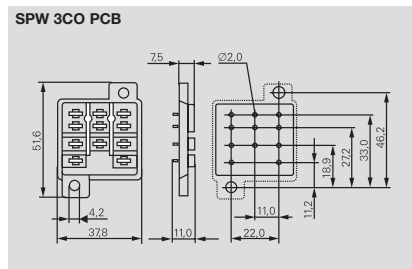

**1 NCC, 1 NOC
or 1 change-over contact**

RS 30

Screw connection

1 NOC
1 NCC



1 change-over contact



RS 30

Isolating plug with screw connection

1 NOC
1 NCC



1 change-over contact



Technical data

Input voltage 5 ... 60 V ± 10 %; 115 V/230 V + 5 % – 15 %
Nominal consumption – (W)
Nominal consumption – (VA)
Drop-out current of relay (at 20 °C)
Drop-out current of relay (at 20 °C)
Pick-up current
Output voltage max.
Continuous current

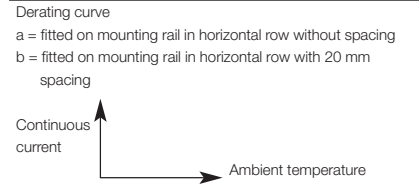

5 VTTL	12 V~	24 V~	24 V=	48 V~	48 V=	60 V~	115 V~	115 V=	230 V~ ²⁾	240 V~
0.45 W ¹⁾	0.45 W	0.45 W	0.45 W	0.45 W	0.45 W	0.45 W	–	0.82 W	–	–
–	–	–	0.7 VA	–	0.6 VA	–	0.8 VA	–	0.8 VA	1.2 VA
–	3 mA	3 mA	2.5 mA~	2 mA	2.5 mA~	1 mA~	–	2 mA~	–	0.5 mA~
–	–	–	3.5 mA~	–	4.5 mA~	–	1 mA~	–	1 mA~	1 mA~
–	–	12 mA	–	10 mA	–	–	6 mA	4.3 mA	–	–
250 V	250 V	250 V	250 V	250 V	250 V	250 V	250 V	250 V	250 V	250 V
5 A	6 A	6 A	6 A	6 A	5 A	5 A	5 A	5 A	3 A	3 A

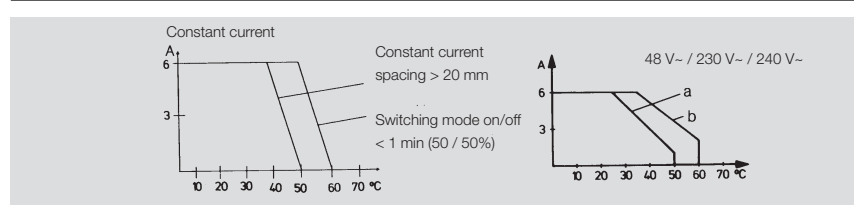

Making current
Making power under ohmic load
Min. switching power/switching current
Duration of bounce
Typical switching times
–, Pick-up delay
–, Drop-out delay
Max. switching frequency
Contact material
Service life, mechanical
–, 24 V-, 1A ohmic load
–, 230 V-, 3A, ohmic load
Storage temperature
Ambient temperature, fitted on mounting rail
–, in horizontal row without spacing
–, in horizontal row with > 20 mm spacing

8 A										
2000 VA / 100 W										
250 mW / 10 mA										
≤ 3 ms										
≤ 8 ms	≤ 8 ms	≤ 8 ms	≤ 8 ms	≤ 12 ms	≤ 13 ms	≤ 12 ms	≤ 9 ms	≤ 12 ms	≤ 10 ms	≤ 10 ms
≤ 7 ms	≤ 7 ms	≤ 7 ms	≤ 16 ms	≤ 11 ms	≤ 12 ms	≤ 11 ms	≤ 8 ms	≤ 11 ms	≤ 9 ms	≤ 9 ms
70 Hz	70 Hz	70 Hz	30 Hz	70 Hz	20 Hz	70 Hz	30 Hz	70 Hz	30 Hz	30 Hz
AgNi, gold-flashed										
> 10 ⁷ switching cycles										
> 5 x 10 ⁵ switching cycles										
> 7 x 10 ⁵ switching cycles										
–40 °C ... +60 °C										
–25 °C ... +40 °C										
–25 °C ... +50 °C										

Insulation coordination to EN 50178
Surge category
Pollution severity
Dimensions
Mounting width
Length (at 90° to mounting rail)
Height (with TS 32 / TS 35 x 7.5)

III
2
11.2 mm NOC / NCC, 25 mm change-over contact
70 mm (74 mm BL/SL version)
56 mm / 51.5 mm

1) Rated consumption of auxiliary voltage 24 V–
2) 230 V– on request

RS 30

Screw connection

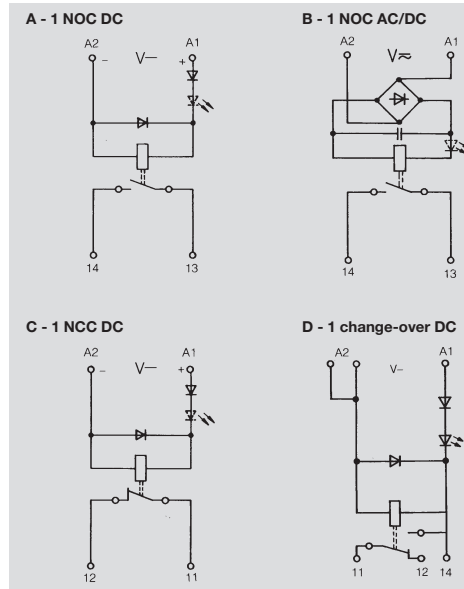

RS 30

Isolating plug with screw connection

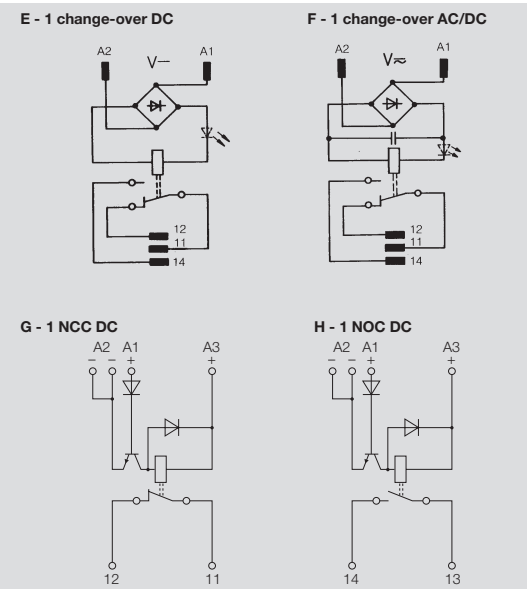

Digital signalling

C

Ordering data

Wiring diagram	
Input voltage	Function indicator
5 V-, TTL	without
12 V-	without LED red
24 V-	without LED green LED red
24 V=	without LED green LED red
48 V-	without LED green LED red
48 V=	without LED green
60 V-	without LED red
115 V-	without LED green LED red
115 V-	without LED green LED red
230 V-	without LED green LED red
240 V-	LED green LED red

A	B	C	D
NOC	NOC	NCC	change-over
1129421001		1129521001	
1101661001		1100961001	
1101611001		1100911001	1181511001
1101621001		1100921001	1181521001
	1101761001		
	1101711001		
	1101721001		
1101861001			
1101811001			
1101821001			
	1101911001		
1102061001			
1155161001			
1155111001		1155211001	
1155121001		1155221001	
	1102111001		
	1102121001		
	1102261001		
	1102211001		
	1102221001		
	1128511001		
	1128521001		

E	F	G	H
change-over	change-over	NCC	NOC
		1167660000	1167760000
	1129660000		
1100260000			
1100210000			
1100220000			
	1100360000		
1100410000			
1100420000			
	1100560000		
	1100620000		
	1100760000		
	1100860000		

Relays - RS-SERIES - RS 31

**1 change-over contact
AC/DC/UC coil**

- For high switching capacity
- Suitable for switching inductive loads



C

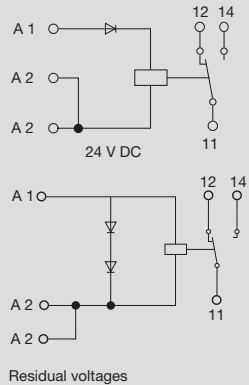

Output		
max. switching voltage AC1/Continuous current	250 V/16 A	
min. switching power	1 W	
Response time / Drop-out time	9ms/10ms	
Contact base material	AgCdO	
Mechanical endurance	3*10 ⁷ switching cycles	
max. switching frequency at rated load	0.1 Hz	
Rated data		
Status indicator/Free wheel diode	LED red/Yes	
Reverse pol. prot.	available	
Ambient temperature (operational)	-25 °C...+40 °C	
Storage temperature	-40 °C...+60 °C	
Humidity	40°C/93% RH, no condensation	
Approvals	CE;	
Insulation coordination (EN 50178)		
Standards	EN 50178	
Rated voltage	250 V	
Impulse withstand voltage	6 kV	
Clearance and creepage distances for control/load side	3 mm	
Surge category	III	
Pollution severity	2	
Protective separation to VDE 0106 part 101	no	
Dimensions	Screw connection	Tension clamp connection
Clamping range (rating- / min. / max.)	mm ²	2.5 / 0.5 / 4
Length x width x height	mm	70 / 25 / 53.5
Note		

Applications

Derating curve

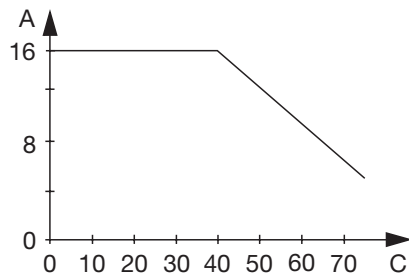

**1 change-over contact
AC/DC/UC coil**

C

Ordering data	24VDC 1CO	48VDC 1CO	115VAC 1CO	230VAC 1CO
Input				
Rated voltage	24 V DC ±10%	48 V DC ±10 %	115 V AC +5 %/ -15 %	230 V AC + 5 / - 15%
Rated current AC			8 mA	4.5mA
Rated current DC	40 mA	20 mA		
Power rating	1W	1W	1 VA	1VA
AC Response/dropout Volt			98 V	195 V
DC Response/dropout Volt	21.5V	43 V		
AC pickup/dropout current			-/1.5mA	-/2.2mA
DC pickup/dropout current	-/11.5mA	-/13.5mA		
Ordering data				
Relay with socket				
Screw connection Type	RS 31 24VDC LD LP 1U	RS 31 48VDC LD 1U LP	RS 31 115VAC LD LP 1U	RS 31 230VAC LD LP 1U
Order No.	1128361001	1150761001	1150461001	1128461001
Tension spring connection Type				
Order No.				
Ordering data				
Spare relay (pluggable)				
Type				
Order No.				
Note				
Ordering data				
Input				
Rated voltage				
Rated current AC				
Rated current DC				
Power rating				
AC Response/dropout Volt				
DC Response/dropout Volt				
AC pickup/dropout current				
DC pickup/dropout current				
Ordering data				
Relay with socket				
Screw connection Type				
Order No.				
Tension spring connection Type				
Order No.				
Ordering data				
Spare relay (pluggable)				
Type				
Order No.				
Note				

**2 change-over contacts
DC coil**

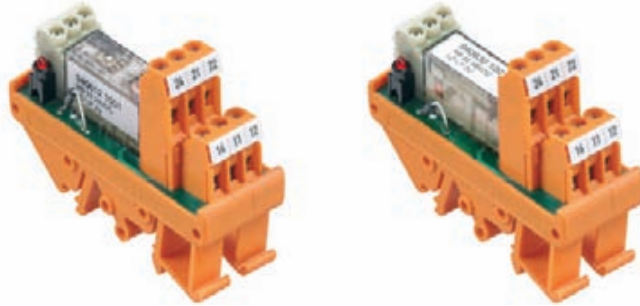

C

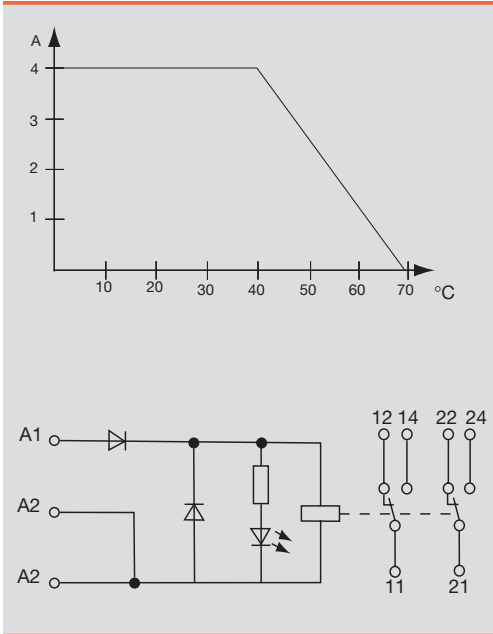

Output	
max. switching voltage AC1/Continuous current	250 V/4 A
min. switching power	10 V / 10 mA
Response time / Drop-out time	13ms/10ms
Contact base material	AgNi 90/10
Mechanical endurance	>30*10 ⁶ switching cycles
max. switching frequency at rated load	0.1 Hz
Rated data	
Status indicator/Free wheel diode	LED red/no
Reverse pol. prot	available
Ambient temperature (operational)	-25 °C...+40 °C
Storage temperature	-40 °C...+60 °C
Humidity	40°C/93% RH, no condensation
Approvals	CE;
Insulation coordination (EN 50178)	
Standards	EN 50178
Rated voltage	250 V
Impulse withstand voltage	4 kV
Clearance and creepage distances for control/load side	3 mm
Surge category	III
Pollution severity	2
Protective separation to VDE 0106 part 101	no
Dimensions	
Clamping range (rating- / min. / max.)	mm ² 2.5 / 0.5 / 4
Length x width x height	mm 70 / 25 / 63.5
Note	

Ordering data	12VDC 2CO	24VDC 2CO	48VDC 2CO	
Input				
Rated voltage	12 V DC ±10 %	24 V DC ±10%	48 V DC ±10 %	
Rated current AC				
Rated current DC	50 mA	25 mA	12 mA	
Power rating	0.6W	0.6W	0.6W	
AC Response/dropout Volt				
DC Response/dropout Volt	11 V	21.5V	43 V	
AC pickup/dropout current				
DC pickup/dropout current	-/9.5mA	-/5 mA	-/2 mA	
Ordering data Complete module				
Screw connection Type	RS 32 12VDC LD LP 2U	RS 32 24VDC LD LP 2U	RS 32 48VDC LD LP 2U	
Order No.	9406021001	9406121001	9406321001	
Tension clamp connection Type				
Order No.				
Ordering data Spare relay, pluggable				
Type				
Order No.				
Note				

2 change over contacts
UC coil

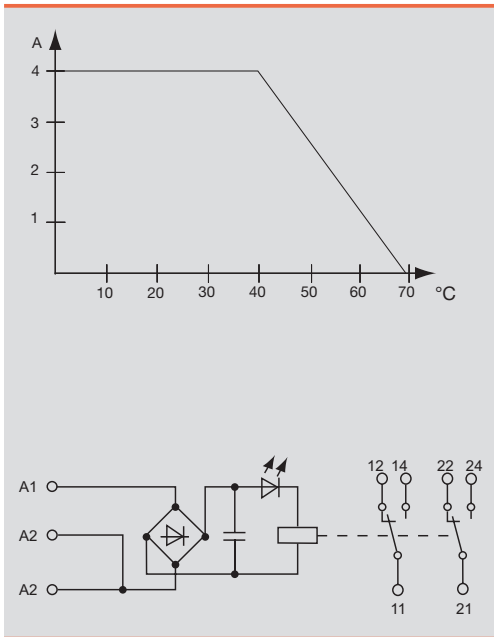
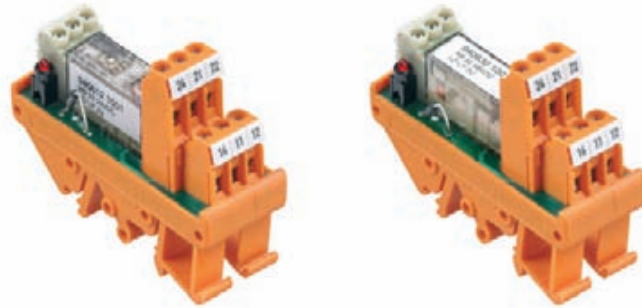

Output	
max. switching voltage AC1/Continuous current	250 V/4 A
min. switching power	5 V / 10 mA
Response time / Drop-out time	13ms/10ms
Contact base material	AgNi 90/10
Mechanical endurance	>30*10 ⁶ switching cycles
max. switching frequency at rated load	0.1 Hz
Rated data	
Status indicator/Free wheel diode	LED red/no
Reverse pol. prot	available
Ambient temperature (operational)	-25 °C...+40 °C
Storage temperature	-40 °C...+60 °C
Humidity	40°C/93% RH, no condensation
Approvals	CE;
Insulation coordination (EN 50178)	
Standards	EN 50178
Rated voltage	250 V
Impulse withstand voltage	4 kV
Clearance and creepage distances for control/load side	3 mm
Surge category	III
Pollution severity	2
Protective separation to VDE 0106 part 101	no
Dimensions	
Clamping range (rating- / min. / max.)	mm ² 2.5 / 0.5 / 4
Length x width x height	mm 70 / 25 / 63.5
Note	

Ordering data

Input	
Rated voltage	24 V UC ±10 %
Rated current AC	28 mA
Rated current DC	18 mA
Power rating	0.6W // 0.9VA
AC Response/dropout Volt	
DC Response/dropout Volt	21.5V
AC pickup/dropout current	-/2.5mA
DC pickup/dropout current	-/4.5mA

24VUC 2CO	
Rated voltage	24 V UC ±10 %
Rated current AC	28 mA
Rated current DC	18 mA
Power rating	0.6W // 0.9VA
AC Response/dropout Volt	
DC Response/dropout Volt	21.5V
AC pickup/dropout current	-/2.5mA
DC pickup/dropout current	-/4.5mA

48VUC 2CO	
Rated voltage	48 V UC ±10 %
Rated current AC	18mAac
Rated current DC	12 mA
Power rating	0.6W // 0.9VA
AC Response/dropout Volt	
DC Response/dropout Volt	43 V
AC pickup/dropout current	-/4.5mA
DC pickup/dropout current	-/2 mA

115VUC 2CO	
Rated voltage	115 V UC + 5 / - 15%
Rated current AC	5mA
Rated current DC	5 mA
Power rating	0.5W // 0.6VA
AC Response/dropout Volt	
DC Response/dropout Volt	98 V
AC pickup/dropout current	-/1.5mA
DC pickup/dropout current	-/1 mA

230VUC 2CO	
Rated voltage	230 V UC + 5 / - 15%
Rated current AC	4.3mA
Rated current DC	4.3mA
Power rating	1W //1VA
AC Response/dropout Volt	
DC Response/dropout Volt	195 V
AC pickup/dropout current	-/2 mA
DC pickup/dropout current	-/1.2mA

Ordering data
Complete module

Screw connection	Type	RS 32 24VUC LD LP 2U
	Order No.	9406221001
Tension clamp connection	Type	
	Order No.	

Screw connection	Type	RS 32 24VUC LD LP 2U
	Order No.	9406221001
Tension clamp connection	Type	
	Order No.	

Screw connection	Type	RS 32 48VUC LD LP 2U
	Order No.	9406421001
Tension clamp connection	Type	
	Order No.	

Screw connection	Type	RS 32 115VUC LD LP 2U
	Order No.	9406621001
Tension clamp connection	Type	
	Order No.	

Screw connection	Type	RS 32 230VUC LD LP 2U
	Order No.	9406721001
Tension clamp connection	Type	
	Order No.	

Ordering data
Spare relay, pluggable

	Type	
	Order No.	

	Type	
	Order No.	

	Type	
	Order No.	

	Type	
	Order No.	

	Type	
	Order No.	

Note	
-------------	--

Note	
-------------	--

Note	
-------------	--

Note	
-------------	--

Note	
-------------	--

**2 change over contacts
multiple voltage input**

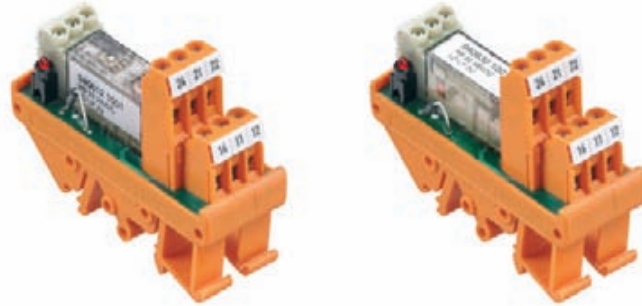

C

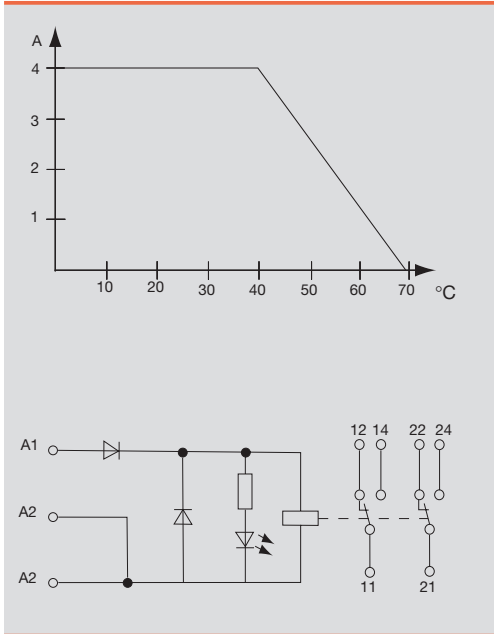

Output	
max. switching voltage AC1/Continuous current	250 V/4 A
min. switching power	10 V / 10 mA
Response time / Drop-out time	13ms/10ms
Contact base material	AgNi 90/10
Mechanical endurance	>30*10 ⁸ switching cycles
max. switching frequency at rated load	0.1 Hz
Rated data	
Status indicator/Free wheel diode	LED red/no
Reverse pol. prot	available
Ambient temperature (operational)	-25 °C...+40 °C
Storage temperature	-40 °C...+60 °C
Humidity	40°C/93% RH, no condensation
Approvals	CE;
Insulation coordination (EN 50178)	
Standards	EN 50178
Rated voltage	250 V
Impulse withstand voltage	4 kV
Clearance and creepage distances for control/load side	3 mm
Surge category	III
Pollution severity	2
Protective separation to VDE 0106 part 101	no
Dimensions	
Clamping range (rating- / min. / max.)	mm ² 2.5 / 0.5 / 4
Length x width x height	mm 70 / 25 / 63.5
Note	

Ordering data

	24-48VUC 2CO	115-230VUC 2CO		
Input				
Rated voltage	24 V // 48 V UC ±10 %	115 // 230 V UC + 5 / - 15%		
Rated current AC	28 mA / 22 mA	5.6mA/5.3mA		
Rated current DC	18 mA / 20 mA	5.4mA/5mA		
Power rating	0.6W // 0.9VA	1W // 1VA		
AC Response/dropout Volt				
DC Response/dropout Volt	21.5V/43V	98 V/ 195 V		
AC pickup/dropout current	-/3mA // -/4.5mA	-/1.5mA // -/2mA		
DC pickup/dropout current	-/5mA // -/2mA	-/1mA // -/1.2mA		

Ordering data Complete module				
Screw connection	Type	RS 32 24-48VUC LD LP 2U	RS 32 115-230VUC LD 2U	
	Order No.	1122661001	1122761001	
Tension clamp connection	Type			
	Order No.			
Ordering data Spare relay, pluggable				
	Type			
	Order No.			
Note				

2 changeover contacts
Positive-action contacts

- DC coil
- Relay with 2 positive-action changeover contacts to EN 50205
- 2-pole safety relay with 2 changeover contacts *)
- Mounts on TS32/35

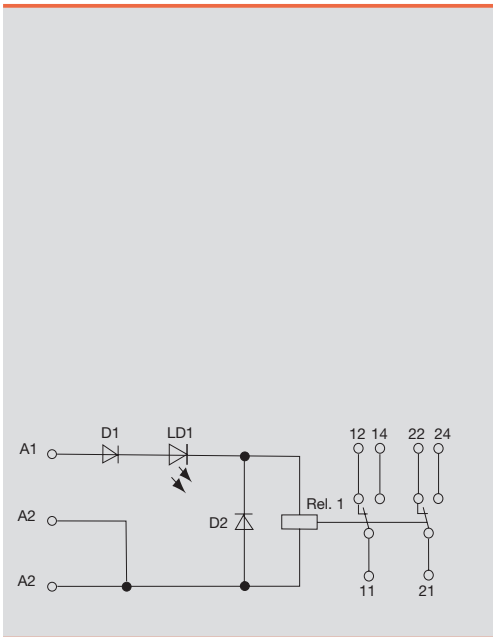

Output			
max. switching voltage AC1/Continuous current	250 V/4 A		
min. switching power	5 V / 10 mA		
Response time / Drop-out time	13ms/10ms		
Contact base material	AgNi 90/10		
Mechanical endurance	>20*10 ⁹ switching cycles		
max. switching frequency at rated load	0.1 Hz		
Rated data			
Status indicator/Free wheel diode	LED red/no		
Reverse pol. prot	Yes		
Ambient temperature (operational)	-25 °C...+40 °C		
Storage temperature	-40 °C...+85 °C		
Humidity	40°C/93% RH, no condensation		
Approvals	CE;		
Insulation coordination (EN 50178)			
Standards	EN 50178		
Rated voltage	300 V		
Impulse withstand voltage	4 kV		
Clearance and creepage distances for control/load side	4 mm		
Surge category	III		
Pollution severity	2		
Protective separation to VDE 0106 part 101	no		
Dimensions			
Clamping range (rating- / min. / max.)	mm ²	Screw connection	Tension clamp connection
		2.5 / 0.5 / 4	
Length x width x height	mm	70 / 25 / 63.5	
Note		*) According to EN50205, only 1 NO / 1 NC is permitted for safety circuits	

Ordering data

Input	
Rated voltage	24 V DC ±10%
Rated current AC	
Rated current DC	21 mA
Power rating	0.5 W
AC Response/dropout Volt	
DC Response/dropout Volt	16 V // 10 V
AC pickup/dropout current	
DC pickup/dropout current	12.5 mA // 7 mA

24 V DC 2CO	

Ordering data Complete module

Screw connection	Type	RS32 24 VDC SAFETY
	Order No.	8872160000
Tension clamp connection	Type	
	Order No.	

Ordering data Spare relay, pluggable

	Type	
	Order No.	

Note	

Relays - RS-SERIES - with RSM multiple interface

4-/8-/16-way, ea. with 1 COC

- Red LEDs , other colours on request
- Mounting feet can also be mounted turned through an angle of 180°

RSM 4 R / RSM 4 RS

4 relays
soldered or plug-in

RSM 8 R / RSM 8 RS

8 relays
soldered or plug-in

RSM 16 R / RSM 16 RS

16 relays
soldered or plug-in

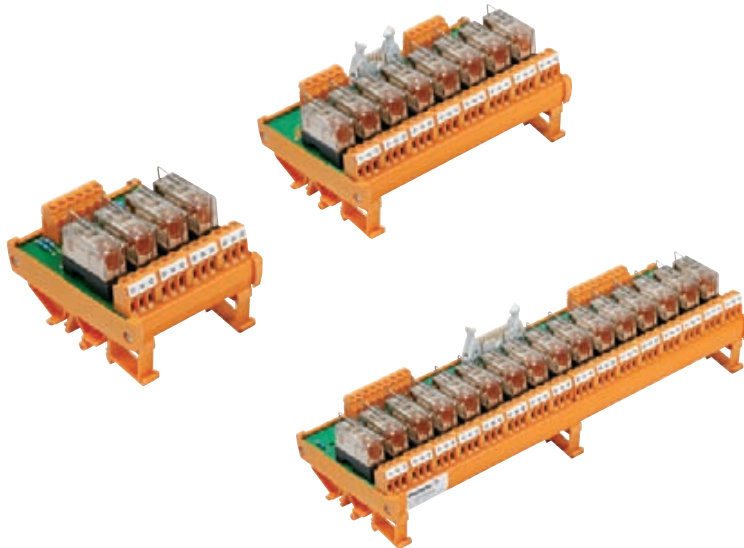

Technical data

Rated data	
Input voltage	
Nominal consumption DC	soldered relay
	plug-in relay
Nominal consumption AC	soldered relay
	plug-in relay
Pick-up current DC	soldered relay
	plug-in relay
Pick-up current AC	soldered relay
	plug-in relay

Drop-out current of relay (at 20 °C)	
Output voltage max.	
Continuous current	

Derating curve
a = fitted on mounting rail in horizontal row without spacing
b = fitted on mounting rail in horizontal row with 20 mm spacing



24 V DC	24 V AC/DC	48 V DC	115 V AC/DC	230 V AC
0.45 W	-	-	-	-
0.75 W	0.45 W	0.75 W	-	-
-	-	-	-	-
-	0.7 VA	-	0.6 VA	1.2 VA
12 mA	-	-	-	-
23 mA	12 mA	14 mA	5 mA	-
-	-	-	-	-
-	16.5 mA	-	6 mA	4 mA
2 mA		1.5 mA		1 mA
250 V	250 V	250 V	250 V	250 V
6 A	6 A	6 A	6 A	3 A

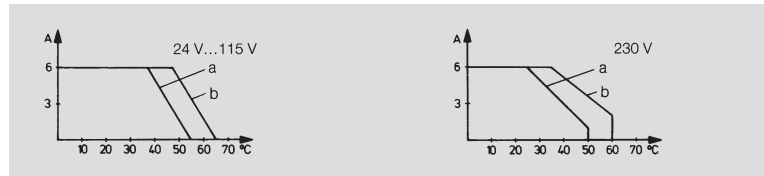

Typical making times	
	Pick-up delay (AC / DC)
	Drop-out delay (AC / DC)

≤ 8 ms	≤ 10 ms / 10 ms	≤ 12 ms	≤ 8 ms / 10 ms	≤ 10 ms
≤ 7 ms	≤ 15 ms / 20 ms	≤ 11 ms	≤ 5 ms / 8 ms	≤ 10 ms

Duration of bounce	
Making current	
Making power under ohmic load	
Min. switching power / switching current	
Contact material	
Service life	mechanical
	24 V DC, 1A, ohmic load
	230 V AC, 3A, ohmic load
Storage temperature	
Ambient temperature	

≤ 3 ms
8 A
2000 VA
250 mW/10 mA
AgNi 90/10, AgNi0,15, gold-flashed
> 30 x 10 ⁶ switching cycles
> 5 x 10 ⁶ switching cycles
> 7 x 10 ⁶ switching cycles
-40 °C ... +60 °C
-25 °C ... +50 °C

Insulation coordination to EN 50178

Surge category	III
Pollution severity	2

Dimensions

Conductor cross-section (screw connection)	0.5 ... 2.5 mm ²
--	-----------------------------

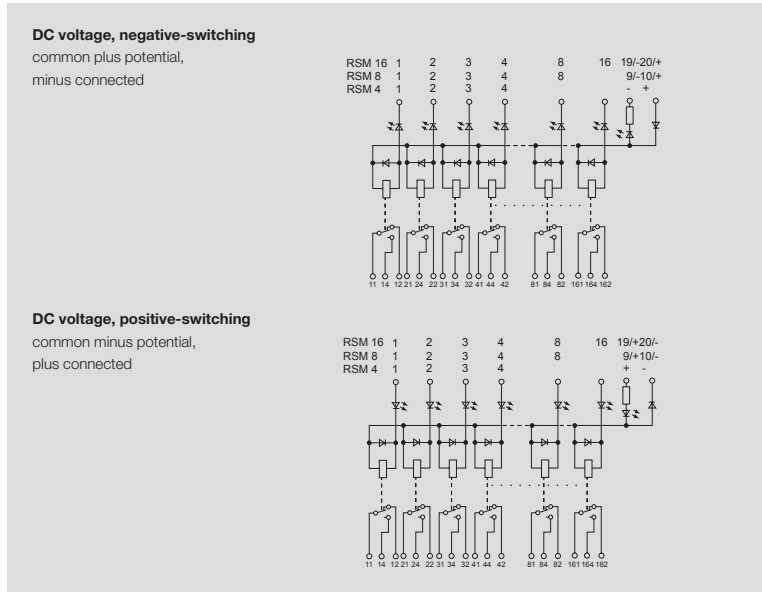
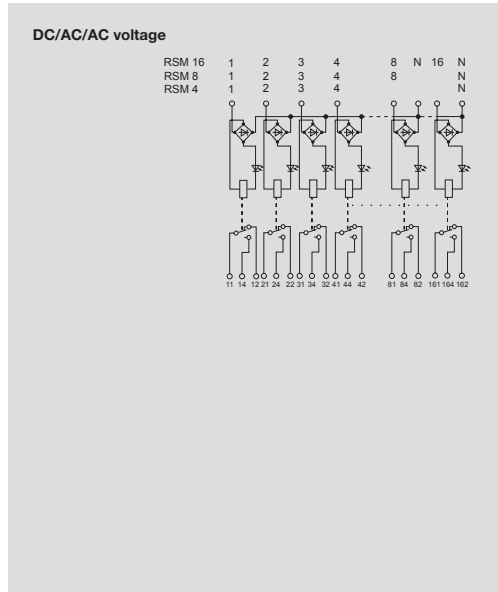

Ordering data

Connection system	
Input	Screw connection
Output	Screw connection

- Plug-in relay
- Screw connection and multiple plug to IEC 603-1/DIN 41651
- Relay soldered
- Multiple plug to IEC 603-1/DIN 41651

		4 relays RSM 4 R/RS (B = 75 mm)	8 relays RSM 8 R/RS (B = 145 mm)	16 relays RSM 16 R/RS (B = 285 mm)
Input voltage	24 V DC, switching plus	Relay pluggable 1113361001 ¹⁾	1113561001 ¹⁾	1113761001 ¹⁾
		Relay soldered 1112361001	1107761001	1107861001
	24 V DC, switching minus	Relay pluggable 1113461001 ¹⁾	1113661001 ¹⁾	1113861001 ¹⁾
	24 V AC/DC	Relay pluggable 1173461001	1173561001	1173661001
	48 V DC, switching plus	Relay pluggable	1114161001	
	115 V AC/DC	Relay pluggable 1114561001	1114661001	1114761001
	230 V AC	Relay pluggable 1114861001	1114961001	1115061001

¹⁾ approved by Germanisch Lloyd

Spare relays (pluggable)

For RSM ... R/RS, 24 V
For RSM ... R/RS, 48 V
For RSM ... R/RS, 115 V and 230 V

Input voltage	Contact material	Remarks	Order no.
24 V DC	AgNi 90/10	RT 314024 with clip	8630780000
	AgNi 90/10	RT 314024 without clip	4058480000
48 V DC	AgNi 90/10	RT 314048 without clip	4058740000
115 V DC	AgNi 90/10	RT 314110 with clip	8630770000
	AgNi 90/10	RT 314110 without clip	4058500000

Relays - WAVESERIES

1 change-over contact
AC/DC/UC coil



C

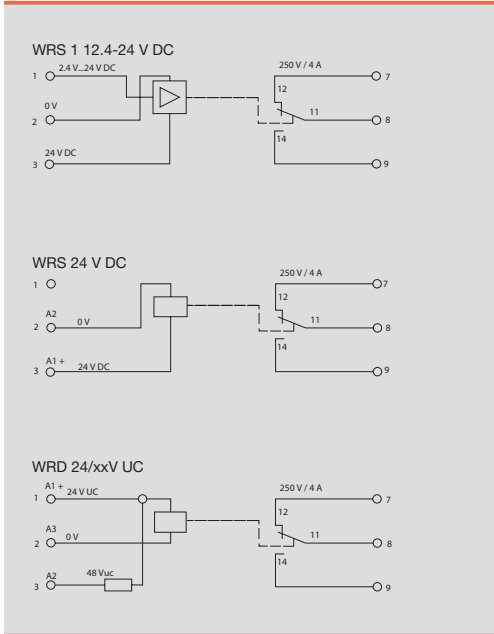

Output			
max. switching voltage AC1/Continuous current	250 V/5 A		
min. switching power	100 mA / 5 V DC		
Response time / Drop-out time	7ms/6ms		
Contact base material	Gold alloy		
Mechanical endurance	20*10 ⁶ switching cycles		
max. switching frequency at rated load	0.1 Hz		
Rated data			
Status indicator/Free wheel diode	green LED/Yes		
Reverse pol. prot	available		
Ambient temperature (operational)	-25 °C...+50 °C		
Storage temperature	-40 °C...+60 °C		
Humidity	40°C/93% RH, no condensation		
Approvals	CSA;cURus;CE;		
Insulation coordination (EN 50178)			
Standards	EN 50178		
Rated voltage	300 V		
Impulse withstand voltage	6 kV (1.2/50 µs)		
Clearance and creepage distances for control/load side	≥ 5.5 mm		
Surge category	III		
Pollution severity	2		
Protective separation to VDE 0106 part 101	Yes		
Dimensions			
Clamping range (rating- / min. / max.)	mm ² 1.5 / 0.5 / 2.5	Screw connection	Tension clamp connection
Length x width x height	mm 72 / 22.5 / 92.4		
Note			

Applications

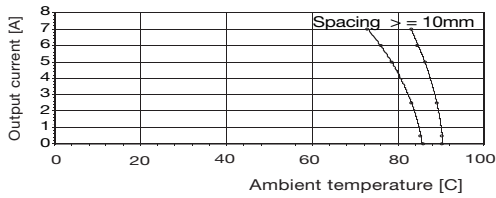

**1 change-over contact
AC/DC/UC coil**

C

Ordering data	2.4-24 V DC 1CO	24 V DC 1CO	24 / 48 V UC 1CO	24 V UC/230 V AC 1CO
Input				
Rated voltage	2,4...24 V DC ±10 %	24 V DC ±10%	24 V // 48 V UC ±10 %	24 V UC // 230 V AC, ±10 %
Rated current AC			approx. 14 mA	approx. 15 mA
Rated current DC	4.6 mA	9 mA	14 mA	14 mA (24 V DC)
Power rating	200 mW	220 mW	0.35 VA / 0.5 VA	0,34 VA / 0,32 W // 3,5 VA
AC Response/dropout Volt			16 V/9,5 V // 29 V/15 V	13 V /9 V //115 V /66 V
DC Response/dropout Volt	1.9 V	16 V / 7.5 V	16 V/9,5 V // 29 V/15 V	13 V /9 V (24 V DC)
AC pickup/dropout current			9 mA/4,5 mA // 8,3 mA/4,1 mA	7.5 mA/4.7 mA // 7.4 mA/4.3 mA
DC pickup/dropout current	3.88 mA	5.7 mA / 2.2 mA	9 mA/4,5 mA // 8,3 mA/4,1 mA	7.5 mA/4.7 mA
Ordering data Relay with socket				
Screw connection Type	WRS1 2.4-24VDC 1U	WRS1 24VDC 1U	WRS1 24/48VUC 1U	WRS1 24VUC/230VAC 1U
Order No.	8275320000	8275350000	8286280000	8418230000
Tension spring connection Type				
Order No.				
Ordering data Spare relay (pluggable)				
Type				
Order No.				
Note				
Ordering data				
Input				
Rated voltage				
Rated current AC				
Rated current DC				
Power rating				
AC Response/dropout Volt				
DC Response/dropout Volt				
AC pickup/dropout current				
DC pickup/dropout current				
Ordering data Relay with socket				
Screw connection Type				
Order No.				
Tension spring connection Type				
Order No.				
Ordering data Spare relay (pluggable)				
Type				
Order No.				
Note				

Relays - WAVESERIES

2 NO contacts
AC/DC/UC coil



C

Derating curve

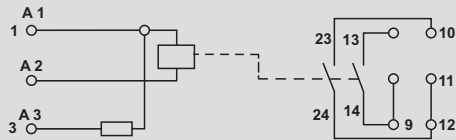
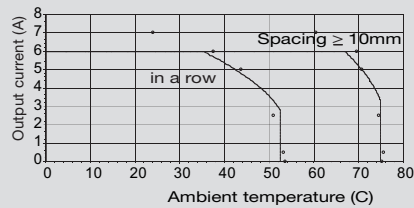

Output	
max. switching voltage AC1/Continuous current	250 V/5 A
min. switching power	100 mA / 5 V DC
Response time / Drop-out time	5ms/6ms
Contact base material	AgSnO2
Mechanical endurance	50*10 ⁶ switching cycles
max. switching frequency at rated load	0.1 Hz
Rated data	
Status indicator/Free wheel diode	green LED/Yes
Reverse pol. prot	available
Ambient temperature (operational)	-25 °C...+50 °C
Storage temperature	-40 °C...+60 °C
Humidity	40°C/93% RH, no condensation
Approvals	CSA;cURus;CE;
Insulation coordination (EN 50178)	
Standards	EN 50178
Rated voltage	300 V
Impulse withstand voltage	6 kV (1.2/50 µs)
Clearance and creepage distances for control/load side	≥ 8 mm
Surge category	III
Pollution severity	2
Protective separation to VDE 0106 part 101	Yes
Dimensions	
Clamping range (rating- / min. / max.)	mm ² 1.5 / 0.5 / 2.5
Length x width x height	mm 92.4 / 22.5 / 112.4
Note	

Ordering data

	12 / 24 V DC 2NO	24 / 48 V UC 2NO	115 V UC/230 V AC 2NO	
Input				
Rated voltage	12 V DC // 24 V DC, ±10 %	24 V // 48 V UC ±10 %	115 V UC // 230 V AC, ±10 %	
Rated current AC		approx. 11 mA	approx. 10 mA	
Rated current DC	approx. 20 mA	approx. 8.5 mA	9 mA (115 V DC)	
Power rating	0,24 W // 0,5 W	0,17 W/0,21 VA // 0,4 W/0,48 VA	1 VA / 0,9 W // 2,5 VA	
AC Response/dropout Volt		13,5 V /9 V // 24 V/16 V	58 V /22 V // 110 V/40 V	
DC Response/dropout Volt	7.5 V /3.5 V // 14.5 V/6.1 V	16 V /7.8 V // 28 V/12 V	54 V /20 V (115 V DC)	
AC pickup/dropout current		4.4 mA/2.7 mA // 4.3 mA/2.6 mA	4.8 mA/1.7 mA V // 5 mA/2 mA	
DC pickup/dropout current	10 mA/4.2 mA // 10 mA/4 mA	4.3 mA/1.6 mA // 4.4 mA/1.6 mA	4 mA / 2 mA	
Ordering data Complete module				
Screw connection Type	WRS2 12/24VDC 2A	WRS2 24/48VUC 2A	WRS2 115VUC/230VAC 2A	
Order No.	8418240000	8418250000	8418260000	
Tension clamp connection Type				
Order No.				
Ordering data Spare relay, pluggable				
Type				
Order No.				
Note				

1 NC contact / 1 NO contact
DC/UC coil



Derating curve

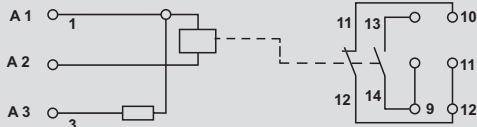
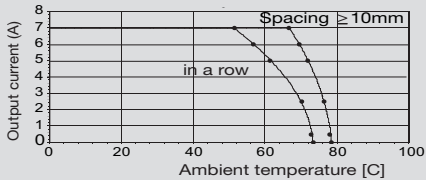

Output	
max. switching voltage AC1/Continuous current	250 V/5 A
min. switching power	100 mA / 5 V
Response time / Drop-out time	7ms/5ms
Contact base material	AgSnO2
Mechanical endurance	50*10 ⁶ switching cycles
max. switching frequency at rated load	0.1 Hz
Rated data	
Status indicator/Free wheel diode	green LED/Yes
Reverse pol. prot	available
Ambient temperature (operational)	-25 °C...+50 °C
Storage temperature	-40 °C...+60 °C
Humidity	40°C/93% RH, no condensation
Approvals	CSA;cURus;CE;
Insulation coordination (EN 50178)	
Standards	EN 50178
Rated voltage	300 V
Impulse withstand voltage	6 kV (1.2/50 µs)
Clearance and creepage distances for control/load side	≥ 8 mm
Surge category	III
Pollution severity	2
Protective separation to VDE 0106 part 101	Yes

Dimensions	Screw connection	Tension clamp connection
Clamping range (rating- / min. / max.)	mm ² 1.5 / 0.5 / 2.5	
Length x width x height	mm	92.4 / 22.5 / 112.4

Note

Ordering data

Input	
Rated voltage	
Rated current AC	
Rated current DC	
Power rating	
AC Response/dropout Volt	
DC Response/dropout Volt	
AC pickup/dropout current	
DC pickup/dropout current	

12/24 V DC 1NO/1NC	
Rated voltage	12 V DC // 24 V DC, ±10 %
Rated current AC	
Rated current DC	approx. 20 mA
Power rating	0,24 W // 0,5 W
AC Response/dropout Volt	
DC Response/dropout Volt	7.5 V /3.5 V // 14.5 V/6.1 V
AC pickup/dropout current	
DC pickup/dropout current	10 mA/4.2 mA // 10 mA/4 mA

24/48 V UC 1NO/1NC	
Rated voltage	24 V // 48 V UC ±10 %
Rated current AC	approx. 11 mA
Rated current DC	approx. 8.5 mA
Power rating	0,17 W/0,21 VA // 0,4 W/0,48 VA
AC Response/dropout Volt	13.5 V /9 V // 24 V/16 V
DC Response/dropout Volt	13.5 V /9 V // 24 V/16 V
AC pickup/dropout current	4.4 mA/2.7 mA // 4.3 mA/1.6 mA
DC pickup/dropout current	4.3 mA/1.6 mA // 4.4 mA/1.6 mA

115 V UC/230 V AC	
Rated voltage	115 V UC // 230 V AC, ±10 %
Rated current AC	approx. 10 mA
Rated current DC	9 mA (115 V DC)
Power rating	1 VA / 0,9 W // 2,5 VA
AC Response/dropout Volt	58 V /22 V // 110 V/40 V
DC Response/dropout Volt	54 V /20 V (115 V DC)
AC pickup/dropout current	4.8 mA/1.7 mA // 5 mA/2 mA
DC pickup/dropout current	4 mA/1.6 mA

Ordering data
Complete module

Screw connection	Type	
	Order No.	
Tension clamp connection	Type	
	Order No.	

Screw connection	Type	WRS2 12/24VDC 1A1R
	Order No.	8418270000
Tension clamp connection	Type	
	Order No.	

Screw connection	Type	WRS2 24/48VUC 1A1R
	Order No.	8418280000
Tension clamp connection	Type	
	Order No.	

Screw connection	Type	WRS2 115VUC/230VAC 1A1R
	Order No.	8418290000
Tension clamp connection	Type	
	Order No.	

Ordering data
Spare relay, pluggable

	Type	
	Order No.	

	Type	
	Order No.	

	Type	
	Order No.	

	Type	
	Order No.	

Note

Relays - WAVESERIES

**2 change-over contacts
AC/DC/UC coil**



C

Derating curve

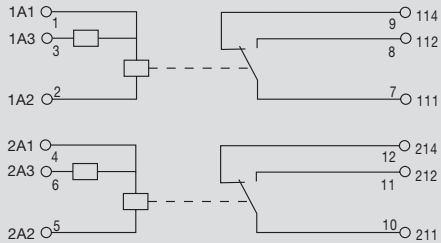
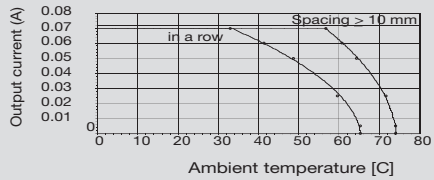

Output		
max. switching voltage AC1/Continuous current	250 V/5 A	
min. switching power	100 mA / 5 V DC	
Response time / Drop-out time	6ms/10ms	
Contact base material	Gold alloy	
Mechanical endurance	20*10 ⁶ switching cycles	
max. switching frequency at rated load	0.1 Hz	
Rated data		
Status indicator/Free wheel diode	green LED/Yes	
Reverse pol. prot	available	
Ambient temperature (operational)	-25 °C...+50 °C	
Storage temperature	-40 °C...+60 °C	
Humidity	40°C/93% RH, no condensation	
Approvals	CSA;cURus;CE;	
Insulation coordination (EN 50178)		
Standards	EN 50178	
Rated voltage	300 V	
Impulse withstand voltage	6 kV (1.2/50 µs)	
Clearance and creepage distances for control/load side	≥ 5.5 mm	
Surge category	III	
Pollution severity	2	
Protective separation to VDE 0106 part 101	Yes	
Dimensions		
Clamping range (rating- / min. / max.)	mm ²	Screw connection 1.5 / 0.5 / 2.5
Length x width x height	mm	Tension clamp connection 92.4 / 22.5 / 112.4
Note		

Ordering data

	12/24 V DC 2CO	24/48 V UC 2CO	24 V UC/230 V AC 2CO	
Input				
Rated voltage	12 V DC // 24 V DC, ±10 %	24 V // 48 V UC ±10 %	24 V UC // 230 V AC, ±10 %	
Rated current AC		approx. 15 mA	approx. 15 mA	
Rated current DC	approx. 23 mA	14 mA	14 mA (24 V DC)	
Power rating	0,26 W // 0,53 W	0,35 VA(W) // 0,7 VA(W)	0,35 W // 3,45 VA	
AC Response/dropout Volt			13 V/9 V // 115 V/66 V	
DC Response/dropout Volt	8,5 V /3 V // 15 V/4,8 V	16 V /9,5 V // 29 V /15 V	13 V / 9 V (24 V DC)	
AC pickup/dropout current		9 mA/4,5 mA // 8,3 mA/4,1 mA	7,5 mA/4,7 mA // 7,4 mA/4,3 mA	
DC pickup/dropout current	15,2 mA/5,7 mA//15,3 mA/5,6 mA	9 mA/4,5 mA // 8,3 mA/4,1 mA	7,5 mA // 4,7 mA	
Ordering data Complete module				
Screw connection Type	WRS2 12/24VDC 2U	WRS2 24/48VUC 2U	WRS2 24VUC/230VAC 2U	
Order No.	8418300000	8418310000	8418320000	
Tension clamp connection Type				
Order No.				
Ordering data Spare relay, pluggable				
Type				
Order No.				
Note				

Housing forms for optos

C

DK-SERIES



All components of the DKO mini-coupler are extremely slim: the use of the latest surface-mounted devices (SMD) allows us to keep the width to just 6 mm. The mini-couplers support a wide range of applications relating to the coupling of digital sensor/actuator signals with automation devices and the process field. DKO optos are designed to pick up and standardise signals of different voltages from the field.

MICROSERIES



The **MICROSERIES** range integrates the product features of the RSS power relay into the world of terminals. The user therefore benefits from the special features of terminals: he retains a free choice of connection system, plug-in cross-connection, standardised marking solutions as well as the space saving advantage typical of relays!

WAVESERIES



Innovative electronic components require a housing or enclosure that reflects their specific functions. They must allow adjustment and operation functions and support electro-mechanical requirements such as heat dissipation or electromagnetic compatibility. A compact design saves space in the control cabinet and reduces assembly costs. Ergonomic design is increasingly important for top-quality opto interfaces.

MCZ-SERIES



The MCZ enclosure is only 6 mm wide and one of the narrowest of its kind. Its outstanding technical features include:

- Tension clamp connection to reduce assembly costs
- Integrated cross-connection in input and output minimizes wiring workload.

PLUGSERIES



The **PLUGSERIES** offers you proven product features from the world of connection systems combined with the performance of the Weidmüller RCL power relay. The plug-in cross-connection ZQV enables quick and easy bridging of input and output potentials. Besides a free choice of the connection system, PLUGSERIES products are unique as a result of the Wemid housing material.

JACKPAC®



JACKPAC® integrates basic functions of signal processing such as amplification, isolation and conversion of signals, but also provides protective functions thanks to packaging to IP68 standard that is compatible with field wiring conditions. This allows you to both realise decentralised wiring concepts without having to accept a compromise solution and to optimally use digital input-output components from the IP6X world.

MICROOPTO



The MICROOPTO range of products provide the user with the tried and tested characteristics of terminal blocks. Pluggable cross-connections and harmonised marking solutions packaged in a minimum design width. Best performance within a small footprint.

- 6.1 mm design width
- Pluggable standard cross-connection ZQV 4N
- Housing material made of WEMID (higher thermal stability in comparison with polyamide)

Power Solid State Relays



For many industrial applications, the switching performance of contactors is no longer sufficient for switching loads reliably over long periods. For this reason, heating elements in plastics machinery, to take one example, are synchronized in order to control the heat output. Electro-mechanical components quickly reach the limits of their capacity in this regard. The switching noises from contactors are often a source of disturbance and distraction. This is where Power Solid-State Relays, with their noise-free, wear-free switching function, are right for the job.

Control circuit

The input circuits (control circuit)

Most industrial application cannot be connected directly to an opto, generally requiring voltage regulation by means of series-connected resistances or capacitors.

To obtain exact-as-possible switching points a *Schmitt Trigger* can be used to assign the control signals an unambiguous status (0 - 1) when moving from high to low or low to high, which is then passed on to the opto.

Depending on the design, all Weidmüller opto modules and solid-state relays are equipped with suitable protective devices (varistors, diodes) and filters to protect against interference pulses from the control circuit.

DC input:

An additional reverse-polarity protection diode guarantees protection against the opto being destroyed if the control voltage is incorrectly wired. The switching status of the control circuit is signalled by a status indicator.

AC/DC input:

A rectifier with smoothing capacitor is connected in series for AC control voltages. Reverse polarity protection for DC current is not necessary. The following construction corresponds to a DC circuit.

Due to the smoothing capacitor the switching frequency of AC control signals is fundamentally less than half the mains frequency. A higher switching frequency would result in the control signal being constantly switched through in rhythm with the mains frequency.

The advantage of being able to choose between an AC or a DC current input contrasts with the disadvantage that the smoothing capacitor also restricts the switching frequency of the DC control signal.

AC input:

The circuit diagram corresponds in principle with an AC/DC circuit. Instead of series resistors it is possible to use capacitors to regulate the voltage in a purely AC operation. In contrast to resistors there is no power loss with capacitors and as a result no heat that needs to be dissipated.

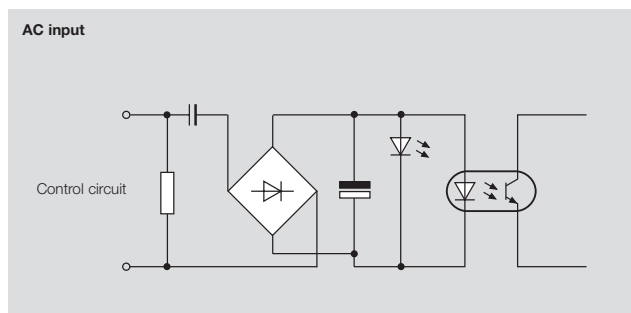
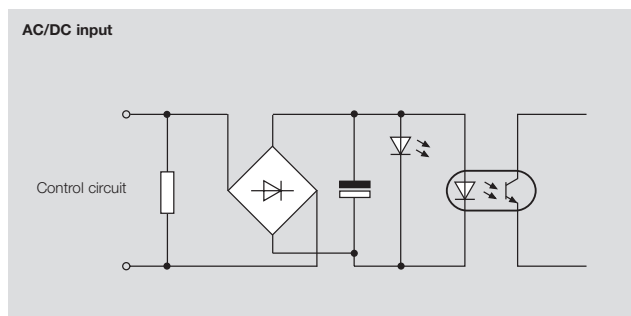
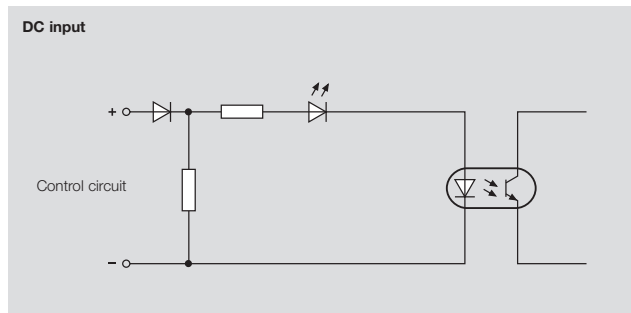
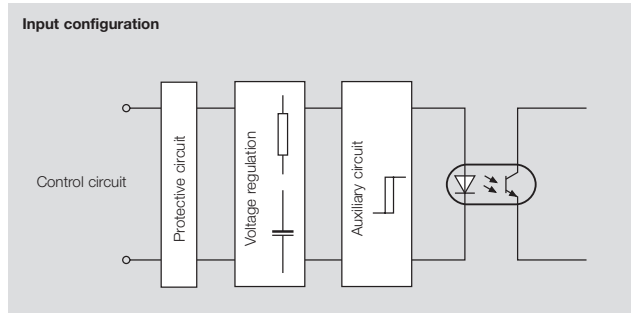

Load circuit

The output circuit (load circuit)

As a rule, an operating voltage range is stated for the rated switching voltage of opto modules and solid state relays (for example 5 ... 48 V DC); it is not permitted to exceed or fall below this value.

The same applies to continuous current. Exceeding this value to often can result in premature wear-out and destruction of the optos semiconductor.

As a direct correlation exists between the current and ambient temperature a derating curve is provided for all opto modules and solid-state relays.

Overvoltages are shunted by protective devices such as diodes or varistors.

To prevent damage caused by current spikes (for example starting or off pulses) some modules are equipped with a *power boost* which is capable of carrying higher levels of current than the maximum stated for a short period of time.

It is possible to connect AC or DC loads subject to the output circuit having corresponding amplifier semiconductors.

DC output:

With a 2-pole DC output the connection terminals are to be considered in the same manner as with a conventional switch. All that is required is that care is taken to observe the predetermined polarity.

With a 3-pole DC connection an auxiliary voltage assists the output circuit to control the amplifying transistor more precisely. Several applications also require this auxiliary voltage for short-circuit protection in the interface or protective circuitry.

AC output:

To activate AC switching and control devices a semiconductor is connected on the load side of the opto component to switch the AC voltage (TRIAC or thyristor).

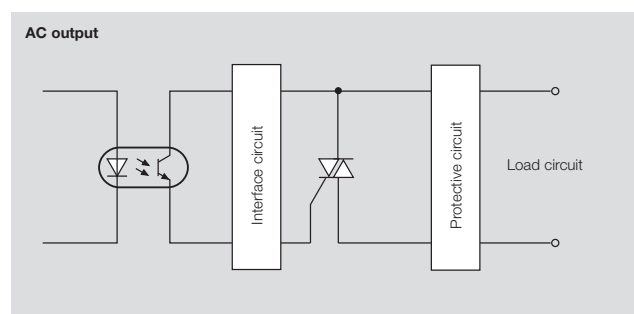
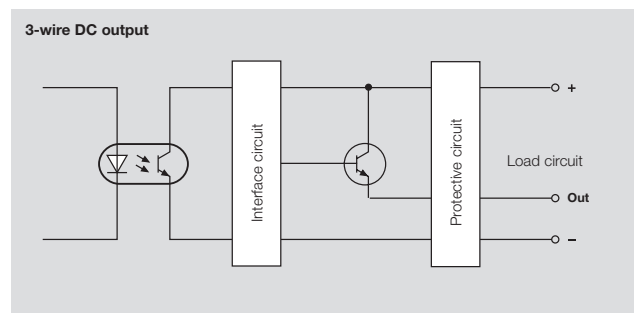
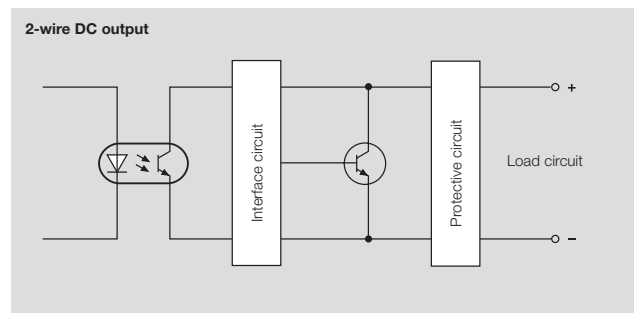
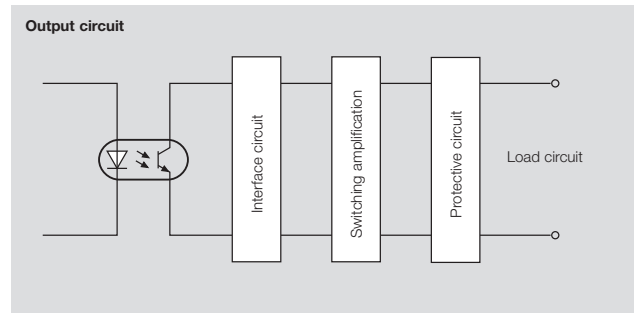

C

Switching amplification

The phototransistor of the opto has a low current and voltage rating. As a consequence, an additional semiconductor element is accessed for larger output loads that is capable of switching the corresponding rated switching voltages and rated switching currents.

C

Bipolar Transistor (DC)

Used for low currents (0.5 A).

The bipolar transistor has short response times, which makes high switching frequencies possible as a result.

MOSFET (DC)

Used for high load currents (up to 10 A).

The low contact resistance of the MOSFET create only very small leakage currents ($< 10 \mu\text{A}$) with low power loss.

TRIAC (AC)

A TRIAC combines the functional principle of antiparallel connected thyristors in a single component.

The mode of function of a thyristor is comparable with that of a one-way diode. Therefore, an opposing parallel circuit configuration consisting of two thyristors is used for AC currents.

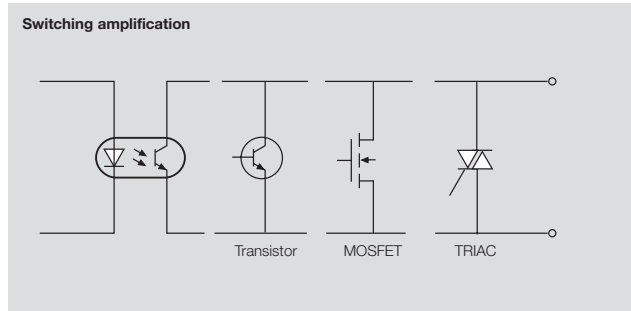

Switching diverse loads

The different types of loads resulting from the possible applications (resistive, inductive, capacitive loads) represent a particular challenge for the load circuit arrangements of opto modules and solid-state relays. With reference to the planned application, one should always be aware of what effects the loads will have on the modules and how the corresponding protective devices have to be designed.

Generally speaking, it must be ensured that the power loss at the amplifier semiconductor does not exceed the permitted limit for any length of time. This would lead to overheating and finally to the destruction of the component.

Switching resistive loads

Due to the fact that in resistive loads the amperage in the load circuit and the voltage across the amplifier semiconductor are inversely proportional to one another these do not generally pose a problem. It is sufficient to adhere to the maximum current and voltage ratings of the modules.

Switching glow lamps represents a special case. It is possible that when being switched on that overcurrents 10 to 20 times the operating current can occur due to the low cold resistance. Therefore, the components must be designed to cope with these possible overloads situations which correspond to the effect of capacitive loads.

Switching capacitive loads

Capacitive loads occur if there is a capacitor in the load circuit. The effect is similar to to a short-circuit at the point of activation and results in a high inrush current. If this current is not limited it can lead to the destruction of the amplifier semiconductor.

Switching inductive loads

Problems can arise with inductive loads when they are being switched off, in particular when coils are used in the load circuit. The flow of current in the coil builds up a magnetic field that suddenly collapses and creates a high induction voltage. This voltage spike has to be short-circuited via a diode connected in parallel (free-wheeling diode). However, the time required leads to delayed release.

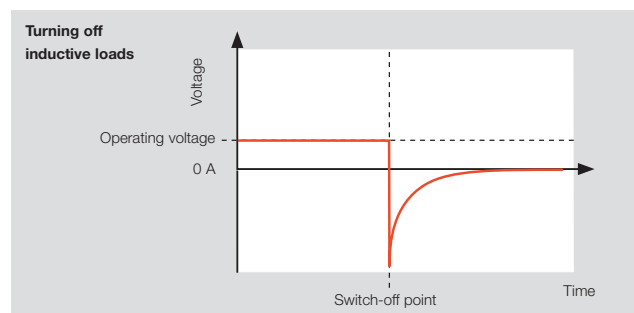
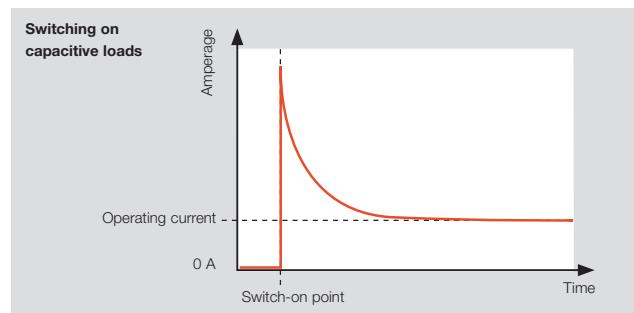

Protective measures

The construction of the opto enables fast and sensitive switching, however, the component is also more prone to interference. For this reason, all Weidmüller opto modules and solid-state relays are equipped with a variety of measures to protect against overloading and interference pulses.

C

Free-wheeling diodes (DC)

Free-wheeling diodes are used primarily to protect against overvoltages, which occur through self-induction when switching off inductive DC loads (electric motors, relay coils).

Voltage spikes are limited to the equivalent value of the diode forward voltage and excess voltage is discharged via the diode. However, this leads to a delay in the voltage drop and as such also delays the switching operation.

Zener diode / suppressor diode (DC)

These function as normal diodes in the forward conducting direction. In the blocking direction they become low resistant at a certain voltage (breakdown voltage).

High levels of overvoltages can lead to the destruction of the zener diode / suppressor diode.

Varistor (AC/DC)

The functional principle of the varistor is also based on a breakdown voltage, but with faster reaction times. This allows higher levels of energy to be shunted, however, these lead to the component aging. This in turn reduces the breakdown voltage over time and increases the leakage current.

RC-element (AC)

The RC element compensates voltage spikes by means of a capacitor. Due to the charging and discharging characteristics interference pulses are filtered out when the voltage is rising and not first when overload is reached.

For this reason, RC elements are used to protect against interference pulses and exclude faulty switching operations.

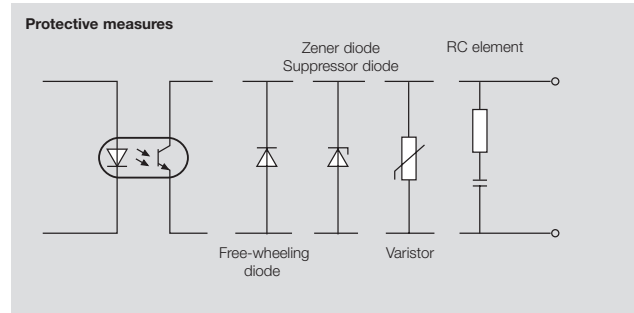

Optos - DK-SERIES

Mini-coupler DKO

- Coupling of digital sensor/actuator signals between PLC and process
- Inexpensive solution for adapting level and potential
- Low input power
- Screw connection system
- 6 mm width
- For mounting on TS 35

5 V DC



5 V TTL

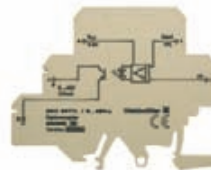

12 V DC 10 kHz



C

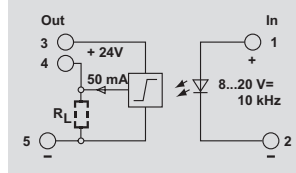
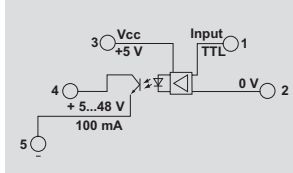
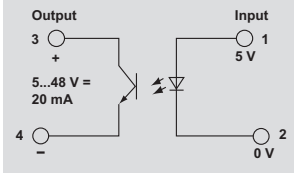

Technical data

Control side

Rated voltage
Power rating
max. input frequency
Nominal auxiliary voltage
Status indicator

5 V DC $\pm 5\%$
50 mW
300 Hz
no
LED green

5 V TTL
50 μ W
3 kHz
5 V
LED green

8...20 V DC
max. 130 mW
max. 10 kHz
no
LED green

Load side

Nominal switching voltage
Nominal switching current
Voltage drop at max. load
Switch-on delay/Switch-off delay
Short-circuit-proof/Protective circuit

5...48 V DC
20 mA
 $\leq 1,6$ V
 $\leq 15 \mu$ s/ $\leq 70 \mu$ s
no/diode

5...48 V DC
100 mA
 $\leq 1,6$ V
approx. 27 μ s/approx. 35 μ s
no/diode

24 V DC $\pm 10\%$
50 mA
 ≤ 1 V
1 μ s/2,5 μ s
no/diode

General data

Ambient temperature (operational)
Storage temperature
Approvals

-25 °C...+40 °C
-40 °C...+85 °C
CE;

-25 °C...+40 °C
-40 °C...+85 °C
CE;

-25 °C...+40 °C
-40 °C...+85 °C
CE;

Insulation coordination (EN 50 178)

Standards
Rated voltage
Rated impulse withstand voltage
Clearance and creepage distances for control side - load side
Surge category
Pollution severity

EN 50178
150 V
4.0 kV
 ≥ 4 mm

EN 50178
300 V
6.0 kV
 ≥ 5.5 mm

EN 50178
300 V
6.0 kV
 ≥ 5.5 mm

Dimensions

Clamping range (rating- / min. / max.) mm²
Length x width x height mm

Screw connection

4 / 0.5 / 4
65 x 6 x 57

Screw connection

4 / 0.5 / 4
77 x 6 x 62

Screw connection

4 / 0.5 / 4
65 x 12 x 57

Note

Ordering data

Connection system

Screw connection

Type	(Qty.=1)	Order No.
DKO 35 5VDC		8018630000

Type	(Qty.=1)	Order No.
DKO DK5 5VTTL		8228650000

Type	(Qty.=1)	Order No.
DKO 35 12VDC 10KHZ		8184030000

Note

Input at bottom

Input at bottom

Input at bottom

Accessories

Note

End plate
AP DKT4 0687560000

End plate
AP DK 5 PA BE: 4036780000

End plate
AP DKT 4: 0687560000

Mini-coupler DKO

- Coupling of digital sensor/actuator signals between PLC and process
- Inexpensive solution for adapting level and potential
- Low input power
- Screw connection system
- 6 mm width
- For mounting on TS 35

24 V UC

24 V DC 3 kHz

24 V DC 3 kHz

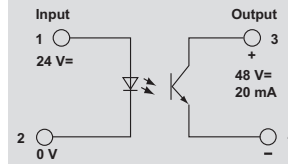
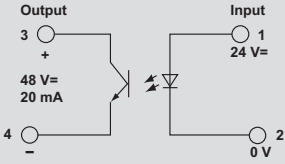
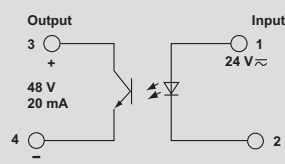
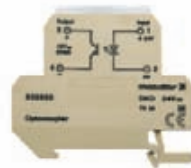

Technical data

Control side

Rated voltage
Power rating
max. input frequency
Nominal auxiliary voltage
Status indicator

24 V UC ±10 %
280 mVA / 230 mW
10 Hz at DC
no
LED green

24 V DC ±10%
max. 360 mW
3 kHz
no
LED green

24 V DC ±10%
max. 360 mW
3 kHz
no
LED green

Load side

Nominal switching voltage
Nominal switching current
Voltage drop at max. load
Switch-on delay/Switch-off delay
Short-circuit-proof/Protective circuit

5...48 V DC
20 mA
≤ 1 V
≤ 15 ms bei DC/≤ 25 ms bei DC
no/diode

5...48 V DC
20 mA
≤ 900 mV
approx. 50 µs/approx. 80 µs
no/diode

5...48 V DC
20 mA
≤ 900 mV
approx. 50 µs/approx. 80 µs
no/diode

General data

Ambient temperature (operational)
Storage temperature
Approvals

-25 °C...+40 °C
-40 °C...+85 °C
CE;

-25 °C...+40 °C
-40 °C...+85 °C
CE;

-25 °C...+40 °C
-40 °C...+85 °C
CE;

Insulation coordination (EN 50 178)

Standards
Rated voltage
Rated impulse withstand voltage
Clearance and creepage distances for control side - load side
Surge category
Pollution severity

EN 50178
300 V
4.0 kV
≥ 4 mm
III
2

EN 50178
300 V
4.0 kV
≥ 4 mm
III
2

EN 50178
300 V
4.0 kV
≥ 4 mm
III
2

Dimensions

Clamping range (rating- / min. / max.) mm²
Length x width x height mm

Screw connection

4 / 0.5 / 4
65 x 6 x 57

Screw connection

4 / 0.5 / 4
65 x 6 x 57

Screw connection

4 / 0.5 / 4
65 x 6 x 57

Note

Ordering data

Connection system

Screw connection

Type	(Qty.=1)	Order No.
DKO 35 24VUC		8008150000

Type	(Qty.=1)	Order No.
DKO 35 24VDC 3KHZ E:U		8028300000

Type	(Qty.=1)	Order No.
DKO 35 24VDC 3KHZ E:O		8215640000

Note

Input at bottom

Input at bottom

Input at top

Accessories

Note

End plate
AP DKT4 0687560000

End plate
AP DKT4 0687560000

End plate
AP DKT4 0687560000



Optos - DK-SERIES

Mini-coupler DKO

- Coupling of digital sensor/actuator signals between PLC and process
- Inexpensive solution for adapting level and potential
- Low input power
- Screw connection system
- 6 mm width
- For mounting on TS 35

24 V DC 3 kHz



24 V DC 100 Hz

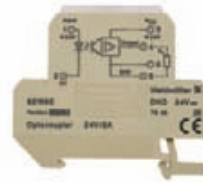

24 V DC 200 Hz



C

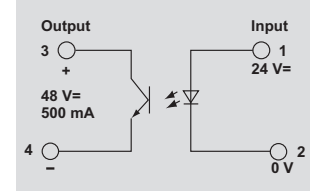
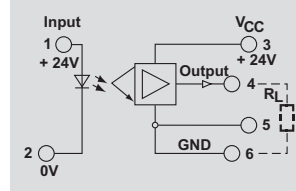
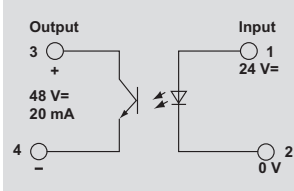

Technical data

Control side

Rated voltage
Power rating
max. input frequency
Nominal auxiliary voltage
Status indicator

24 V DC $\pm 10\%$
max. 204 mW
3 kHz
no
LED green

24 V DC $\pm 10\%$
max. 290 mW
100 Hz
no
LED green

24 V DC $\pm 10\%$
145 mW
200 Hz
no
LED green

Load side

Nominal switching voltage
Nominal switching current
Voltage drop at max. load
Switch-on delay/Switch-off delay
Short-circuit-proof/Protective circuit

5...48 V DC
20 mA
 ≤ 900 mV
approx. 50 μ s/approx. 80 μ s
no/diode

24 V DC $\pm 10\%$
2 A
2 ms/7 ms
yes/varistor

5...48 V DC
500 mA
 ≤ 800 mV
approx. 40 μ s/approx. 65 μ s
no/diode

General data

Ambient temperature (operational)
Storage temperature
Approvals

-25 °C...+40 °C
-40 °C...+85 °C
CE;

-25 °C...+40 °C
-40 °C...+85 °C
CE;

-25 °C...+40 °C
-40 °C...+85 °C
CE;

Insulation coordination (EN 50 178)

Standards
Rated voltage
Rated impulse withstand voltage
Clearance and creepage distances for control side - load side
Surge category
Pollution severity

EN 50178
300 V
4.0 kV
 ≥ 4 mm
III
2

EN 50178
300 V
4.0 kV
 ≥ 3 mm
III
2

EN 50178
300 V
4.0 kV
 ≥ 4 mm
III
2

Dimensions

Clamping range (rating- / min. / max.) mm²
Length x width x height mm

Screw connection

4 / 0.5 / 4
65 x 6 x 57

Screw connection

4 / 0.5 / 4
65 x 12 x 57

Screw connection

4 / 0.5 / 4
65 x 6 x 57

Note

Ordering data

Connection system

Screw connection

Type	(Qty.=1)	Order No.
DKO 35 24VDC 3KHZ E:U		8248790000

Type	(Qty.=1)	Order No.
DKO 35 24VDC E:U		8181990000

Type	(Qty.=1)	Order No.
DKO 35 24VDC E:U		8019590000

Note

Input at bottom

Input at bottom

Input at bottom

Accessories

Note

End plate
AP DKT4 0687560000

End plate
AP DKT4 0687560000

End plate
AP DKT4 0687560000

Mini-coupler DKO

- Coupling of digital sensor/actuator signals between PLC and process
- Inexpensive solution for adapting level and potential
- Low input power
- Screw connection system
- 6 mm width
- For mounting on TS 35

24 V DC 200 Hz



24 V DC 50 kHz

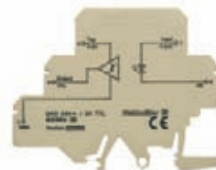

24 V UC

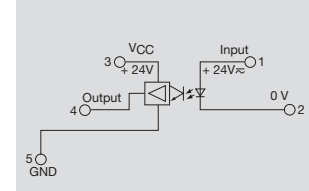
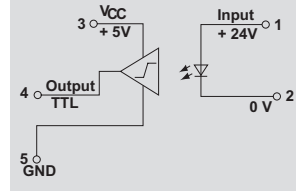
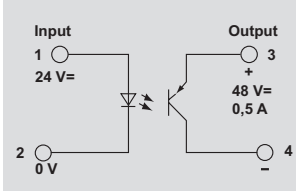

Technical data

Control side

Rated voltage
Power rating
max. input frequency
Nominal auxiliary voltage
Status indicator

24 V DC ±10%
max. 145 mW
200 Hz
no
LED green

24 V DC ±20 %
max. 112 mW
50 kHz
no
LED green

24 V DC ±20 %
max.: 220 mVA / 195 mW
≤ 10 Hz
no
LED *

Load side

Nominal switching voltage
Nominal switching current
Voltage drop at max. load
Switch-on delay/Switch-off delay
Short-circuit-proof/Protective circuit

5...48 Vdc
500 mA
≤ 800 mV
approx. 40 µs/approx. 65 µs
no/diode

5 V TTL
8 mA, fan out = 20 LS-TTL

1 µs/2.5 µs
no/diode

24 V DC ±20%
2 A

2 ms/7 ms
yes/

General data

Ambient temperature (operational)
Storage temperature
Approvals

-25 °C...+40 °C
-40 °C...+85 °C
CE;

-25 °C...+40 °C
-25 °C...+85 °C
CE;

-25 °C...+50 °C
-40 °C...+85 °C
CE;

Insulation coordination (EN 50 178)

Standards
Rated voltage
Rated impulse withstand voltage
Clearance and creepage distances for control side - load side
Surge category
Pollution severity

EN 50178
300 V
4.0 kV
≥ 4 mm
III
2

EN 50178
300 V
4.0 kV
≥ 5.5 mm
III
2

EN 50178
300 V
6.0 kV
≥ 5.5 mm
III
2

Dimensions

Clamping range (rating- / min. / max.) mm²
Length x width x height mm

Screw connection

4 / 0.5 / 4
65 x 6 x 57

Screw connection

4 / 0.5 / 4
77 x 6 x 62

Screw connection

4 / 0.5 / 4
77 x 6 x 62

* Status indicator: green = OK, yellow = partial short circuit, blinking red = short circuit

Note

Ordering data

Connection system
Screw connection

Type (Qty.=1) Order No.
DKO 35 24VDC E:O 8215630000

Type (Qty.=1) Order No.
DKO DK5 24VDC 50KHZ 8228640000

Type (Qty.=1) Order No.
DKO DK5 24VUC 8228630000

Note

Input at top

Input at top

Input at bottom

Accessories

Note

End plate
AP DKT4 0687560000

End plate
AP DK 5 PA BE: 4036780000

End plate
AP DK 5 PA BE: 4036780000

Optos - DK-SERIES

Mini-coupler DKO

- Coupling of digital sensor/actuator signals between PLC and process
- Inexpensive solution for adapting level and potential
- Low input power
- Screw connection system
- 6 mm width
- For mounting on TS 35

48 V UC



115 V UC



230 V UC



C

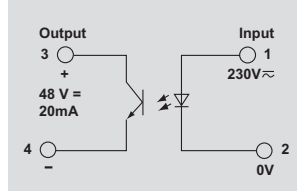
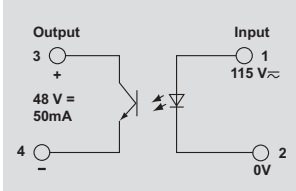
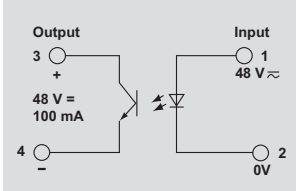

Technical data

Control side

Rated voltage
Power rating
max. input frequency
Nominal auxiliary voltage
Status indicator

48 V UC ±20 %
max.: 155 mVA / 135 mV
3 kHz
no
LED green

115 V UC +5 %/-15 %
390 mVA / 350 mW
AC: 5 Hz / DC: 20 Hz
no
LED green

230 V UC +5 %/-15 %
395 mVA / 370 mW
AC: 5 Hz / DC: 20 Hz
no
LED green

Load side

Nominal switching voltage
Nominal switching current
Voltage drop at max. load
Switch-on delay/Switch-off delay
Short-circuit-proof/Protective circuit

5...48 V DC
100 mA
≤ 1,5 V
5 ms/15 ms
no/diode

5...48 V DC
50 mA
≤ 1,6 V
17.4 ms/27.4 ms
yes/diode

5...48 V DC
20 mA
≤ 1,6 V
20 ms/20 ms
no/diode

General data

Ambient temperature (operational)
Storage temperature
Approvals

-25 °C...+50 °C
-40 °C...+85 °C
CE;

-25 °C...+40 °C
-40 °C...+85 °C
CE;

-25 °C...+50 °C
-40 °C...+85 °C
CE;

Insulation coordination (EN 50 178)

Standards
Rated voltage
Rated impulse withstand voltage
Clearance and creepage distances for control side - load side
Surge category
Pollution severity

EN 50178
300 V
4.0 kV
≥ 4 mm

EN 50178
300 V
6.0 kV
≥ 5.5 mm

EN 50178
300 V
6.0 kV
≥ 5.5 mm

Dimensions

Clamping range (rating- / min. / max.) mm²
Length x width x height mm

Screw connection

4 / 0.5 / 4
65 x 6 x 57

Screw connection

4 / 0.5 / 4
65 x 6 x 57

Screw connection

4 / 0.5 / 4
65 x 6 x 57

Note

Ordering data

Connection system

Screw connection

Type	(Qty.=1)	Order No.
DKO 35 48VUC		8025910000

Type	(Qty.=1)	Order No.
DKO 35 115VUC		8077860000

Type	(Qty.=1)	Order No.
DKO 35 230VUC		8008160000

Note

Input below

Input at bottom

Input at bottom

Accessories

Note

End plate
AP DK 4: 0687560000

End plate
AP DKT 4: 0687560000

End plate
AP DKT 4: 0687560000

MiniConditioner MCZ O

- Universal interface between control and sensor/actuator
- Direct switching of load currents up to 2 A DC
- Tension clamp connection system
- Plug-in cross-connection
- Width 6mm

24 V UC



24 V UC / 24 V 2 A

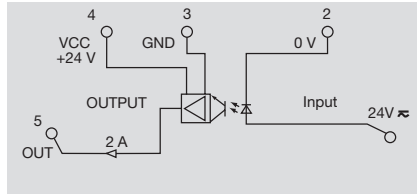
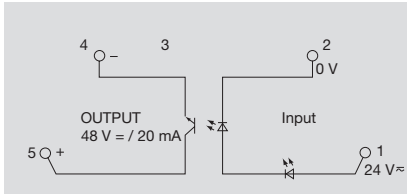

Technical data

Control side

Rated voltage
Power rating
max. input frequency
Nominal auxiliary voltage
Status indicator

Load side

Nominal switching voltage
Nominal switching current
Voltage drop at max. load
Switch-on delay/Switch-off delay
Short-circuit-proof/Protective circuit

General data

Ambient temperature (operational)
Storage temperature
Approvals

Insulation coordination (EN 50 178)

Standards
Rated voltage
Rated impulse withstand voltage
Clearance and creepage distances for control side - load side
Surge category
Pollution severity

24 V DC ±20 %
230 mW / 280 mVA
AC: 5 Hz / DC: 10 Hz
no
LED green

5...48 V DC
20 mA
≤ 1 V
AC: 10 ms / DC: 20 ms / AC: 45 ms / DC: 40 ms
no /Integrated free-wheel diode

-25 °C...+50 °C
-40 °C...+85 °C
CSA;cURus;CE;

EN 50178
300 V
6.0 kV
≥ 5.5 mm
III
2

24 V DC ±20 %
195 mW / 220 mVA
AC: 10 Hz / DC: 30 Hz
no
LED *

24 V DC ±20%
2 A
/
yes /varistor

-25 °C...+40 °C
-40 °C...+60 °C
CSA;cURus;CE;

EN 50178
300 V
6.0 kV
≥ 5.5 mm
III
2

Dimensions

Clamping range (rating- / min. / max.) mm²
Length x width x height mm

Note

Tension clamp connection

1.5 / 0.5 / 1.5
91 x 6 x 64

Tension clamp connection

1.5 / 0.5 / 1.5
91 x 6 x 64

* Status indicator: green = OK,
yellow = partial short circuit, blinking red = short circuit

Ordering data

Connection system

Tension clamp connection

Note

Type	Qty.	Order No.
MCZ O 24VUC	10	8365940000

Type	Qty.	Order No.
MCZ O 24VUC	10	8287730000

Accessories

Note

End plate AP MCZ 1.5: 8389030000
for cross-connectors and markers - refer to MCZ Series accessories

End plate AP MCZ 1.5: 8389030000
for cross-connectors and markers - refer to MCZ Series accessories

Optos - MCZ-SERIES

MiniConditioner MCZ O

- Universal interface between control and sensor/actuator
- Tension clamp connection system
- Plug-in cross-connection
- Width 6mm

120 V UC



230 V AC



C

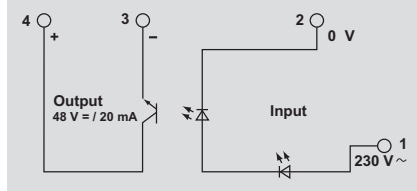
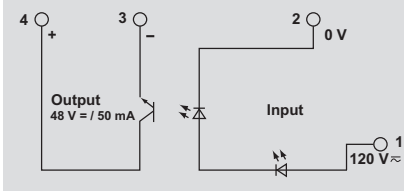

Technical data

Control side

Rated voltage
Power rating
max. input frequency
Nominal auxiliary voltage
Status indicator

Load side

Nominal switching voltage
Nominal switching current
Voltage drop at max. load
Switch-on delay/Switch-off delay
Short-circuit-proof/Protective circuit

General data

Ambient temperature (operational)
Storage temperature
Approvals

Insulation coordination (EN 50 178)

Standards
Rated voltage
Rated impulse withstand voltage
Clearance and creepage distances for control side - load side
Surge category
Pollution severity

Rated voltage	120 V UC +5/-15 %
Power rating	350 mW / 400 mVA
max. input frequency	AC: 5 Hz duty factor 1:2, DC: 20 Hz duty factor 1:2
Nominal auxiliary voltage	no
Status indicator	LED green
Nominal switching voltage	5...48 V DC
Nominal switching current	50 mA
Voltage drop at max. load	≤ 1,6 V
Switch-on delay/Switch-off delay	≤ 30 ms / ≤ 40 ms
Short-circuit-proof/Protective circuit	no /Integrated free-wheel diode
Ambient temperature (operational)	-25 °C...+40 °C
Storage temperature	-40 °C...+60 °C
Approvals	CSA;cURus;CE;
Standards	EN 50178
Rated voltage	300 V
Rated impulse withstand voltage	6.0 kV
Clearance and creepage distances for control side - load side	≥ 5.5 mm
Surge category	III
Pollution severity	2

Rated voltage	230 V AC +5 %/ -15 %
Power rating	2.3 VA
max. input frequency	AC: 5 Hz duty factor 1:2
Nominal auxiliary voltage	no
Status indicator	LED green
Nominal switching voltage	5...48 V DC
Nominal switching current	20 mA
Voltage drop at max. load	≤ 1,6 V
Switch-on delay/Switch-off delay	≤ 30 ms / ≤ 40 ms
Short-circuit-proof/Protective circuit	no /Integrated free-wheel diode
Ambient temperature (operational)	-25 °C...+40 °C
Storage temperature	-40 °C...+85 °C
Approvals	CSA;cURus;CE;
Standards	EN 50178
Rated voltage	300 V
Rated impulse withstand voltage	6.0 kV
Clearance and creepage distances for control side - load side	≥ 5.5 mm
Surge category	III
Pollution severity	2

Dimensions

Clamping range (rating- / min. / max.) mm²
Length x width x height mm

Note

Tension clamp connection

1.5 / 0.5 / 1.5
91 x 6 x 64

Tension clamp connection

1.5 / 0.5 / 1.5
91 x 6 x 64

Ordering data

Connection system
Tension clamp connection

Note

Type	Qty.	Order No.
MCZ O 120VUC	10	8421060000

Type	Qty.	Order No.
MCZ O 230VAC	10	8421380000

Accessories

Note

End plate AP MCZ 1.5: 8389030000
for cross-connectors and markers - refer to MCZ Series accessories

End plate AP MCZ 1.5: 8389030000
for cross-connectors and markers - refer to MCZ Series accessories

MiniConditioner MCZ O

Module can be used as an universal interface:

- Between control and actuator, to convert signals from 24 Vdc to 5 VTTL
- Between control and actuator, to convert signals from 5 VTTL to 5...48 Vdc

24 V DC / 5 V TTL

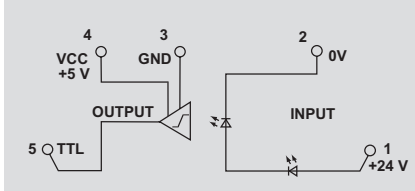

5 V TTL / 5...48 V DC

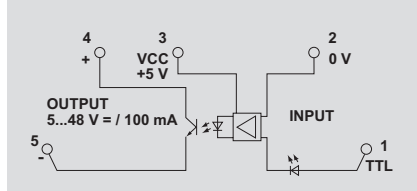

Technical data

Control side

Rated voltage
Power rating
max. input frequency
Nominal auxiliary voltage
Status indicator

Load side

Nominal switching voltage
Nominal switching current
Voltage drop at max. load
Switch-on delay/Switch-off delay
Short-circuit-proof/Protective circuit

General data

Ambient temperature (operational)
Storage temperature
Approvals

Insulation coordination (EN 50 178)

Standards
Rated voltage
Rated impulse withstand voltage
Clearance and creepage distances for control side - load side
Surge category
Pollution severity

24 V DC ±16 %
112 mW
100 kHz duty factor 1:2, 50 kHz duty factor 1:10
no
LED green

5 V TTL(4.75...5.25 V)
8 mA, fan out = 20 LS-TTL
1 µs (at 20 V DC) /2.5 µs (at 28 V DC)
no /diode

-25 °C...+40 °C
-40 °C...+60 °C
CSA;cURus;CE;

EN 50178
300 V
6.0 kV
≥ 5.5 mm
III
2

5 V TTL
10 mW
2.4 kHz
5 V
LED green

5...48 V DC
100 mA
≤ 1,8 V
/
no /diode

-25 °C...+50 °C
-40 °C...+85 °C
CSA;cURus;CE;

EN 50178
300 V
6.0 kV
≥ 5.5 mm
III
2

Dimensions

Clamping range (rating- / min. / max.) mm²
Length x width x height mm

Note

Tension clamp connection

1.5 / 0.5 / 1.5
91 x 6 x 64

Tension clamp connection

1.5 / 0.5 / 1.5
91 x 6 x 64

Ordering data

Connection system

Tension clamp connection

Note

Type	Qty.	Order No.
MCZ O 24VDC	10	8324610000

Type	Qty.	Order No.
MCZ O 5VTTL	10	8398940000

Accessories

Note

End plate AP MCZ 1.5: 8389030000
for cross-connectors and markers - refer to MCZ Series accessories

End plate AP MCZ 1.5: 8389030000
for cross-connectors and markers - refer to MCZ Series accessories

Optos - MCZ-TRAK-SERIES

MCZ O TRAK

- Module for rail industry applications
- Meets requirements of EN 50155
- Power fluctuations -30 %/+25 %
- Operating temperature -25...+70 °C (85 °C / 10 min.) as per EN 50155
- Condensation permissible

24 V DC TRAK



C

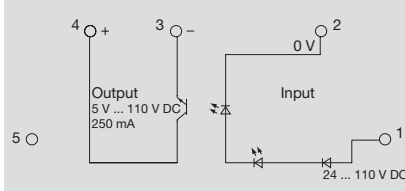

Technical data

Control side

Rated voltage
Power rating
max. input frequency
Nominal auxiliary voltage
Status indicator

24...110 V DC -30/+25%

10 Hz

no

LED green

Load side

Nominal switching voltage
Nominal switching current
Voltage drop at max. load
Switch-on delay/Switch-off delay
Short-circuit-proof/Protective circuit

5...137.5 V DC

250 mA @ 50 °C ;180 mA @ 70 °C

≤ 1.7 V

10 ms /50 ms

/Varistor, integral free-wheel diode

General data

Ambient temperature (operational)
Storage temperature
Approvals

+85°C for 10 minutes ; -25 °C...+70 °C

-40 °C...+85 °C

CE;

Insulation coordination (EN 50 178)

Standards
Rated voltage
Rated impulse withstand voltage
Clearance and creepage distances for control side - load side
Surge category
Pollution severity

EN 50178

300 V

6.0 kV

≥ 5.5 mm

III

2

Dimensions

Clamping range (rating- / min. / max.) mm²
Length x width x height mm

Tension clamp connection

1.5 / 0.5 / 1.5

91 x 6 x 64

Note

Ordering data

Connection system

Tension clamp connection

Type	Qty.	Order No.
MCZ O TRAK 24.110VDC	10	8820710000

Note

Accessories

Note

End plate AP MCZ 1.5: 8389030000
for cross-connectors and markers - refer to MCZ Series accessories

MCZ accessories

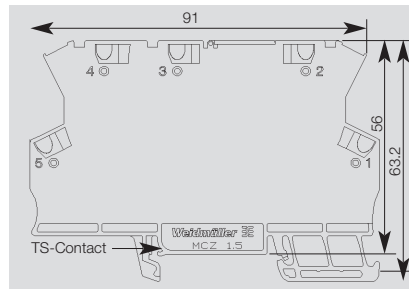

Ordering data

Type	Qty	Order No.
End plate	50	8389030000

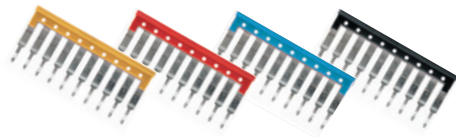

Ordering data

No. of poles	Type	Qty	Order No.
2	ZQV 4N / 2 GE	60	1758250000
3	ZQV 4N / 3 GE	60	1762630000
4	ZQV 4N / 4 GE	60	1762620000
10	ZQV 4N / 10 GE	20	1758260000
20	ZQV 4N / 20 GE	20	1909020000
2	ZQV 4N / 2 RT	60	1793950000
3	ZQV 4N / 3 RT	60	1793980000
4	ZQV 4N / 4 RT	60	1794010000
10	ZQV 4N / 10 RT	20	1794040000
20	ZQV 4N / 20 RT	20	1909150000
2	ZQV 4N / 2 BL	60	1793960000
3	ZQV 4N / 3 BL	60	1793990000
4	ZQV 4N / 4 BL	60	1794020000
10	ZQV 4N / 10 BL	20	1794050000
20	ZQV 4N / 20 BL	20	1909100000
2	ZQV 4N / 2 SW	60	1793970000
3	ZQV 4N / 3 SW	60	1794000000
4	ZQV 4N / 4 SW	60	1794030000
10	ZQV 4N / 10 SW	20	1794060000
20	ZQV 4N / 20 SW	20	1909120000

Ordering data

Type	Qty	Order No.
Marker	200	1060960000



Optos - MICROSERIES

MOS / MOZ 3...48 V DC / 0.1 A

Universal interface between control and sensor/actuator

- Plug-in cross-connection ZQV 4N
- Interchangeable solid-state relay
- 6.1 mm wide
- Screw or tension clamp connection
- For mounting on TS 35

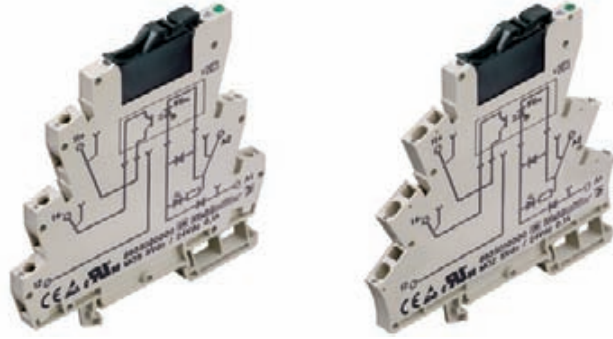

Load side	
Nominal switching voltage	3...48 V DC
Nominal switching current	0.1 A
Voltage drop at max. load	≤ 1 V
Leakage current	≤ 1 mA
Short-circuit-proof/Protective circuit	no/Integrated free-wheel diode
General data	
Ambient temperature (operational)	-25 °C...+50 °C
Storage temperature	-40 °C...+60 °C
Approvals	CE; cULus;
Insulation coordination (EN 50 178)	
Standards	EN 50178
Rated voltage	300 V
Rated impulse withstand voltage	4.0 kV
Clearance and creepage distances for control/load side	≥ 5.5 mm
Surge category	III
Pollution severity	2
Dimensions	
Clamping range (rating- / min. / max.)	mm ²
Length x width x height	mm
Screw connection	
Clamping range (rating- / min. / max.)	mm ²
Length x width x height	mm
Tension clamp connection	
Clamping range (rating- / min. / max.)	mm ²
Length x width x height	mm
Note	Cross-connectors and markers - refer to MICROSERIES accessories

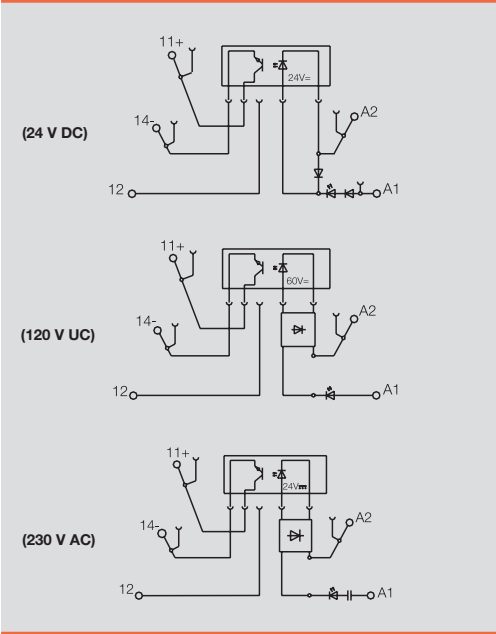

Ordering data

Control side	
Rated voltage	5 V DC ±20%
Power rating	55 mW ±10 %
max. input frequency	10 Hz
Switch-on delay	< 6,5 ms
Switch-off delay	< 10 ms

5 V DC / 24 V DC 0.1 A	
Rated voltage	5 V DC ±20%
Power rating	55 mW ±10 %
max. input frequency	10 Hz
Switch-on delay	< 6,5 ms
Switch-off delay	< 10 ms

24 V DC / 24 V DC 0,1 A	
Rated voltage	24 V DC ±20 %
Power rating	140 mW
max. input frequency	300 Hz
Switch-on delay	35µs
Switch-off delay	355µs

120 V UC / 24 V DC 0,1 A	
Rated voltage	120 V UC + 10 % / -15 %
Power rating	340 mW / 0.4 VA
max. input frequency	DC: 10 Hz / AC: 3 Hz
Switch-on delay	< 6.5 ms
Switch-off delay	< 10 ms

230 V AC / 24 V DC 0,1 A	
Rated voltage	230 V AC ±10%
Power rating	1.7 VA
max. input frequency	3 Hz
Switch-on delay	< 6.5 ms
Switch-off delay	< 10 ms

Ordering data Complete module	
Screw connection	Type: MOS 5Vdc / 24Vdc 0,1A
Order No.	8633020000
Tension clamp connection	Type: MOZ 5Vdc / 24Vdc 0,1A
Order No.	8633010000

Ordering data Complete module	
Screw connection	Type: MOS 24Vdc / 24Vdc 0,1A
Order No.	8607340000
Tension clamp connection	Type: MOZ 24Vdc / 24Vdc 0,1A
Order No.	8607360000

Ordering data Complete module	
Screw connection	Type: MOS 120Vuc / 24Vdc 0,1A
Order No.	8607690000
Tension clamp connection	Type: MOZ 120Vuc / 24Vdc 0,1A
Order No.	8607730000

Ordering data Complete module	
Screw connection	Type: MOS 230Vac / 24Vdc 0,1A
Order No.	8607710000
Tension clamp connection	Type: MOZ 230Vac / 24Vdc 0,1A
Order No.	8607750000

Ordering data Spare relay, pluggable	
Type	SSS Relais 5V/24V 0,1Adc
Order No.	4064320000
Type	SSS Relais 24V/24V 0,1Adc
Order No.	4061180000
Type	SSS Relais 60V/24V 0,1Adc
Order No.	4061230000
Type	SSS Relais 24V/24V 0,1Adc
Order No.	4061180000

Note

MOS / MOZ 24...240 V AC / 1 A

Universal interface between control and sensor/actuator

- Plug-in cross-connection ZQV 4N
- Interchangeable solid-state relay
- 6.1 mm wide
- Screw or tension clamp connection
- For mounting on TS 35

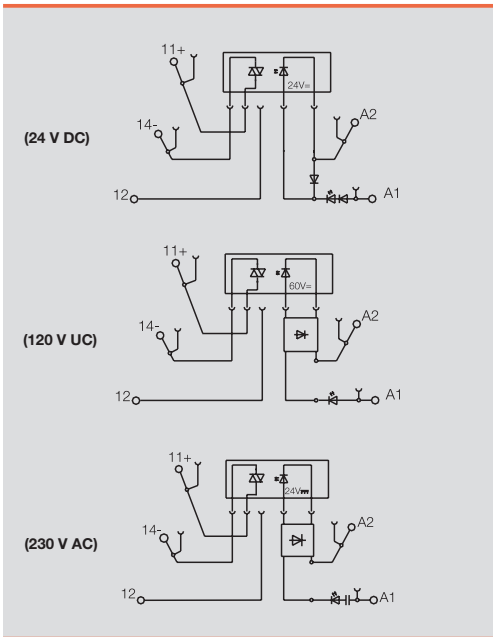
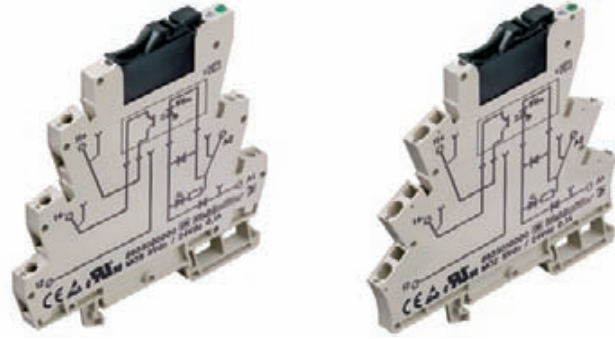

Load side	
Nominal switching voltage	24...240 V AC
Nominal switching current	1 A
Voltage drop at max. load	approx. 1.6 V
Leakage current	≤ 20 µA
Short-circuit-proof/Protective circuit	no/Integrated free-wheel diode
General data	
Ambient temperature (operational)	-25 °C...+50 °C
Storage temperature	-40 °C...+60 °C
Approvals	CE; cULus;
Insulation coordination (EN 50 178)	
Standards	EN 50178
Rated voltage	300 V
Rated impulse withstand voltage	4.0 kV
Clearance and creepage distances for control/load side	≥ 5.5 mm
Surge category	III
Pollution severity	2
Dimensions	
Clamping range (rating- / min. / max.)	mm ²
Length x width x height	mm
Screw connection	
Clamping range (rating- / min. / max.)	mm ²
Length x width x height	mm
Tension clamp connection	
Clamping range (rating- / min. / max.)	mm ²
Length x width x height	mm
Note	Cross-connectors and markers - refer to MICROSERIES accessories

Ordering data

Control side	24 V DC / 230 V AC 1 A	120 V UC / 230 V AC 1 A	230 V AC / 230 V AC 1 A
Rated voltage	24 V DC ±20 %	120 V UC + 10% / -15 %	230 V UC ±10 %
Power rating	250 mW ± 15 %	0.4 VA ±15%	1,7 VA ± 20%
max. input frequency	3 Hz	3 Hz	3 Hz
Switch-on delay	< 11 ms	< 11 ms	< 20 ms
Switch-off delay	< 11 ms	< 11 ms	< 20 ms

Ordering data

Complete module		24 V DC / 230 V AC 1 A	120 V UC / 230 V AC 1 A	230 V AC / 230 V AC 1 A
Screw connection	Type	MOS 24Vdc/ 230VAC 1A	MOS 120Vuc / 230VAC 1A	MOS 230Vuc/ 230Vac 1A
	Order No.	8652010000	8651930000	8651990000
Tension clamp connection	Type	MOZ 24Vdc/ 230VAC 1A	MOZ 120Vuc / 230VAC 1A	MOZ 230Vuc/ 230VAC 1A
	Order No.	8652020000	8651950000	8651970000
Spare relay, pluggable				
	Type	SSS Relais 24V/230V 1Aac	SSS Relais 60V/230V 1Aac	SSS Relais 24V/230V 1Aac
	Order No.	4061210000	4061220000	4061210000

Note

Optos - MICROSERIES

MOS / MOZ 3...33 V DC / 2 A

Universal interface between control and sensor/actuator

- Plug-in cross-connection ZQV 4N
- Interchangeable solid-state relay
- 6.1 mm wide
- Screw or tension clamp connection
- For mounting on TS 35

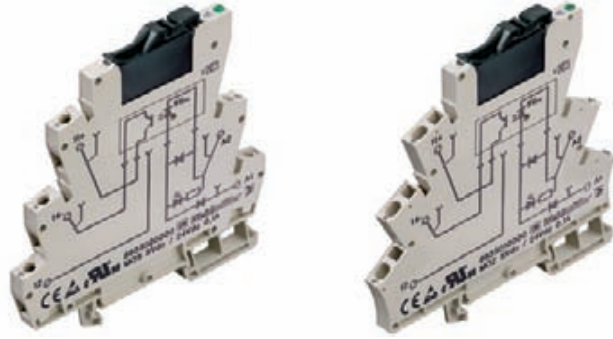

Load side	
Nominal switching voltage	3...33 V DC
Nominal switching current	2 A
Voltage drop at max. load	≤ 120 mV
Leakage current	≤ 1 mA
Short-circuit-proof/Protective circuit	no/Integrated free-wheel diode
General data	
Ambient temperature (operational)	-25 °C...+50 °C
Storage temperature	-40 °C...+60 °C
Approvals	CE; cULus;
Insulation coordination (EN 50 178)	
Standards	EN 50178
Rated voltage	300 V
Rated impulse withstand voltage	4.0 kV
Clearance and creepage distances for control/load side	≥ 5.5 mm
Surge category	III
Pollution severity	2
Dimensions	
Clamping range (rating- / min. / max.)	mm ²
Length x width x height	mm
Screw connection	
Clamping range (rating- / min. / max.)	mm ²
Length x width x height	mm
Tension clamp connection	
Clamping range (rating- / min. / max.)	mm ²
Length x width x height	mm
Note	Cross-connectors and markers - refer to MICROSERIES accessories

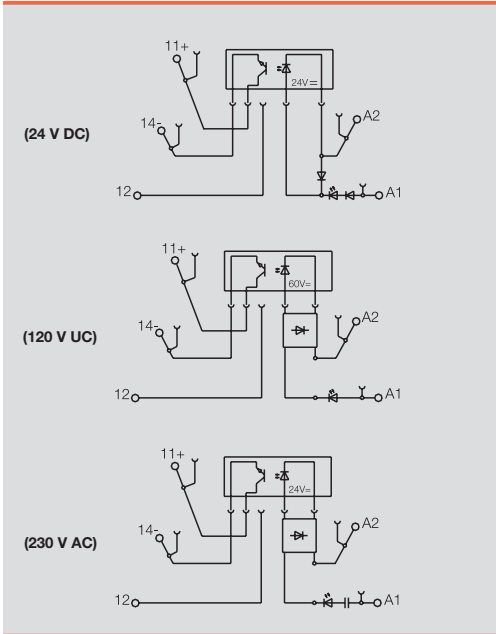

Ordering data

Control side	5 V DC / 24 V DC 2 A	24 V DC / 24 V DC 2 A	120 V UC / 24 V DC 2 A	230 V AC / 24 V DC 2 A
Rated voltage	5 V DC ±20%	24 V DC ±20 %	120 V UC + 10 % / -15 %	230 V AC ±10%
Power rating	55 mW ±10 %	140 mW	340 mW / 0.4 VA	1.7 VA
max. input frequency	300 Hz	300 Hz	DC: 10 Hz / AC: 3 Hz	3 Hz
Switch-on delay	< 55 µs	< 55 µs	< 6.5 ms	< 6.5 ms
Switch-off delay	< 1 ms	< 1.2 ms	< 10 ms	< 10 ms

Ordering data Complete module		5 V DC / 24 V DC 2 A	24 V DC / 24 V DC 2 A	120 V UC / 24 V DC 2 A	230 V AC / 24 V DC 2 A
Screw connection	Type	MOS 5Vdc / 24Vdc 2A	MOS 24Vdc / 24Vdc 2A	MOS 120Vuc / 24Vdc 2A	MOS 230Vac / 24Vdc 2A
	Order No.	8633000000	8607350000	8607700000	8607720000
Tension clamp connection	Type	MOZ 5Vdc / 24Vdc 2A	MOZ 24Vdc / 24Vdc 2A	MOZ 120Vuc / 24Vdc 2A	MOZ 230Vac / 24Vdc 2A
	Order No.	8632990000	8607370000	8607740000	8607760000
Ordering data Spare relay, pluggable					
	Type	SSS Relais 5V/24V 2ADC	SSS Relais 24V/24V 2Acdc	SSS Relais 60V/24V 2Acdc	SSS Relais 24V/24V 2Acdc
	Order No.	4064310000	4061190000	4061200000	4061190000

Note					

Optos - MICROSERIES

Plug-in solid-state relay

SSS Relay

Switching current 100 mA

SSS Relay

Switching current 2 A

SSS Relay

Switching current 1 A



Technical data

Input	
	Nominal control voltage
Control voltage	min / max
Control current at $U_{IN} = 24\text{ V}$	
Drop-out voltage	
Control circuit resistance	
Output	
Switching voltage	
Switching/continuous current at $U_A > 5\text{ V DC}$	
Conducting-state voltage	
Insulation	
Test voltage between control/switching circuit	
Other data	
Operating temperature range	
Storage temperature range	
Weight	
Approvals	
* Ambient temperature 20 °C	
Wiring diagram	

For further data, see also <http://em.tycoelectronics.com>

24 V DC	60 V DC
Control voltage	16 V DC / 30 V DC
Control current at $U_{IN} = 24\text{ V}$	7 mA \pm 10 %
Drop-out voltage	10 V DC
Control circuit resistance	approx. 4 k Ω
Switching voltage	3 ... 48 V DC
Switching/continuous current at $U_A > 5\text{ V DC}$	100 mA DC
Conducting-state voltage	< 1 V DC
Test voltage between control/switching circuit	2.5 kV
Operating temperature range	-20 °C ... +60 °C
Storage temperature range	-40 °C ... +70 °C
Weight	3.65 g
Approvals	UL US

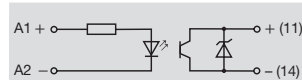

24 V DC	60 V DC
Control voltage	18 V DC / 30 V DC
Control current at $U_{IN} = 24\text{ V}$	7 mA \pm 10 %
Drop-out voltage	10 V DC
Control circuit resistance	approx. 3,2 k Ω
Switching voltage	3 ... 33 V DC
Switching/continuous current at $U_A > 5\text{ V DC}$	2 A DC
Conducting-state voltage	< 120 mV DC
Test voltage between control/switching circuit	2.5 kV
Operating temperature range	-20 °C ... +60 °C
Storage temperature range	-40 °C ... +70 °C
Weight	3.65 g
Approvals	UL US

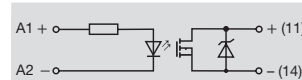

24 V DC	60 V DC
Control voltage	18 ... 30 V DC
Control current at $U_{IN} = 24\text{ V}$	3.1 mA \pm 10 %
Drop-out voltage	20 V DC
Control circuit resistance	20 k Ω
Switching voltage	24 ... 240 V AC
Switching/continuous current at $U_A > 5\text{ V DC}$	1 A AC
Conducting-state voltage	< 1 V AC
Test voltage between control/switching circuit	2.5 kV
Operating temperature range	-20 °C ... +60 °C
Storage temperature range	-40 °C ... +70 °C
Weight	3.65 g
Approvals	UL US

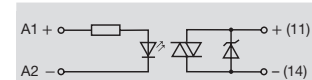

Ordering data

Nominal control voltage	Type	Order No.
5 V DC	SSS Relais 5 V/24 V 0,1 A DC	4064320000
24 V DC	SSS Relais 24 V/24 V 0,1 A DC	4061180000
60 V DC	SSS Relais 60 V/24 V 0,1 A DC	4061230000

Nominal control voltage	Type	Order No.
5 V DC	SSS Relais 5 V / 24 V 2 A DC	4064310000
24 V DC	SSS Relais 24 V/24 V 2 A DC	4061190000
60 V DC	SSS Relais 60 V/24 V 2 A DC	4061200000

Nominal control voltage	Type	Order No.
24 V DC	SSS Relais 24 V/230 V 1 A AC	4061210000
60 V DC	SSS Relais 60 V/230 V 1 A AC	4061220000

Dimensions

Printing details

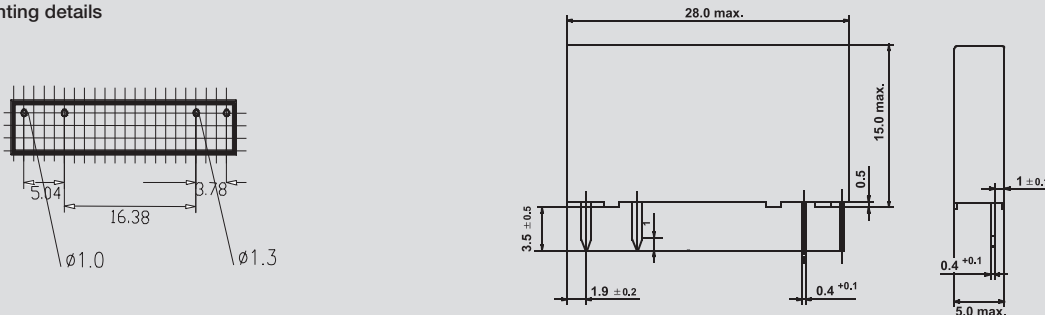

Accessories

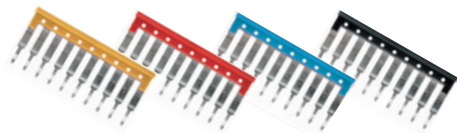

Plug-in cross-connection

Type	No. of poles	Qty	Order No.
yellow			
ZQV 4N / 2 GE	2	60	1758250000
ZQV 4N / 3 GE	3	60	1762630000
ZQV 4N / 4 GE	4	60	1762620000
ZQV 4N / 10 GE	10	20	1758260000
ZQV 4N / 20	20	20	1909020000
red			
ZQV 4N / 2 RT	2	60	1793950000
ZQV 4N / 3 RT	3	60	1793980000
ZQV 4N / 4 RT	4	60	1794010000
ZQV 4N / 10 RT	10	20	1794040000
ZQV 4N / 20 RT	20	20	1909150000
blue			
ZQV 4N / 2 BL	2	60	1793960000
ZQV 4N / 3 BL	3	60	1793990000
ZQV 4N / 4 BL	4	60	1794020000
ZQV 4N / 10 BL	10	20	1794050000
ZQV 4N / 20 BL	20	20	1909100000
black			
ZQV 4N / 2 SW	2	60	1793970000
ZQV 4N / 3 SW	3	60	1794000000
ZQV 4N / 4 SW	4	60	1794030000
ZQV 4N / 10 SW	10	20	1794060000
ZQV 4N / 20 SW	20	20	1909120000

Other accessories

Type		Qty	Order No.
Base only			
MRZ 24VDC 1CO BASIS		10	8826000000
MRS 24VDC 1CO BASIS		10	8826010000
MRZ 120VUC 1CO BASIS		10	8826020000
MRS 120VUC 1CO BASIS		10	8826030000
MRZ 230VAC 1CO BASIS		10	8826040000
MRS 230VAC 1CO BASIS		10	8826050000
Markers			
WS 12/6	12 x 6 mm	200	1061160000
Labels, Lasermark			
LM MT 300 15/6 ge	484 labels / sheet	10	1686360000
Screwdriver			
SD 0,6 x 3,5 x 100		10	9008330000

General data – MICROSERIES

Technical data

Conductor		Tension clamp connection	Screw connection
Solid H07V-U	mm ²	0.5 ... 2.5	0.5 ... 4.0
Stranded H07V-K	mm ²	0.5 ... 2.5	0.5 ... 2.5
*F with wire end ferrules to DIN 46228-1	mm ²	0.5 ... 1.5	0.5 ... 1.5
*F with wire end ferrules with plastic collar	mm ²	0.5 ... 1.5	0.5 ... 1.5
Max. clamping range	mm ²	0.13 ... 2.5	0.13 ... 4.0
Plug gauge to IEC 60947-1	size	A 2	A 3

General technical data

Nominal torque		-	0.6
Continuous current for 2-pole cross-connection	A	10	10
Continuous current for multi-pole cross-connection	A	10	10
Stripping length	mm	10	7
Ingress protection class		IP 20	IP 20
Housing material		Wemid	Wemid
UL 94 flammability rating		V-0	V-0
Nominal current	A	6	6
Nominal voltage	V	250	250

Dimensions

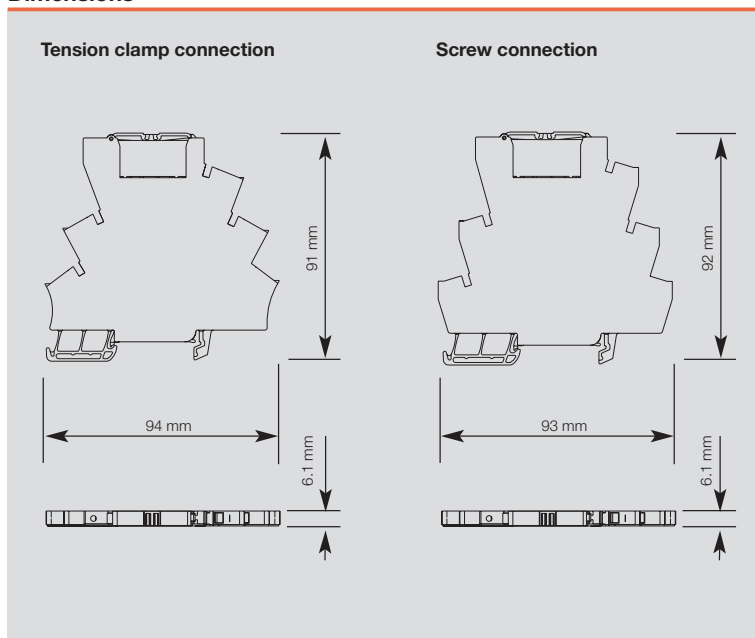

C

Optokoppler - MICROOPTO

For high switching frequency up to 100kHz

- Only 6 mm width
- Pluggable cross-connection
- Mount onto TS35

12...28 V DC 100 kHz



C

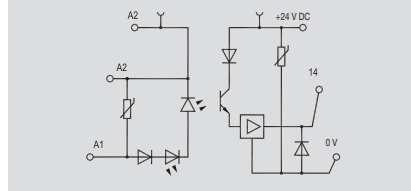

A special interior circuit in the opto module **MICROOPTO 100 kHz** ensures that rapidly transmitted signals are isolated from one another and that they can be transferred practically without delay. This allows switching frequencies up to 100 kHz to be achieved.

Comprehensive suppressor circuits safeguard the module against conducted transients and voltage spikes

Technical data

Control side

Rated voltage
Power rating
Making voltage
Dropout voltage
max. input frequency
Status indicator
Protective circuit

12 V DC...28 V DC
0.08...0.3 W
> 70 % U_{Nom}
< 12 V
100 kHz
LED green
Varistor, reverse polarity protection

Load side

Solid-state type
Nominal switching voltage
Nominal switching current
Voltage drop at max. load
Leakage current
Short-circuit-proof/Protective circuit
Switch-on delay/Switch-off delay
Continuous current
Pulse loading, max. current/Fuse
Load category

Bipolar transistor
24 V DC
50 mA
≤ 1,5 V
< 20 μA>
no /varistor, reverse polarity protection
< 1 μs> / < 3 μs
50 mA
0.6 A (20 ms)/
LC A

General data

Ambient temperature (operational)
Storage temperature
UL 94 flammability class
Humidity

-20 °C...+60 °C
-40 °C...+80 °C
V-0
5...95 % RH
 $T_{11} = 40 °C$, no condensation
CE; cULus in preparation
EN 50178, IEC 62314, UL508

Approvals
Standards

Insulation coordination (EN 50 178)

Rated voltage
Rated impulse withstand voltage
Clearance and creepage distances for control side - load side
Surge category
Pollution severity

300 V
2.5 kV
> 3 mm
III
2

Dimensions

Clamping range (rating- / min. / max.) mm²
Length x width x height mm

Screw connection

2.5 / 0.5 / 4
90 x 6.1 x 98

Note

Ordering data

Connection system

Screw connection

Type	Qty.	Order No.
MOS 12-28VDC 100kHz	1	8937990000

Note

Accessories

Note

For example rotational speed measurement

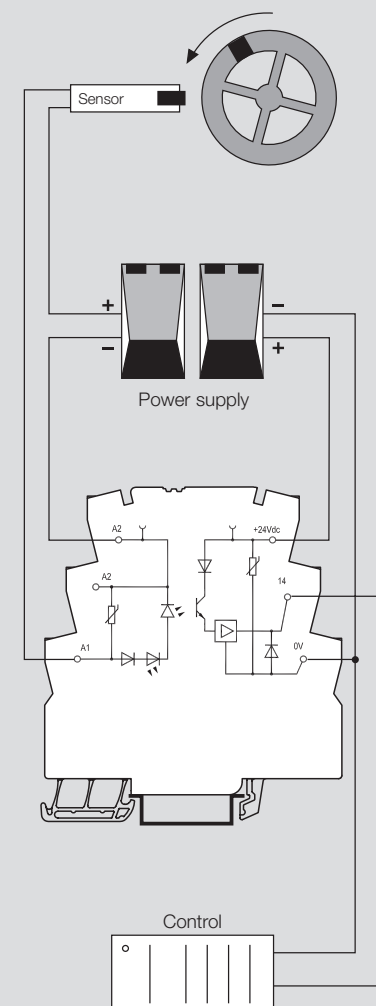

For DC loads up to 300 V DC and 1 A

- Only 6 mm width
- Plug-in cross-connection
- Power Boost: 20 A / 20 ms, 5 A / 1 sec

12...300 V DC 1 A

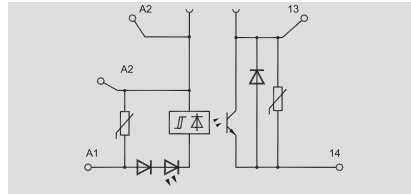
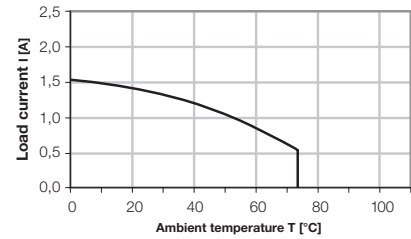

The solid-state relay **MICROOPTO 300 V DC** has been developed as a switching amplifier for high inductive loads up to 300 V DC and 1 A in motor brakes and contactors.

A power boost in the load circuit compensates transient overloads (20 A for 20 ms / 5 A for 1 s) such as making or breaking spikes. Additional protective circuits counter higher overloads.

Technical data

Control side

- Rated voltage
- Power rating
- Making voltage
- Dropout voltage
- max. input frequency
- Status indicator
- Protective circuit

- 24 V DC ±20 %
- 0.26 W
- 19.6 V DC
- < 12 V
- 100 Hz
- LED green
- Varistor, reverse polarity protection

Load side

- Solid-state type
- Nominal switching voltage
- Nominal switching current
- Voltage drop at max. load
- Leakage current
- Short-circuit-proof/Protective circuit
- Switch-on delay/Switch-off delay
- Continuous current
- Pulse loading, max. current/Fuse
- Load category

- MOS-FET
- 12...300 V DC
- 1 A
- < 1 V
- < 100 µA>
- Powerboost 20 A / 20 ms, 5 A / 1 sec /varistor
- < 0.2 ms / < 0.3 ms
- 1 A
- 27 A (10 ms)/
- LC A

General data

- Ambient temperature (operational)
- Storage temperature
- UL 94 flammability class
- Humidity

- 20 °C...+60 °C
- 40 °C...+80 °C
- V-0
- 5...95 % RH
- T_{st} = 40°C, no condensation
- CE; cULus in preparation
- EN 50178, IEC 62314, UL508

Approvals

Standards

Insulation coordination (EN 50 178)

- Rated voltage
- Rated impulse withstand voltage
- Clearance and creepage distances for control side - load side
- Surge category
- Pollution severity

- 300 V
- 2.5 kV
- > 3 mm
- III
- 2

Dimensions

- Clamping range (rating- / min. / max.) mm²
- Length x width x height mm

Screw connection

- 2.5 / 0.5 / 4
- 90 x 6.1 x 98

Note

Ordering data

Connection system

Screw connection

Type	Qty.	Order No.
MOS 24VDC/12-300VDC 1A	1	8937830000

Note

Accessories

Note

Example: motor brake

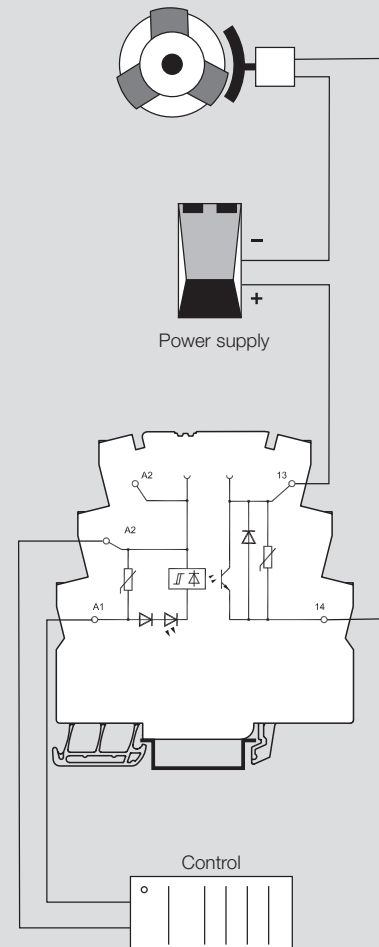

Solid-state relay - MICROOPTO

For direct connection of actuators up to 24 V DC, 2 A

- Only 6 mm width
- Pluggable cross-connection
- PE connection integrated in mounting rail
- Fault indication via LED

8...30 V DC 2 A



n

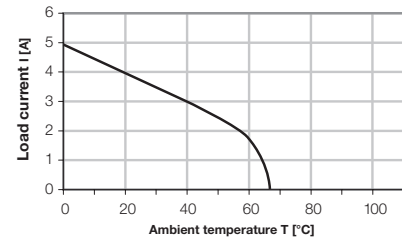

C

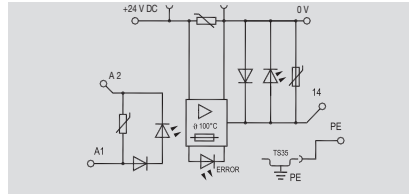

The solid-state relay **MICROOPTO ACTOR** has been especially designed as a switching amplifier for actuators up to 24 V DC and 2A with inductive loads such as solenoid valves and contactors. 3-wire actuators can be connected directly to the module.

This is short-circuit proof and protected against application-related transients and spikes by extensive protective circuitry.

Technical data

Control side

Rated voltage
Power rating
Making voltage
Dropout voltage
max. input frequency
Status indicator
Protective circuit

Load side

Solid-state type
Nominal switching voltage
Nominal switching current
Voltage drop at max. load
Leakage current
Short-circuit-proof/Protective circuit
Switch-on delay/Switch-off delay
Continuous current
Pulse loading, max. current/Fuse
Load category

General data

Ambient temperature (operational)
Storage temperature
UL 94 flammability class
Humidity

Approvals
Standards

Insulation coordination (EN 50 178)

Rated voltage
Rated impulse withstand voltage
Clearance and creepage distances for control side - load side
Surge category
Pollution severity

Dimensions

Clamping range (rating- / min. / max.) mm²
Length x width x height mm

Note

Ordering data

Connection system

Screw connection

Note

Accessories

Note

24 V DC $\pm 20\%$
0.12 W
> 70 % U_{Nom}
< 12 V
100 Hz
Fault indication LED red, status LED green
Varistor, reverse polarity protection

Intelligent POWER MOS-FET

8...30 V DC
2 A
< 100 mV
< 100 μ A
yes (12 h) /varistor
< 0.2 ms> /< 0.5 ms>
2 A
/
LC A

-20 °C...+60 °C
-40 °C...+80 °C
V-0
5...95 % RH
 $T_{ref} = 40^{\circ}\text{C}$, no condensation
CE; cULus in preparation
EN 50178, IEC 62314, UL508

300 V
2.5 kV
> 3 mm
III
2

Screw connection

2.5 / 0.5 / 4
90 x 6.1 x 98

Type	Qty.	Order No.
MOS 24VDC/8-30VDC 2A	1	8937970000

Example: pneumatic valve

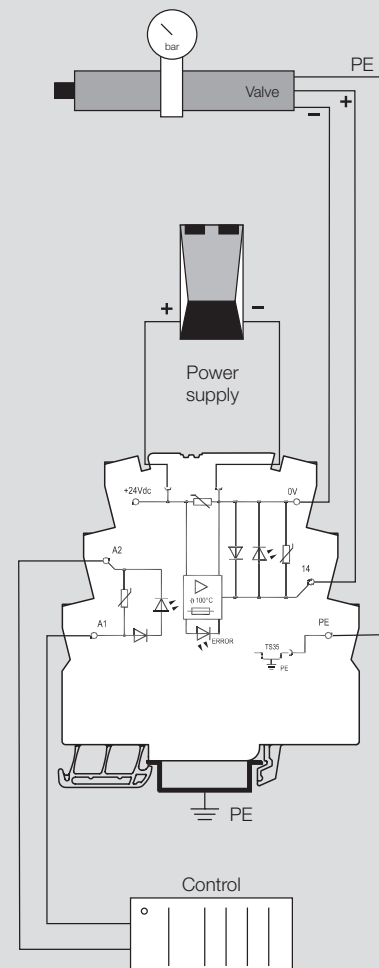

Optos - PLUGSERIES

POS / POZ

Universal interface between control and sensor

- Plug-in cross-connection ZQV 2.5N
- Interchangeable solid-state relay
- Screw or tension spring connection
- For mounting on TS 35

24 V DC / 24 V DC 2.5 A

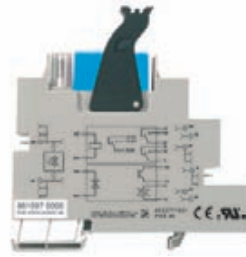

24 V DC / 24 V DC 5 A

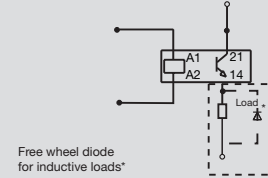
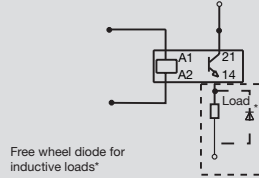
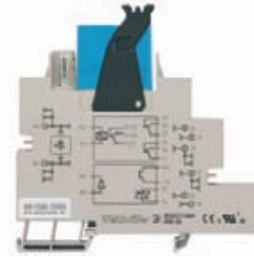

C

Technical data

Control side

Rated voltage
Power rating
Nominal auxiliary voltage
Status indicator

Load side

Nominal switching voltage
Nominal switching current
Voltage drop at max. load
Switch-on delay/Switch-off delay
Short-circuit-proof/Protective circuit

General data

Ambient temperature (operational)
Storage temperature
Approvals

Insulation coordination (EN 50 178)

Standards
Rated voltage
Rated impulse withstand voltage
Clearance and creepage distances for control side - load side
Surge category
Pollution severity

15 V DC...30 V DC
250 mW
no
green LED

0...30 V DC
2.5 A
≤ 0,4 V
2ms /18ms
no /Integrated free-wheel diode

-40 °C...+50 °C
-40 °C...+ 50 °C
CE:cURus;

EN 50178
300 V
2.5 kV_{eff}
8 mm
III
2

15 V DC...30 V DC
250 mW
no
green LED

0...30 V DC
5 A
≤ 0,3 V
2ms /18ms
no /Integrated free-wheel diode

-40 °C...+50 °C
-40 °C...+ 50 °C
CE:cURus;

EN 50178
300 V
2.5 kV_{eff}
8 mm
III
2

Dimensions

Clamping range (rating- / min. / max.) mm²
Length x width x height mm

Note

Screw connection

2.5 / 0.5 / 2.5
92 x 15.3 x 95

Tension clamp connection

2.5 / 0.5 / 2.5
92 x 15.3 x 87

Screw connection

2.5 / 0.5 / 2.5
92 x 15.3 x 95

Tension clamp connection

2.5 / 0.5 / 2.5
92 x 15.3 x 87

Ordering data

Connection system

Screw connection
Tension clamp connection

Note

Type

POS 24VDC/24VDC 2A
POZ 24VDC/24VDC 2A

Qty.

10
10

Order No.

8610840000
8610920000

Spare SSR 8576340000

Type

POS 24VDC/24VDC 5A
POZ 24VDC/24VDC 5A

Qty.

10
10

Order No.

8610900000
8610970000

Spare SSR 8576350000

Accessories

Note

Cross-connectors and markers - see PLUGSERIES accessories

Cross-connectors and markers - see PLUGSERIES accessories

POS / POZ

Universal interface between control and sensor

- Plug-in cross-connection ZQV 2.5N
- Interchangeable solid-state relay
- Screw or tension spring connection
- For mounting on TS 35

24 V DC / 230 V AC 2 A

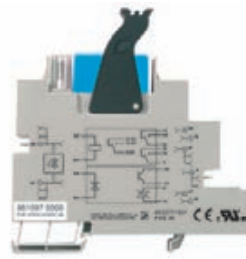

24 V DC / 230 V AC 4 A

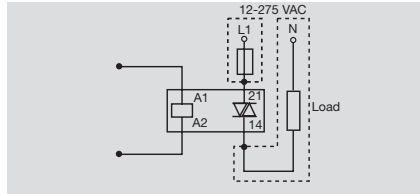
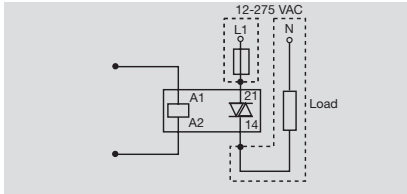
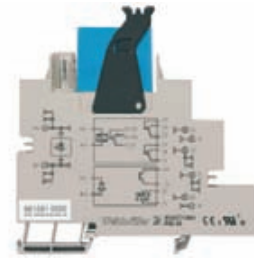

Technical data

Control side

Rated voltage
Power rating
Nominal auxiliary voltage
Status indicator

Load side

Nominal switching voltage
Nominal switching current
Voltage drop at max. load
Switch-on delay/Switch-off delay
Short-circuit-proof/Protective circuit

General data

Ambient temperature (operational)
Storage temperature
Approvals

Insulation coordination (EN 50 178)

Standards
Rated voltage
Rated impulse withstand voltage
Clearance and creepage distances for control side - load side
Surge category
Pollution severity

15 V DC...30 V DC
250 mW
no
green LED

12...275 V AC
2 A
≤ 1 V
12ms /20ms
no /RC element

-40 °C...+50 °C
-40 °C...+ 50 °C
CE:cURus;

EN 50178
300 V
4.0 kV_{eff}
8 mm
III
2

15 V DC...30 V DC
250 mW
no
green LED

12...275 V AC
3 A (4 A at 20°C)
≤ 1,1 V
12ms /20ms
no /RC element

-40 °C...+50 °C
-40 °C...+ 50 °C
CE:cURus;

EN 50178
300 V
4.0 kV_{eff}
8 mm
III
2

Dimensions

Clamping range (rating- / min. / max.) mm²
Length x width x height mm

Note

Screw connection

2.5 / 0.5 / 2.5
92 x 15.3 x 95

Tension clamp connection

2.5 / 0.5 / 2.5
92 x 15.3 x 87

Screw connection

2.5 / 0.5 / 2.5
92 x 15.3 x 95

Tension clamp connection

2.5 / 0.5 / 2.5
92 x 15.3 x 87

Ordering data

Connection system

Screw connection
Tension clamp connection

Type	Qty.	Order No.
POS 24VDC/230VAC 2A	10	8610860000
POZ 24VDC/230VAC 2A	10	8610930000

Type	Qty.	Order No.
POS 24VDC/230VAC 4A	10	8610910000
POZ 24VDC/230VAC 4A	10	8610980000

Note

Spare SSR 8576370000

Spare SSR 8576380000

Accessories

Note

Cross-connectors and markers - see PLUGSERIES accessories

Cross-connectors and markers - see PLUGSERIES accessories

Optos - PLUGSERIES

POS / POZ

Universal interface between control and sensor

- Plug-in cross-connection ZQV 2.5N
- Interchangeable solid-state relay
- Screw or tension spring connection
- For mounting on TS 35

24 V DC / 24 V UC 1 A

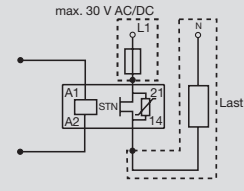
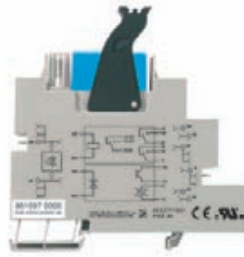

C

Technical data

Control side

Rated voltage
Power rating
Nominal auxiliary voltage
Status indicator

Load side

Nominal switching voltage
Nominal switching current
Voltage drop at max. load
Switch-on delay/Switch-off delay
Short-circuit-proof/Protective circuit

General data

Ambient temperature (operational)
Storage temperature
Approvals

Insulation coordination (EN 50 178)

Standards
Rated voltage
Rated impulse withstand voltage
Clearance and creepage distances for control side - load side
Surge category
Pollution severity

Rated voltage	15 V DC...30 V DC
Power rating	250 mW
Nominal auxiliary voltage	no
Status indicator	green LED
Nominal switching voltage	0...30 V UC
Nominal switching current	1 A
Voltage drop at max. load	≤ 0,9 V
Switch-on delay/Switch-off delay	5ms /12ms
Short-circuit-proof/Protective circuit	no /Integrated free-wheel diode
Ambient temperature (operational)	-40 °C...+50 °C
Storage temperature	-40 °C...+ 50 °C
Approvals	CE;cURus;
Standards	EN 50178
Rated voltage	300 V
Rated impulse withstand voltage	4.0 kV _{eff}
Clearance and creepage distances for control side - load side	8 mm
Surge category	III
Pollution severity	2

Dimensions

Clamping range (rating- / min. / max.) mm²
Length x width x height mm

Note

Screw connection	Tension clamp connection
2.5 / 0.5 / 2.5	2.5 / 0.5 / 2.5
92 x 15.3 x 95	92 x 15.3 x 87

Ordering data

Connection system	
Screw connection	
Tension clamp connection	

Note

Type	Qty.	Order No.
POS 24VDC/24VUC 1A	10	8610890000
POZ 24VDC/24VUC 1A	10	8610960000

Spare SSR 8576380000

Accessories

Note
Cross-connectors and markers - see PLUGSERIES accessories

Derating curves

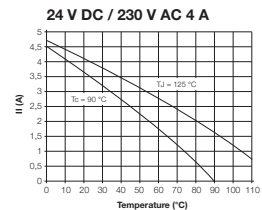
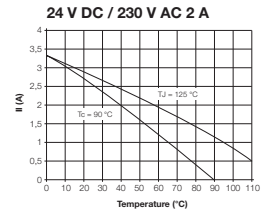
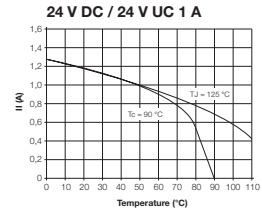
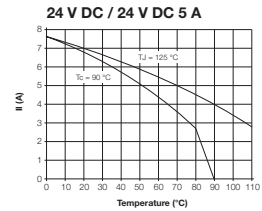
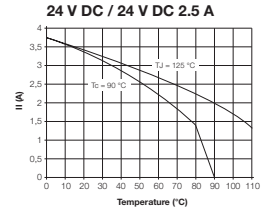

Accessories

PLUGSERIES

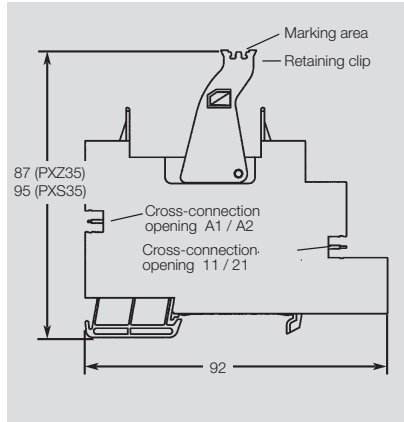

Technical data

Base without relay	
Nominal current	16 A
Nominal voltage	250 V
Dielectric strength coil/contact	> 4 kV
Ingress protection class	IP 20
Nominal cross-section	2.5 mm ²
Stripping length	8 mm
	10 mm
Ambient temperature	-40 °C ... +60 °C
UL 94 flammability rating	V-0

screw connection
tension clamp connection

Ordering data

Base for mounting on TS 35 rail		Type	Qty	Order No.
Screw connection		PXS35	10	8533771001
Tension clamp connection		PXZ35	10	8536691001

Retaining clip		Type	Qty	Order No.
		PRC	100	8536700000

LED indicator with free-wheel diode		Type	Qty	Order No.
6 ... 24 V DC		PLED 24 V DC	20	8536710000
red LED, 6 ... 24 V DC		PLED 24 V DC red	20	8611010000
48 ... 60 V DC		PLED 48 V DC	20	8536720000
115 V DC		PLED 115 V DC	20	8536730000
12 ... 24 V AC		PLED 24 V AC	20	8536750000
115 V AC		PLED 120 V AC	20	8536760000
230 V AC		PLED 230 V AC	20	8536780000
RC combination, 120 ... 230 V AC/DC		PLRC 200 nF/200 Ω	20	8566530000

Plug-in cross-connections		Type	Qty	Order No.
2-pole	black	ZQV 2.5N/4-2SW	60	1784270000
	red	ZQV 2.5N/4-2RT	60	1784280000
	blue	ZQV 2.5N/4-2BL	60	1784290000

Markers		Type	Qty	Order No.
	10 x 5 mm	WS 10/5	200	1060860000
	15 x 5 mm	WS 15/5	96	1609880000

Tension clamp connection

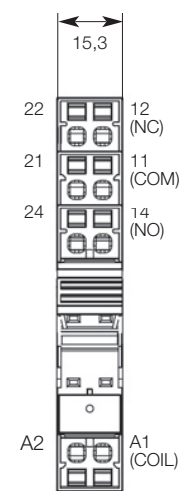

Screw connection

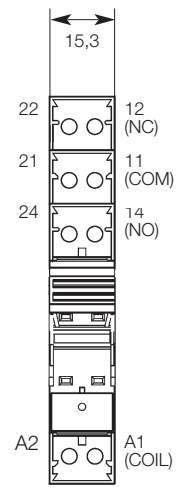

DC-Version

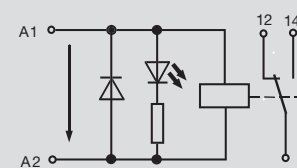

AC-Version

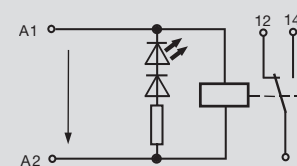

Optos - RSO-SERIES

RSO 30

- Plug-in connections
- DC output up to 3 A @ 5...60 V DC
- AC output up to 3 A @ 24...240 V AC
- 11 mm wide

RSO 30-DV/SC



RSO 30-DV/SA



C

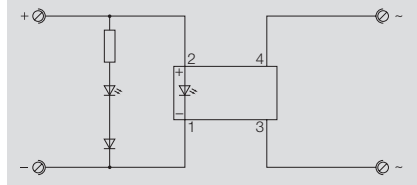
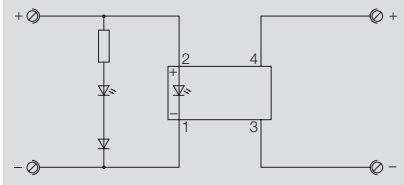

Technical data

Control side

Rated voltage
Power rating
Nominal auxiliary voltage
Status indicator

Load side

Nominal switching voltage
Nominal switching current
Voltage drop at max. load
Switch-on delay/Switch-off delay
Short-circuit-proof/Protective circuit

General data

Ambient temperature (operational)
Storage temperature
Approvals

Insulation coordination (EN 50 178)

Standards
Rated voltage
Rated impulse withstand voltage
Clearance and creepage distances for control side - load side
Surge category
Pollution severity

5...24 V DC ± 20%

no
LED green

2...60 V DC
3 A

0.1 ms / 0.75 ms
no /

-25 °C...+40 °C
-40 °C...+85 °C
CE;

EN 50178

300 V

4.0 kV

≥ 8 mm

III

2

5...24 V DC ± 20%

no
LED green

24...250 V AC
3 A

1.6 V
Zero-voltage switch /

-25 °C...+40 °C
-40 °C...+85 °C
CE;

EN 50178

300 V

4.0 kV

≥ 8 mm

III

2

Dimensions

Clamping range (rating- / min. / max.) mm²
Length x width x height mm

2.5 / 0.5 / 2.5
80 x 11 x 50

2.5 / 0.5 / 2.5
80 x 11 x 50

Note

Ordering data

Connection system

Type	Qty.	Order No.
RSO 30/DV 5-24V CC/SC	20	9443100000

Type	Qty.	Order No.
RSO 30/DV 5-24V CC/SA	20	9443110000

Note

Accessories

Note

RSO 31

- Plug-in connections
- DC output up to 3 A @ 5...60 V DC
- AC output up to 3 A @ 24...240 V AC
- 12.5 mm wide
- Plug-in fuse in output circuit

RSO 31 -ODC/F



RSO 31 -OAC/F

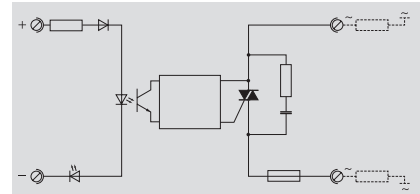
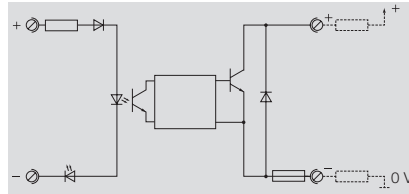

Technical data

Control side

Rated voltage
Power rating
Nominal auxiliary voltage
Status indicator

Load side

Nominal switching voltage
Nominal switching current
Voltage drop at max. load
Switch-on delay/Switch-off delay
Short-circuit-proof/Protective circuit

General data

Ambient temperature (operational)
Storage temperature
Approvals

Insulation coordination (EN 50 178)

Standards
Rated voltage
Rated impulse withstand voltage
Clearance and creepage distances for control side - load side
Surge category
Pollution severity

Rated voltage	24 V DC ±10%
Power rating	0.29 W
Nominal auxiliary voltage	no
Status indicator	LED red
Nominal switching voltage	5...50 V DC
Nominal switching current	3 A
Voltage drop at max. load	1.6 V
Switch-on delay/Switch-off delay	0.1 ms /0.75 ms
Short-circuit-proof/Protective circuit	no /
Ambient temperature (operational)	-25 °C...+40 °C
Storage temperature	-40 °C...+85 °C
Approvals	CE;
Standards	EN 50178
Rated voltage	300 V
Rated impulse withstand voltage	4.0 kV
Clearance and creepage distances for control side - load side	≥ 8 mm
Surge category	III
Pollution severity	2

Rated voltage	24 V DC ±10%
Power rating	0.29 W
Nominal auxiliary voltage	no
Status indicator	LED red
Nominal switching voltage	24...250 V AC
Nominal switching current	3 A
Voltage drop at max. load	1.6 V
Switch-on delay/Switch-off delay	No-voltage switch /
Short-circuit-proof/Protective circuit	no /
Ambient temperature (operational)	-25 °C...+40 °C
Storage temperature	-40 °C...+85 °C
Approvals	CE;
Standards	EN 50178
Rated voltage	300 V
Rated impulse withstand voltage	4.0 kV
Clearance and creepage distances for control side - load side	≥ 8 mm
Surge category	III
Pollution severity	2

Dimensions

Clamping range (rating- / min. / max.) mm²
Length x width x height mm

2.5 / 0.5 / 2.5
80 x 12.5 x 65.5

2.5 / 0.5 / 2.5
80 x 12.5 x 65.5

Note

Ordering data

Connection system

Type	Qty.	Order No.
RSO31-ODC24/F	20	9430820000

Type	Qty.	Order No.
RSO31-OAC24/F	20	9430320000

Note

Accessories

Note

Power solid-state relay

PSSR

- Load circuit 1-phase 12...275 VAC / 20 A
- Zero- voltage switching
- Ready-to-use: click on rail - wire up - ready
- Wear- & noiseless switching
- High peak current carrying capacity
I²t = 312 A²s (10 ms)

PSSR 24 V DC / 1 PH AC 20 A



C

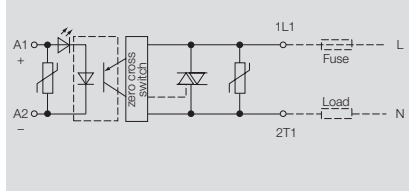

Technical data

Control side

Rated voltage	3...32 V DC
Power rating	0.03...0.3 W
Making voltage	3 V
Dropout voltage	1 V
max. input frequency	10 Hz
Status indicator	LED green
Protective circuit	varistor

Load side

Solid-state type	Triac
Nominal switching voltage	12...275 V
Nominal switching current	20 A @ 55 °C
Voltage drop at max. load	0.85 V
Leakage current	< 1 mA
Short-circuit-proof/Protective circuit	no /varistor
Switch-on delay/Switch-off delay	10 ms /10 ms
Continuous current	20 A
Pulse loading, max. current/Fuse	250 A (10 ms)/FERRAZ gRC 25 A 14x51 165 A ² s
Load category	AC 53: 5 A

General data

Ambient temperature (operational)	-30 °C...+80 °C
Storage temperature	-30 °C...+100 °C
UL 94 flammability class	40...85 % (indoor), no condensation
Humidity	CE, cURus
Approvals	EN 60950 ;IEC 60947-4-3
Standards	

Insulation coordination (EN 50 178)

Rated voltage	300 V
Rated impulse withstand voltage	4.0 kV
Clearance and creepage distances for control side - load side	≥ 6.4 mm
Surge category	III
Pollution severity	2

Dimensions

Clamping range (rating- / min. / max.)	mm ²	16 / 1.5 / 16
Length x width x height	mm	98 x 22.5 x 116.1

Note

Ordering data

Connection system

Type	Qty.	Order No.
PSSR 24VDC/1PH AC 20A	1	8952110000

Note

Accessories

Note

Derating curve with moderate ventilation and 50% operational running time

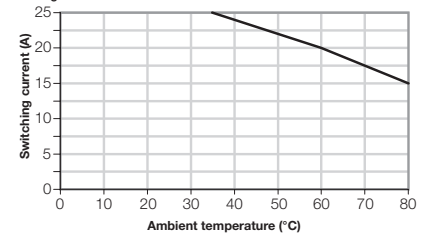

Derating curve without ventilation and in continual operation

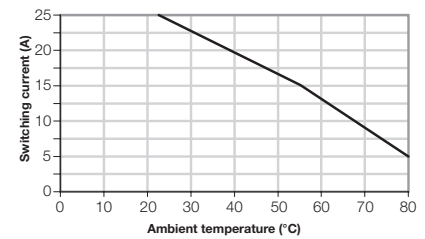

PSSR

- Load circuit 1-phase 12...275 VAC / 20 A
- Zero- voltage switching
- Ready-to-use: click on rail - wire up - ready
- Wear- & noiseless switching
- High peak current carrying capacity
I²t = 312 A²s (10 ms)

PSSR 230 V AC / 1 PH AC 20 A

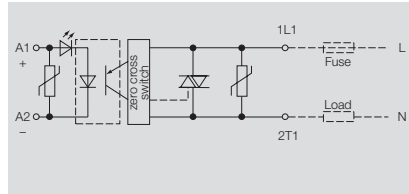

Technical data

Control side

- Rated voltage
- Power rating
- Making voltage
- Dropout voltage
- max. input frequency
- Status indicator
- Protective circuit

Load side

- Solid-state type
- Nominal switching voltage
- Nominal switching current
- Voltage drop at max. load
- Leakage current
- Short-circuit-proof/Protective circuit
- Switch-on delay/Switch-off delay
- Continuous current
- Pulse loading, max. current/Fuse
- Load category

General data

- Ambient temperature (operational)
- Storage temperature
- UL 94 flammability class
- Humidity
- Approvals
- Standards

Insulation coordination (EN 50 178)

- Rated voltage
- Rated impulse withstand voltage
- Clearance and creepage distances for control side - load side
- Surge category
- Pollution severity

Dimensions

- Clamping range (rating- / min. / max.) mm²
- Length x width x height mm

Note

Ordering data

Connection system

Note

Accessories

Note

110...240 V DC / 150...240 V AC
0.3...1.7 W
10 V DC / 150 V AC
1 V
10 Hz
LED green
RC element;varistor
Triac
12...275 V
20 A @ 55 °C
0.85 V
< 1 mA
no /RC element ;varistor
30 ms /30 ms
20 A
250 A (10 ms)/FERRAZ gRC 25 A 14x51 165 A ² s
AC 53: 5 A
-30 °C...+80 °C
-30 °C...+100 °C
40...85 % (indoor), no condensation
CE, cURus
EN 60950 ;IEC 60947-4-3
300 V
4.0 kV
≥ 6.4 mm
III
2

Derating curve with moderate ventilation and 50% operational running time

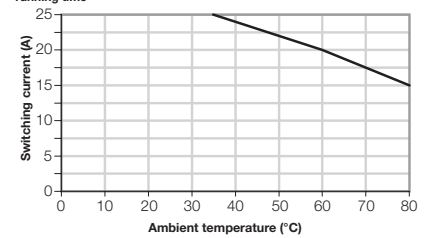

Derating curve without ventilation and in continual operation

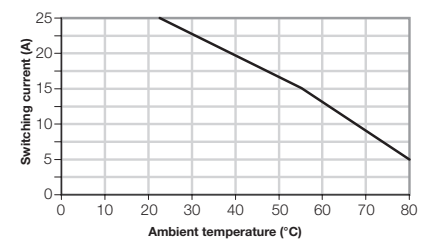

Type	Qty.	Order No.
PSSR 230VAC/1PH AC 20A	1	8952120000

Power solid-state relay

PSSR

- Load circuit 3-phase 24...520 VAC / 15 A
- Ready-to-use: click on rail - wire up - ready
- Wear- & noiseless switching
- High peak current carrying capacity
I_{pt} = 1500 A_s (10 ms)

PSSR 24 V DC / 3 PH AC 15 A

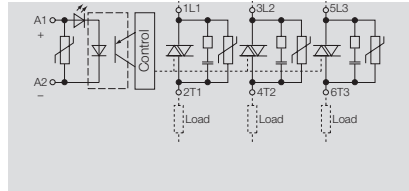

C

Technical data

Control side

Rated voltage
Power rating
Making voltage
Dropout voltage
max. input frequency
Status indicator
Protective circuit

8...30 V DC / 10...30 V AC
0.1...2 W
8 V DC / 10 V AC
4 V
10 Hz
LED green
RC element;varistor

Load side

Solid-state type
Nominal switching voltage
Nominal switching current
Voltage drop at max. load
Leakage current
Short-circuit-proof/Protective circuit
Switch-on delay/Switch-off delay
Continuous current
Pulse loading, max. current/Fuse
Load category

Back to back thyristor
24...520 V
15 A @ 55 °C
1.4 V
< 1 mA
no /RC element ;varistor
30 ms /30 ms
15 A
550 A (10 ms)/FERRAZ gRC 63 A 22x58 1353 A_s
AC 53: 3 x 12 A

General data

Ambient temperature (operational)
Storage temperature
UL 94 flammability class
Humidity
Approvals
Standards

-40 °C...+80 °C
-40 °C...+100 °C
40...85 % (indoor), no condensation
CE, cURus
EN 60950 ;IEC 60947-4-3

Insulation coordination (EN 50 178)

Rated voltage
Rated impulse withstand voltage
Clearance and creepage distances for control side - load side
Surge category
Pollution severity

300 V
4.0 kV
≥ 6.4 mm
III
2

Dimensions

Clamping range (rating- / min. / max.) mm²
Length x width x height mm

10 / 1.5 / 10
98 x 89.6 x 126.2

Note

Ordering data

Connection system

Type	Qty.	Order No.
PSSR 24VDC/3PH AC 20A	1	8952130000

Note

Accessories

Note

Derating curve with maximum ventilation

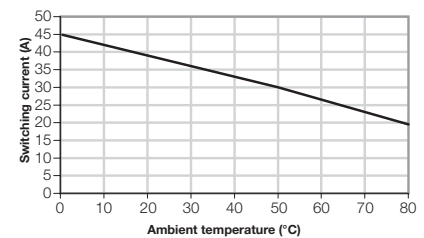

Derating curve with moderate ventilation and 50% operational running time

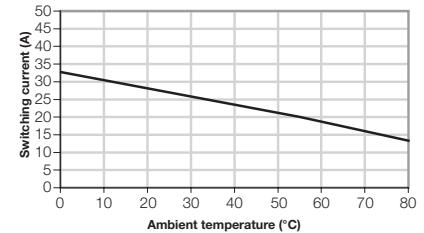

Derating curve without ventilation and in continual operation

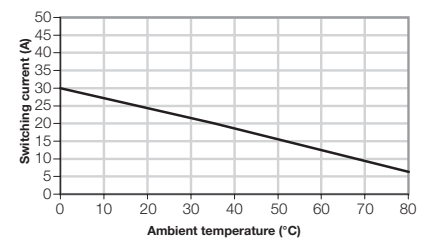

PSSR

- Load circuit 3-phase 24...520 VAC / 15 A
- Ready-to-use: click on rail - wire up - ready
- Wear- & noiseless switching
- High peak current carrying capacity
I_{pt} = 1500 A_s (10 ms)

PSSR 230 V AC / 3 PH AC 15 A

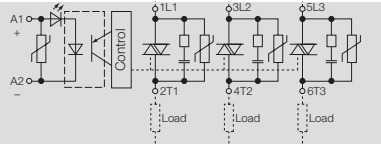

Technical data

Control side

Rated voltage
Power rating
Making voltage
Dropout voltage
max. input frequency
Status indicator
Protective circuit

90...240 V AC/DC
0.4...2.6 W
90 V AC/DC
15 V
10 Hz
LED green
RC element;varistor

Load side

Solid-state type
Nominal switching voltage
Nominal switching current
Voltage drop at max. load
Leakage current
Short-circuit-proof/Protective circuit
Switch-on delay/Switch-off delay
Continuous current
Pulse loading, max. current/Fuse
Load category

Back to back thyristor
24...520 V
15 A @ 55 °C
1.4 V
< 1 mA
no /RC element ;varistor
30 ms /30 ms
15 A
550 A (10 ms)/FERRAZ gRC 63 A 22x58 1353 A_s
AC 53: 3 x 12 A

General data

Ambient temperature (operational)
Storage temperature
UL 94 flammability class
Humidity
Approvals
Standards

-40 °C...+80 °C
-40 °C...+100 °C
40...85 % (indoor), no condensation
CE, cURus
EN 60950 ;IEC 60947-4-3

Insulation coordination (EN 50 178)

Rated voltage
Rated impulse withstand voltage
Clearance and creepage distances for control side - load side
Surge category
Pollution severity

300 V
4.0 kV
≥ 6.4 mm
III
2

Dimensions

Clamping range (rating- / min. / max.) mm²
Length x width x height mm

10 / 1.5 / 10
98 x 89.6 x 126.2

Note

Ordering data

Connection system

Type	Qty.	Order No.
PSSR 230VAC/3PH AC 20A	1	8952140000

Note

Accessories

Note

Derating curve with maximum ventilation

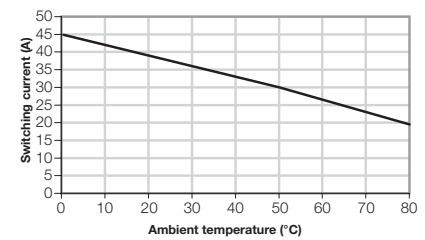

Derating curve with moderate ventilation and 50% operational running time

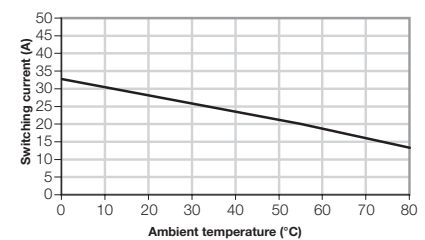

Derating curve without ventilation and in continual operation

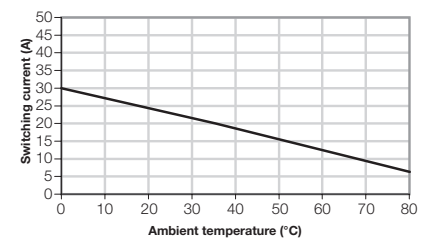

Installation timer relays

Electronic time relays from the BT product range offer ideal solutions for industrial applications.

The BT product range provides the following functions:

- Pick-up delay (BTR)
- Pulse emitter (BTTT)
- Multifunction (BTM)
- Multifunction (BTMF)
- Star-delta change-over

Time ranges and power supplies for timer relays

Using the central knob, you can select the functions of the modules precisely over either 4 or 8 time ranges.

The multi-voltage supply voltage range offers a wide bandwidth for industrial use (see table).

Time ranges

Display of time scale	Time ranges
0.1 s	0.1 to 1.2 s
1 s	1 to 12 s
0.1 min	0.1 to 1.2 min
1 min	1 to 12 min
0.1 h	0.1 to 1.2 h
1 h	1 to 12 h
10 h	10 to 120 h

Note:

If the rotary knob for time adjustment is set to "0", the output will be switched without delay.

Connection of the timer relay

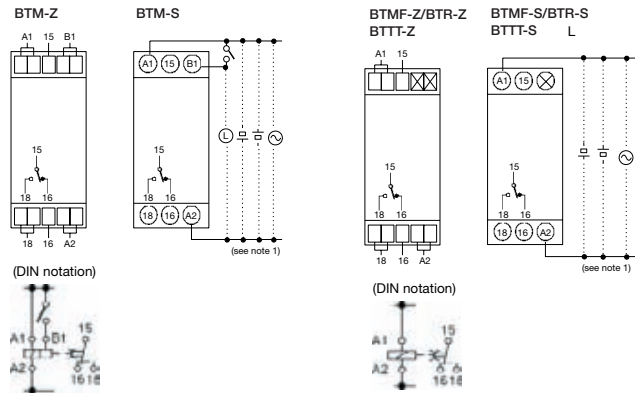

- Note:
1. Pole numbers are not necessary for DC voltage supply.
 2. The contact symbol of BTM is marked with  as it provides several operating modes and differs from the delayed contacts of conventional timer relays.

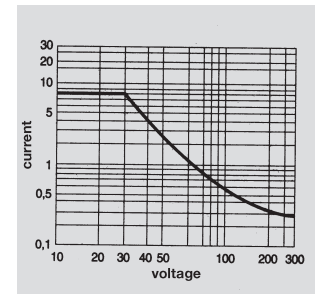
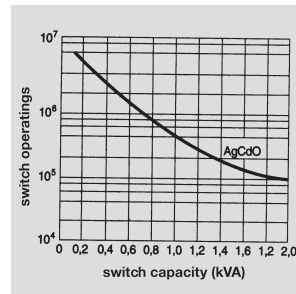

Choosing the time range

The time range is chosen by turning the rotary switch for the ON-time scale and OFF-time scale. The time scales are visible in the display to the left of the rotary switch in the following order: 0.1 s, 1 s, 0.1 m, 1 m, 0.1 h, 1 h.

Note:

The time scales “1 s” and “0.1 h” are given twice. Both adjustments represent the same time scale.

Locking/unlocking of selectors and time setting dial

The rotary switches for the ON/OFF time adjustment and the option selector for the time scale can be locked with the locking key.

This pen-style special tool is available separately. To lock either rotary switches or the option selector, simply insert the locking key into the keyhole bottom right of the rotary switch/option selector and turn it clockwise until the knob/switch is totally covered by the red cover. To unlock, simply turn the key in the opposite direction.

Connection system

The units offers the following connection technologies:

Screw connection

- 2 x 1.5 mm² with wire end ferrule
- 2 x 2.5 mm² without wire end ferrule

Tension clamp connection

- 2 x 1.5 mm² with wire end ferrule
- 2 x 2.5 mm² without wire end ferrule

Dimensions

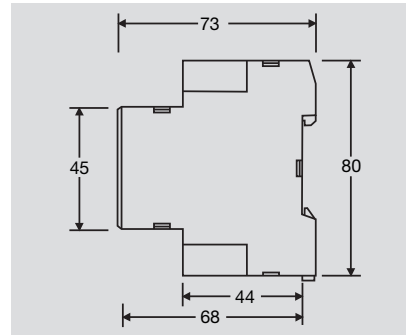

Screw connection

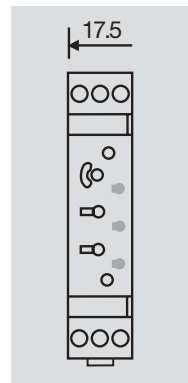

Tension clamp connection

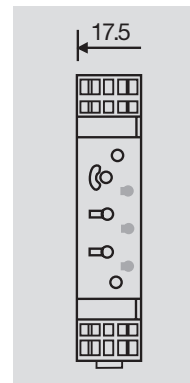

Timer relays – BT-SERIES

Installation timer relays

- Screw or tension clamp connection
- LED status indicator Input: voltage present
Output: output active
- Approvals **UL** 508 **CE** 22.2 Nr. 14
EN 61812-1 IEC 60664-1
IEC 60947-5-1 EN 61812-1
IEC 60664-1 IEC 60947-5-1
EN 55011 EN 50082-2



Type designation:

- B** = Building
T = Timer
R = Response Delay
TT = Two Times
M = Multifunction, 8 ranges
MF = Multifunction, 4 ranges
DS = Delta, Star
S = Screw
Z = Tension

Input		Contacts hard gold plated	
Rated voltage		24 ... 230 V AC, 50/60 Hz, 24 ... 48 V DC	
Voltage tolerance		85 ... 100 % of rated voltage	
Breaking voltage		Max. 2.4 V AC/V DC	
Power consumption per type	V AC	21 ... 33 VA at 230 V	
	V DC	0.6 ... 1.3 W at 24 V	
Reset time		Min. 0.1 s (BTDS: 0.5 s)	
Insulation			
Insulation resistance		100 M Ω min, at 500 V DC	
Insulation test voltage			
	between input and output, to enclosure	2000 V AC, 50/60 Hz, 1 min	
	between non-adjacent contacts	1000 V AC, 50/60 Hz, 1 min	
Ingress protection class		IP30, terminal block IP20	
Output			
Contact/contact material		1 change-over contact (BTDS 2 NOC) / AgNi 90/10	
Switch output		5A at 250 V AC, resistive load (cos φ = 1)	
Service life	mechanical min.	10 ⁷ switching cycles (no load, 1800/h)	
	electrical min.	10 ⁷ switching cycles (5A at 250 V AC, resistive load at 1800/h)	
Time range		0.10 s ... 120 h	
Repetition accuracy		± 1 %	
Other data			
Flammability class as per UL 94		V-2	
Ambient temperature/storage temperature		-10 ... +55 °C / -25 ... +65 °C (without condensation)	
Clamping range (nominal/min/max)	mm ²		
Length x width x height	mm	80.0 x 17.5 x 73.0	

Accessories

Designation

Locking and adjusting key

Type	Qty.	Order No.
BT Lock Pen	1	8659840000

Multifunction relay with control input (BTM)

Ordering data

Connection system	Type	Qty	Order No.
Screw connection	BTM-S	1	8647700000
Tension clamp	BTM-Z	1	8647710000

Functions

Function A – on-delay

Connect power supply (A1/A2). When the input signal (B1/A2) is applied, the on-delay lasting for the set time T starts. The output R (15/18) connects the load at the end of the set time. To reset, the power supply has to be switched off.

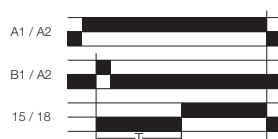

Function B – pulse emitter (starting at normal position)

Connect power supply (A1/A2). After applying the input signal (B1/A2), output R (15/18) switches the load synchronously and alternately between the normal and operated positions within the set time T. In this function, the cycle starts at the normal position.



Function B2 – pulse emitter (starting at operated position)

Connect power supply (A1/A2). After applying the input signal (B1/A2), output R (15/18) switches the load synchronously and alternately between the normal and operated positions within the set time T. In this function, the cycle starts at the operated position.



Function C – interval time-delay

Connect power supply (A1/A2). After applying the input signal (B1/A2), output R (15/18) connects the load for the set time T. Output R (15/18) switches the load off again at the end of time T. After switching off the input signal (B1/A2), output R (15/18) connects the load again for the set time T. Output R (15/18) switches the load off again at the end of time T.

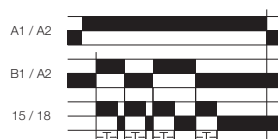

Function D – off-delay function

Connect power supply (A1/A2). After applying the input signal (B1/A2), output R (15/18) connects the load. The time delay T begins after the input signal (B1/A2) has been switched off. At the end of time T, output R (15/18) switches the load off again.

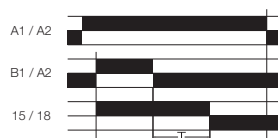

Function E – passing make function

Connect power supply (A1/A2). After applying the input signal (B1/A2), output R (15/18) connects the load immediately. At the end of the set delay time T, output R (15/18) switches the load off again.



Function G – on and off-delay function

Connect power supply (A1/A2). Time delay T begins after applying the input signal (B1/A2). At the end of this time, output R (15/18) connects the load (on-delayed). After the input signal (B1/A2) has been switched off again, the output switches the load off again after the set time (off-delayed).

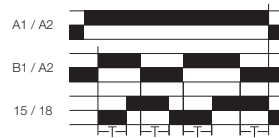

Function J – on-delay with pulse

Connect power supply (A1/A2). Time delay T begins after applying the input signal (B1/A2). At the end of this time, the output R (15/18) connects the load for 1 second.

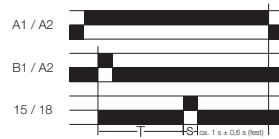

C

Timer relays – BT-SERIES

Multi-function relay without control input (BTMF)

Ordering data

Connection system	Type	Qty	Order No.
Screw connection	BTMF-S	1	8647680000
Tension clamp	BTMF-Z	1	8647690000

Timer relay (BTR)

Ordering data

Connection system	Type	Qty	Order No.
Screw connection	BTR-S	1	8647720000
Tension clamp	BTR-Z	1	8647730000

C

Functions

Function A – on-delay function

When the input signal (A1/A2) is applied, the on-delay lasting for the set time T starts. The output R (15/18) connects the load at the end of the set time. To reset, the power supply has to be switched off.

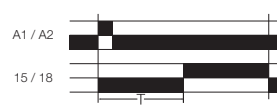

Functions

Function A – on-delay

When the power supply is connected (A1/A2), the on-delay lasting for the set time T starts. The output R (15/18) connects the load at the end of the set time.

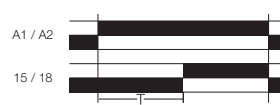

Function B2 – pulse emitter (starting at operated condition)

After applying the input signal (A1/A2), output R (15/18) switches the load synchronously and alternately between the normal and operated positions within the set time T. In this function, the cycle starts at the operated position.

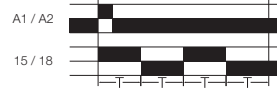

Function E – passing make function

After applying the input signal (A1/A2), output R (15/18) connects the load immediately. At the end of the set delay time T, output R (15/18) switches the load off again.



Function J – on-delay with pulse

Time delay T begins after applying the input signal (A1/A2). At the end of this time, the output R (15/18) connects the load for 1 second.



Timer relay (BTTT)

Timer relay (BTDS)

Ordering data

Connection system	Type	Qty	Order No.
Screw connection	BTTT-S	1	8647740000
Tension clamp	BTTT-Z	1	8647750000

Ordering data

Connection system	Type	Qty	Order No.
Screw connection	BTDS-S	1	8647660000
Tension clamp	BTDS-Z	1	8647670000

Functions

Function BTTT – pulse emitter

When the power supply is connected (A1/A2), the repeat cycle begins with two independently adjustable times. The standard setting is to start at the normal position. A bridge between connections A1 and A2 allows the module to start at the operated position.

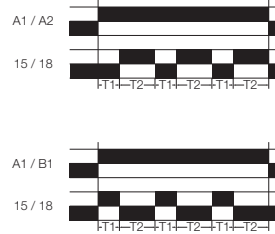

Functions

Star-delta changeover

After connecting the power supply, output R1 (17/18) connects immediately. At the end of time T1, output R1 (17/18) switches off and time T2 starts. At the end of time T2, output R2 (27/28) connects. After switching off the power supply, output R2 (27/28) switches off.

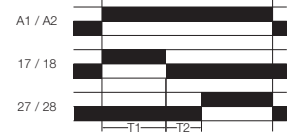

Timer relays - DK-SERIES

Mini-coupler DKZ

- Components for lengthening short pulses for the PLC
- Fixed switch-on/switch-off delay
- Low input power
- Screw clamp connection system
- Plug-in cross-connection
- 6 mm wide
- For mounting on TS 35

24 V DC 50 ms

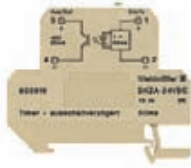

24 V DC 150 ms



24 V UC 1 s



C

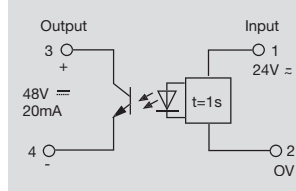
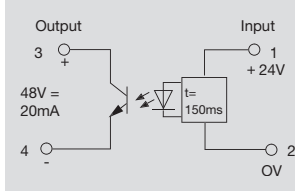
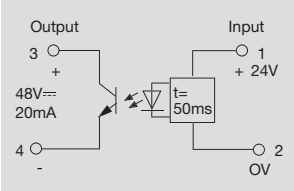

Technical data

Input

Rated voltage	24 V DC ±18 %
Rated current DC	6.7mA
Rated current AC	
Power rating	160 mW
Switch-on delay	
Switch-off delay	50 ms
min. impulse duration	2.0

Output

max. switching voltage DC	48 V
max. switching current	20 mA
max. switching frequency at rated load	20.0 Hz

Rated data

Ambient temperature (operational)	-25 °C...+50 °C
Storage temperature	-40 °C...+85 °C

Insulation coordination (EN 50178)

Rated voltage	300 V
Impulse withstand voltage	4 kV
Surge category	III
Pollution severity	2
Clearance and creepage distances for control side - load side	≥ 4 mm
Dielectric strength, Input/Output	4 kV

Dimensions

Clamping range (rating- / min. / max.)	mm²
Length x width x height	mm

Note

Screw connection

4 / 0.5 / 4
65 x 6 x 62

For mounting on TS 35 rail

Ordering data

Connection system	Screw connection
-------------------	------------------

Note

Accessories

Note	End plate AP DK4 0687560000
------	--------------------------------

Input

Rated voltage	24 V DC ±18 %
Rated current DC	6.7 mA
Rated current AC	
Power rating	160 mW
Switch-on delay	
Switch-off delay	150 ms
min. impulse duration	2.5

Output

max. switching voltage DC	48 V
max. switching current	20 mA
max. switching frequency at rated load	20.0 Hz

Rated data

Ambient temperature (operational)	-25 °C...+50 °C
Storage temperature	-40 °C...+85 °C

Insulation coordination (EN 50178)

Rated voltage	300 V
Impulse withstand voltage	4 kV
Surge category	III
Pollution severity	2
Clearance and creepage distances for control side - load side	≥ 4 mm
Dielectric strength, Input/Output	4 kV

Screw connection

4 / 0.5 / 4
65 x 6 x 62

For mounting on TS 35 rail

Input

Rated voltage	24 V UC ±10 %
Rated current DC	5.1 mA
Rated current AC	6.1 mA
Power rating	130 mW / 150 mVA
Switch-on delay	
Switch-off delay	1s
min. impulse duration	max. 0.7 ms

Output

max. switching voltage DC	48 V
max. switching current	20 mA
max. switching frequency at rated load	0.9 Hz

Rated data

Ambient temperature (operational)	-25 °C...+50 °C
Storage temperature	-40 °C...+85 °C

Insulation coordination (EN 50178)

Rated voltage	300 V
Impulse withstand voltage	4 kV
Surge category	III
Pollution severity	2
Clearance and creepage distances for control side - load side	≥ 4 mm
Dielectric strength, Input/Output	4 kV

Screw connection

4 / 0.5 / 4
65 x 6 x 62

For mounting on TS 35 rail

Type	(Qty.=1)	Order No.
DKZA 35 24VDC 150MS		8022110000

Note

Note	End plate AP DK4 0687560000
------	--------------------------------

Type	(Qty.=1)	Order No.
DKZ 35 24VUC 1S		8008190000

Note

Note	End plate AP DK4 0687560000
------	--------------------------------

Mini-coupler DKZ

- Components for lengthening short pulses for the PLC
- Fixed switch-on/switch-off delay
- Low input power
- Screw clamp connection system
- Plug-in cross-connection
- 6 mm wide
- For mounting on TS 35

24 V DC 10-100 ms

24 V DC 0.1-1 s

24 V DC 1-100 s

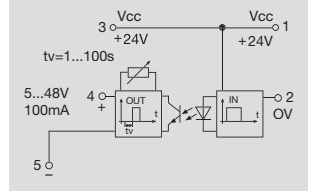
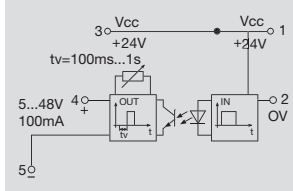
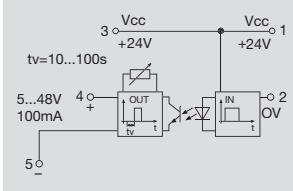
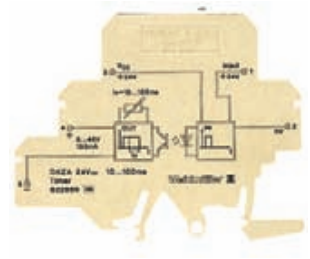
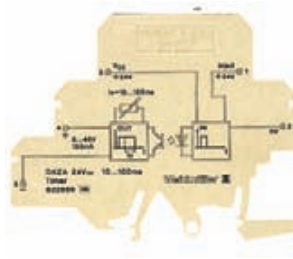
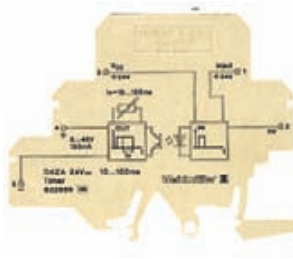

Technical data

Input

Rated voltage
 Rated current DC
 Power rating
 Switch-on delay

Output

max. switching voltage DC
 max. switching current

Rated data

Ambient temperature (operational)
 Storage temperature

Insulation coordination (EN 50178)

Rated voltage
 Impulse withstand voltage
 Surge category
 Pollution severity
 Clearance and creepage distances for control side - load side
 Dielectric strength, Input/Output

24 V DC $\pm 20\%$
 approx. 12 mA
 290 mW
 10...100 ms (adjustable)

48 V
 100 mA

-25 °C...+50 °C
 -40 °C...+85 °C

300 V
 6 kV
 IV
 2
 ≥ 5.5 mm
 4 kV

24 V DC $\pm 20\%$
 approx. 12 mA
 290 mW
 100 ms ... 1 s (adjustable)

48 V
 100 mA

-25 °C...+50 °C
 -40 °C...+85 °C

300 V
 6 kV
 IV
 2
 ≥ 5.5 mm
 4 kV

24 V DC $\pm 20\%$
 approx. 12 mA
 290 mW
 1 ... 100 s (adjustable)

48 V
 100 mA

-25 °C...+50 °C
 -40 °C...+85 °C

300 V
 6 kV
 IV
 2
 ≥ 5.5 mm
 4 kV

Dimensions

Clamping range (rating- / min. / max.) mm²
 Length x width x height mm

Note

Screw connection

4 / 0.5 / 4
 77 x 6 x 62

For mounting on TS 32/35 rails

Screw connection

4 / 0.5 / 4
 77 x 6 x 62

For mounting on TS 32/35 rails

Screw connection

4 / 0.5 / 4
 77 x 6 x 62

For mounting on TS 32/35 rails

Ordering data

Connection system

Screw connection

Note

Type (Qty.=1) Order No.
 DKZ DK5 24VDC 10-100MS **8228680000**

Type (Qty.=1) Order No.
 DKZ DK5 24VDC 0.1-1S **8243780000**

Type (Qty.=1) Order No.
 DKZ DK5 24VDC 1-100S **8019650000**

Accessories

Note

End plate
 AP DK5 8268870000

End plate
 AP DK5 8268870000

End plate
 AP DK5 8268870000

Timer relays - DK-SERIES

Mini-coupler DKZ

- Components for lengthening short pulses for the PLC
- Fixed switch-on/switch-off delay
- Low input power
- Screw clamp connection system
- Plug-in cross-connection
- 6 mm wide
- For mounting on TS 35

24 V DC 10-100 ms

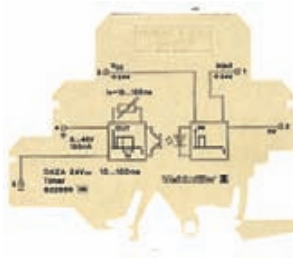

24 V DC 0.1-1 s

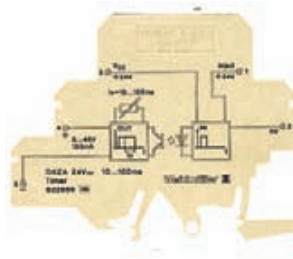

24 V DC 1-100 s

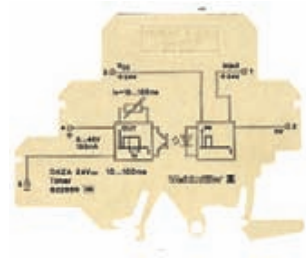

C

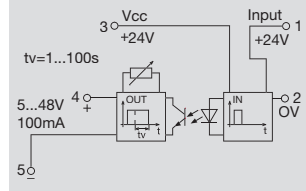
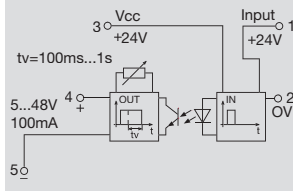
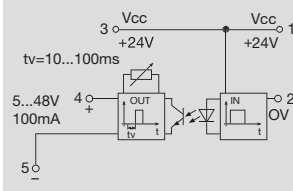

Technical data

Input

Rated voltage
Rated current DC
Power rating
Switch-off delay

Output

max. switching voltage DC
max. switching current

Rated data

Ambient temperature (operational)
Storage temperature

Insulation coordination (EN 50178)

Rated voltage
Impulse withstand voltage
Surge category
Pollution severity
Clearance and creepage distances for control side - load side
Dielectric strength, Input/Output

24 V DC $\pm 20\%$
approx. 11 mA

10 ... 100 ms (adjustable)

48 V
100 mA

-25 °C...+50 °C
-40 °C...+85 °C

300 V

6 kV

IV

2

≥ 5.5 mm

4 kV

24 V DC $\pm 20\%$
approx. 11 mA

100 ms ... 1 s (adjustable)

48 V
100 mA

-25 °C...+50 °C
-40 °C...+85 °C

300 V

6 kV

IV

2

≥ 5.5 mm

4 kV

24 V DC $\pm 20\%$
approx. 11 mA

1 ... 100 s (adjustable)

48 V
100 mA

-25 °C...+50 °C
-40 °C...+85 °C

300 V

6 kV

IV

2

≥ 5.5 mm

4 kV

Dimensions

Clamping range (rating- / min. / max.) mm²
Length x width x height mm

Note

Screw connection

4 / 0.5 / 4
77 x 6 x 62

For mounting on
TS 32/35 rails

Screw connection

4 / 0.5 / 4
77 x 6 x 62

For mounting on
TS 32/35 rails

Screw connection

4 / 0.5 / 4
77 x 6 x 62

For mounting on
TS 32/35 rails

Ordering data

Connection system

Screw connection

Note

Type	(Qty.=1)	Order No.
DKZA DK5 24VDC 10-100MS		8228690000

Type	(Qty.=1)	Order No.
DKZA DK5 24VDC 0.1-1S		8243770000

Type	(Qty.=1)	Order No.
DKZA DK5 24VDC 1-100S		8019630000

Accessories

Note

End plate
AP DK5 8268870000

End plate
AP DK5 8268870000

End plate
AP DK5 8268870000

Miniconditioner MCZ TO

- Components for lengthening short pulses for the PLC
- Fixed switch-off delay
- Low input power
- Tension clamp connection system
- Plug-in cross-connection
- 6 mm wide
- For mounting on TS 35

24 V DC 50 ms

24 V DC 150 ms

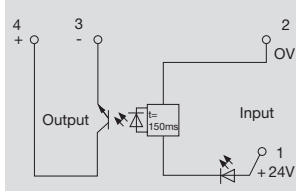
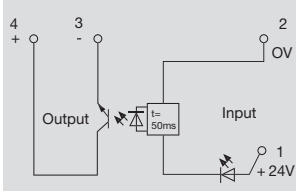

Technical data

Input

Rated voltage	24 V DC ±10%
Rated current DC	6.7mA +/-10%
Power rating	160 mW
Switch-off delay	50 ms
min. impulse duration	2.0 ms

Output

max. switching voltage DC	48 V
max. switching current	20 mA
max. switching frequency at rated load	20.0 Hz

Rated data

Operating temperature	-25 °C...+50 °C
Storage temperature	-40 °C...+85 °C

Insulation coordination (EN 50178)

Rated voltage	300 V
Impulse withstand voltage	6 kV
Surge category	III
Pollution severity	2
Clearance and creepage distances for control side - load side	≥ 5.5 mm
Dielectric strength, Input/Output	4 kV

Rated voltage	24 V DC ±10%
Rated current DC	6.7mA +/-10%
Power rating	160 mW
Switch-off delay	50 ms
min. impulse duration	2.0 ms

max. switching voltage DC	48 V
max. switching current	20 mA
max. switching frequency at rated load	20.0 Hz

Operating temperature	-25 °C...+50 °C
Storage temperature	-40 °C...+85 °C

Rated voltage	300 V
Impulse withstand voltage	6 kV
Surge category	III
Pollution severity	2
Clearance and creepage distances for control side - load side	≥ 5.5 mm
Dielectric strength, Input/Output	4 kV

Rated voltage	24 V DC ±10%
Rated current DC	6.7mA +/-10%
Power rating	160 mW
Switch-off delay	150 ms
min. impulse duration	2.5 ms

max. switching voltage DC	48 V
max. switching current	20 mA
max. switching frequency at rated load	5.0 Hz

Operating temperature	-25 °C...+50 °C
Storage temperature	-40 °C...+85 °C

Rated voltage	300 V
Impulse withstand voltage	6 kV
Surge category	III
Pollution severity	2
Clearance and creepage distances for control side - load side	≥ 5.5 mm
Dielectric strength, Input/Output	4 kV

Dimensions

Clamping range (rating- / min. / max.)	mm²
Length x width x height	mm

Note

Tension clamp c.

1.5 / 0.5 / 2.5
91 x 6 x 63.2

For mounting on TS 35

Tension clamp c.

1.5 / 0.5 / 2.5
91 x 6 x 63.2

For mounting on TS 35

Ordering data

Connection system	Tension clamp connection
--------------------------	--------------------------

Note

Type	(Qty.=1)	Order No.
MCZ TO 24VDC/50MS		8324590000

Type	(Qty.=1)	Order No.
MCZ TO 24VDC/150MS		8286410000

Accessories

Note	End plate AP MCZ 8389030000
-------------	--------------------------------

Note	End plate AP MCZ 8389030000
-------------	--------------------------------

