



GUARDIAN Electric Manufacturing

ISO 9001 / AS9100 Certified Company

Woodstock, IL 60098 Ph. (815)334-3600 Fax (815)337-0377

Or visit us at our website www.guardian-electric.com

Model TP12 x 19 Push-Type DC Tubular Solenoid

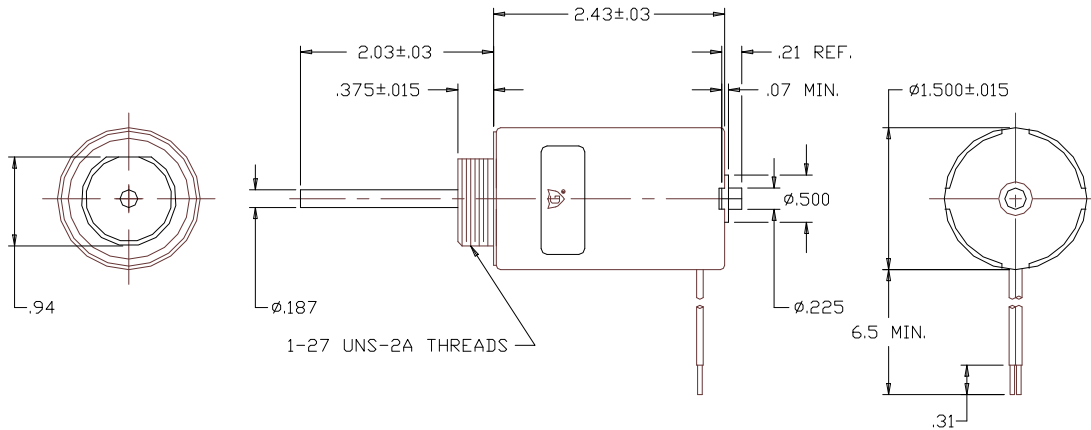

Solenoid shown energized and fully seated.

Supplied with mounting bracket, hex nut and lockwasher (not shown).

Spring kits are available (consult factory).

Total Weight: 14.2 oz.

Plunger Weight: 2.20 oz.

Model No.	Part No.	Duty Cycle	Voltage	Resistance (Ω)	Power (W)	Current
TP12x19-I-12	A422-064104-03	Intermittent	12VDC	5.6	27	2.15 A
TP12x19-C-12	A422-064104-04	Continuous	12VDC	17.5	8.6	685 mA
TP12x19-I-24	A422-064104-01	Intermittent	24VDC	22.1	27.4	1.09 A
TP12x19-C-24	A422-064104-02	Continuous	24VDC	68	8.9	353 mA

When ordering, please refer to Part No., as listed above.

Consult factory for custom configurations.

Stroke (in.)	Push Force (oz.)								Holding Force (oz.)
	0.050	0.125	0.250	0.375	0.500	0.625	0.750	1.000	-
Continuous Duty	80	48	24	16	14	12	8	6	143
Intermittent Duty	116	88	56	40	32	28	22	16	163

UL Recognition

Recognized under the  Component Recognition Program of Underwriters Laboratories, Inc.

Continuous Duty

100% 'On' Time

Intermittent Duty

25% 'On' Time, (100 Seconds 'On' Max. Followed By 300 Seconds 'Off' Min.)

RoHS

These parts comply with **RoHS** Directive 2002/95/EC