

**Possible to set and change the time with front digit switches easily during the power off.
Furthermore single unit has a time range of 0.01s to 9990hrs!!**



S Type
(with MODE switch)



G Type

FEATURES

1. Possible to set and change the time and the time range even when the power is off.
2. Selectable 8 different time ranges with front digit switches.
3. [QM4H-S Type]
It can select the mode with MODE switch.
T.D. MODE: Time delay 2C (2 Form C)
INST. MODE: Time delay 1C (1 Form C)
Instantaneous 1C (1 Form C)
[QM4H-G Type]
Reset and stop signal input enable to external control.

PRODUCT TYPES

| Product name | Time delay direction | Time range | Operating mode | Contact arrangement | Operating voltage | Part number |
|---------------------------|----------------------|--|---|---|--------------------|----------------|
| S Type QM4H digital timer | Addition | 0.01s/0.1s/1s/0.1min/ 1min/0.1h/1h/10h (8 time ranges) | Power ON delay | T.D. mode: Time delay 2C INST. mode: Time delay 1C and Instantaneous 1C (Use MODE switch on front) | 12 to 48 V AC/DC | QM4HS-U2C-48V |
| | | | | | 100 to 240 V AC/DC | QM4HS-U2C-240V |
| G Type QM4H digital timer | | | Power ON delay (with reset and stop terminals) | Time delay 1C | 12 to 48 V AC/DC | QM4HG-U1C-48V |
| | | | | | 100 to 240 V AC/DC | QM4HG-U1C-240V |

Note: Time delay directional subtraction types are also available by order

PART NAMES

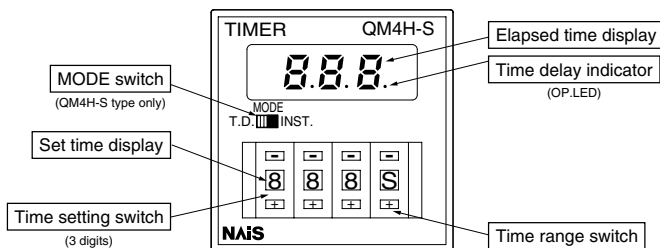

Protective construction:

QM4H: IP40
 with cover AQM4801: IP50
 with cover AQM4803: IP64

TIME RANGE SETTINGS

| | | | | | | | | |
|----------------------|----------------|---------------|------------|--------------------|-----------------|---------------|------------|--------------|
| Time range switch | | | | | | | | |
| Operating time range | 0.01s to 9.99s | 0.1s to 99.9s | 1s to 999s | 0.1min. to 99.9min | 1min. to 999min | 0.1h to 99.9h | 1h to 999h | 10h to 9990h |

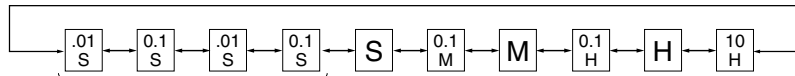

Note that there are two settings with the same range.

SPECIFICATIONS

| Item | | Type | QM4H-S | QM4H-G | | |
|-------------------------|---------------------------------------|--------------------|---|--|-------------------|--|
| Rating | Rated operating voltage | | 12 to 48 V AC/DC and 100 to 240 V AC/DC | | | |
| | Rated power consumption | 12 to 48 V AC/DC | During time delay | 12 V DC, 48 V DC: Max. 1.5W 12 V AC, 48 V AC: Max. 3.0 VA | During time delay | 12 V DC, 48 V DC: Max. 1.0W 12 V AC, 48 V AC: Max. 2.0 VA |
| | | | After time delay | 12 V DC, 48 V DC: Max. 2.5W 12 V AC, 48 V AC: Max. 5.0 VA | After time delay | 12 V DC, 48 V DC: Max. 1.5W 12 V AC, 48 V AC: Max. 3.5 VA |
| | | 100 to 240 V AC/DC | During time delay | 100 V DC, 240 V DC: Max. 1.5W 100 V AC, 240 V AC: Max. 3.0 VA | During time delay | 100 V DC, 240 V DC: Max. 1.0W 100 V AC, 240 V AC: Max. 2.5 VA |
| | | | After time delay | 100 V DC, 240 V DC: Max. 2.0W 100 V AC, 240 V AC: Max. 4.0 VA | After time delay | 100 V DC, 240 V DC: Max. 1.8W 100 V AC, 240 V AC: Max. 3.2 VA |
| | Rated frequency | | 50/60 Hz common (at AC) | | | |
| | Rated control capacity | | 5 A, 250V AC (resistive load) | | | |
| | Time range | | 0.01s to 9990h, Selection of 8 range: 0.01s/0.1s/1s/0.1min/1min/0.1h/1h/10h | | | |
| Operation mode | | Power ON delay | Power ON delay (with reset and stop terminals) | | | |
| Min. input signal width | | — | 20ms (Reset and Stop inputs)*4 | | | |
| Time accuracy*1 | Operating time fluctuation | | ±(0.01%+0.05s) in case of power on start | | | |
| | Temperature error | | ±(0.005%+0.03s) in case of input reset start*2 | | | |
| | Setting error | | Operating voltage: 85 to 110% V Temperature: -10 to +55°C +14 to 131°F (20°C 68°F) Stopped time: 0.1 sec to 1 hour | | | |
| | Voltage error | | | | | |
| Contact | Contact arrangement | | T.D. mode: Time delay 2C INST. mode: Time delay 1C and Instantaneous 1C (Use MODE switch on front) | Time delay 1C | | |
| | Contact material | | Silver alloy | | | |
| Life*3 | Mechanical (contact) | | Min. 10 ⁷ | | | |
| | Electrical (contact) | | Min. 10 ⁵ (at rated control vltage) | | | |
| Electrical | Allowable operating voltage range | | 85 to 110% of rated operating voltage | | | |
| | Breakdown voltage (Initial value) | | Between live and dead metal parts, between input and output, between contact sets, between contacts Min. 100 MΩ (at 500 V DC megger) | | | |
| | Insulation resistance (Initial value) | | Between live and dead metal parts: 2, 000 Vrms for 1 min Between input and output: 2, 000 Vrms for 1 min Between contact sets: 2, 000 Vrms for 1 min Between contacts: 1, 000 Vrms for 1 min | | | |
| | Reset time | | Max. 0.1s | | | |
| Mechanical | Vibration resistance | Functional | 10 to 55 Hz: 1 cycle/min. single amplitude of 0.25 mm .010 inch (10 min on 3 axes) | | | |
| | | Destructive | 10 to 55 Hz: 1 cycle/min. single amplitude of 0.375 mm .015 inch (1h on 3 axes) | | | |
| | Shock resistance | Functional | 98 m/s ² (4 times on 3 axes) | | | |
| | | Destructive | 980 m/s ² (5 times on 3 axes) | | | |
| Operating conditions | Ambient temperature | | -10°C to 55°C +14°F to +131°F | | | |
| | Ambient humidity | | Max. 85% RH (non-condensing) | | | |
| | Air pressure | | 860 to 1060 hPa | | | |
| Others | Mass (Weight) | | Approx. 130 g 4.59 oz | Approx. 120 g 4.23 oz | | |
| | Available standards | | UL, C-UL, CE | | | |
| | Operating display | | LED (red), During time delay: blinking, After time delay: OFF | | | |

Notes: 1. Unspecified measuring conditions are rated operating voltage (in case of DC type, ripple rate of 5% or less), ambient temp. 20°C 68°F, and stop time 1 second.

2. Reset start applies to QM4H-G type.

3. Excluding switches

4. Note that if the QM4H-G type is set to zero "0" and a STOP signal is input, output will begin when the power is turned on.

QM4H

DIMENSIONS

(units: mm inch)
Tolerance: ±1.0 .039

• S Type

• G Type

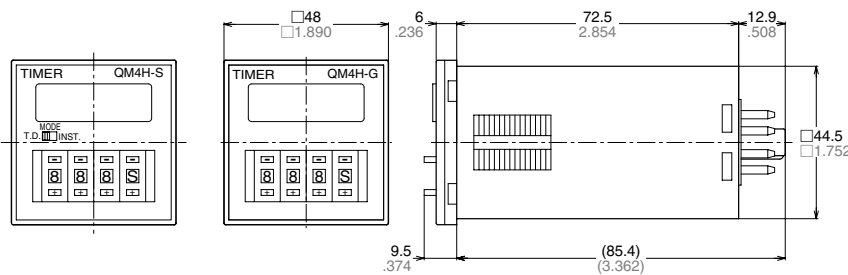

Panel cut-out dimensions

Panel Mounting Diagram

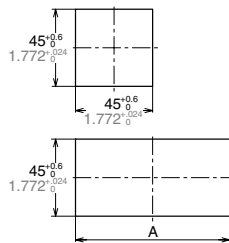

Dimensions A when n products are installed continuously:
 $A = (48 * n - 2.5 * 0.6)$ $A = (1.890 * n - .098 * 0.24)$

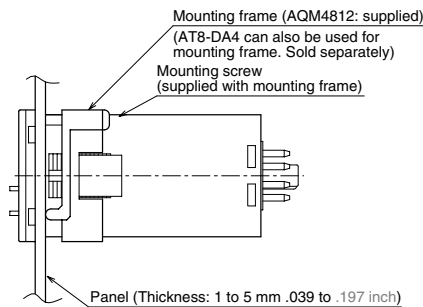

Terminal layouts and Wiring diagrams

• QM4H-S Type

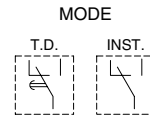
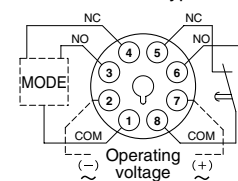

MODE
 T.D. mode: Time delay 2C
 INST mode:
 Time delay 1C and
 Instantaneous 1C
 *Use MODE switch on front

Notes:
 1. Operating voltage signs in parentheses () indicate the polarity of the DC type.
 2. is a time delay contact.
 is an instantaneous contact.

• QM4H-G Type

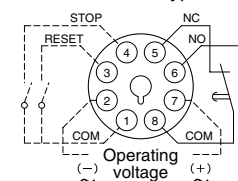

OPERATION MODE

• QM4H-S Type

1) T.D. mode

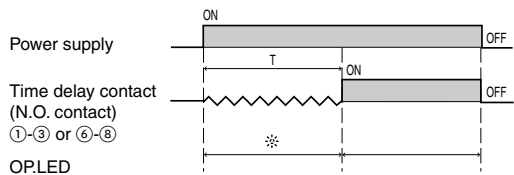

2) INST. mode

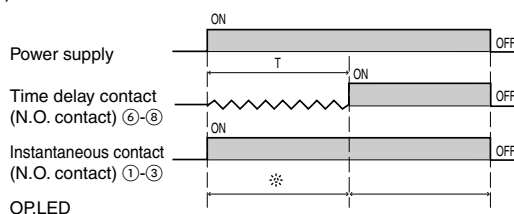

• QM4H-G Type

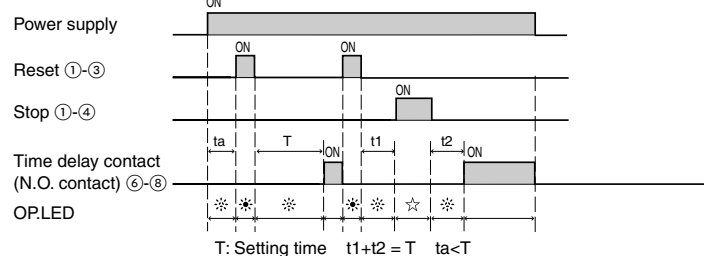

* Set the reset inputs ① to ③ and stop inputs ① to ④ to 20 ms or higher.
 * When shorting a signal, please set the inter-terminal resistance to 1 kΩ or less, and the inter-terminal residual voltage to 2 V or less. When releasing, please set the inter-terminal resistance to 100 kΩ or greater.

PRECAUTIONS IN USING THE QM4H

1. Avoid locations subject to flammable or corrosive gases, excessive dust, oil, vibrations, or excessive shocks.
2. Since the main-unit is made of polycarbonate resin, avoid contact with or use in environments containing methyl alcohol, benzene, thinners, and other organic solvents; and ammonia, caustic sodas, and other alkaline substances.
3. Power supply superimposed surge protector

Although a surge protector will withstand standard-waveform voltage with the values in the next table, anything above this will destroy the internal circuit. You

should therefore use a surge absorber.

| | |
|------------------|--------------------|
| 12 to 48 V AC/DC | 100 to 240 V AC/DC |
| 1,000 V | 6,000 V |

• Surge waveform
 $[\pm(1.2 \times 50) \mu\text{s uni-polar full wave voltage}]$

4. In order to maintain the characteristics, do not remove the timer case.
5. When installing the panel, use the supplied AQM4812 main-unit mounting frame. Note that the AT8-DA4 is also available for sale separately.
6. If you change the operating voltage, be sure not to allow leak current into the timer.

7. Avoid leaving the unit powered continuously. Leaving the unit powered up with output set to ON continuously for a long period of time (about 1 month or more) will wear out the electronic components. If you will be keeping it powered continuously, combine with a relay to create the circuit shown below:

