

### DIN Track Mounted, Standard 17.5-mm Width Timer Range

- A wide AC/DC power supply range (24 to 230 VAC/ 24 to 48 VDC) reduces the number of timer models kept in stock.
- Eight operating modes (H3DS-M) and four operating modes (H3DS-S) cover a wide range of applications.
- A wide time setting range of 0.10 s to 120 h.
- Two LEDs indicate power and relay status respectively.
- Smart Dial/Selector-locking Mechanism: Prevents the dials and selectors on the Timer's front panel from being inadvertently operated or being operated without authorization. The lock can only be unlocked and locked with an optional pen-type Lock Key.
- Screwless spring terminal type available.
- Sticker provided for easy timer identification and management.
- Terminal clamp left open when delivered (screw terminal type).
- Finger protection terminal block to meet VDE0106/P100.
- Enables easy sequence checks through instantaneous outputs for a zero set value at any time range.
- Conforms to EN61812-1 and IEC60664-1 (VDE0110) 4 kV/2.
- Conforms to EMC standards (EN50081-1 and EN50082-2).



### Ordering Information

Supply voltage	Control output	Input type	Operating mode (see note)	Model	
				Screw terminal type	Screwless spring terminal type
24 to 230 VAC (50/60Hz)/ 24 to 48 VDC	Contact output: SPDT  (time-limit output SPDT)	Voltage input	Eight multi-modes: A, B, B2, C, D, E, G, J	H3DS-ML	H3DS-MLC
		No-input available	Four multi-modes: A, B2, E, J	H3DS-SL	H3DS-SLC
			Single mode: A	H3DS-AL	H3DS-ALC

**Note:** The operating modes are as follows:

- A: ON-delay
- B: Flicker OFF start
- B2: Flicker ON start
- C: Signal ON/OFF-delay
- D: Signal OFF-delay
- E: Interval
- G: Signal ON/OFF-delay
- J: One shot

## ■ Model Number Legend

H3DS -     
           1    2    3

1. M: Multi-function type  
    S: Standard type  
    A: Single-function type
2. L: Smart lock mechanism
3. None: Screw terminal type  
    C: Screwless spring terminal type

## ■ Accessories (Order Separately)

Lock Key		Y92S-38
Mounting Track	50 cm (l) x 7.3 mm (t)	PFP-50N
	1 m (l) x 7.3 mm (t)	PFP-100N
	1 m (l) x 16 mm (t)	PFP-100N2
End Plate		PFP-M
Spacer		PEP-S

## Specifications

### ■ General

Item	H3DS-ML□	H3DS-SL□	H3DS-AL□
Operating mode	A: ON-delay (Signal or Power) B: Flicker OFF start (Signal or Power) B2: Flicker ON start (Signal or Power) C: Signal ON/OFF-delay D: Signal OFF-delay E: Interval (Signal or Power) G: Signal ON/OFF-delay J: One-shot (Signal or Power)	A: ON-delay B2: Flicker ON start E: Interval J: One-shot	A: ON-delay (fixed)
Input type	Voltage input	---	
Output type	Relay: SPDT		
External connections	Screw terminal, screwless spring terminal		
Terminal block	Screw terminal type: Clamps two 2.5-mm max. bar terminals without sleeves. Screwless spring terminal type: Clamps two 1.5-mm max. bar terminals without sleeves.		
Terminal screw tightening torque	0.98 N • m max.		
Mounting method	DIN track mounting (see note)		
Attachment	Nameplate label		
Approved standards	UL508, CSA 22.2 No.14 Conforms to EN61812-1, IEC60664-1 (VDE0110) 4 kV/2, VDE0106/P100 Conforms to IEC60947-5-1 (AC-13; 250 V 5 A/AC-14; 250 V 1 A/AC-15; 250 V 1 A/DC-13; 30 V 0.1 A/DC-14; 30 V 0.05 A) Conforms to EN50081-1 and EN50082-2		

**Note:** Can be mounted to DIN Track with a plate thickness of 1 to 2.5 mm.

### ■ Time Ranges

Time scale display	Time range
0.1 s	0.1 to 1.2 s
1 s	1 to 12 s
0.1 m	0.1 to 1.2 min
1 m	1 to 12 min
0.1 h	0.1 to 1.2 h
1 h	1 to 12 h
10 h	10 to 120 h

**Note:** When the time setting dial is set to "0" for any time scale, the output will operate instantaneously.

## ■ Ratings

<b>Rated supply voltage</b> (see notes 1 and 2)		24 to 230 VAC (50/60 Hz)/24 to 48 VDC
<b>Operating voltage range</b>		85% to 110% of rated supply voltage
<b>Power reset</b>		Minimum power-off time: 0.1 s
<b>Reset voltage</b>		2.4 VAC/DC max.
<b>Power consumption</b> (see note 3)	<b>H3DS-ML</b> □	AC: approx. 26.9 VA (1.8 W) at 230 VAC DC: approx. 0.6 W at 24 VDC
	<b>H3DS-SL</b> □	AC: approx. 26.5 VA (1.8 W) at 230 VAC DC: approx. 0.6 W at 24 VDC
	<b>H3DS-AL</b> □	AC: approx. 27.1 VA (1.8 W) at 230 VAC DC: approx. 0.6 W at 24 VDC
<b>Voltage input</b>		Max. permissible capacitance between inputs lines (terminals B1 and A2): 2,000 pF Load connectable in parallel with inputs (terminals B1 and A1). H-level: 20.4 to 253 VAC/20.4 to 52.8 VDC L-level: 0 to 2.4 VAC/DC
<b>Control output</b>		Contact output: 5 A at 250 VAC with resistive load ( $\cos\phi = 1$ ) 5 A at 30 VDC with resistive load ( $\cos\phi = 1$ )
<b>Ambient temperature</b>		Operating: -10°C to 55°C (with no icing) Storage: -25°C to 65°C (with no icing)
<b>Ambient humidity</b>		Operating: 35% to 85%

**Note:** 1. DC ripple rate: 20% max.

2. Since an inrush current of 0.4 A will occur when using the power supply voltage at 24 VDC, pay careful attention when turning on or off the power supply to the Timer with a solid-state output such as a sensor.
3. The power consumption is for mode A after the Timer counts the time-up time and for the AC input at 50 Hz. The power consumption of the H3DS-ML includes the input circuit with the B1 and A1 terminals short-circuited.

## ■ Characteristics

<b>Accuracy of operating time</b>	±1% max. of FS (±1% ±10 ms max. at 1.2-s range)
<b>Setting error</b>	±10% 50 ms max. of FS
<b>Signal input time</b>	50 ms min.
<b>Influence of voltage</b>	±0.5% max. of FS (±0.5% ±10 ms max. at 1.2-s range)
<b>Influence of temperature</b>	±2% max. of FS (±2% ±10 ms max. at 1.2-s range)
<b>Insulation resistance</b>	100 MΩ min. at 500 VDC
<b>Dielectric strength</b>	Between current-carrying metal parts and exposed non-current-carrying metal parts: 2,000 VAC for 1 min. Between control output terminals and operating circuit: 2,000 VAC for 1 min. Between contacts not located next to each other: 1,000 VAC for 1 min.
<b>Vibration resistance</b>	Malfunction: 0.5-mm single amplitude at 10 to 55 Hz Destruction: 0.75-mm single amplitude at 10 to 55 Hz
<b>Shock resistance</b>	Malfunction: 100 m/s <sup>2</sup> 3 times each in 6 directions Destruction: 1,000 m/s <sup>2</sup> 3 times each in 6 directions
<b>Impulse withstand voltage</b>	3 kV (between power terminals) 4.5 kV (between current-carrying metal parts and exposed non-current-carrying metal parts)
<b>Noise immunity</b>	Square-wave noise generated by noise simulator (pulse width: 100 ns/1 μs, 1-ns rise) ±1.5 kV
<b>Static immunity</b>	Malfunction: 4 kV Destruction: 8 kV
<b>Life expectancy</b>	Mechanical: 10 million operations min. (under no load at 1,800 operations/h) Electrical: 100,000 operations min. (5 A at 250 VAC, resistive load at 360 operations/h) (see note)
<b>EMC</b>	(EMI): EN50081-1 Emission Enclosure: EN55022 class B (equivalent to EN55011 class B) Emission AC Mains: EN55022 class B (equivalent to EN55011 class B) Harmonic Current: EN61000-3-2 Voltage Fluctuation and Flickering: EN61000-3-3 (EMS): EN50082-2 Immunity ESD: EN61000-4-2:4 kV contact discharge (level 2) 8 kV air discharge (level 3) Immunity RF-interference from AM Radio Waves: ENV50140: 10 V/m (80 MHz to 1 GHz) (level 3) Immunity RF-interference from Pulse-modulated Radio Waves: ENV50204: 10 V/m (900 ±5 MHz) (level 3) Immunity Conducted Disturbance: ENV50141: 10 V (0.15 to 80 MHz) (level 3) Immunity Burst: EN61000-4-4:2 kV power line (level 3) 2 kV I/O signal line (level 4)
<b>Case color</b>	Light gray (5Y7/1)
<b>Enclosure rating</b>	IP30 (Terminal block: IP20)
<b>Weight</b>	100 g

**Note:** For reference:

A maximum current of 0.15 A can be switched at 125 VDC (cosφ=1).

A maximum current of 0.1 A can be switched if L/R is 7 ms.

In both cases, a life of 100,000 operations can be expected.

The minimum applicable load is 10 mA at 5 VDC (failure level: P).

# Nomenclature

## H3DS-ML□/SL□

Output indicator (orange)  
(Lit while Timer output is ON.)  
Set time window

Time scale display window and  
selector (select one from 1 s,  
0.1 s, 1 h, 0.1 h, 10 h, 1 h, 1 m,  
and 0.1 m)

Operating mode display window  
and selector (select the mode from  
A, B, B2, C, D, E, G, and J for the  
H3DS-ML, from A, B2, E, and J for  
the H3DS-SL)

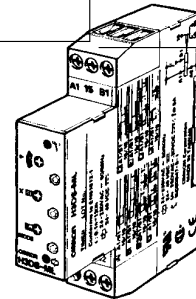
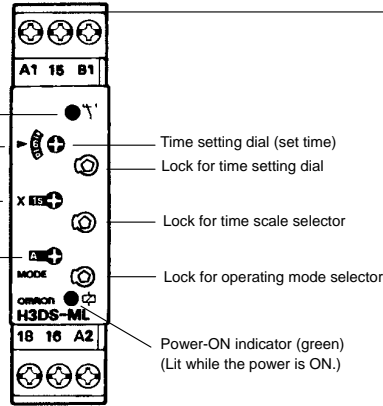

Attach the enclosed label  
here as a nameplate.  
(The label is attached to  
the Timer's DIN Track  
hook section at the time  
of shipment.)

## H3DS-AL□

Output indicator (orange)  
(Lit while Timer output is ON.)  
Set time window

Time scale display window and  
selector (select one from 1 s,  
0.1 s, 1 h, 0.1 h, 10 h, 1 h, 1 m,  
and 0.1 m)

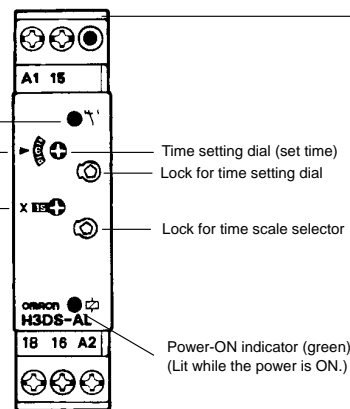

(Front View)

# Operation

## ■ Block Diagram

### H3DS-ML□

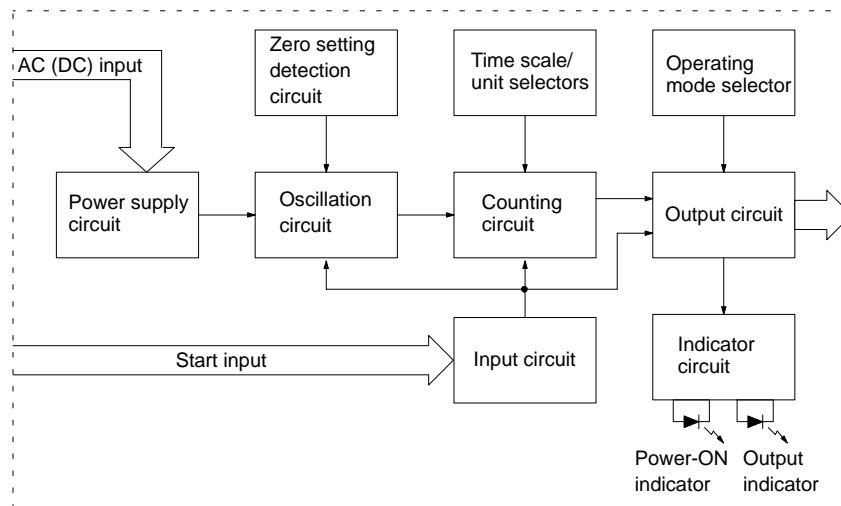

H3DS-SL□/-AL□

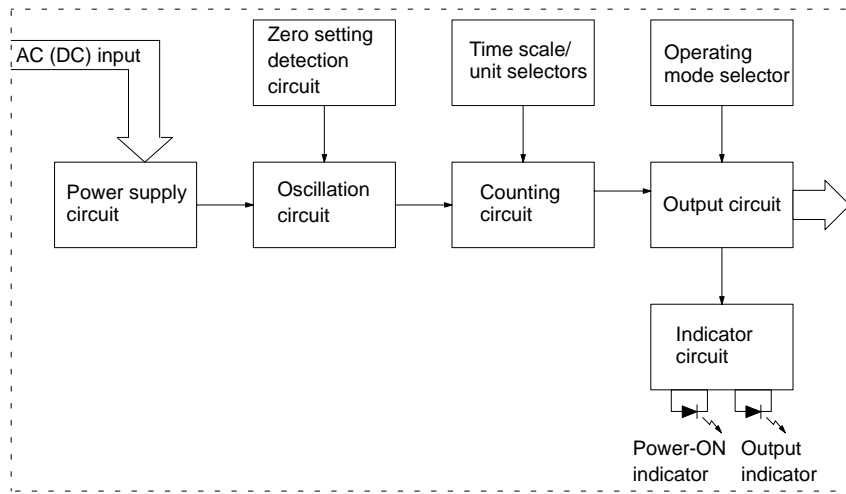

■ I/O Functions

Item		H3DS-ML□	H3DS-SL□/-AL□
Input	Start	Starts operation.	No input is available.
Output	Control output	Outputs are turned ON according to designated output mode when preset value is reached.	Outputs are turned ON according to designated output mode when preset value is reached.

■ Basic Operation

Setting of Selector

The selectors can be turned clockwise and counterclockwise to select the desired time scale, or operating mode.

Each selector has a snap mechanism that secures the selector at a given position. Set the selector at a position at which it is secured. Do not set it midway between two securing positions or a malfunction could result from improper setting.

Selection of Operating Mode (except for H3DS-AL)

The H3DS-ML/-SL can be set to any one of the operating modes A to J. Turn the operating mode selector with a screwdriver until the desired operating mode appears in the operating mode display window.

H3DS-ML (8 modes): A, B, B2, C, D, E, G, J (In order of appearance)  
 H3DS-SL (4 modes): A, E, B2, J, E, E, J, J (In order of appearance)

**Note:** Letters that appear more than once indicate exactly the same operating mode.

Selection of Time Scale

The time scale is selected by turning the time scale selector. The time scales will appear in the following order in the time scale display window on the left of the selector:

1 s, 0.1 s, 1 h, 0.1 h, 10 h, 1 h, 1 m, 0.1 m.

**Note:** The time scale "1h" appears twice. Both instances indicate exactly the same time scale.

Locking/Unlocking of Selectors and Time Setting Dial

The time setting dial, time scale selector, and operating mode selector can be locked using the Y92S-38 Lock Key, a special pen type tool that is sold separately. To lock the dial or selectors, insert the Lock Key in the keyhole to the lower right of the dial or selector and turn it clockwise until the dial or selector is completely covered with the red cover. To unlock, turn the Lock Key in the opposite direction.

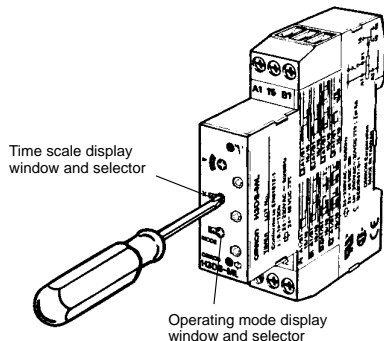
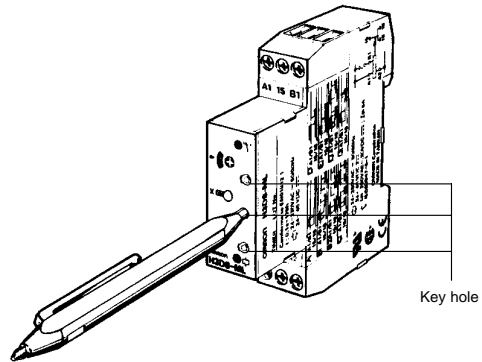

### ■ Timing Chart

- Note:** 1. The minimum power reset time is 0.1 s and the minimum signal input time is 0.05 s.  
 2. The letter "t" in the timing charts stands for the set time and "t-a" means that the period is less than the time set.

Operating mode	Timing chart	
<b>A: ON-delay</b>		<p><b>Basic operation</b></p> <p>* For power-on operation, impose voltage to the Start input. The Timer starts operating at the moment the power is turned on.                  ** Start input is invalid while the Timer is in operation.</p>
<b>B: Flicker OFF start</b>		<p><b>Basic operation</b></p> <p>* For power-on operation, impose voltage to the Start input. The Timer starts operating at the moment the power is turned on.                  ** Start input is invalid while the Timer is in operation.</p>
<b>B2: Flicker ON start</b>		<p><b>Basic operation</b></p> <p>* For power-on operation, impose voltage to the Start input. The Timer starts operating at the moment the power is turned on.                  ** Start input is invalid while the Timer is in operation.</p>
<b>C: Signal ON/OFF-delay</b>		<p><b>Basic operation</b></p> <p>* Start input is invalid while the Timer is in operation.</p>

**Note:** The start input of the H3DS-ML□ model is activated by applying a voltage to B1 and A2 terminals. The voltage can be applied by turning on the contact between B1 and A1 (Refer to *Terminal Arrangement*).

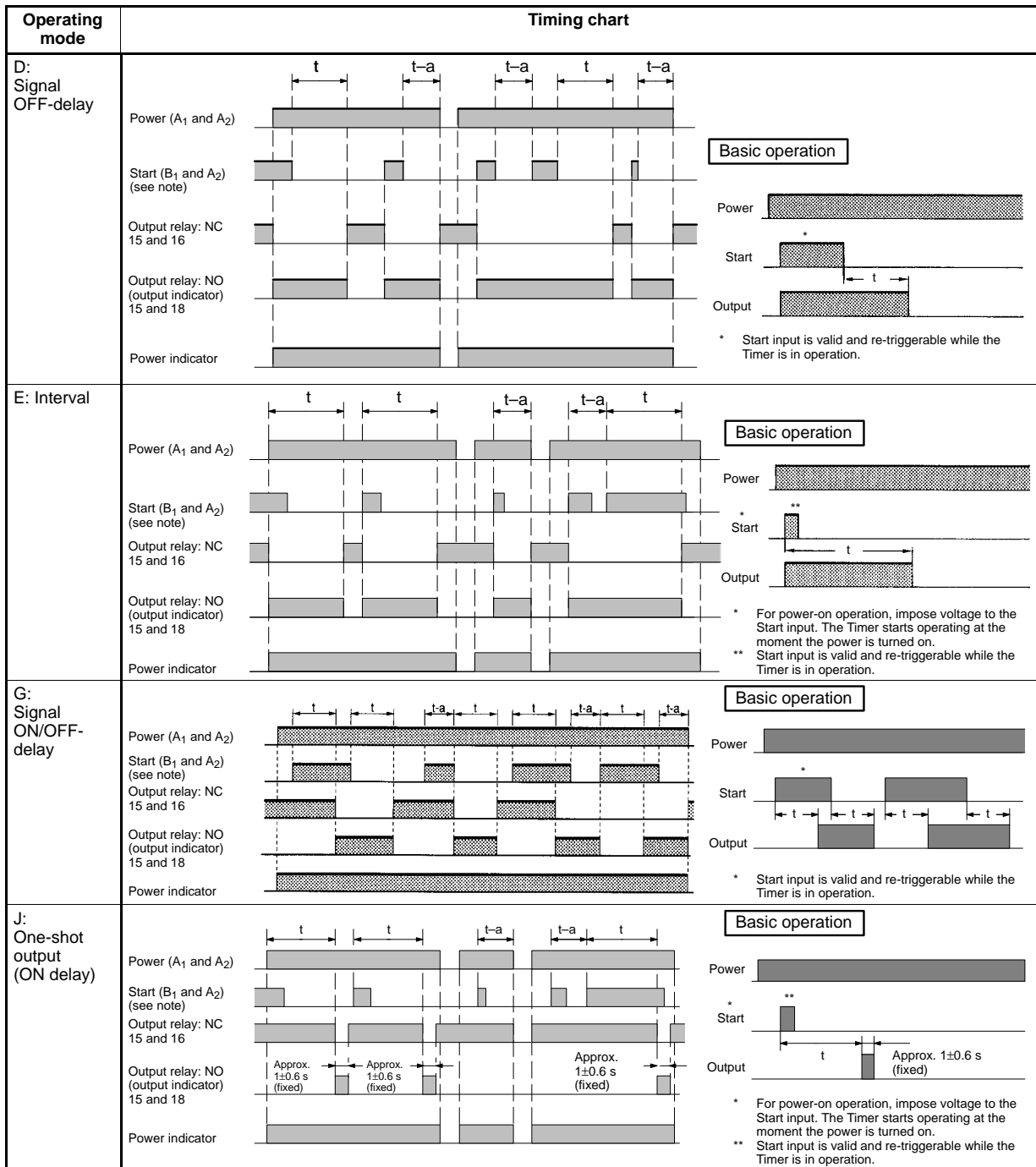

**Note:** The start input of the H3DS-ML□ model is activated by applying a voltage to B1 and A2 terminals. The voltage can be applied by turning on the contact between B1 and A1 (Refer to *Terminal Arrangement*).



# Dimensions

**Note:** All units are in millimeters unless otherwise indicated.

H3DS-ML□/-SL□/-AL□

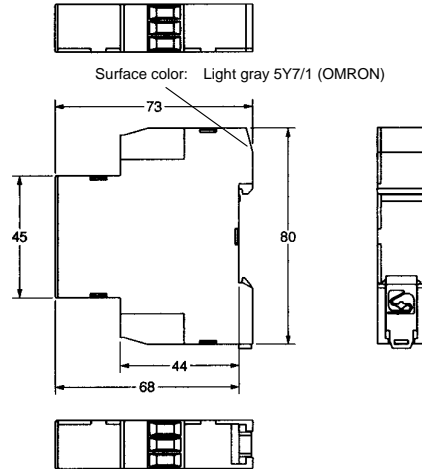
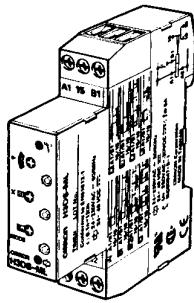

# Installation

## Terminal Arrangement

H3DS-ML□

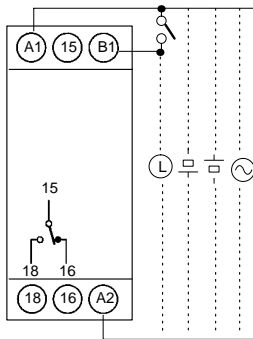

(see note 1)

H3DS-SL□/-AL□

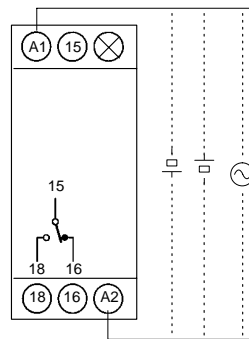

(see note 1)

**Note:** 1. DC supply voltage does not require the designation of polarity.

2. The contact symbol for the H3DS is indicated with  because it offers multiple operating modes and is different from the delayed contact for conventional timers.

### Input Connections

The inputs of the H3DS-ML□ are voltage (voltage imposition or open) inputs.

#### No-contact Input

(Connection to PNP output sensor.)

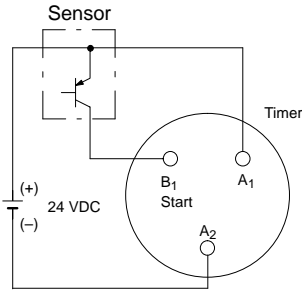

Operates with PNP transistor ON

#### No-contact Input

(Connection to NPN output sensor.)

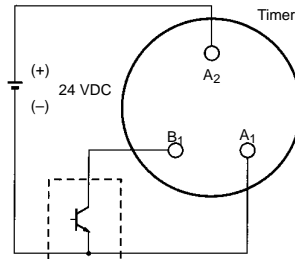

Operates with NPN transistor ON

#### Contact Input

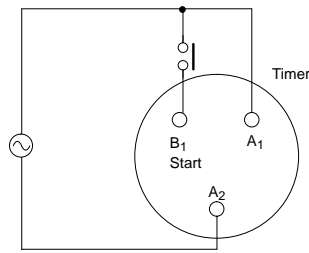

Operates with relay ON

#### Voltage Input Signal Levels

No-contact input	1. Transistor ON Residual voltage: 1 V max. (Voltage between terminals B <sub>1</sub> and A <sub>2</sub> must be more than the rated "H-level" voltage (20.4 VDC min.).)
	2. Transistor OFF Leakage current: 0.01 mA max. (Voltage between terminals B <sub>1</sub> and A <sub>2</sub> must be less than the rated "L-level" voltage (2.4 VDC max.).)
Contact input	Use contacts that can adequately switch 0.1 mA at each voltage to be imposed. (When the contacts are ON or OFF, voltage between terminals B <sub>1</sub> and A <sub>2</sub> must be within the following ranges: When contacts are ON: 20.4 to 253 VAC/20.4 to 52.8 VDC When contacts are OFF: 0 to 2.4 VAC/DC)

# Accessories (Order Separately)

**Note:** All units are in millimeters unless otherwise indicated.

## ■ Dimensions

### Lock Key Y92S-38

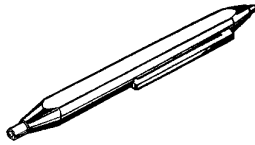

### Mounting Track PFP-100N, PFP-50N

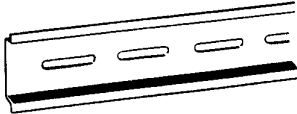

### PFP-100N2

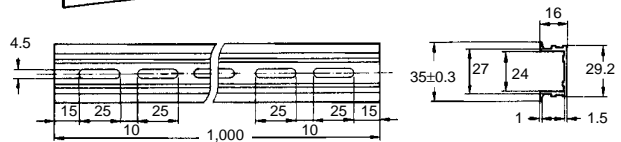
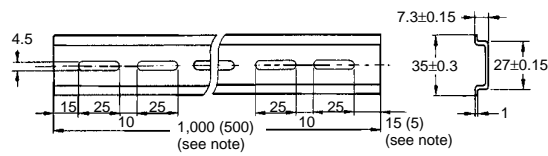

**Note:** The values shown in parentheses are for the PFP-50N.

### End Plate PFP-M

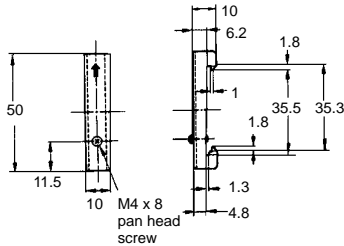
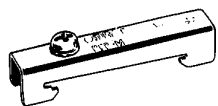

### Spacer PFP-S

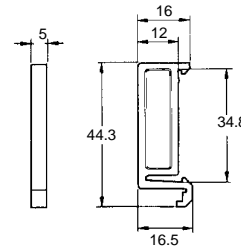
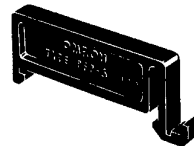

# Precautions

## ■ Changing of Setting

**NOTICE:** Do not change the time scale or operating mode, while the Timer is in operation or malfunction could result.

## ■ Power Supplies

The H3DS Series is provided with a transformerless power supply system. An electric shock may be received if the input terminal or the output type selector switch is touched while power is being supplied.

Use the bar terminal for wiring the H3DS. Using a stranded-wire terminal may cause a short-circuit due to a stray wire entering into the Timer.

Both AC and DC power supplies can be connected to the power input terminals without regarding polarity.

With the H3DS only, a DC power supply must be connected to the power input terminals as designated according to the polarity of the terminals.

A DC power supply can be connected if its ripple factor is 20% or less and the mean voltage is within the rated operating voltage range of the Timer.

Make sure that the voltage is applied within the specified range, otherwise the internal elements of the Timer may be damaged.

Connect the power supply voltage through a relay or switch in such a way that the voltage reaches a fixed value at once or the Timer may not be reset or a timer error could result.

For the power supply of an input device of the H3DS-ML□, use an isolating transformer, of which the primary and secondary windings are mutually isolated and the secondary winding is not grounded.

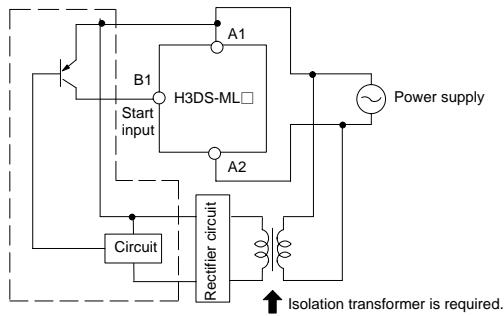

## ■ Installation

If the load current is continuously being supplied to the Timer for a long period of time, be sure to provide the mounting clearance as shown in the figure below. If used under the conditions other than those specified below, the life of internal components may be shortened due to an excessive rise in the internal temperature.

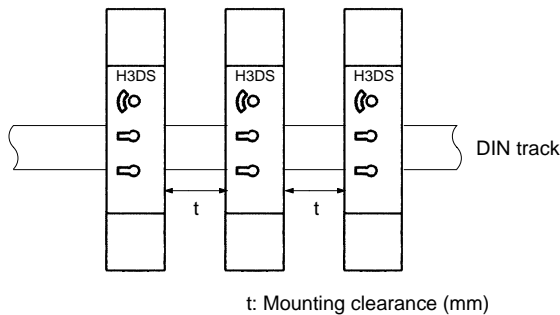

## Switching Current vs. Ambient Temperature (When Mounting Two or More H3DS Units Side-by-Side)

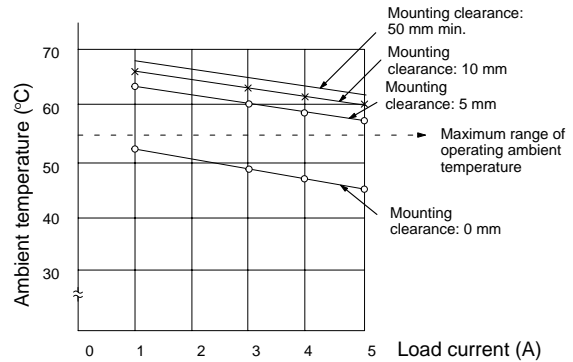

(Measurement Condition: Input voltage of 230 VAC)

## ■ Input/Output

### Relationship between Input and Power Supply Circuits (H3DS-ML□)

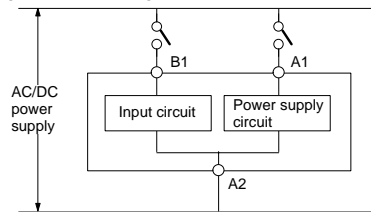

Since the input circuit and the power supply circuit are configured independently, the input circuit can be turned on or off irrespective of the on/off state of the power supply.

It must be noted that a voltage equivalent to the power supply voltage is applied to the input circuit.

When connecting a relay or a transistor as an external signal input device, pay attention to the following points to prevent short-circuiting due to a sneak current to the transformerless power supply.

If a relay or transistor is connected to two or more Timers, the input terminals of those Timers must be wired properly so that they will not be different in phase or the terminals will be short-circuited to one another (refer to the figures below).

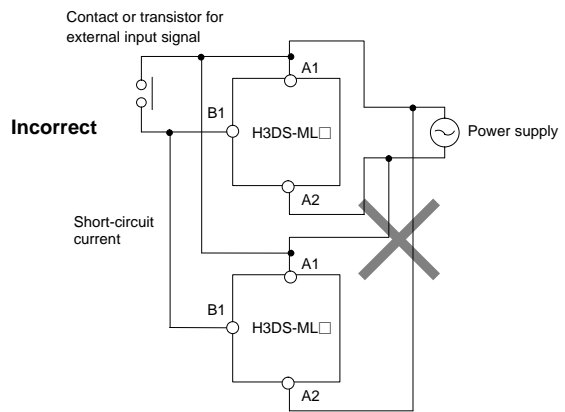

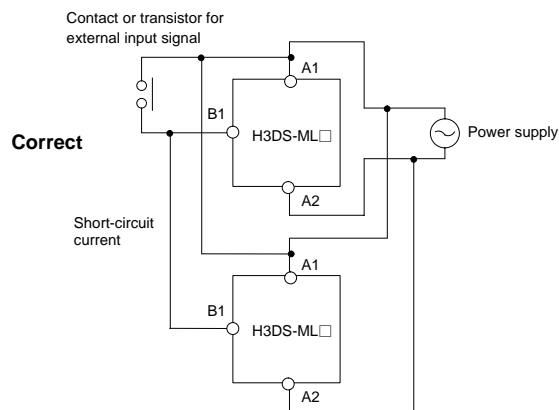

The H3DS Series is provided with a transformerless power supply system.

### Input Wires

The input wires must be as short as possible. If the floating capacity of wires exceeds 2,000 pF (approx. 17 m for cables with 120 pF/m), the operation will be affected. Pay particular attention when using shielded cables.

### ■ Precautions for EN61812-1 Conformance

The H3DS as a built-in timer conforms to EN61812-1 provided that the following conditions are satisfied:

The output section of the H3DS is provided only with basic isolation. To ensure reinforced isolation required by the EN61812-1, provide supplementary basic isolation on the load side connected to the output.

The H3DS itself is designed according to the following:

- Overvoltage category III
- Pollution degree 2

On the above basis:

Operation parts on the front and bottom: Reinforced isolation

- With clearance of 5.5 mm and creepage distance of 5.5 mm at 230 VAC

Output: Basic isolation

- With clearance of 3 mm and creepage distance of 3 mm at 230 VAC

### ■ Environment

When using the Timer in an area with excess electronic noise, separate the Timer, wiring, and the equipment which generates the input signals as far as possible from the noise sources. It is also recommended to shield the input signal wiring to prevent electronic interference.

Organic solvents (such as paint thinner), as well as very acidic or basic solutions can damage the outer casing of the Timer.

Do not use the Timer in places where it is exposed to dust, corrosive gas, or direct sunlight.

When storing the Timer, make sure that the ambient temperature and humidity are within the rated values. Leave the Timer at room temperature for at least three hours before using the Timer if it has been stored at an ambient temperature of  $-10^{\circ}\text{C}$  or below.

### ■ Others

If the Timer is mounted on a control board, dismantle the Timer from the control board or short-circuit the circuitry of the power board before carrying out a voltage withstand test between the electric circuitry and non current-carrying metal part of the Timer, in order to prevent the internal circuitry of the Timer from damage.

**ALL DIMENSIONS SHOWN ARE IN MILLIMETERS.**

To convert millimeters into inches, multiply by 0.03937. To convert grams into ounces, multiply by 0.03527.

Cat. No. L098-E1-1A **In the interest of product improvement, specifications are subject to change without notice.**

## OMRON Corporation

Industrial Automation Company

Measuring and Supervisory Controls Department  
28th Fl., Crystal Tower Bldg.,  
1-2-27, Shiromi, Chuo-ku,  
Osaka 540-6028 Japan  
Tel: (81)6-6949-6035/Fax: (81)6-6949-6069

Printed in Japan  
0600-3M (0200) (O)