

Features

- Slightly Larger than One Cubic Inch
- See-Thru Plastic Cover
- Plug-In or Solder Terminal
- PC Board Mount (P-suffix)
- Indicator Lamp Types (N-suffix)
- Hermetically Sealed, Metal Enclosure Types (H-suffix)
- Push-to-Test Button Types (B-suffix)
- Bifurcated Contact Type (T-suffix)
- High Reliability, 50 Million Operations

AC OPERATED						
NTE Type No.	Nom. Voltage	Contact Arr.	Coil Res. Ohms (Typ)	Nom. Power	Max. Contact Cur. @ 28VDC or 120VAC	Diag No.
R12-11A5-12	12VAC	DPDT	—	1.2VA	5A	D8a
R12-11A5-24	24VAC	DPDT	—	1.2VA	5A	D8a
R12-11A5-120	115VAC	DPDT	—	1.2VA	5A	D8a
R12-11A5-240	240VAC	DPDT	—	1.2VA	5A	D8a
R12-14A5-12	12VAC	3PDT	—	1.2VA	5A	D32b
R12-14A5-24	24VAC	3PDT	—	1.2VA	5A	D32b
R12-14A5-120	120VAC	3PDT	—	1.2VA	5A	D32b
R12-17A5-24H	24VAC	4PDT	—	1.2VA	5A	D22c
R12-17A5-24N	24VAC	4PDT	—	1.2VA	5A	D8c
R12-17A5-120H	115VAC	4PDT	—	1.2VA	5A	D22c
R12-17A5-120N	120VAC	4PDT	—	1.2VA	5A	D8c
R12-17A3-12	12VAC	4PDT	—	1.2VA	5A	D8c
R12-17A3-12B	12VAC	4PDT	—	1.2VA	3A	D8c
R12-17A3-12P	12VAC	4PDT	—	1.2VA	3A	D9c
R12-17A3-12T	12VAC	4PDT	—	1.2VA	1A	D8c
R12-17A3-24	24VAC	4PDT	—	1.2VA	5A	D8c
R12-17A3-24B	24VAC	4PDT	—	1.2VA	3A	D8c
R12-17A3-24P	24VAC	4PDT	—	1.2VA	5A	D9c
R12-17A3-24T	24VAC	4PDT	—	1.2VA	1A	D8c
R12-17A3-120	120VAC	4PDT	—	1.2VA	5A	D8c
R12-17A3-120B	120VAC	4PDT	—	1.2VA	5A	D8c
R12-17A3-120P	120VAC	4PDT	—	1.2VA	5A	D9c
R12-17A3-120T	120VAC	4PDT	—	1.2VA	1A	D8c
R12-17A3-240	240VAC	4PDT	—	1.2VA	3A	D8c

DC OPERATED						
NTE Type No.	Nom. Voltage	Contact Arr.	Coil Res. Ohms (Typ)	Nom. Power	Max. Contact Cur. @ 28VDC or 120VAC	Diag No.
R12-11D5-12	12VDC	DPDT	160	0.9W	5A	D8a
R12-11D5-24	24VDC	DPDT	650	0.9W	5A	D8a
R12-14D5-6	6VDC	3PDT	40	0.9W	5A	D32b
R12-14D5-12	12VDC	3PDT	160	0.9W	5A	D32b
R12-14D5-24	24VDC	3PDT	650	0.9W	5A	D32b
R12-17D5-12H	12VDC	4PDT	160	0.9W	5A	D22c
R12-17D5-12N	12VDC	4PDT	160	0.9W	5A	D8c
R12-17D5-24H	24VDC	4PDT	650	0.9W	5A	D22c
R12-17D5-24N	24VDC	4PDT	650	0.9W	5A	D8c
R12-17D3-6	6VDC	4PDT	40	0.9W	5A	D8c
R12-17D3-6P	6VDC	4PDT	40	0.9W	5A	D9c
R12-17D3-12	12VDC	4PDT	160	0.9W	3A	D8c
R12-17D3-12B	12VDC	4PDT	160	0.9W	3A	D8c
R12-17D3-12P	12VDC	4PDT	160	0.9W	3A	D9c
R12-17D3-12T	12VDC	4PDT	160	0.9W	1A	D8c
R12-17D3-24	24VDC	4PDT	650	0.9W	5A	D8c
R12-17D3-24B	24VDC	4PDT	650	0.9W	3A	D8c
R12-17D3-24P	24VDC	4PDT	650	0.9W	5A	D9c
R12-17D3-24T	24VDC	4PDT	650	0.9W	1A	D8c
R12-17D3-48	48VDC	4PDT	2600	0.9W	3A	D8c
R12-17D3-110	110VDC	4PDT	11000	0.9W	3A	D8c

Note 1. R12 Series hermetically sealed relays (H-suffix) are UL recognized for Class 1, Division 2 (Hazardous locations).

ACCESSORIES		
MOUNTING STYLES	DESCRIPTION	NTE TYPE NO.
SURFACE MOUNT	14-PIN BLADE	R95-106A
SURFACE MOUNT	8-PIN BLADE	R95-150
PANEL MOUNT	14-PIN BLADE	R95-122
PANEL MOUNT	11-PIN BLADE	RLY9151
PANEL MOUNT	8-PIN BLADE	R95-148
PC MOUNT	14-PIN BLADE	R95-107
PC MOUNT	11-PIN BLADE	RLY9152
PC MOUNT	8-PIN BLADE	R95-149
DIN RAIL MOUNT	14-PIN BLADE	R95-117
DIN RAIL MOUNT	11-PIN BLADE	RLY9153

R12 Series



General Purpose, 1 Amp, 3 Amp & 5 Amp, DPDT, 3PDT & 4PDT AC & DC Relays.



Electrical Specifications

Contact

Contact Rating: 5 Amp @ 240 VAC/28 VDC,
3 Amp @ 240 VAC/28 VDC
1 Amp @ 240 VAC/28 VDC

Contact Material: AgNi / AgSnO Alloy

Silver ^w/Gold Flashing (T-type ONLY)

Contact Resistance: 100 milliohms max. (at 6 VDC, 1 Amp)

Coil

Coil Voltages: See Chart

Pick-up Voltage: 80% of nominal or less for AC
75% of nominal or less for DC

Resistance: See chart

Min Sensitivity: 0.5 Watts DC .75 volt Amps (60Hz)

Duty Cycle: Continuous

Operational Characteristics

Timing Values Operate Time: 25 ms or less } at nominal
Release Time: 25 ms or less } coil voltage

Insulation Characteristics

Dielectric Strength

Contact To Coil: 1500 VRMS (50/60 Hz)

Across Open Contacts: 1000 VRMS (50/60 Hz)

Coil to Frame: 1500 VRMS (50/60 Hz)

Insulation Resistance: 100 megohms Min. @ 500 VDC

Environmental Characteristics

Operating: -30°C to +55°C

Weight

Std: 1 1/2 ozs (45 grams)—approx

D8

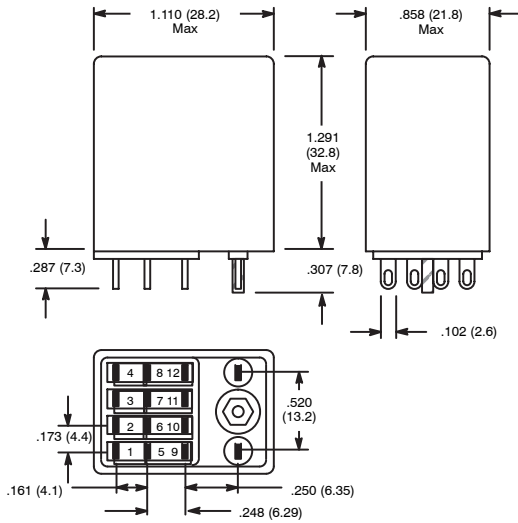

Note: 3-56 Thread Size

D9

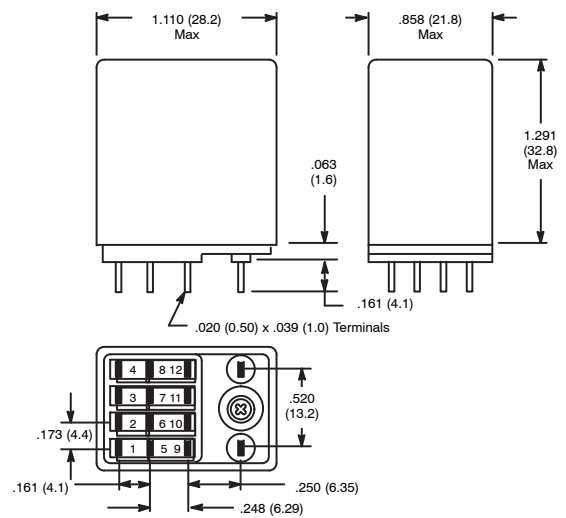

D22

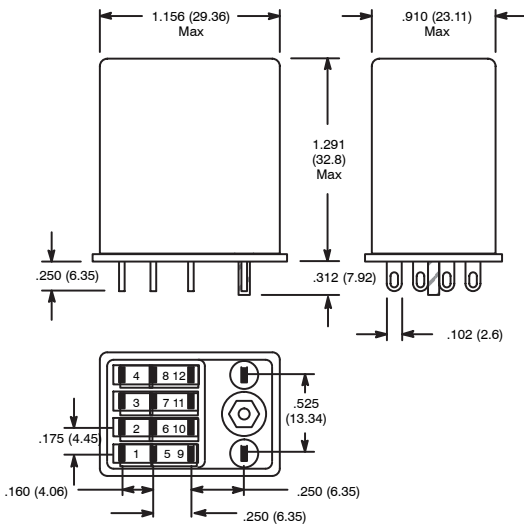

Note: 3-48 Thread Size

D32

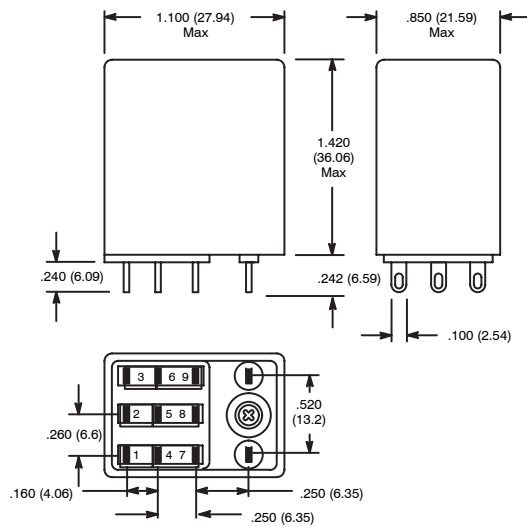

A (DPDT), 2 Form "C"

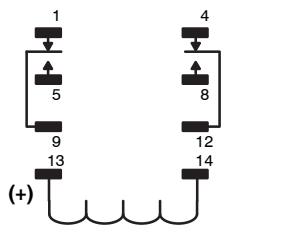

Viewed from Pin end of Plug

B (3PDT), 3 Form "C"

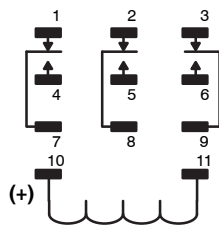

Viewed from Pin end of Plug

C (4PDT), 4 Form "C"

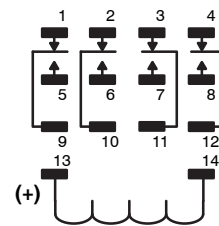

Viewed from Pin end of Plug