

# 158 Series - High Voltage, Open Style Relay

## SPDT - Double Make / Break, 200mA

For HIGH VOLTAGE. Designed with a unique double make / break contact arrangement the 158 series is capable of switching loads up to 1kVA at 5,000 volts. An extra wide contact gap provides excellent arc resistance between contacts. The double break configuration ensures double gaps achieved at higher speeds than single break contacts to extinguish arcs.

### GENERAL SPECIFICATIONS (@ 25° C)

#### Contacts:

Contact Configuration	SPDT-Double Make-Break
Contact Material	Silver Alloy, Gold Flashed
Contact Rating	
Maximum Allowable Contact Load	200mA @ 5,000VDC 1A @ 1,000VDC
Contact Resistance, Initial	100 milliohms max @ 6VDC

#### Coil:

Coils Available	DC
Nominal Coil Power	5W
Input Voltage Tolerance - AC	N/A
Input Voltage Tolerance - DC	80% to 110% of nominal
Drop out voltage	10% of nominal
Duty	Continuous

#### Timing:

Operate Time (max)	45mS
Release Time (max)	20mS

#### Dielectric Strength:

Across Open Contacts	7500 VRMS
Between Mutally Insulated Points	8500 VRMS
Insulation Resistance	1000 megohms @ 500VAC

#### Temperature:

Operating	-40 to 85°C (-40 to 185°F)
Storage	-40 to 105°C (-40 to 221°F)

#### Life Expectancy:

Electrical (full load operations)	100,000
Mechanical (no load operations)	5,000,000

#### Miscellaneous:

Mounting Position	Vertical
Enclosure	Open
Weight	7.5oz (213 grams)



158 Wire Diagram

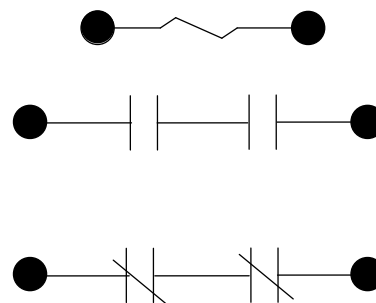

## Outline Dimensions

Dimensions Shown in inches & (millimeters)

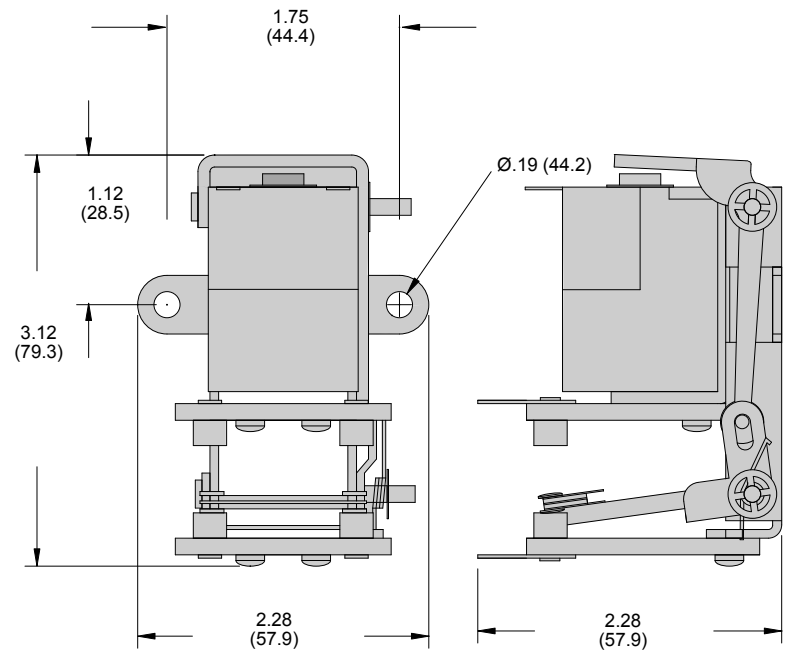

Section 5

## 158 Part Number Chart

Part numbers	Contact configuration	Nominal input voltage	Nominal resistance (ohms)	Nominal power (Watts)
158HVX-1	SPDT-double make/break	24VDC	120	5