



American  
Electronic  
Components, Inc.

*Achieving  
Excellence through  
Commitment to Quality*



# **DURAKOOL**

## Relays & Contactors

*Electrical Controls for over 60 Years*

## Introduction

For more than 60 years, Durakool has specialized in the production of mercury displacement relays and contactors. We helped create mercury switching technology. That experience in developing uses for the inherent qualities of mercury has resulted in components unmatched in quiet and dependable operation.

Durakool products provide silent, reliable switching because of the unique properties of mercury as a contact material. They are virtually immune to breakage, corrosion, or wear. The contacts, enclosed in hermetically sealed steel containers, operate in a wide range of temperatures, under low or high pressures, in dust or vapor filled atmospheres. They produce no external sparks and are unaffected by line noise or voltage spikes.

## Application

Because of their long life, reliability, and unique construction, Durakool relays should be a first choice for applications where continued frequent switching would degrade mechanical devices. They are also the choice if unusual environmental conditions or unpredictable transients are expected, or if replacement would be difficult or costly.

Typical applications include:

- ◆ Resistive heating control
- ◆ Plastic working equipment
- ◆ Industrial processing equipment
- ◆ Oven/furnace controls
- ◆ Food processing equipment
- ◆ Lighting & traffic controls
- ◆ Test/laboratory equipment
- ◆ High-voltage applications
- ◆ Capacitor discharge
- ◆ Motors & pumps

## Construction

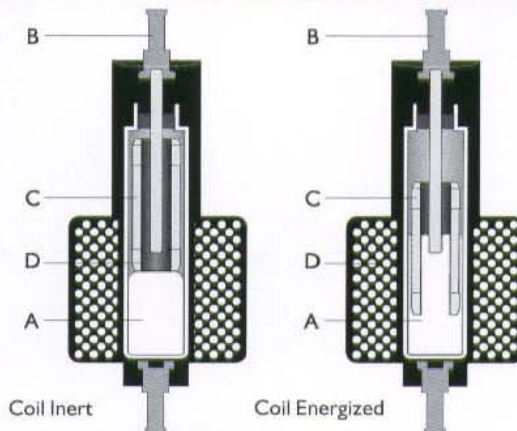

The basic design of a Durakool relay is simplicity itself. A volume of mercury (A) is inside a stainless steel container, the wall of which is one pole of a circuit. An electrode (B), extends into the container through a hermetic seal which also electrically insulates the electrode from the container. A ceramic plunger (C) is attracted by the coil (D), displacing the mercury to close the circuit.

## Selection

Durakool relays and contactors are available with the following options:

- 1) **General Purpose** (UL defined) 10-150 Amps, for inductive, resistive, tungsten, and motor loads.
- 2) **Special Purpose** 30, 35, 50, and 60 Amps, for resistive or motor loads.
- 3) **Time Delay** 6-20 Amps, 0.5-10 second delay.
- 4) **High Voltage** 10 Amps, 2500 to 3500 VAC.

## Relay/Contactor Selection Guide

ELECTRICAL RATINGS	Alternating Current						MOTOR LOAD						Tungsten Lamp	Direct Current			Page #
	Volts						1 Phase			3 Phase				120**	1-48	120	
SERIES	Amps						Hp	Hp	Hp	Hp	Hp	Hp	Amps KW	DC Amps			
<b>GENERAL PURPOSE</b>																	
AFM* 10 (Normally Open)	10	10	10	10	10	10	0.25	0.25	—	—	0.75	—	10 1.2	10	5.0	3.0	6
AFM* 15 (Normally Open)	15	15	15	15	15	15	0.33	0.33	—	—	1.0	—	10 1.2	15	7.5	5.0	6
AFM* 20 (Normally Open)	20	20	20	20	20	20	0.50	0.50	—	—	1.5	—	10 1.2	20	10.0	8.0	6
BF 30 (Normally Open)	30	30	30	30	30	30	2.0	3.0	—	—	5.0	—	30 3.6	30	25	15	8
BB 30 (Normally Closed)	30	22	20	18	10	8	1.5	2.0	—	—	3.0	—	20 2.4	30	20	10	8
BFL 35 (Normally Open)	35	35	35	35	35	15	2.0	3.0	—	—	5.0	—	30 3.6	35	25	15	10
BBL 35 (Normally Closed)	30	22	20	18	10	8	1.5	2.0	—	—	3.0	—	20 2.4	30	20	10	10
BFC 60 (Normally Open)	60	60	60	60	60	60	3.0	5.0	7.5	5.0	10.0	15	60 7.2	60	30	20	12
BBC 60 (Normally Closed)	60	45	45	45	35	25	3.0	5.0	—	5.0	7.5	—	55 6.6	60	30	20	12
CF 80 (Normally Open)	80	80	80	80	80	80	5.0	7.5	—	—	15.0	—	80 9.6	80	35	25	14
CB 80 (Normally Closed)	80	80	80	60	60	40	5.0	7.5	—	—	15.0	—	75 9.0	80	35	25	14
CFC 100 (Normally Open)	100	100	100	100	100	60	7.5	10.0	—	—	20.0	—	100 12.0	100	50	30	16
CBC 100 (Normally Closed)	100	90	90	60	60	70	7.5	10.0	—	—	20.0	—	90 10.8	100	50	30	16
DFC* 150 (Normally Open)	140	140	135	130	120	120	—	—	—	—	—	—	120 14.4	150	70	50	18
<b>RESISTIVE &amp; MOTOR LOADS</b>																	
GL 35A (Normally Open)	35	35	35	35	35	35	—	—	—	—	—	—	35 4.2	35	17	10	20
GLM35A (Normally Open)	35	35	35	35	35	35	2.0	5.0	7.5	3.0	7.5	10.0	35 4.2	35	17	10	20
GL 50A (Normally Open)	50	50	50	50	50	50	—	—	—	—	—	—	50 6.0	50	25	15	20
2030/3030 (Normally Open)	30	30	30	30	30	30	—	—	—	—	—	—	25 —	30	—	—	22
2M30/3M30 (Normally Open)	30	30	30	30	30	30	—	—	—	1.5	3.0	3.0	25 —	30	—	—	23
60APS (Normally Open)	60	60	60	60	60	60	3.0	5.0	7.5	5.0	10.0	15.0	60 —	60	30	—	24
<b>HIGH VOLTAGE CONTACTORS</b>	(2500, 3500 Volts AC) See page 26 for electrical ratings and model numbers.															26	

\* UL Recognized

\*\* Many units have higher ratings.



General Durakool file #'s:

 E35126 & E61703

 LR-22416

**DURAKOOL**  
UL/CSA LISTINGS

The shaded areas in the above selection table indicate relays and contactor applications that are approved for UL or CSA listings. Listings are for all models within a series unless otherwise noted. General Durakool file numbers are listed. Consult your Durakool representative for additional information.

-  Listed with both UL and CSA
-  Listed with UL
-  Listed with CSA

## General Performance Specifications

### TYPICAL CONTACT LIFE AND PERMISSIBLE CYCLE RATES

Resistive loads (Power Factor = 1.0) at 21°C (70°F)

**TABLE 1 Series BB, BBL Mercury/Mercury Contacts**

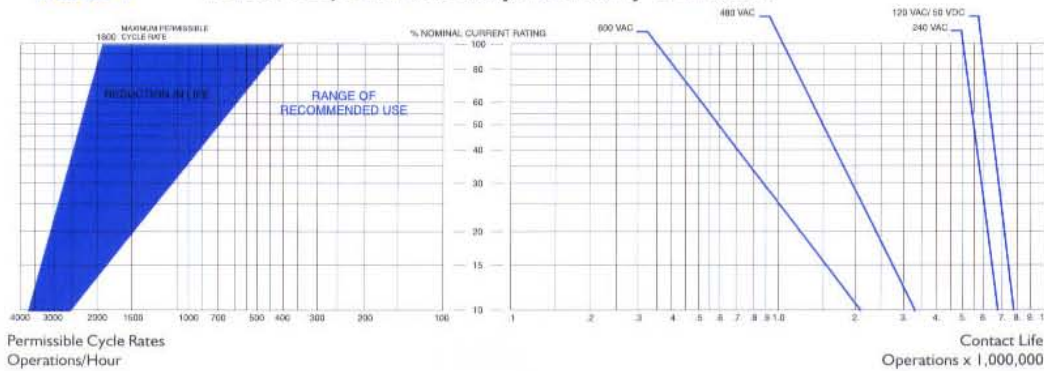

**TABLE 2 Series BFC/BBC, CF/CB, CFC/CBC, DFC, 2030/3030, 2M30/3M30, 60APS Mercury/Metal Contacts**

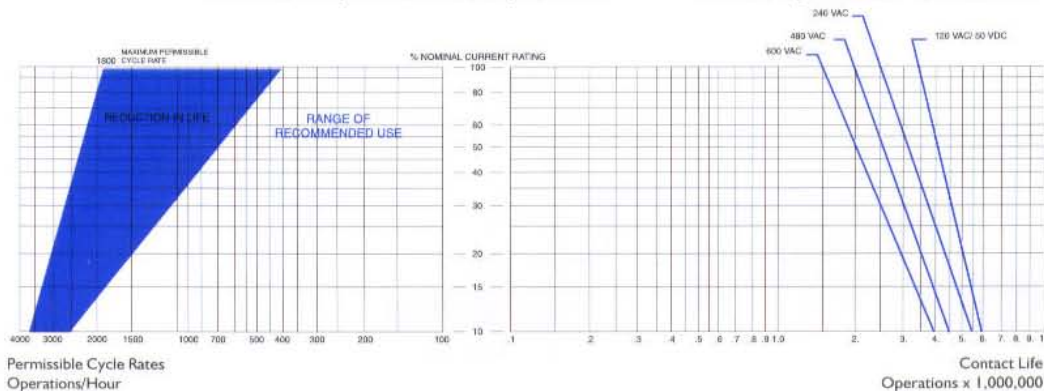

**TABLE 3 Series AFM, Gold Label, BF/BFL**

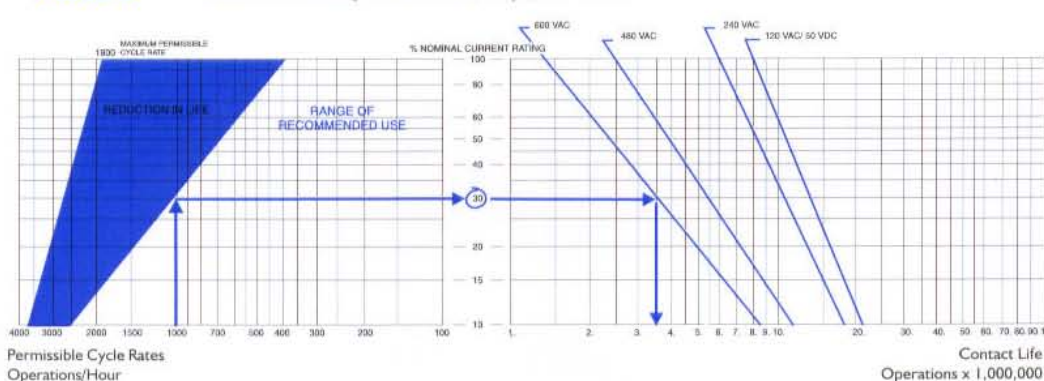

### LIFE CYCLE RATE Example

Refer to Table 3 which shows characteristics for "A" size relays and Gold Label contactors, and follow the blue arrows.

1. For our example load, we have chosen a 12-Amp resistive (600 VAC), with a maximum switching rate of 1000/hour.

2. At this load, the lower left of the table shows us that 1,000 operations per hour allows up to a maximum of 30% of nominal current rating without life reduction.

3. Following 30% across the table to the right, we find that 30% of nominal rating intersects the 600 VAC load line at 3.5 million operations per life.

4. If this contact life is within acceptable parameters, you could calculate that 12 Amps is 30% of a 40-Amp rating (12 divided by 0.30).

5. Applying this information to the table on page 3, we find the 50-Amp Gold Label contactor to be the best selection for our example load.

#### Notes:

##### PERMISSIBLE CYCLE RATES:

For 10-90% duty cycle only. For rates > 1500 cycles/hr., life will be shortened.

##### CONTACT RATES:

Table 2: No-Load Life = 10 megacycles

Table 3: No-Load Life = 25 megacycles

##### AMBIENT TEMPERATURES:

Operating ambient temperature range: -35°C to +55°C.

##### -AFM

GENERAL PURPOSE: If Power Factor = 0.75, then derate life 10%.

INDUCTIVE: If Power Factor = 0.40 and inrush 150% of rated current, derate life 50% (not for jogging loads).

Higher cycle rates approach resistive load values.

FLUORESCENT: 50% of life.

##### -GOLD LABEL

GENERAL PURPOSE: If Power Factor = 0.75, then derate life 10%.

TUNGSTEN: 12,000 cycles life min., 120 VAC (cold lamps only).

Higher cycle rates approach resistive load values.

## General Performance Specifications

**TABLE 4 KW RATINGS**  
For 3-Phase Balanced Heater Loads Based on UL Amps

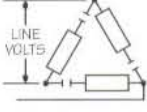
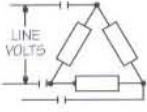
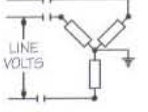
3-Phase Contactor in Circuit		 $KW = 3 I_L V^*$	 $KW = \frac{3 I_L V^*}{\sqrt{3}}$	 $KW = \frac{3 I_L V^*}{\sqrt{3}}$			
Relay Series	Line Volts	Amps Per Pole	Total KW Heater Load	Amps Per Pole	Total KW Heater Load	Amps Per Pole	Total KW Heater Load
BF3	208	30	18.7	30	10.8	30	10.8
	240	30	21.6	30	12.4	30	12.4
	480	30	43.2	30	24.9	30	24.9
BFL3	208	35	21.4	35	12.3	35	12.3
	240	35	25.2	35	14.5	35	14.5
	480	35	50.4	35	29.0	35	29.0
BFC3	208	60	36.7	60	21.5	60	21.5
	240	60	43.2	60	24.9	60	24.9
	480	60	86.4	60	49.8	60	49.8
CFC3	208	100	62.4	100	36.0	100	36.0
	240	100	72.0	100	41.6	100	41.6
	480	100	144.0	100	83.2	100	83.2

\*  $I_L$  = Line Current, V = Voltage

### LEADWIRE PROTECTION

The wire gage must be sufficient to carry the load current. Wire insulation must be rated at a minimum of 60°C above operating ambient temperature required. Other conditions can be accommodated—contact the factory.

### DURAKOOL SPECIFICATIONS

Pull-in Voltage, % of Nominal .....	85
Typical Contact Resistance, Milliohms .....	4
Contact Bounce, Make .....	None
Insulation Material .....	Class B, 130°C
Storage Temperature .....	-40° to +100°C
Breakdown Voltage, VRMS, Min.:	
Contact to Ground .....	5000
Coil to Frame .....	1250
Mounting Vertical .....	± 10°
Operating Ambient Temperature Range .....	-35°C to +55°C

**DURAKOOL Series AFM 10, 15 & 20 Amps**



**1 POLE**  
 Weight .50 lbs.

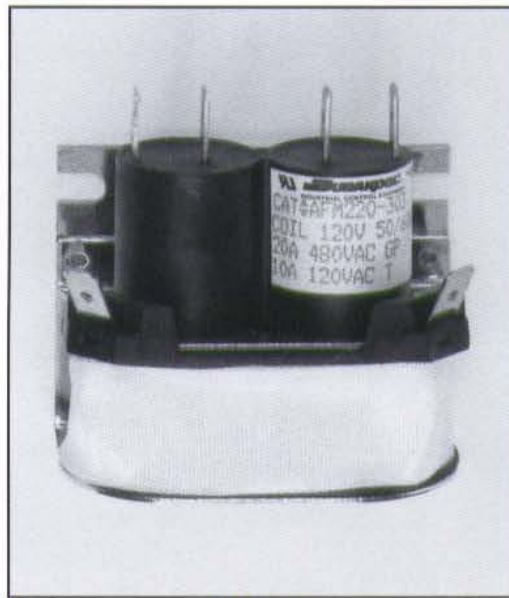

**2 POLE**  
 Weight 1.0 lbs.

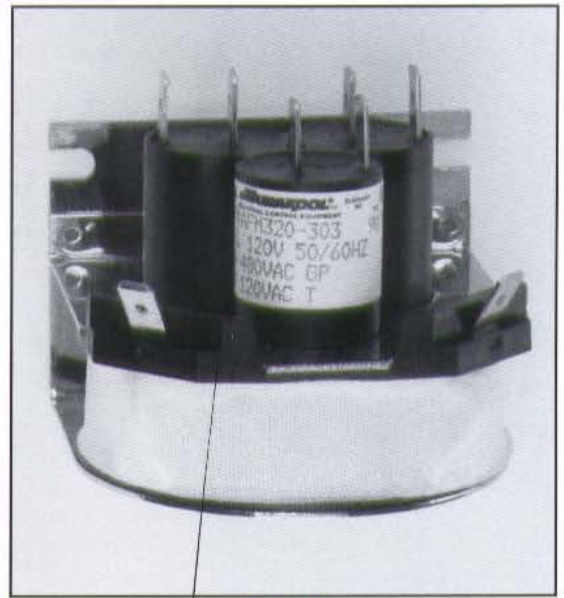

**3 POLE**  
 Weight 1.2 lbs.

**FRONT VIEW**

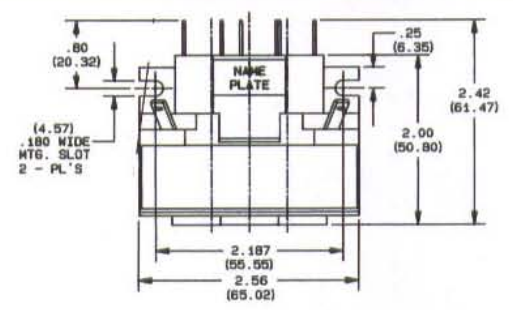
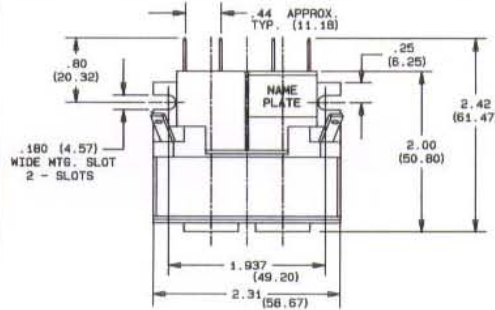
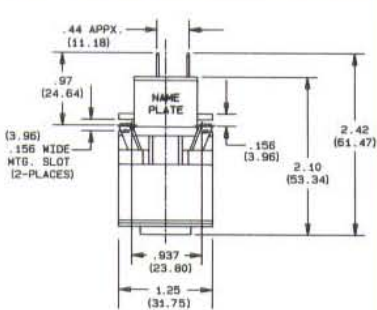

**SIDE VIEW**

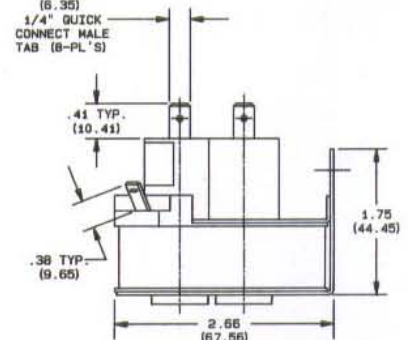
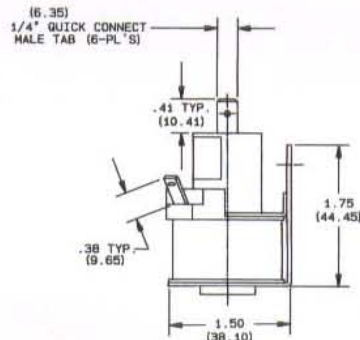
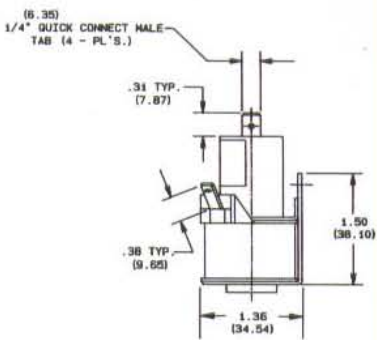

## **DURAKOOL** Series AFM 10, 15 & 20 Amps

AFM "A" size relays offer mercury-contact technology in a cost-effective, compact package in 10, 15, and 20 Amp models. Coil and load connectors are a quick-connect design, mounting brackets simplify installation, and molded construction provides extra durability.

Popular uses of this product include lighting controls, energy management systems, light inductive, and motor loads. The standard part numbers listed below provide a variety of control voltages and load types, and come with normally open contacts.

### SPECIFICATIONS

(see pages 3-5 for other specifications)

Maximum Time: Operate 90 ms Release 150 ms

Contact Bounce, Release: None

Recommended

DC Load Polarity: Center Tube Connector Negative

Load Connectors: 1/4" Male Quick Connect

Coil Terminals: 1/4" Male Quick Connect

Breakdown Voltage: 2000 VRMS/Min. Across Contacts

TYPE/SERIES		AFM 10 10 Amps	AFM 15 15 Amps	AFM 20 20 Amps	Typical Coil Data		
DESCRIPTION	Volts	Part Number	Part Number	Part Number	DC Ohms	Watts	Amps
1 Pole Normally Open	24	AFM10-301-M	AFM15-301-M	AFM20-301-M	126	2.08	0.119
	120	AFM10-303-M	AFM15-303-M	AFM20-303-M	3510	1.70	0.021
	208	AFM10-304-M	AFM15-304-M	AFM20-304-M	10600	1.75	0.021
	240	AFM10-305-M	AFM15-305-M	AFM20-305-M	14040	1.87	0.011
	277	AFM10-306-M	AFM15-306-M	AFM20-306-M	16820	1.90	0.009
	480	AFM10-307-M	AFM15-307-M	AFM20-307-M	56160	2.30	0.006
	12 (DC)	AFM10-309-M	AFM15-309-M	AFM20-309-M	62	2.30	0.192
	24 (DC)	AFM10-310-M	AFM15-310-M	AFM20-310-M	247	2.30	0.097
2 Pole Normally Open	24	AFM210-301	AFM215-301	AFM220-301	52	2.84	0.216
	120	AFM210-303	AFM215-303	AFM220-303	1196	3.60	0.051
	208	AFM210-304	AFM215-304	AFM220-304	3400	3.20	0.027
	240	AFM210-305	AFM215-305	AFM220-305	5385	2.90	0.020
	277	AFM210-306	AFM215-306	AFM220-306	7520	3.10	0.018
	480	AFM210-307	AFM215-307	AFM220-307	21100	2.90	0.011
	12 (DC)	AFM210-309	AFM215-309	AFM220-309	33.2	4.32	0.360
	24 (DC)	AFM210-310	AFM215-310	AFM220-310	144	3.84	0.160
3 Pole Normally Open	24	AFM310-301	AFM315-301	AFM320-301	17	6.70	0.554
	120	AFM310-303	AFM315-303	AFM320-303	470	7.26	0.112
	208	AFM310-304	AFM315-304	AFM320-304	1690	6.47	0.055
	240	AFM310-305	AFM315-305	AFM320-305	1950	5.60	0.046
	277	AFM310-306	AFM315-306	AFM320-306	2130	5.90	0.043
	480	AFM310-307	AFM315-307	AFM320-307	7800	6.47	0.024
	12 (DC)	AFM310-309	AFM315-309	AFM320-309	20	7.20	0.600
	24 (DC)	AFM310-310	AFM315-310	AFM320-310	118	4.80	0.200

ELECTRICAL RATINGS	GENERAL PURPOSE 0.7/0.8 UL Power Factor						DC			Tungsten Lamp/60 Hz		AC MOTOR LOAD		
	Volts						1-48 120 240			120	120 240		240	
SERIES	60 Hz Amps						DC Amps			Amps	KW	Hp	Hp	Hp
AFM 10 (Normally Open)	10	10	10	10	10	10	10	5.0	3.0	10	1.2	0.25	0.25	0.75
AFM 15 (Normally Open)	15	15	15	15	15	15	15	7.5	5.0	10	1.2	0.33	0.33	1.00
AFM 20 (Normally Open)	20	20	20	20	20	20	20	10.0	8.0	10	1.2	0.50	0.50	1.50

UL E35126 & E61703

SF LR-22416

**DURAKOOL Series BF (Open) & BB (Closed) 30 Amps**



**1 POLE**  
Weight 1.0 lbs.

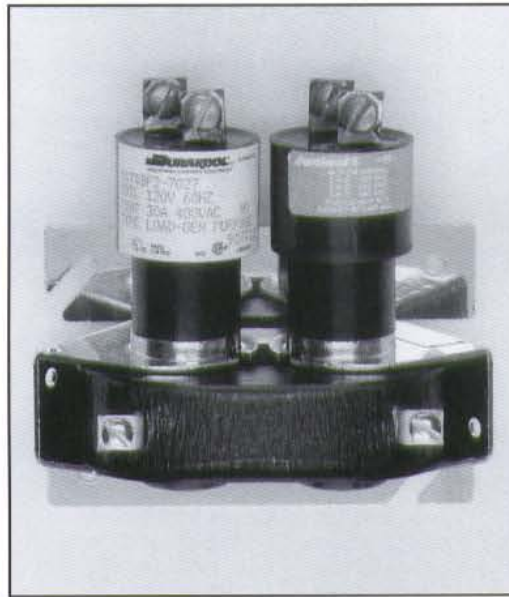

**2 POLE**  
Weight 1.5 lbs.

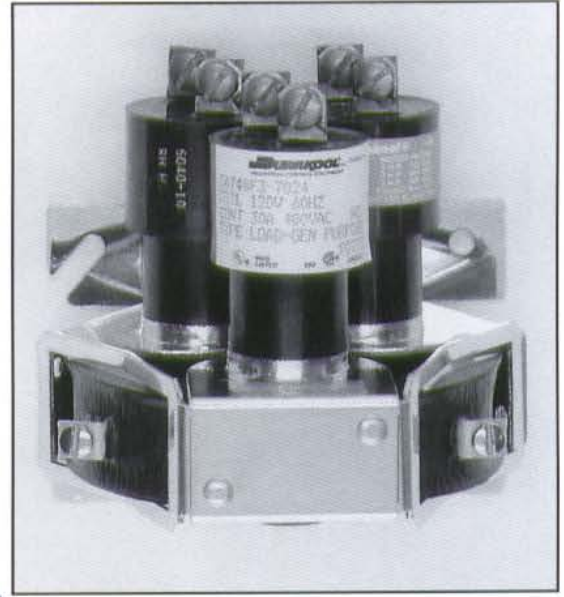

**3 POLE**  
Weight 2.5 lbs.

**FRONT VIEW**

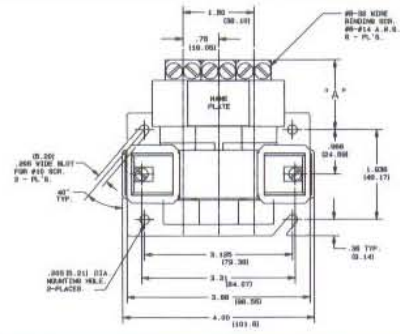
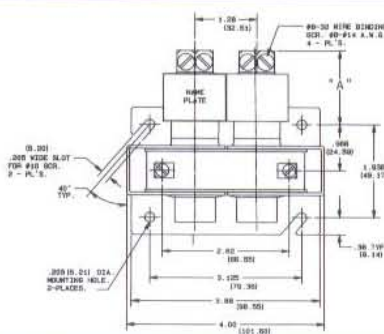
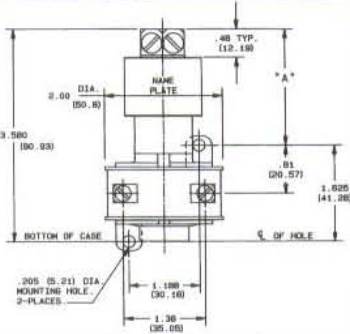

**SIDE VIEW**

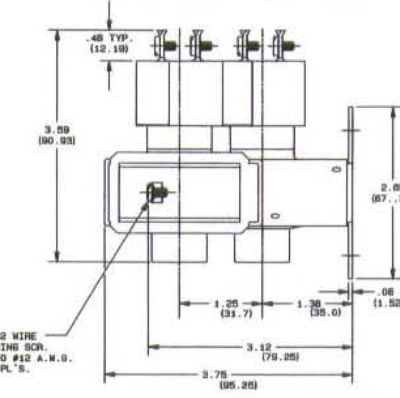
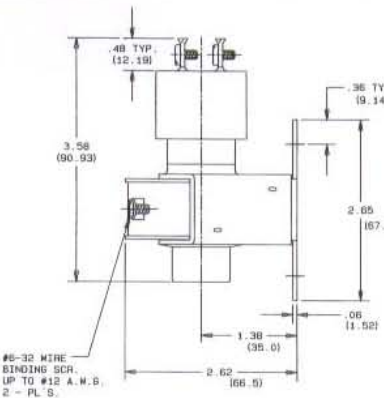
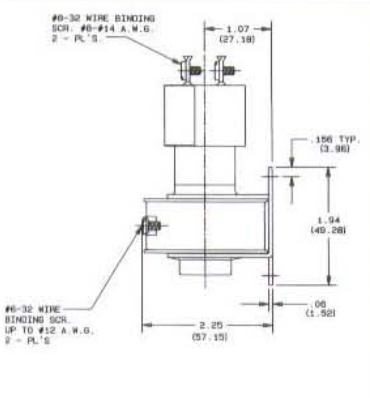

**DIMENSION "A"**

Hz	BF		BB		BF2		BB2		BF3		BB3	
	in.	mm	in.	mm	in.	mm	in.	mm	in.	mm	in.	mm
DC	1.69	42.9	1.59	40.4	1.57	39.9	1.44	36.6	1.57	39.9	1.44	36.6
50	1.86	47.2	1.54	39.1	1.57	39.9	1.39	35.3	1.57	39.9	1.39	35.3
50/60	1.86	47.2	1.54	39.1	1.57	39.9	1.39	35.3	1.57	39.9	1.39	35.3
60	1.86	47.2	1.54	39.1	1.57	39.9	1.39	35.3	1.57	39.9	1.39	35.3



## DURAKOOL Series BF (Open) & BB (Closed) 30 Amps

Durakool 30 Amp general purpose contactors are available in 1, 2, and 3 pole configurations to suit a variety of design needs.

The BF (normally open) and BB (normally closed) both feature long-life contacts which provide low, stable contact resistance. Screw terminals are included for both load and control connections. The top wiring style of the load terminals allows efficient use of available panel space.

### SPECIFICATIONS

(see pages 3-5 for other specifications)

Maximum Time:	Operate	Release
Normally Open:	70 ms	90 ms
Normally Closed:	150 ms	200 ms
Contact Bounce, Release:	None	
Recommended		
DC Load Polarity:	Center Tube Connector Negative	
Load Connectors:	*8-32 Wire Binding Screw, Max. #8 AWG Cu.	
Coil Terminals:	*6-32 Wire Binding Screw, Max. #12 AWG Cu.	
Breakdown Voltage:	5000 VRMS/Min. Across Contacts	

TYPE/SERIES		BF (Normally Open)				BB (Normally Closed)			
DESCRIPTION	Volts	Part Number	Typical Coil Data			Part Number	Typical Coil Data		
			DC Ohms	Watts	Amps		DC Ohms	Watts	Amps
1 Pole	24	BF-7031	40	2.80	0.233	BB-7001	40	2.00	0.189
	120	BF-7032	902	3.69	0.057	BB-7002	902	2.50	0.046
	208	BF-7033	3100	3.46	0.030	BB-7003	3100	2.50	0.026
	240	BF-7034	3700	3.14	0.025	BB-7004	3700	2.10	0.021
	277	BF-7035	5410	3.42	0.022	BB-7005	5410	2.50	0.017
	480	BF-7036	15000	3.49	0.013	BB-7006	15000	2.70	0.010
	12 <sub>(DC)</sub>	BF-7058	57	2.50	0.210	BB-7027	57	2.50	0.209
	24 <sub>(DC)</sub>	BF-7046	230	2.50	0.104	BB-7007	230	2.35	0.098
2 Pole	24	BF2-7026	15	5.10	0.529	BB2-2001	15	4.00	0.431
	120	BF2-7027	350	7.10	0.130	BB2-2020	350	5.60	0.108
	208	BF2-7028	960	7.00	0.075	BB2-2002	960	5.50	0.062
	240	BF2-7029	1520	5.70	0.055	BB2-2032	1520	4.30	0.046
	277	BF2-7030	2300	5.70	0.045	BB2-2024	2300	4.50	0.037
	480	BF2-7031	5600	5.80	0.029	BB2-2003	5600	4.60	0.023
	12 <sub>(DC)</sub>	BF2-7041	24	6.00	0.500	BB2-2018	24	6.20	0.513
	24 <sub>(DC)</sub>	BF2-7032	90	6.40	0.266	BB2-2004	90	6.00	0.250
3 Pole	24	BF3-7023	5	11.10	1.270	BB3-2008	5	9.20	1.070
	120	BF3-7024	135	9.20	0.220	BB3-2002	135	7.70	0.184
	208	BF3-7025	480	8.70	0.111	BB3-2009	480	7.20	0.094
	240	BF3-7026	520	9.20	0.109	BB3-2010	520	7.60	0.093
	277	BF3-7027	830	8.10	0.081	BB3-2011	830	6.70	0.067
	480	BF3-7028	2100	9.40	0.055	BB3-2012	2100	8.20	0.044
	12 <sub>(DC)</sub>	BF3-7037	12.8	11.20	0.938	BB3-2013	12.8	10.60	0.883
	24 <sub>(DC)</sub>	BF3-7038	51	11.30	0.470	BB3-2014	51	11.10	0.460

ELECTRICAL RATINGS	GENERAL PURPOSE 0.7/0.8 UL Power Factor						DC			Tungsten Lamp/60 Hz	AC MOTOR LOAD			
	120	208	240	277	480	600	1-48	120	240	120	1 Phase		3 Phase	
Volts											120	240	240	
SERIES	60 Hz Amps						DC Amps			Amps	KW	Hp	Hp	Hp
BF 30 (Normally Open)	30	30	30	30	30	30	30	25	15	30	3.6	2.0	3.0	5.0
BB 30 (Normally Closed)	30	22	20	18	10	8	30	20	10	20	2.4	1.5	2.0	3.0

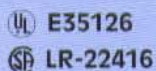

## DURAKOOL Series BFL (Open) & BBL (Closed) 35 Amps



**1 POLE**  
Weight 1.0 lbs.

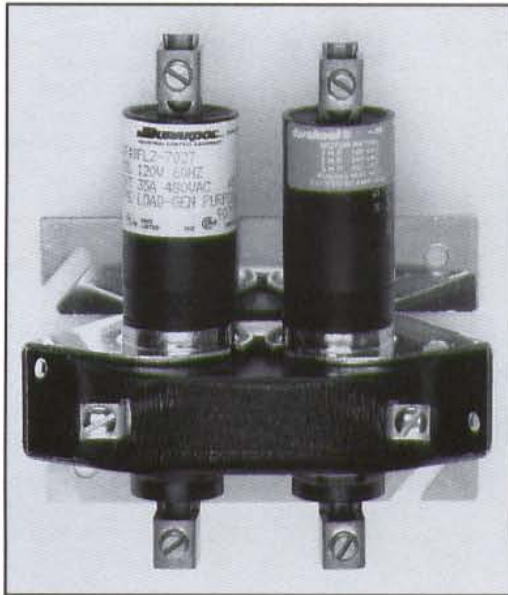

**2 POLE**  
Weight 2.0 lbs.

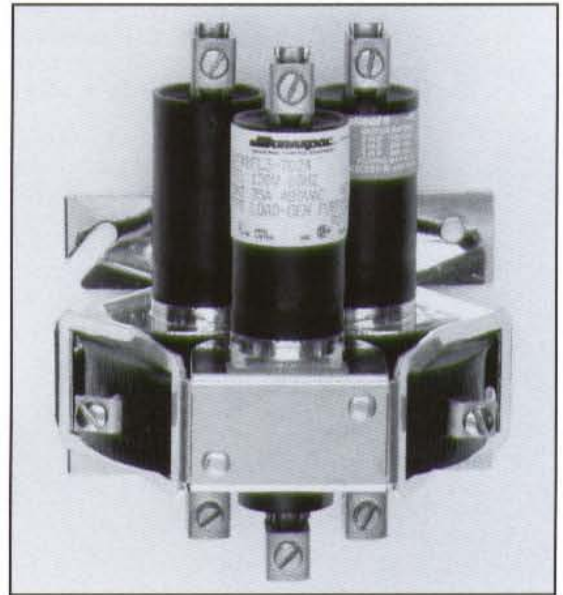

**3 POLE**  
Weight 3.0 lbs.

**FRONT VIEW**

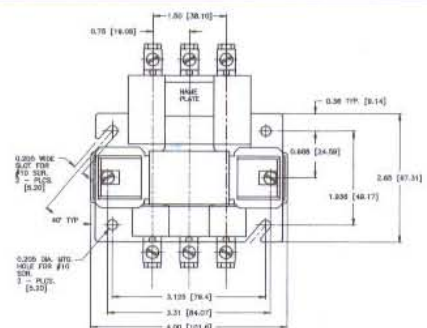
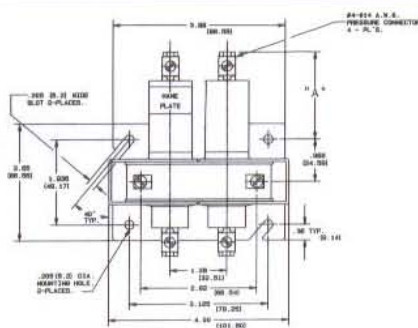
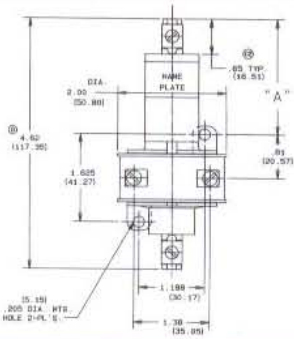

**SIDE VIEW**

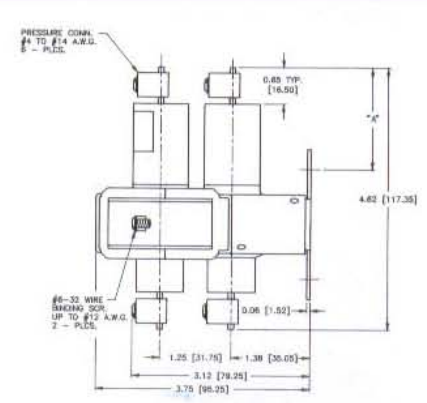
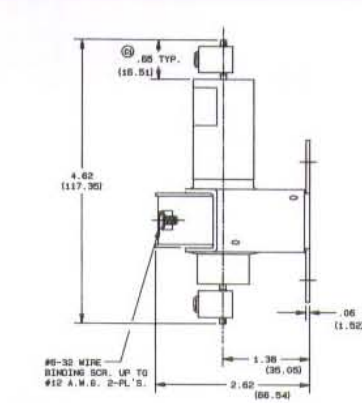
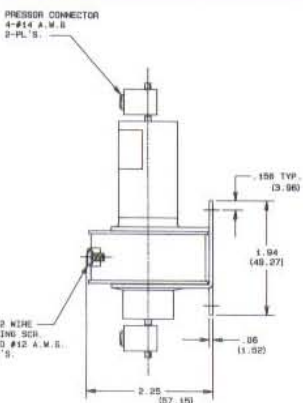

**DIMENSION "A"**

Hz	BFL		BBL		BFL2		BBL2		BFL3		BBL3	
	in.	mm	in.	mm	in.	mm	in.	mm	in.	mm	in.	mm
DC	2.00	50.8	2.08	52.8	1.84	46.7	1.92	48.8	1.84	46.7	1.92	48.8
50	2.00	50.8	2.03	51.6	1.84	46.7	1.87	47.5	1.84	46.7	1.87	47.5
50/60	2.00	50.8	2.03	51.6	1.84	46.7	1.87	47.5	1.84	46.7	1.87	47.5
60	2.00	50.8	2.03	51.6	1.84	46.7	1.87	47.5	1.84	46.7	1.87	47.5

## **DURAKOOL** Series BFL (Open) & BBL (Closed) 35 Amps

These 35 Amp general purpose contactors offer additional load capacity as well as long contact-life performance. Top/bottom compression lug termination style allows easy connection to heavier leadwire (up to #4 AWG Copper).

Both BFL (normally open) and BBL (normally closed) are available in 1, 2, or 3 pole configurations, and feature low, stable contact resistance.

### SPECIFICATIONS



(see pages 3-5 for other specifications)

Maximum Time:	Operate	Release
Normally Open:	70 ms	90 ms
Normally Closed:	150 ms	200 ms
Contact Bounce, Release:	None	
Recommended		
DC Load Polarity:	Top Connector Negative	
Load Connectors:	Pressure Connector #4-14 AWG Cu.	
Coil Terminals:	#6-32 Wire Binding Screw, Max. #12 AWG Cu.	
Breakdown Voltage:	5000 VRMS/Min. Across Contacts	

TYPE/SERIES		BFL (Normally Open)				BBL (Normally Closed)			
DESCRIPTION	Volts	Part Number	Typical Coil Data			Part Number	Typical Coil Data		
			DC Ohms	Watts	Amps		DC Ohms	Watts	Amps
1 Pole	24	BFL-7031	40	2.80	0.233	BBL-1002	40	2.00	0.189
	120	BFL-7032	902	3.69	0.057	BBL-1011	902	2.50	0.046
	208	BFL-7033	3100	3.46	0.030	BBL-1003	3100	2.50	0.026
	240	BFL-7034	3700	3.14	0.025	BBL-1004	3700	2.10	0.021
	277	BFL-7035	5410	3.42	0.022	BBL-1005	5410	2.50	0.017
	480	BFL-7036	15000	3.49	0.013	BBL-1006	15000	2.70	0.010
	12(DC)	BFL-7058	57	2.50	0.210	BBL-1007	57	2.50	0.209
	24(DC)	BFL-7048	230	2.50	0.104	BBL-1008	230	2.35	0.098
	2 Pole	24	BFL2-7026	15	5.10	0.529	BBL2-1001	15	4.00
120		BFL2-7027	350	7.10	0.130	BBL2-1002	350	5.60	0.108
208		BFL2-7028	960	7.00	0.075	BBL2-1003	960	5.50	0.062
240		BFL2-7029	1520	5.70	0.055	BBL2-1004	1520	4.30	0.046
277		BFL2-7030	2300	5.70	0.045	BBL2-1005	2300	4.50	0.037
480		BFL2-7031	5600	5.80	0.029	BBL2-1006	5600	4.60	0.023
12(DC)		BFL2-7041	24	6.00	0.500	BBL2-1007	24	6.00	0.500
24(DC)		BFL2-7032	90	6.40	0.266	BBL2-1008	90	6.40	0.266
3 Pole		24	BFL3-7023	5	11.10	1.270	BBL3-1001	5	11.10
	120	BFL3-7024	135	9.20	0.220	BBL3-1002	135	9.20	0.220
	208	BFL3-7025	480	8.70	0.111	BBL3-1003	480	7.20	0.094
	240	BFL3-7026	520	9.20	0.109	BBL3-1004	520	7.60	0.093
	277	BFL3-7027	830	8.10	0.081	BBL3-1005	830	6.70	0.067
	480	BFL3-7028	2100	9.40	0.055	BBL3-1006	2100	8.20	0.044
	12(DC)	BFL3-7037	12.8	11.20	0.938	BBL3-1007	12.8	10.60	0.883
	24(DC)	BFL3-7038	51	11.30	0.470	BBL3-1008	51	11.10	0.460

50 Hz models also available.

ELECTRICAL RATINGS	GENERAL PURPOSE 0.7/0.8 UL Power Factor						DC			Tungsten Lamp/60 Hz	AC MOTOR LOAD			
	120	208	240	277	480	600	1-48	120	240	120	1 Phase		3 Phase	
Volts											120	240	240	
SERIES	60 Hz Amps						DC Amps			Amps	KW	Hp		Hp
BFL 35 (Normally Open)	35	35	35	35	35	15	35	25	15	30	3.6	2.0	3.0	5.0
BBL 35 (Normally Closed)	30	22	20	18	10	8	30	20	10	20	2.4	1.5	2.0	3.0

 **E35126**  
 **LR-22416**

# DURAKOOL Series BFC (Open) & BBC (Closed) 60 Amps



**1 POLE**  
Weight 1.0 lbs.

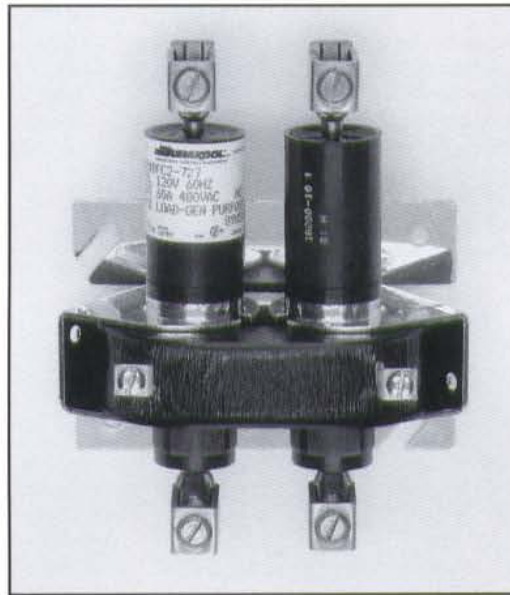

**2 POLE**  
Weight 2.0 lbs.

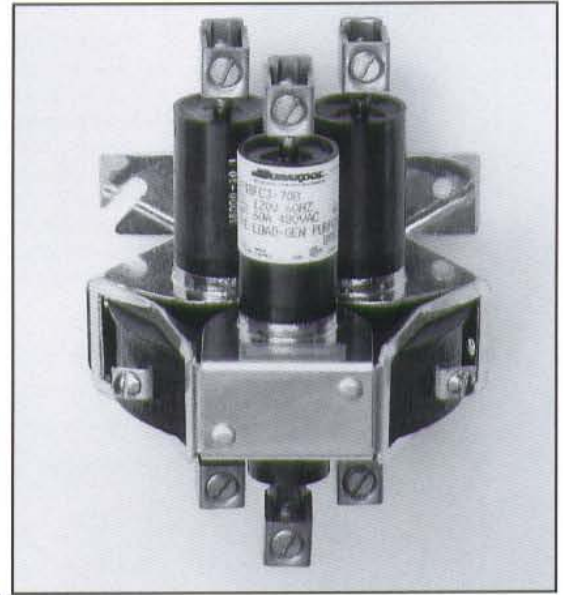

**3 POLE**  
Weight 3.0 lbs.

**FRONT VIEW**

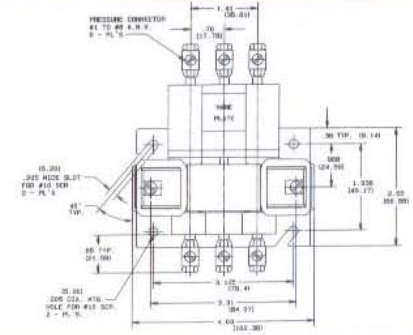
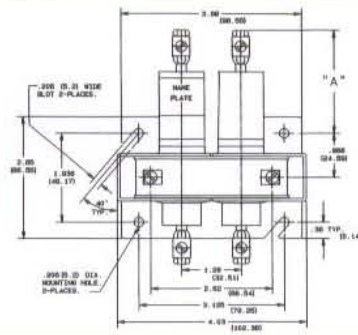
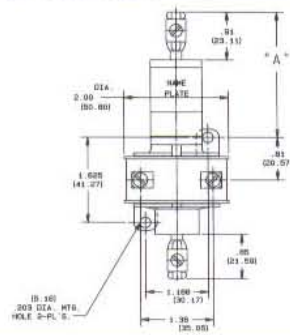

**SIDE VIEW**

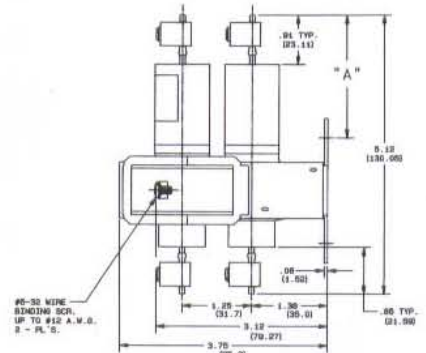
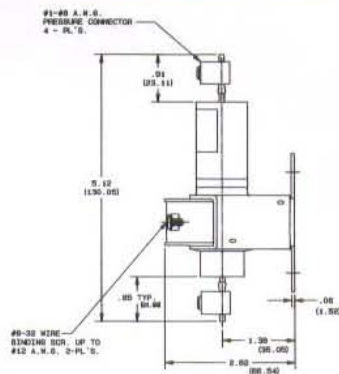
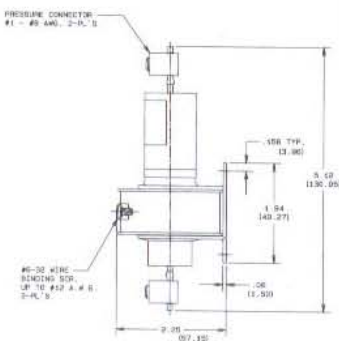

**DIMENSION "A"**

Hz	BFC		BBC		BFC2		BBC2		BFC3		BBC3	
	in.	mm	in.	mm	in.	mm	in.	mm	in.	mm	in.	mm
DC	2.32	58.9	2.15	54.6	2.17	55.1	2.00	50.8	2.17	55.1	2.00	50.8
50	2.41	61.2	2.10	53.3	2.26	57.4	1.95	49.5	2.26	57.4	1.95	49.5
50/60	2.41	61.2	2.10	53.3	2.26	57.4	1.95	49.5	2.26	57.4	1.95	49.5
60	2.41	61.2	2.10	53.3	2.26	57.4	1.95	49.5	2.26	57.4	1.95	49.5

## DURAKOOL Series BFC (Open) & BBC (Closed) 60 Amps

The unusually long life of Durakool "B" size contactors in proportional temperature control systems has made them the most popular choice of designers of process heating controls.

BFC (normally open) and BBC (normally closed) contactors are general purpose, 60 Amp rated, featuring mercury-to-tungsten contacts. Tungsten's ability to resist arcing erosion greatly prolongs the life of the contactor. These relays can be used in plastic extrusion equipment to cycle heaters for precise temperature control.

### SPECIFICATIONS

(see pages 3-5 for other specifications)

Maximum Time:	Operate	Release
Normally Open:	70 ms	90 ms
Normally Closed:	120 ms	90 ms
Contact Bounce, Release:	None	
Recommended		
DC Load Polarity:	Top Connector Negative	
Load Connectors:	Pressure Connector #1-8 AWG Cu.	
Coil Terminals:	#6-32 Wire Binding Screw, Max. #12 AWG Cu.	
Breakdown Voltage:	5000 VRMS/Min. Across Contacts	

TYPE/SERIES	BFC (Normally Open)					BBC (Normally Closed)				
	DESCRIPTION	Volts	Typical Coil Data			Part Number	Typical Coil Data			
Part Number			DC Ohms	Watts	Amps		DC Ohms	Watts	Amps	
1 Pole	24	BFC-716	40	2.60	0.235	BBC-701	40	2.80	0.229	
	120	BFC-717	902	3.47	0.055	BBC-702	902	3.50	0.055	
	208	BFC-718	3100	3.50	0.029	BBC-703	3100	3.40	0.029	
	240	BFC-719	3700	3.40	0.026	BBC-704	3700	2.90	0.024	
	277	BFC-720	5410	3.46	0.022	BBC-705	5410	3.40	0.020	
	480	BFC-721	15000	3.54	0.012	BBC-706	15000	3.60	0.010	
	12 <sub>(DC)</sub>	BFC-730	57	3.64	0.293	BBC-719	57	2.50	0.214	
	24 <sub>(DC)</sub>	BFC-722	230	3.48	0.146	BBC-707	230	2.40	0.099	
	2 Pole	24	BFC2-726	15	5.20	0.515	BBC2-309	15	5.00	0.510
		120	BFC2-727	350	7.46	0.133	BBC2-305	350	6.60	0.123
208		BFC2-728	960	7.39	0.076	BBC2-310	960	6.30	0.070	
240		BFC2-729	1520	6.18	0.056	BBC2-306	1520	5.40	0.054	
277		BFC2-730	2300	6.14	0.045	BBC2-311	2300	5.50	0.044	
480		BFC2-731	5600	6.47	0.027	BBC2-312	5600	5.60	0.027	
12 <sub>(DC)</sub>		BFC2-741	24	6.10	0.506	BBC2-313	24	6.00	0.500	
24 <sub>(DC)</sub>		BFC2-733	90	6.00	0.253	BBC2-308	90	6.00	0.250	
3 Pole		24	BFC3-707	4.5	3.65	2.492	BBC3-308	5	10.20	1.170
		120	BFC3-708	122	9.54	0.224	BBC3-303	135	8.80	0.208
	208	BFC3-709	430	8.66	0.112	BBC3-309	480	8.60	0.108	
	240	BFC3-710	470	9.47	0.110	BBC3-306	520	8.60	0.104	
	277	BFC3-711	747	8.22	0.081	BBC3-310	830	7.80	0.077	
	480	BFC3-712	1900	10.12	0.055	BBC3-311	2100	9.40	0.050	
	12 <sub>(DC)</sub>	BFC3-720	11.5	10.10	0.866	BBC3-312	12.8	10.70	0.890	
	24 <sub>(DC)</sub>	BFC3-721	46	11.10	0.461	BBC3-313	51	11.30	0.470	

50 Hz models also available.

ELECTRICAL RATINGS	GENERAL PURPOSE 0.7/0.8 UL Power Factor						DC			Tungsten Lamp/60 Hz	AC MOTOR LOAD						
	60 Hz Amps						DC Amps			Amps KW	1 Phase			3 Phase			
Volts	120	208	240	277	480	600	1-48	120	240	120		120	240	480	120	240	480
SERIES										Amps KW	Hp	Hp	Hp	Hp	Hp	Hp	Hp
BFC 60 (Normally Open)	60	60	60	60	60	60	60	30	20	60	7.2	3.0	5.0	7.5	5.0	10.0	15.0
BBC 60 (Normally Closed)	60	45	45	45	35	25	60	30	20	55	6.6	3.0	5.0	—	5.0	7.5	—

UL E35126 & E61703 SF LR-22416	DEFINITE PURPOSE MOTOR RATING, SERIES BFC				
	VAC	Breaking All Lines FLA LRA		1 Phase FLA	1 Pole LRA
	240	26	156	—	—
480	14	80	14	80	

# DURAKOOL Series CF (Open) & CB (Closed) 80 Amps



**1 POLE**  
Weight 2.0 lbs.

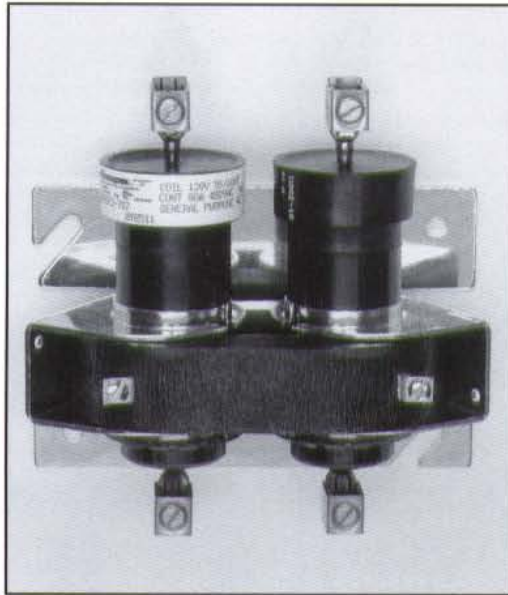

**2 POLE**  
Weight 3.5 lbs.

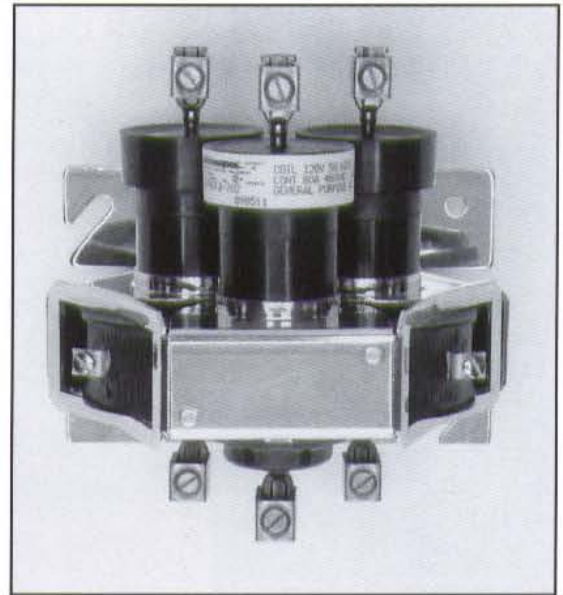

**3 POLE**  
Weight 4.5 lbs.

**FRONT VIEW**

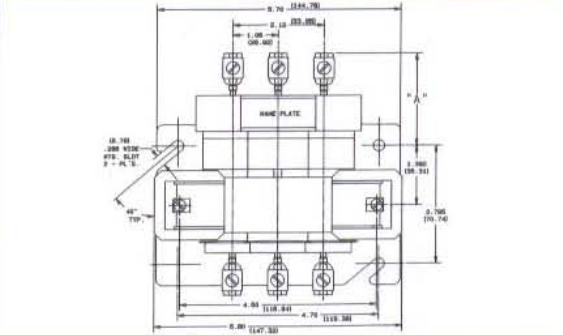
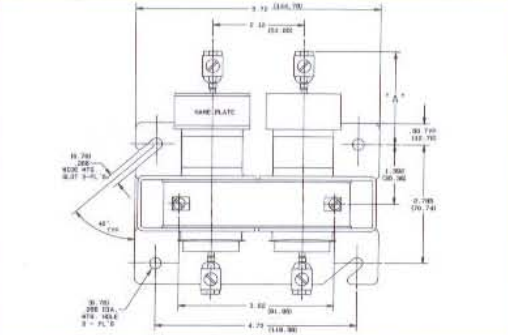
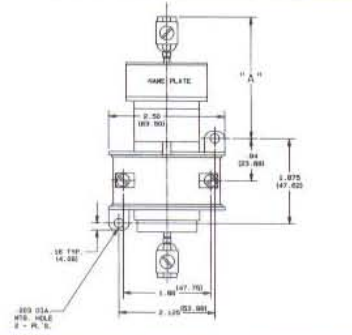

**SIDE VIEW**

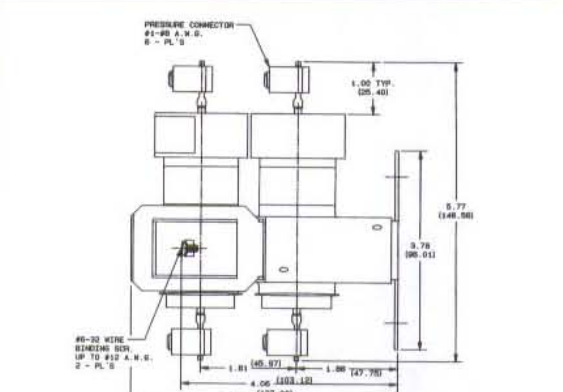
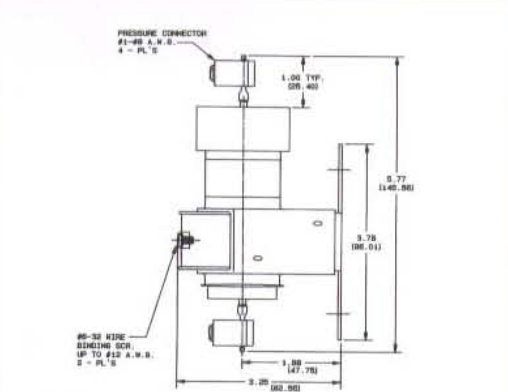
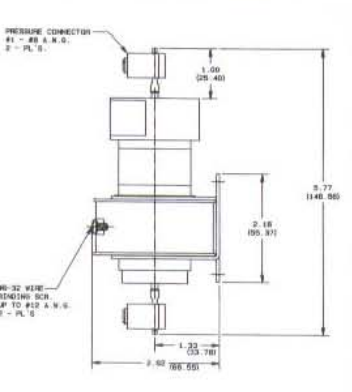

**DIMENSION "A"**

Hz	CF		CB		CF2		CB2		CF3		CB3	
	in.	mm	in.	mm	in.	mm	in.	mm	in.	mm	in.	mm
DC	2.39	60.7	2.04	51.8	1.93	49.0	1.58	40.1	1.93	49.0	1.58	40.1
50	2.62	66.5	2.02	51.3	2.16	54.9	1.56	39.6	2.16	54.9	1.56	39.6
50/60	2.66	67.6	2.02	51.3	2.21	56.1	1.56	39.6	2.21	56.1	1.56	39.6
60	2.66	67.6	1.92	48.8	2.21	56.1	1.46	37.1	2.21	56.1	1.46	37.1

## DURAKOOL Series CF (Open) & CB (Closed) 80 Amps

These Durakool CF (normally open) and CB (normally closed) contactors are general-purpose rated at 80 Amps. Compression-lug connectors, top and bottom, provide easy installation.

"C" size Durakool contactors have mercury-to-tungsten contacts which can handle inductive, tungsten, motor and resistive loads. Tungsten's ability to resist arcing erosion greatly prolongs the life of the contactor.

### SPECIFICATIONS

(see pages 3-5 for other specifications)

Maximum Time:	Operate	Release
Normally Open:	90 ms	140 ms
Normally Closed:	200 ms	100 ms
Contact Bounce, Release:	Allowed on normally open models	
Recommended		
DC Load Polarity:	Top Connector Negative	
Load Connectors:	Pressure Connector #1-8 AWG Cu.	
Coil Terminals:	#6-32 Wire Binding Screw, Max. #12 AWG Cu.	
Breakdown Voltage:	5000 VRMS/Min. Across Contacts	

TYPE/SERIES	DESCRIPTION	CF (Normally Open)				CB (Normally Closed)				
		Part Number	Typical Coil Data			Part Number	Typical Coil Data			
	Volts		DC Ohms	Watts	Amps		DC Ohms	Watts	Amps	
1 Pole	24	CF-701	7.1	9.6	0.930	CB-306	7.1	7.7	0.837	
	120	CF-702	180	10.2	0.195	CB-301	180	8.5	0.179	
	208	CF-703	600	9.5	0.097	CB-307	600	7.6	0.087	
	240	CF-704	680	10.8	0.103	CB-304	680	9.3	0.093	
	277	CF-705	1000	9.8	0.079	CB-308	1000	8.0	0.070	
	480	CF-706	2700	11.8	0.052	CB-309	2700	9.4	0.046	
	12 (DC)	CF-730	27	5.2	0.436	CB-310	27	5.3	0.441	
	24 (DC)	CF-707	111	5.2	0.217	CB-311	111	5.2	0.217	
	2 Pole	24	CF2-701	2.8	22.2	2.310	CB2-301	2.8	17.0	2.120
		120	CF2-702	66	21.6	0.448	CB2-302	66	17.8	0.408
208		CF2-703	165	23.9	0.280	CB2-303	165	20.2	0.265	
240		CF2-704	260	18.9	0.202	CB2-304	260	15.4	0.182	
277		CF2-705	430	18.4	0.164	CB2-305	430	14.5	0.145	
480		CF2-706	1100	21.0	0.104	CB2-306	1100	16.6	0.094	
12 (DC)		CF2-707	10	13.8	1.153	CB2-308	10	14.3	1.194	
24 (DC)		CF2-708	40	13.6	0.570	CB2-307	40	13.6	0.570	
3 Pole	24	CF3-701	1.4	47.0	5.060	CB3-301	1.4	40.0	4.720	
	120	CF3-702	23	39.0	0.924	CB3-302	23	33.3	0.850	
	208	CF3-703	100	26.6	0.388	CB3-303	100	23.0	0.345	
	240	CF3-704	110	27.7	0.361	CB3-304	110	24.0	0.321	
	277	CF3-705	150	31.5	0.327	CB3-305	150	26.9	0.294	
	480	CF3-706	440	28.8	0.185	CB3-306	440	24.2	0.162	
	12 (DC)	CF3-707	10	13.5	1.127	CB3-308	10	13.4	1.120	
	24 (DC)	CF3-708	40	13.3	0.555	CB3-307	40	13.4	0.558	

50 Hz models also available.

ELECTRICAL RATINGS	GENERAL PURPOSE 0.7/0.8 UL Power Factor							DC			Tungsten Lamp/60 Hz	AC MOTOR LOAD			
	Volts							1-48	120	240	120	1 Phase		3 Phase	
SERIES	60 Hz Amps							DC Amps			Amps	KW	Hp	Hp	Hp
	CF 80 (Normally Open)	80	80	80	80	80	80	80	35	25	80	9.6	5.0	7.5	15.0
CB 80 (Normally Closed)	80	80	80	60	60	40	80	35	25	75	9.0	5.0	7.5	15.0	

UL E35126  
SF LR-22416





## DURAKOOL Series CFC (Open) & CBC (Closed) 100 Amps

Durakool mercury contactors are a favorite choice for high reliability lighting and heating control. Their low maintenance and excellent tungsten in-rush handling characteristics provide dependable long-term operation. CFC (normally open) and CBC (normally closed) contactors are general purpose rated at 100 Amps. Top and bottom compression-lug connectors provide secure connection.

"C" size Durakool contactors have mercury-to-tungsten contacts for easy handling of inductive, tungsten, motor and resistive loads. Tungsten's resistance to arcing erosion prolongs the life of the contactor.

### SPECIFICATIONS

(see pages 3-5 for other specifications)

<b>Maximum Time:</b>	<b>Operate</b>	<b>Release</b>
<b>Normally Open:</b>	90 ms	140 ms
<b>Normally Closed:</b>	200 ms	100 ms
<b>Contact Bounce, Release:</b>	Allowed on normally open models	
<b>Recommended DC Load Polarity:</b>	Top Connector Negative	
<b>Load Connectors:</b>	Pressure Connector #1-8 AWG Cu.	
<b>Coil Terminals:</b>	#6-32 Wire Binding Screw, Max. #12 AWG Cu.	
<b>Breakdown Voltage:</b>	5000 VRMS/Min. Across Contacts	

TYPE/SERIES		CFC (Normally Open)				CBC (Normally Closed)			
DESCRIPTION	Volts	Part Number	Typical Coil Data			Part Number	Typical Coil Data		
			DC Ohms	Watts	Amps		DC Ohms	Watts	Amps
1 Pole	24	CFC-717	7.1	9.6	0.930	CBC-701	7.1	7.7	0.837
	120	CFC-718	180	10.2	0.195	CBC-702	180	8.5	0.179
	208	CFC-719	600	9.5	0.097	CBC-703	600	7.6	0.087
	240	CFC-720	680	10.8	0.103	CBC-704	680	9.3	0.093
	277	CFC-721	1000	9.8	0.079	CBC-705	1000	8.0	0.070
	480	CFC-722	2700	11.8	0.057	CBC-706	2700	9.4	0.046
	12 (DC)	CFC-731	27	5.2	0.436	CBC-719	27	5.3	0.441
	24 (DC)	CFC-723	111	5.2	0.217	CBC-707	111	5.2	0.217
	2 Pole	24	CFC2-726	2.8	22.2	2.310	CBC2-315	2.8	17.0
120		CFC2-727	66	21.6	0.448	CBC2-309	66	17.8	0.408
208		CFC2-728	165	23.9	0.280	CBC2-316	165	20.2	0.265
240		CFC2-729	260	18.9	0.202	CBC2-306	260	15.4	0.182
277		CFC2-730	430	18.4	0.164	CBC2-317	430	14.5	0.145
480		CFC2-731	1100	21.0	0.104	CBC2-313	1100	16.6	0.094
12 (DC)		CFC2-741	10	13.8	1.153	CBC2-318	10	14.3	1.194
24 (DC)		CFC2-733	40	13.6	0.570	CBC2-319	40	13.6	0.570
3 Pole		24	CFC3-707	1.4	47.0	5.060	CBC3-307	1.4	40.0
	120	CFC3-708	23	39.0	0.924	CBC3-304	23	33.0	0.850
	208	CFC3-709	100	26.0	0.388	CBC3-308	100	23.0	0.345
	240	CFC3-710	110	27.7	0.361	CBC3-306	110	24.0	0.321
	277	CFC3-711	150	31.5	0.327	CBC3-309	150	26.9	0.294
	480	CFC3-712	440	28.8	0.185	CBC3-305	440	24.2	0.162
	12 (DC)	CFC3-720	10	13.5	1.127	CBC3-310	10	13.4	1.121
	24 (DC)	CFC3-721	40	13.3	0.555	CBC3-311	40	13.4	0.558

ELECTRICAL RATINGS	GENERAL PURPOSE 0.7/0.8 UL Power Factor						DC			Tungsten Lamp/60 Hz	AC MOTOR LOAD				
	Volts	120	208	240	277	480	600	1-48	120	240	120	1 Phase		3 Phase	
SERIES		60 Hz Amps						DC Amps			Amps	KW	Hp	Hp	Hp
CFC 100 (Normally Open)		100	100	100	100	100	100	100	50	30	100	12.0	7.5	10	20
CBC 100 (Normally Closed)		100	90	90	60	60	70	100	50	30	90	10.8	7.5	10	20

UL E35126  
SF LR-22416

**DURAKOOL Series DFC 150 Amps**



**1 POLE**  
Weight 2.5

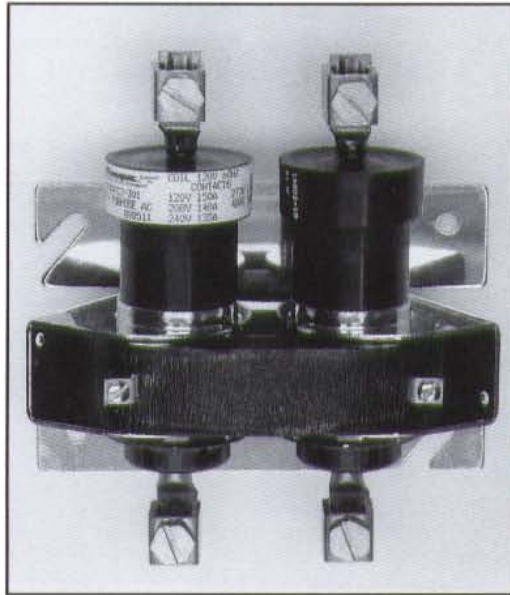

**2 POLE**  
Weight 4.5

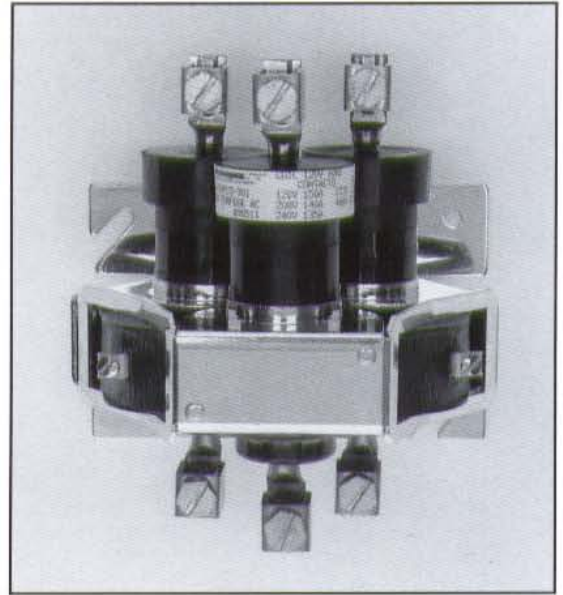

**3 POLE**  
Weight 7.0

**FRONT VIEW**

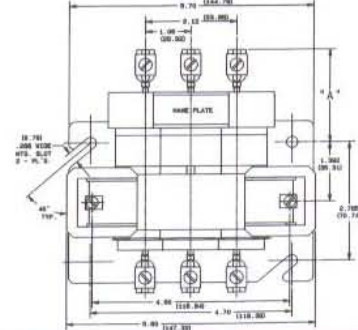
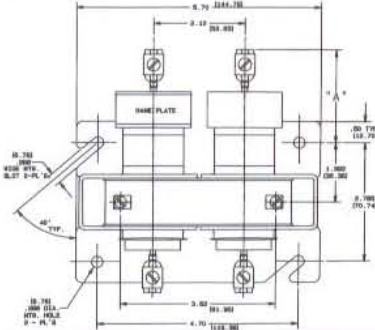
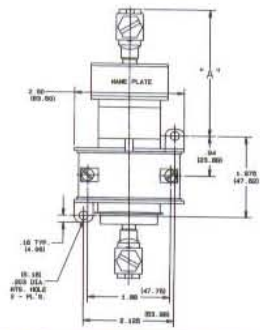

**SIDE VIEW**

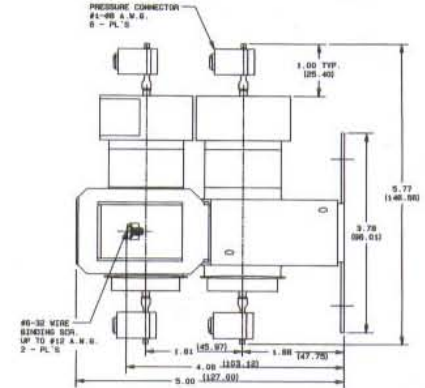
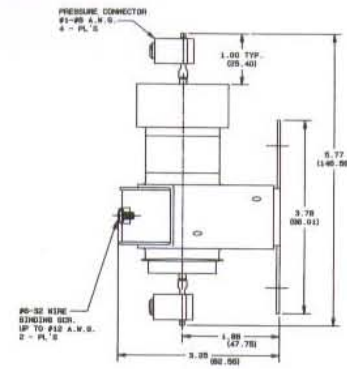
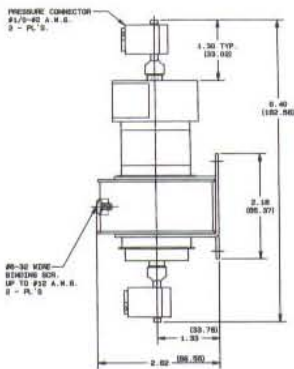

**DIMENSION "A"**

Hz	DFC		DFC2		DFC3	
	in.	mm	in.	mm	in.	mm
DC	2.69	68.3	2.23	56.6	2.23	56.6
50	2.92	74.2	2.46	62.5	2.46	62.5
50/60	2.96	75.2	2.50	63.5	2.46	62.5
60	2.96	75.2	2.50	63.5	2.46	62.5

## **DURAKOOL** Series DFC 150 Amps

Because of their virtually silent operation, Durakool contactors are the right solution for power switching in theaters, hospitals, nursing homes, and other "quiet zone" applications.

The normally open DFC contactors are general purpose rated at 150 Amps. Their long-lasting mercury-to-tungsten contacts resist arcing erosion and can handle inductive, tungsten, and resistive loads.

### SPECIFICATIONS

(see pages 3-5 for other specifications)

<b>Maximum Time:</b>	<b>Operate</b>	<b>Release</b>
	90 ms	140 ms
<b>Contact Bounce, Release:</b>	Allowed	
<b>Recommended DC Load Polarity:</b>	Top Connector Negative	
<b>Load Connectors:</b>	Pressure Connector #1/0-#2 AWG Cu.	
<b>Coil Terminals:</b>	#6-32 Wire Binding Screw, Max. #12 AWG Cu.	
<b>Breakdown Voltage:</b>	5000 VRMS/Min. Across Contacts	

TYPE/SERIES		DFC 150 Amps			
DESCRIPTION	Volts	Part Number	Typical Coil Data		
			DC Ohms	Watts	Amps
1 Pole Normally Open	24	DFC-307	7.1	8.2	0.815
	120	DFC-301	180	8.8	0.171
	208	DFC-304	600	8.0	0.086
	240	DFC-303	680	9.4	0.088
	277	DFC-305	1000	8.0	0.068
	480	DFC-306	2700	10.4	0.044
	12 (DC)	DFC-313	27	5.3	0.446
	24 (DC)	DFC-310	111	5.2	0.219
2 Pole Normally Open	24	DFC2-307	2.8	19.1	1.990
	120	DFC2-301	66	18.2	0.385
	208	DFC2-304	165	21.5	0.251
	240	DFC2-303	260	16.2	0.174
	277	DFC2-305	430	15.3	0.143
	480	DFC2-306	1100	17.3	0.091
	12 (DC)	DFC2-313	10	14.4	1.205
	24 (DC)	DFC2-310	40	13.7	0.572
3 Pole Normally Open	24	DFC3-307	0.7	46.0	4.900
	120	DFC3-301	18	42.9	0.968
	208	DFC3-304	50	35.2	0.482
	240	DFC3-303	69	36.2	0.425
	277	DFC3-305	110	32.5	0.330
	480	DFC3-306	276	40.2	0.222
	12 (DC)	DFC3-313	10	13.3	1.113
	24 (DC)	DFC3-310	40	13.2	0.552

ELECTRICAL RATINGS	GENERAL PURPOSE 0.7/0.8 UL Power Factor						DC			Tungsten Lamp/60 Hz	
	Volts	120	208	240	277	480	600	1-48	120	240	120
SERIES	60 Hz Amps						DC Amps			Amps KW	
	DFC 150 (Normally Open)	150	140	135	130	120	120	150	70	50	120

UL E35126  
LR-22416



## DURAKOOL Gold Label Series 35 & 50 Amps

Durakool Gold Label 35 and 50 Amp models (normally open) are economical, special purpose contactors developed to handle resistive loads over millions of switching cycles. They have been used successfully in commercial cooking equipment, plastics machinery, process heating controls, comfort heating and lighting control applications.

As in all Durakool contactors, the liquid contact action of mercury switching is far superior to conventional mechanical contactors, offering significantly longer life. Gold Label contactors operate dependably in harsh industrial/commercial environments without special protection and do not require sophisticated equipment for troubleshooting.

### SPECIFICATIONS

(see pages 3-5 for other specifications)

Maximum Time:	Operate	Release
	70 ms	90 ms
Contact Bounce, Release:	None	
Recommended DC Load Polarity:	Top Connector Negative	
Load Connectors:	Pressure Connector #4-14 AWG Cu.	
Coil Terminals:	#6-32 Wire Binding Screw, Max. #12 AWG Cu.	
Breakdown Voltage:	2000 VRMS/Min. Across Contacts	

TYPE/SERIES	Gold Label (35 Amps)							Gold Label (50 Amps)						
	Resistive Part Number	Motor Rated Part Number	Typical Coil Data				Resistive Part Number	Typical Coil Data						
DESCRIPTION	Volts		DC	Ohms	Watts	Amps	V.A.	DC	Ohms	Watts	Amps	V.A.		
1 Pole (Normally Open)	24	1035A24AC	1M35A24AC	40	2.80	0.233	5.59	1050A24AC	40	2.74	0.229	5.50		
	120	1035A120AC	1M35A120AC	902	3.69	0.057	6.84	1050A120AC	902	3.57	0.056	6.72		
	208	1035A208AC	1M35A208AC	3100	3.46	0.030	6.24	1050A208AC	3100	3.35	0.029	6.03		
	240	1035A240AC	1M35A240AC	3700	3.14	0.025	6.00	1050A240AC	3700	3.02	0.024	5.76		
	277	1035A277AC	1M35A277AC	5410	3.42	0.022	6.09	1050A277AC	5410	3.28	0.021	5.82		
	480	1035A480AC	1M35A480AC	15000	3.49	0.013	6.24	1050A480AC	15000	3.42	0.012	5.76		
	12 <sub>(DC)</sub>	1035A12DC	1M35A12DC	57	2.50	0.210	—	1050A12DC	40	3.47	0.288	—		
	24 <sub>(DC)</sub>	1035A24DC	1M35A24DC	230	2.50	0.104	—	1050A24DC	230	2.50	0.104	—		
	2 Pole (Normally Open)	24	2035A24AC	2M35A24AC	15	5.10	0.529	12.69	2050A24AC	15	5.10	0.519	12.47	
120		2035A120AC	2M35A120AC	350	7.10	0.130	15.60	2050A120AC	350	7.00	0.129	15.48		
208		2035A208AC	2M35A208AC	960	7.00	0.075	15.60	2050A208AC	960	6.90	0.074	15.39		
240		2035A240AC	2M35A240AC	1520	5.70	0.055	13.20	2050A240AC	1520	5.50	0.055	13.20		
277		2035A277AC	2M35A277AC	2300	5.70	0.045	12.47	2050A277AC	2300	5.30	0.044	12.19		
480		2035A480AC	2M35A480AC	5600	5.80	0.029	13.92	2050A480AC	5600	5.80	0.027	12.96		
12 <sub>(DC)</sub>		2035A12DC	2M35A12DC	24	6.00	0.500	—	2050A12DC	24	6.00	0.500	—		
24 <sub>(DC)</sub>		2035A24DC	2M35A24DC	90	6.40	0.266	—	2050A24DC	90	6.40	0.266	—		
3 Pole (Normally Open)		24	3035A24AC	3M35A24AC	5	11.10	1.270	30.48	3050A24AC	6	7.20	0.889	21.34	
	120	3035A120AC	3M35A120AC	135	9.20	0.220	26.40	3050A120AC	135	9.10	0.219	26.28		
	208	3035A208AC	3M35A208AC	480	8.70	0.111	23.09	3050A208AC	480	9.00	0.114	23.71		
	240	3035A240AC	3M35A240AC	520	9.20	0.109	26.16	3050A240AC	520	9.00	0.108	25.92		
	277	3035A277AC	3M35A277AC	830	8.10	0.081	22.44	3050A277AC	830	7.80	0.079	21.88		
	480	3035A480AC	3M35A480AC	2100	9.40	0.055	26.40	3050A480AC	2100	9.40	0.055	26.40		
	12 <sub>(DC)</sub>	3035A12DC	3M35A12DC	12.8	11.20	0.938	—	3050A12DC	12.8	10.70	0.889	—		
	24 <sub>(DC)</sub>	3035A24DC	3M35A24DC	51	11.30	0.470	—	3050A24DC	59.4	9.70	0.404	—		

ELECTRICAL RATINGS	GENERAL PURPOSE 0.7/0.8 UL Power Factor						DC			Tungsten Lamp/60 Hz	AC MOTOR LOAD			
							1-48	120	240	120	3 Phase			
Volts	120	208	240	277	480	600				120	120	240	480	
SERIES	60 Hz AC Amps						DC Amps			Amps	KW	Hp	Hp	Hp
GL 35A (Normally Open)	35	35	35	35	35	35	35	17	10	35	4.2	3.0	7.5	10.0
GL 50A (Normally Open)	35	50	50	50	50	50	50	25	15	50	6.0			

UL E35126  
SF LR-22416

## DURAKOOL Series 2030, 3030 30 Amps

These Durakool 2 pole (2030) and 3 pole (3030) contactors (normally open), are designed for resistive loads typically found in heating and processing equipment such as ovens, fryers, and dishwashers. They feature quiet operation and rapid on/off cycling. They are a practical replacement for mechanical contactors, providing a long service life and reliable operation even in hostile environments. They will fit in the same space as most mechanical contactors. Easy to install, the 2030/3030 contactors have a standard DP mounting footprint. The terminal screws all face forward for easy connection of leads to contacts.

### SPECIFICATIONS

(see pages 3-5 for other specifications)

Maximum Time:	Operate 50 ms, Max.	Release 70 ms, Max.
Contact Bounce, Release:	None	
Recommended DC Load Polarity:	Top Connection Negative	
Breakdown Voltage:	Contact to Ground: 5000 VRMS/Min.	
Weight:	2.0 lbs.	

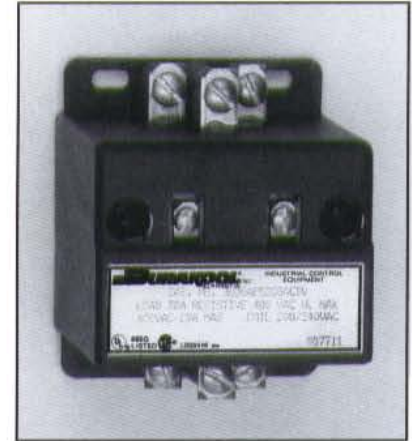

TOP VIEW

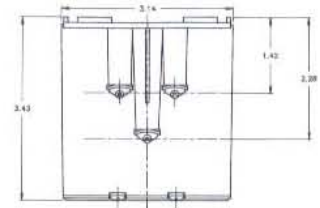

FRONT VIEW

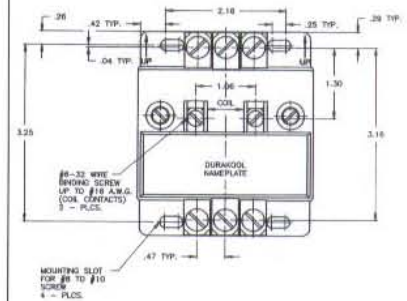

SIDE VIEW

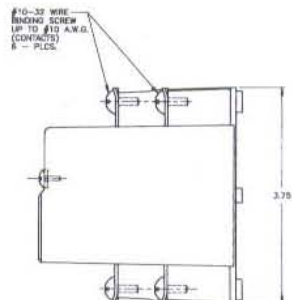

TYPE/SERIES	2030/3030 30 Amps		Typical Coil Data			
DESCRIPTION	Part Number	DC Ohms	Watts	Amps	V.A.	
2 POLE Normally Open	24 Volts	2030APS24AC	20	4.52	0.456	10.94
	120	2030APS120AC	340	6.45	0.121	14.52
	208	2030APS208AC	1251	5.48	0.055	11.44
	240	2030APS240AC	1420	6.68	0.059	14.16
	480	2030APS480AC	5700	6.80	0.028	13.44
	12 (DC)	2030APS12DC	24.5	5.80	0.489	5.87
	24 (DC)	2030APS24DC	96	5.80	0.240	5.76
3 Pole Normally Open	24	3030APS24AC	13.8	4.60	0.510	12.24
	120	3030APS120AC	340	4.80	0.106	12.72
	208	3030APS208AC	1251	4.98	0.055	11.44
	208	3030APS208ACDV	1251	4.98	0.055	11.44
	240		1251	6.50	0.062	14.88
	240	3030APS240AC	1420	4.80	0.062	12.48
	277	3030APS277AC	1730	4.70	0.044	12.19
	480	3030APS480AC	5700	5.26	0.025	12.00
	12 (DC)	3030APS12DC	24.5	5.80	0.489	5.87
	24 (DC)	3030APS24DC	96	6.00	0.250	6.00

ELECTRICAL RATINGS		RESISTIVE LOAD 60 Hz Amps						DC Amps	Tungsten 120
SERIES	Volts	120	208	240	277	480	600	1-48	60 Hz
2030, 3030		30	30	30	30	30	30	30	25



## DURAKOOL Series 2M30, 3M30 30 Amps

These Durakool contactors are especially designed for motor control circuits. They are UL rated for 240 volts, 3-phase motor applications. These 30 Amp contactors are ruggedly constructed to provide reliable, quiet operation over many switching cycles. With the same footprint as a DP mechanical contactor, they are a practical replacement, especially in hostile environments where their hermetic seal makes them immune to dust, dirt, and oil. All terminal screws face forward for easy installation.

### SPECIFICATIONS

(see pages 3-5 for other specifications)

Maximum Time: Operate 50 ms, Max. Release 70 ms, Max.

Contact Bounce, Release: None

Recommended

DC Load Polarity: Top Connection Negative

Breakdown Voltage:

Contact to Ground: 5000 VRMS/Min.

Weight: 2.0 lbs.



TYPE/SERIES		2M30/3M30 30 Amps		Typical Coil Data			
DESCRIPTION		Part Number	DC Ohms	Watts	Amps	V.A.	
2 POLE Normally Open	Volts						
	24	2M30APS24AC	20	4.52	0.456	10.94	
	120	2M30APSI20AC	340	6.45	0.121	14.52	
	208	2M30APS208AC	1251	5.48	0.055	11.44	
	240	2M30APS240AC	1420	6.68	0.059	14.16	
	480	2M30APS480AC	5700	6.80	0.028	13.44	
	12 (DC)	2M30APSI2DC	24.5	5.80	0.489	5.87	
24 (DC)	2M30APS24DC	96	5.80	0.240	5.76		
3 Pole Normally Open	24	3M30APS24AC	13.8	4.60	0.510	12.24	
	120	3M30APSI20AC	340	4.80	0.106	12.72	
	208	3M30APS208AC	1251	4.98	0.055	11.44	
	208	3M30APS208ACDV	1251	4.98	0.055	11.44	
	240		1251	6.50	0.062	14.88	
	240	3M30APS240AC	1420	4.80	0.062	12.48	
	277	3M30APS277AC	1730	4.70	0.044	12.19	
	480	3M30APS480AC	5700	5.26	0.025	12.00	
	12 (DC)	3M30APSI2DC	24.5	5.80	0.489	5.87	
	24 (DC)	3M30APS24DC	96	6.00	0.250	6.00	

ELECTRICAL RATINGS	60 Hz					DC	
	Volts	120	208	240	277	480	48
Resistive		30	30	30	30	30	30
General Purpose		30	30	30	20	20	—
Motor Load (Hp) 3-pole		1.5	1.5	3.0	3.0	3.0	—
Full Load Amps		—	—	14.8	—	—	—
Locked Rotor Amps		—	—	89.0	—	—	—

UL E35126  
SP LR-22416

### TOP VIEW

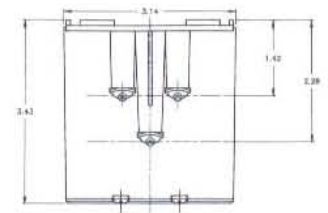

### FRONT VIEW

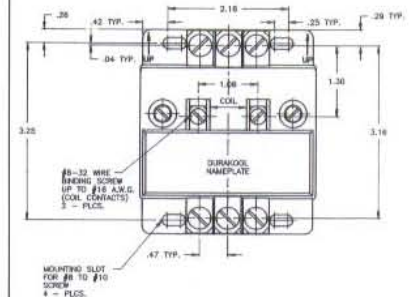

### SIDE VIEW

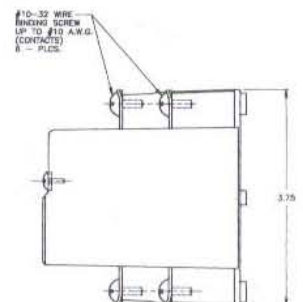

Not all part numbers are shown within a series. For additional information, please contact Customer Support at (888) 847-6552 or (574) 264-6099, Ext. 501 or 503.

**DURAKOOL Series 60APS 60 Amps**



**1 POLE**  
Weight 1.0 lbs.

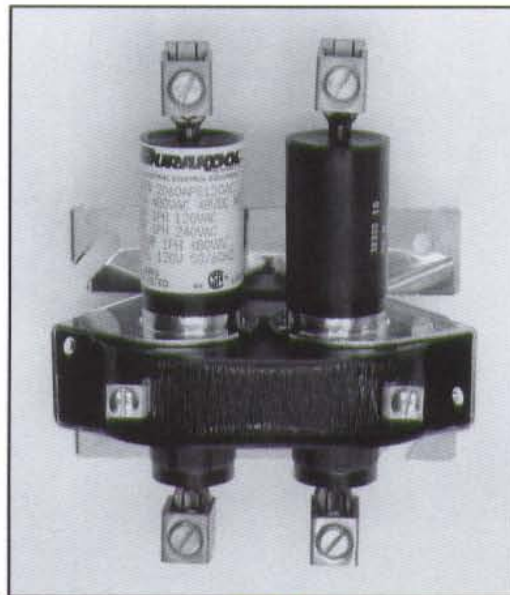

**2 POLE**  
Weight 2.0 lbs.

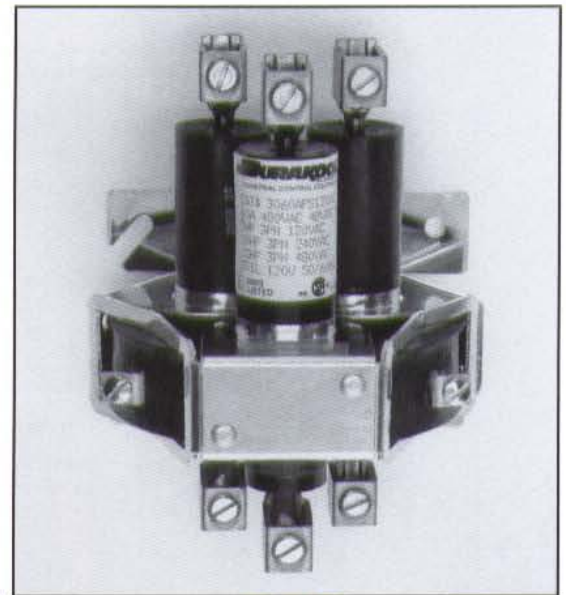

**3 POLE**  
Weight 3.0 lbs.

**FRONT VIEW**

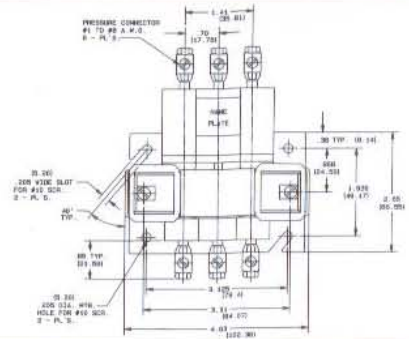
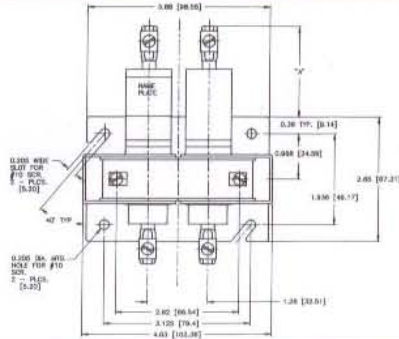
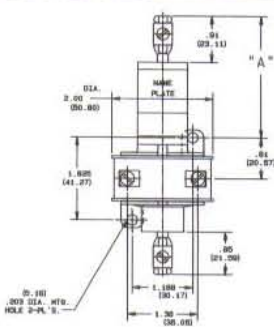

**SIDE VIEW**

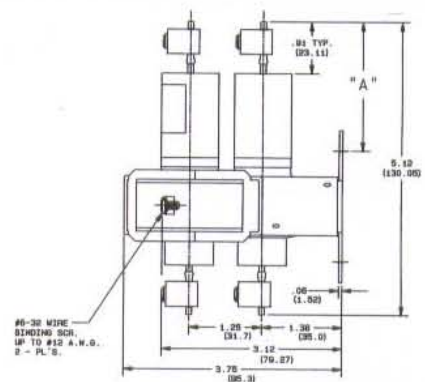
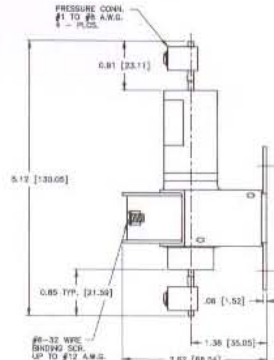
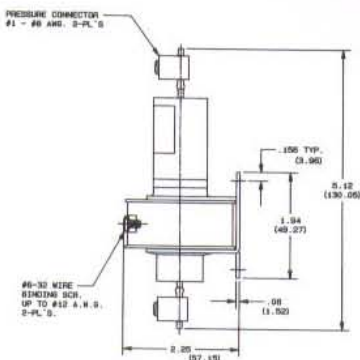

**DIMENSION "A"**

Hz	1 Pole		2 Pole		3 Pole	
	in.	mm	in.	mm	in.	mm
DC	2.32	58.9	2.17	55.1	2.17	55.1
50	2.41	61.2	2.26	57.4	2.26	57.4
50/60	2.41	61.2	2.26	57.4	2.26	57.4
60	2.41	61.2	2.26	57.4	2.26	57.4



## **DURAKOOL** Series 60APS 60 Amps

The Durakool 60 Amp high performance contactor (normally open) is designed for resistive loads typical in industrial ovens, food processing and laboratory equipment, lighting and computer power supplies, plus medical and communications equipment.

The 60 Amp contactor is UL/CSA listed for general purpose, inductive, and tungsten, as well as resistive loads. The contactor features long life, quiet operation, and rapid on/off cycling. Since it is hermetically sealed, it is a practical replacement, especially in hostile environments.



### SPECIFICATIONS

(see pages 3-5 for other specifications)

Maximum Time:	Operate	Release
	70 ms, Max.	90 ms, Max.
Contact Bounce:	None	
Recommended		
DC Load Polarity:	Top Connection Negative	
Breakdown Voltage:		
Contact to Contact:	2000 VRMS/Min.	
Contact to Ground:	5000 VRMS/Min.	

TYPE/SERIES		60APS 60 Amps				
DESCRIPTION		Part Number	Typical Coil Data			
Volts			DC Ohms	Watts	Amps	V.A.
1 Pole (Normally Open)	24	1060APS24AC	40	2.60	0.235	5.64
	120	1060APS120AC	902	3.47	0.055	6.60
	240	1060APS240AC	3700	3.40	0.026	6.24
	480	1060APS480AC	15000	3.54	0.012	5.76
	12 (DC)	1060APS12DC	40	3.64	0.293	3.52
	24 (DC)	1060APS24DC	230	3.48	0.146	3.50
2 Pole (Normally Open)	24	2060APS24AC	15	5.20	0.525	12.60
	120	2060APS120AC	350	7.46	0.133	15.96
	240	2060APS240AC	1520	6.18	0.056	13.44
	480	2060APS480AC	5600	6.47	0.027	12.96
	12 (DC)	2060APS12DC	24	6.10	0.506	6.07
	24 (DC)	2060APS24DC	90	6.00	0.253	6.07
3 Pole (Normally Open)	24	3060APS24AC	4.5	3.65	0.492	11.81
	120	3060APS120AC	122	9.54	0.224	26.88
	240	3060APS240AC	470	9.47	0.110	26.40
	480	3060APS480AC	1900	10.12	0.055	26.40
	12 (DC)	3060APS12DC	12.8	10.10	0.866	10.39
	24 (DC)	3060APS24DC	46	11.10	0.461	11.06

ELECTRICAL RATINGS	60 Hz					DC		
	Volts	120	208	240	277	480	48	120
Resistive		60	60	60	60	60	60	30
General Purpose		60	60	60	60	60	—	—
Tungsten (1 Pole)		60	60	60	60	35	60	30
Motor Load								
1 Phase (Hp)		3.0	3.0	5.0	5.0	7.5	—	—
3 Phase (Hp)		5.0	5.0	10.0	10.0	15.0	—	—

 **E61703**  
 **LR-22416**

# DURAKOOL High Voltage Contactors (2500-3500 Volts at 10 Amps AC & 4000 Volts at 8 Amps AC)

With 10 Amp ratings and several standard options, Durakool high voltage contactors are a versatile choice for UV curing lamp controls and panel safety switching and other high voltage loads. The 2500 VAC or 3500 VAC rated models, single-pole are made either normally open or normally closed. Terminals come with standard pressure connectors or 5000 VAC rated leads. HV contactors are compact for easy panel mounting, and provide mercury switching dependability.

### SPECIFICATIONS

(see pages 3-5 for other specifications)

Maximum Time: Operate Release  
 Normally Open 90 ms, Max. 140 ms, Max.  
 Normally Closed 200 ms, Max. 100 ms, Max.  
 Contact Bounce, Release: Allowed on normally open models  
 Recommended DC Load Polarity: Top Connection Negative  
 Load Connectors: Pressure Connector #1-18 AWG Cu.  
 Coil Terminals: #6-32 Wire Binding Screw, Max. #12 AWG Cu.  
 Breakdown Voltage: 5000 VRMS/Min. Across Contacts  
 Weight: 1.5 lbs.



**BLACK LEAD**

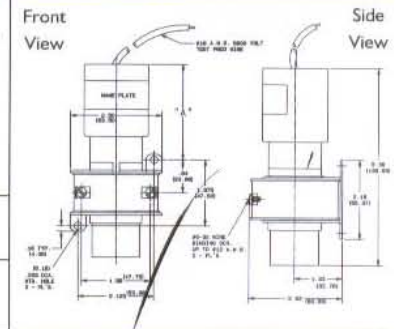

**TERMINAL**

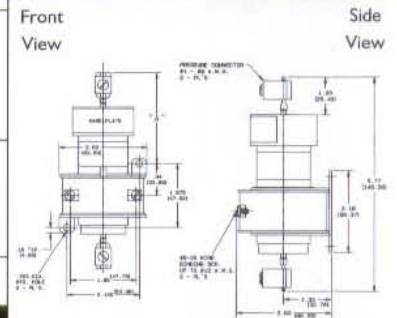

TYPE/SERIES	DESCRIPTION	Volts	Part Number	Hz	Typical Coil Data DC Ohms	Watts	Amps	
Normally Open	2500 Terminal	120	CFH-302	50/60	180	9.0	0.174	
		240	CFH-303	50/60	680	9.3	0.089	
	2500 Black Leads	120	CFH-216	50/60	180	9.0	0.174	
		240	CFH-215	50/60	680	9.3	0.089	
		24 (DC)	CFH-226	—	111	5.2	0.217	
		48 (DC)	CFH-238	—	440	4.8	0.100	
	3500 Terminal & 4000 Terminal	120	CFCH-397 & CFCH-418	50/60	180	9.0	0.174	
		240	CFCH-387 & CFCH-419	50/60	680	9.3	0.089	
		24 (DC)	CFCH-396 & CFCH-420	—	111	5.2	0.217	
	Normally Closed	2500 Terminal	120	CBH-302	60	180	8.5	0.179
			120	CBH-305	50	180	9.8	0.196
			240	CBH-303	60	680	9.3	0.093
2500 Black Leads		120	CBH-225	50	180	9.8	0.196	
		120	CBH-218	60	180	8.5	0.179	
		240	CBH-222	50	680	9.3	0.089	
		240	CBH-215	60	680	9.3	0.093	
		24 (DC)	CBH-221	60	111	5.2	0.217	
3500 Terminal		120	CBCH-333	50/60	180	8.5	0.179	
		210	CBCH-337	50/60	600	7.4	0.086	
		240	CBCH-335	60	680	9.3	0.093	
		48 (DC)	CBCH-339	—	440	4.8	0.100	

DIMENSION "A"						
Hz	CFH, CFCH w/leads or terminals		CBH, CBCH with terminals		CBH, CBCH with leads	
	in.	mm	in.	mm	in.	mm
DC	2.39	60.7	2.04	57.82	2.10	53.34
50	2.62	66.5	2.02	51.31	2.08	52.83
50/60	2.66	67.5	2.02	51.31	2.08	52.83
60	2.66	67.6	1.92	43.77	1.98	50.29

DIMENSION "B" (Overall Length)					
Hz	CFH,CFCH		CBH,CBCH		
	in.	mm	in.	mm	
w/terminals	5.77	146.6	5.98	151.9	
w/leads	5.38	136.7	5.75	146.1	

Not all part numbers are shown within a series. For additional information, please contact Customer Support at (888) 847-6552 or (574) 264-6099, Ext. 501 or 503.

## **DURAKOOL** Worldwide Distributors

### NORTH AMERICA

#### Northwest

*Washington*  
Temco-Aztec  
(425) 481-6150

*Oregon*  
Temco-Aztec  
(503) 626-6643

#### West Coast

*California*  
Don Pass & Assoc.  
(925) 443-9040

Campbell-George Co.  
(650) 654-5000

C&W - Acort Sales  
(818) 700-2991

#### Western States

*Arizona*  
H-D Associates  
(480) 784-2944

#### Texas

Dawson and Associates  
(281) 272-1717

Heat Source  
(281) 272-1190

*Utah*  
Heatcon, Inc.  
(206) 575-0815

#### Central-Midwest

*Illinois*  
Power Components  
(800) 221-9257

*Indiana*  
Power Components  
(800) 221-9257

*Michigan*  
North Coast Components  
(616) 379-4100

*Minnesota*  
Volco Electric  
(925) 933-4671

*Missouri*  
Richard Green  
(314) 423-8989

#### Ohio

Orr & Assoc.  
(800) 837-2700

*Wisconsin*  
Power Components  
(800) 221-9257

#### East Coast

*New York*  
International Sensors &  
Controls  
(203) 270-9391

*New Jersey*  
Riverside Components  
(800) 642-7107

#### Southeast

Beacon Industrial Group  
(800) 642-7107

#### Canada

Davis Controls  
(905) 829-2000

**Technical and Sales  
Support US &  
Canada**

**574 264-6099  
Ext. 501 & 503**

**Fax 574 293-8013**

**Outside of US &  
Canada**

**574 264-6099  
Ext. 501 & 503**

**Fax 574 293-8013**

### ASIA

Japan  
Sankyo International  
81-35-821-2511

Taiwan  
JinZon Enterprises  
886-02-271-11093

### EUROPE

Germany  
Endrich Bauelemente Vertriebs  
49-745-260-070

Italy  
Fancos SPA  
39-02-95898034

Sweden  
Acte Sweden AB  
46-84-452-800

United Kingdom  
Willow Technologies  
44-1342-835234

### DOWN UNDER

Australia  
Universal Components  
29-638-5388

New Zealand  
Soanar Technologies  
64-9-262-2461

American Electronic Components specializes in the design and manufacture of electronic, electrical, and mechanical components. AEC's products are shipped worldwide for a diverse set of markets which include automotive, consumer electronics, appliance, industrial control, and outdoor power equipment manufacturers. For more information, contact AEC at 219-264-1116.



### ◀ Sensors

Hall Effect, Variable Reluctance, and Accelerometer Sensors for a variety of automotive and other applications.

### Relays ▶

Hermetically sealed high power relays 10-150 Amps for general and high voltage use.



### ◀ Switches

Hermetically sealed tilt and tip-over switches for appliance, automotive, security, and safety use.



### Electromechanical ▶

Starter solenoids for outdoor power equipment and solenoids for automotive seatbelt retractors.



Local Representative:



23590 County Road 6  
Elkhart, IN 46514  
(574) 264-1116  
Fax: (574) 293-8013  
[www.aecensors.com](http://www.aecensors.com)