

Features

1 & 2 pole relay interface modules, screw terminal socket, 15.8 mm wide.

Ideal interface for PLC and electronic systems

4C.01 - 1 Pole 16 A

4C.02 - 2 Pole 8 A

- AC coils or DC coils
- Instant ejection of relay using plastic retaining clip
- Supply status indication and coil suppression module as standard
- Identification label
- UL Listing (certain relay/socket combinations)
- 35 mm rail (EN 50022) mounting

4C.01 / 4C.02
Screw terminal



4C.01



- 1 pole, 16 A
- Screw terminal connection
- 35 mm rail (EN 50022) mounting

4C.02



- 2 pole, 8 A
- Screw terminal connection
- 35 mm rail (EN 50022) mounting

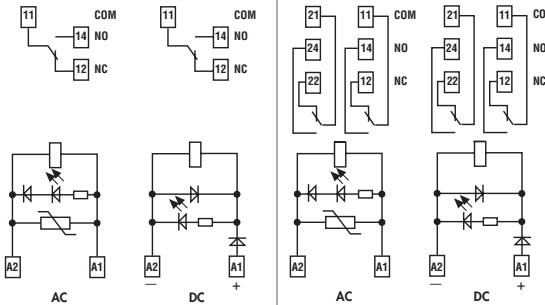

For outline drawing of 4C.01/02 see page 5

Contact specification			
Contact configuration		1 CO (SPDT)	2 CO (DPDT)
Rated current/Maximum peak current	A	16/25	8/15
Rated voltage/Maximum switching voltage	V AC	250/440	250/440
Rated load AC1	VA	4000	2000
Rated load AC15 (230 V AC)	VA	750	350
Single phase motor rating (230 V AC)	kW	0.55	0.37
Breaking capacity DC1: 30/110/220V	A	16/0.5/0.15	6/0.5/0.15
Minimum switching load	mW (V/mA)	300 (5/5)	300 (5/5)
Standard contact material		AgNi	AgNi
Coil specification			
Nominal voltage (U _N)	V AC (50/60 Hz)	12 - 24 - 110 - 120 - 230	12 - 24 - 110 - 120 - 230
	V DC	12 - 24 - 125	12 - 24 - 125
Rated power AC/DC	VA (50 Hz)/W	1.2/0.5	1.2/0.5
Operating range	AC	(0.8...1.1)U _N	(0.8...1.1)U _N
	DC	(0.73...1.1)U _N	(0.73...1.1)U _N
Holding voltage	AC/DC	0.8 U _N / 0.4 U _N	0.8 U _N / 0.4 U _N
Must drop-out voltage	AC/DC	0.2 U _N / 0.1 U _N	0.2 U _N / 0.1 U _N
Technical data			
Mechanical life AC/DC	cycles	10 · 10 ⁶	10 · 10 ⁶
Electrical life at rated load AC1	cycles	100 · 10 ³	100 · 10 ³
Operate/release time	ms	15/5 (AC) - 15/12 (DC)	10/3 (AC) - 10/10 (DC)
Insulation between coil and contacts (1.2/50 μs)	kV	6 (8 mm)	6 (8 mm)
Dielectric strength between open contacts	V AC	1000	1000
Ambient temperature range	°C	≤ 12A: -40...+70 / > 12A: -40...+50	-40...+70
Protection category		IP 20	IP 20
Approvals - relay (according to type)			

Features

1 & 2 pole relay interface modules, screwless terminal socket, 15.8 mm wide.

Ideal interface for PLC and electronic systems

4C.51 - 1 Pole 10 A

4C.52 - 2 Pole 8 A

- AC coils or DC coils
- Instant ejection of relay using plastic retaining clip
- Supply status indication and coil suppression module as standard
- Identification label
- UL Listing (certain relay/socket combinations)
- 35 mm rail (EN 50022) mounting

4C.51 / 4C.52
Screwless terminal



4C.51



- 1 pole, 10 A
- Screwless terminal connections
- 35 mm rail (EN 50022) mounting

4C.52



- 2 pole, 8 A
- Screwless terminal connections
- 35 mm rail (EN 50022) mounting

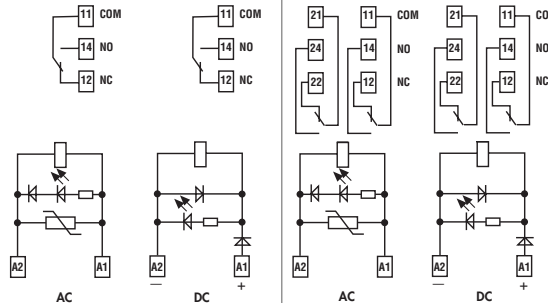

For outline drawing of 4C.51/52 see page 5

Contact specification			
Contact configuration		1 CO (SPDT)	2 CO (DPDT)
Rated current/Maximum peak current	A	10/20	8/15
Rated voltage/Maximum switching voltage	V AC	250/440	250/440
Rated load AC1	VA	2500	2000
Rated load AC15 (230 V AC)	VA	750	350
Single phase motor rating (230 V AC)	kW	0.55	0.37
Breaking capacity DC1: 30/110/220V	A	10/0.5/0.15	6/0.5/0.15
Minimum switching load	mW (V/mA)	300 (5/5)	300 (5/5)
Standard contact material		AgNi	AgNi
Coil specification			
Nominal voltage (U _N)	V AC (50/60 Hz)	12 - 24 - 110 - 120 - 230	12 - 24 - 110 - 120 - 230
	V DC	12 - 24 - 125	12 - 24 - 125
Rated power AC/DC	VA (50 Hz)/W	1.2/0.5	1.2/0.5
Operating range	AC	(0.8...1.1)U _N	(0.8...1.1)U _N
	DC	(0.73...1.1)U _N	(0.73...1.1)U _N
Holding voltage	AC/DC	0.8 U _N / 0.4 U _N	0.8 U _N / 0.4 U _N
Must drop-out voltage	AC/DC	0.2 U _N / 0.1 U _N	0.2 U _N / 0.1 U _N
Technical data			
Mechanical life AC/DC	cycles	10 · 10 ⁶	10 · 10 ⁶
Electrical life at rated load AC1	cycles	100 · 10 ³	100 · 10 ³
Operate/release time	ms	15/5 (AC) - 15/12 (DC)	10/3 (AC) - 10/10 (DC)
Insulation between coil and contacts (1.2/50 μs)	kV	6 (8 mm)	6 (8 mm)
Dielectric strength between open contacts	V AC	1000	1000
Ambient temperature range	°C	-25...+70	-25...+70
Protection category		IP 20	IP 20
Approvals - relay (according to type)			

Ordering information

Example: 4C series, 35 mm rail (EN 50022) mount screw terminal relay interface module, 1 CO (SPDT) 16 A contacts, 24 V DC coil, green LED + diode.

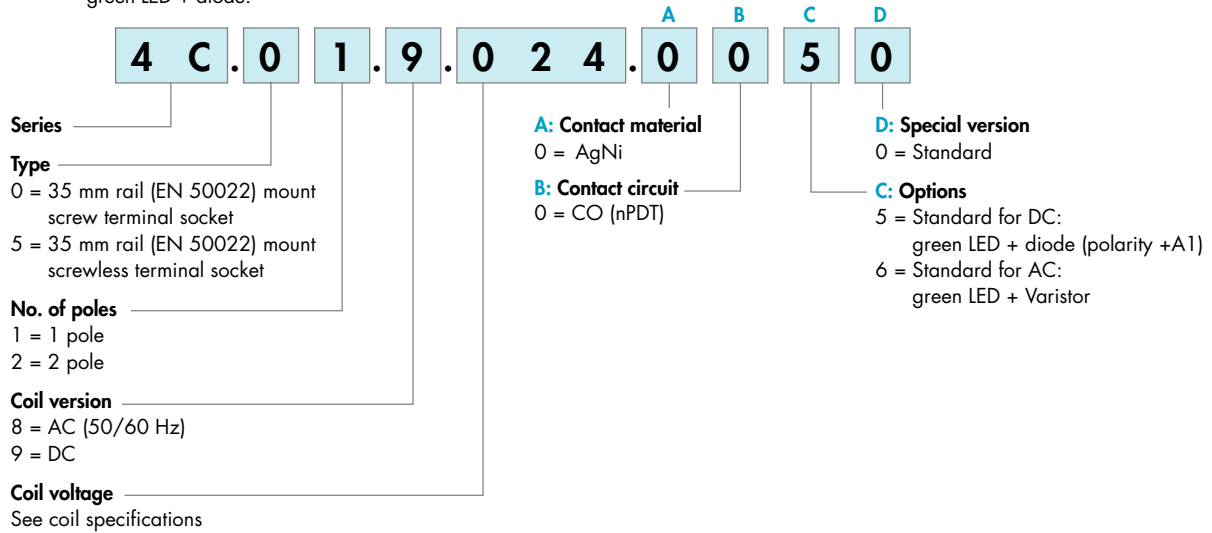

Technical data

Insulation						
Insulation according to EN 61810-1	insulation rated voltage	V	250	440		
	rated impulse withstand voltage	kV	4	4		
	pollution degree		3	2		
	overvoltage category		III	III		
Insulation between coil and contacts (1.2/50 μs)		kV	6 (8 mm)			
Dielectric strength between open contacts		V AC	1000			
Dielectric strength between adjacent contacts		V AC	2000			
Conducted disturbance immunity						
Burst (5...50)ns, 5 kHz, on A1 - A2			EN 61000-4-4	level 4 (4 kV)		
Surge (1.2/50 μs) on A1 - A2 (differential mode)			EN 61000-4-5	level 3 (2 kV)		
Other data						
Bounce time: NO/NC		ms	2/6 (4C.01/51)	1/4 (4C.02/52)		
Vibration resistance (10...150)Hz: NO/NC		g	20/12			
Power lost to the environment	without contact current	W	0.6			
	with rated current	W	1.6 (4C.01/51)	2 (4C.02/52)		
			4C.01/4C.02	4C.51/4C.52		
Wire strip length		mm	8			
Screw torque		Nm	0.5			
Max. wire size		solid cable	stranded cable	solid cable	stranded cable	
		mm ²	1x6/2x2.5	1x4/2x2.5	2x(0.2...1.5)	2x(0.2...1.5)
		AWG	1x10/2x14	1x12/2x14	2x(24...18)	2x(24...18)

Contact specification

F 4C - Electrical life (AC) v contact current
Types 4C.02/52

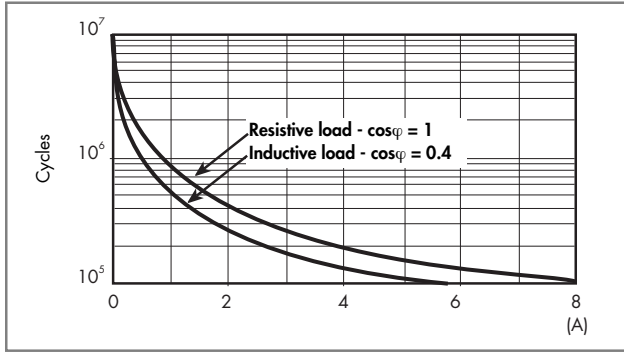

F 4C - Electrical life (AC) v contact current
Types 4C.01/51

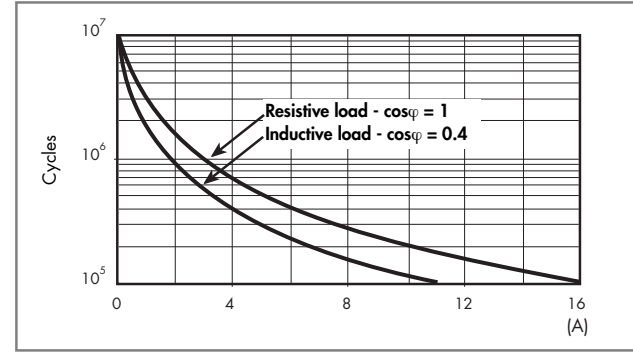

H 4C - Maximum DC1 breaking capacity

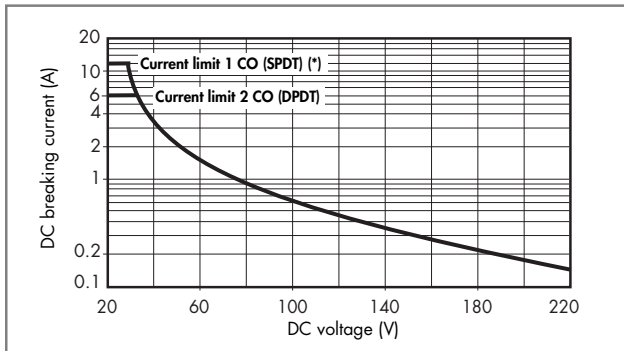

(*) Type 4C.01 = 12 A, Type 4C.51 = 10 A

- When switching a resistive load (DC1) having voltage and current values under the curve, an electrical life of $\geq 100 \cdot 10^3$ can be expected.
- In the case of DC13 loads, the connection of a diode in parallel with the load will permit a similar electrical life as for a DC1 load. Note: the release time for the load will be increased.

Coil specifications

DC coil data

Nominal voltage U_N V	Coil code	Operating range		Resistance R Ω	Rated coil consumption I at U_N mA
		U_{min} V	U_{max} V		
12	9.012	8.8	13.2	300	40
24	9.024	17.5	26.4	1200	20
125	9.125	91.2	137.5	32000	3.9

AC coil data

Nominal voltage U_N V	Coil code	Operating range		Resistance R Ω	Rated coil consumption I at U_N mA
		U_{min} V	U_{max} V		
12	8.012	9.6	13.2	80	90
24	8.024	19.2	26.4	320	45
110	8.110	88	121	6900	9.4
120	8.120	96	132	9000	8.4
230	8.230	184	253	28000	5

R 4C - DC coil operating range v ambient temperature

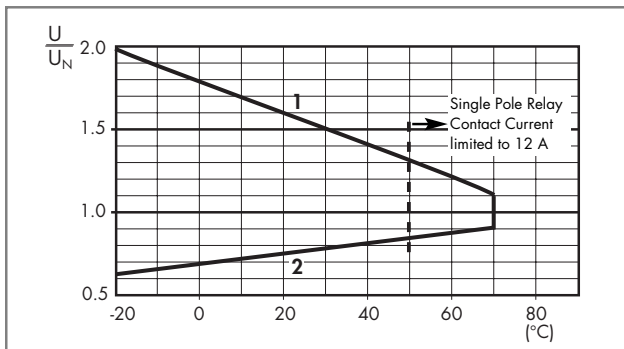

- 1 - Max. permitted coil voltage.
2 - Min. pick-up voltage with coil at ambient temperature.

R 4C - AC coil operating range v ambient temperature

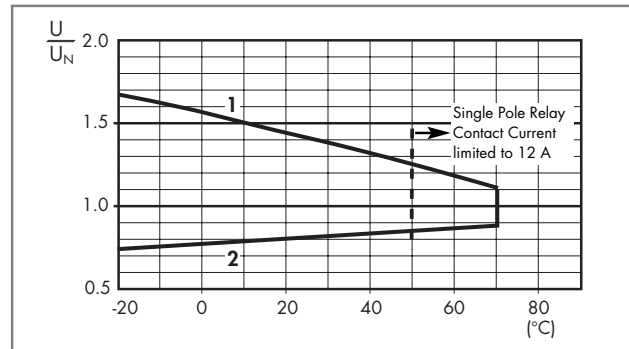

- 1 - Max. permitted coil voltage.
2 - Min. pick-up voltage with coil at ambient temperature.

----- Temperature limit for the single pole version under full 16 A contact current.

Combinations

Code	Type of socket	Type of relay	Module	Retaining clip
4C.01	97.01	46.61	99.02	097.01
4C.02	97.02	46.52	99.02	097.01
4C.51	97.51	46.61	99.02	097.01
4C.52	97.52	46.52	99.02	097.01

Certain relay/socket combinations

Outline drawing

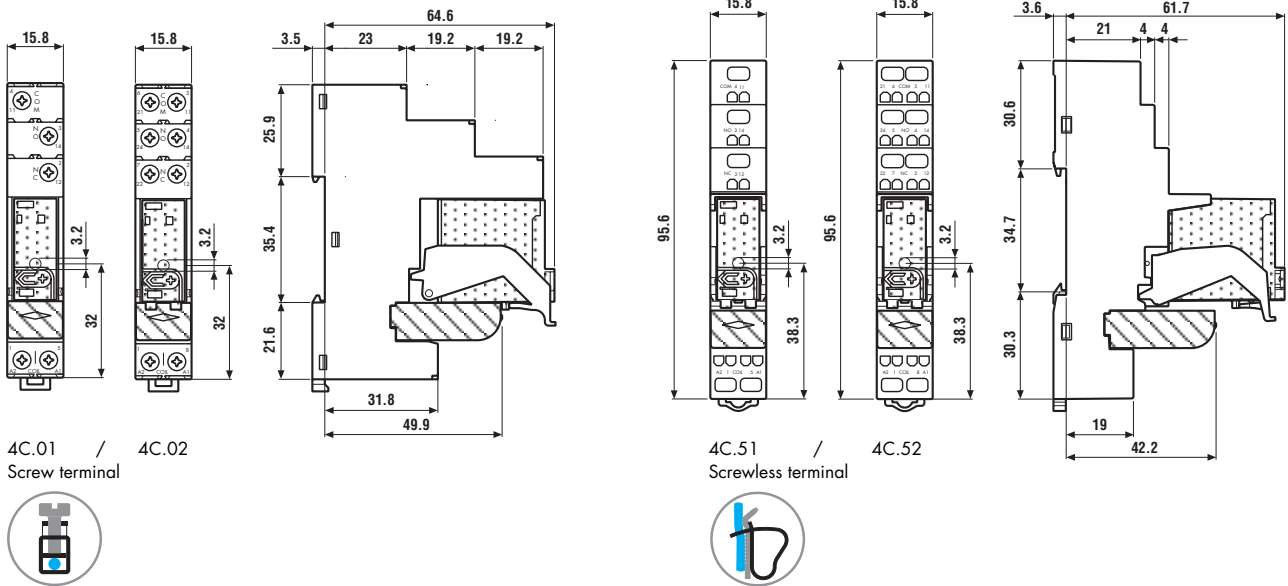

Accessories



8-way jumper link for 4C.01 and 4C.02	095.18 (blue)
Rated values	10 A - 250 V

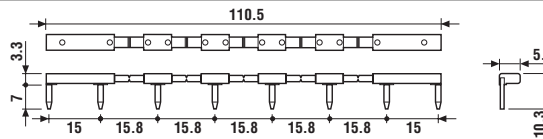

Sheet of marker tags , plastic, 72 tags, 6x12 mm	060.72
---	--------

Packaging code

How to code and identify retaining clip and packaging options for relay interface module.

Example:

4 C . 0 1 . 9 . 0 2 4 . 0 0 5 0 S P A

A Standard packaging
B Blister packaging

SP Plastic retaining clip

