

## Advantages of the 712 Alternating Relay

### The Complete System Solution!



Highest Grade  
Electronic Components  
RoHS Compliant.

The Model 712 series Alternating Relay is designed for duplex pumping systems where it is desirable to equalize pump run time. The solid state alternating circuit drives an internal electromechanical relay. A continuous power source and control switch are required.

The control switch (float, pressure or other isolated contact) is connected between the L1 terminal and the control terminal. Each time the control switch is opened the output contacts will change status. Indicator lights on the case show the internal relay status.

Setting the top toggle switch to Load 1 or Load 2 will lock the relay in position, preventing alternation.

UL Listed when 712 Relay  
and Octal Socket are Combined  
UL Approved for Field Replacement.

- Offers a "one stop solution" for your pump management system.
- Several configurations available to meet your individual needs.
- Switching capabilities up to 12 amps.
- Two LED status indicators; indicate status of the separate loads independently.
- Dual Voltage Coils eliminate the need to specify AC or DC (AC only for 240 volts).
- Only 36 mm's wide; does not take up any additional room on the DIN rail.
- Color and appearance designed for high visibility in all environments.
- Engineering availability allows for customized control system solutions.



See Section 3 p.14-16



**16-711C1  
FLANGE ADAPTER**



**16-711C4  
DIN RAIL ADAPTER**

**Load 1 Indicator**  
Indicates when Load 1 is Active.

**Load 2 Indicator**  
Indicates when Load 2 is Active.

**Top Toggle Switch**  
To Lock Load in Position.

**Industry Proven Power Relay Technology**  
12 Amp Relay with Dual Voltage Capability.

**Industry Standard 8 or 11 Pin Octal Socket Compatible**  
Easy Installation and Replacement.

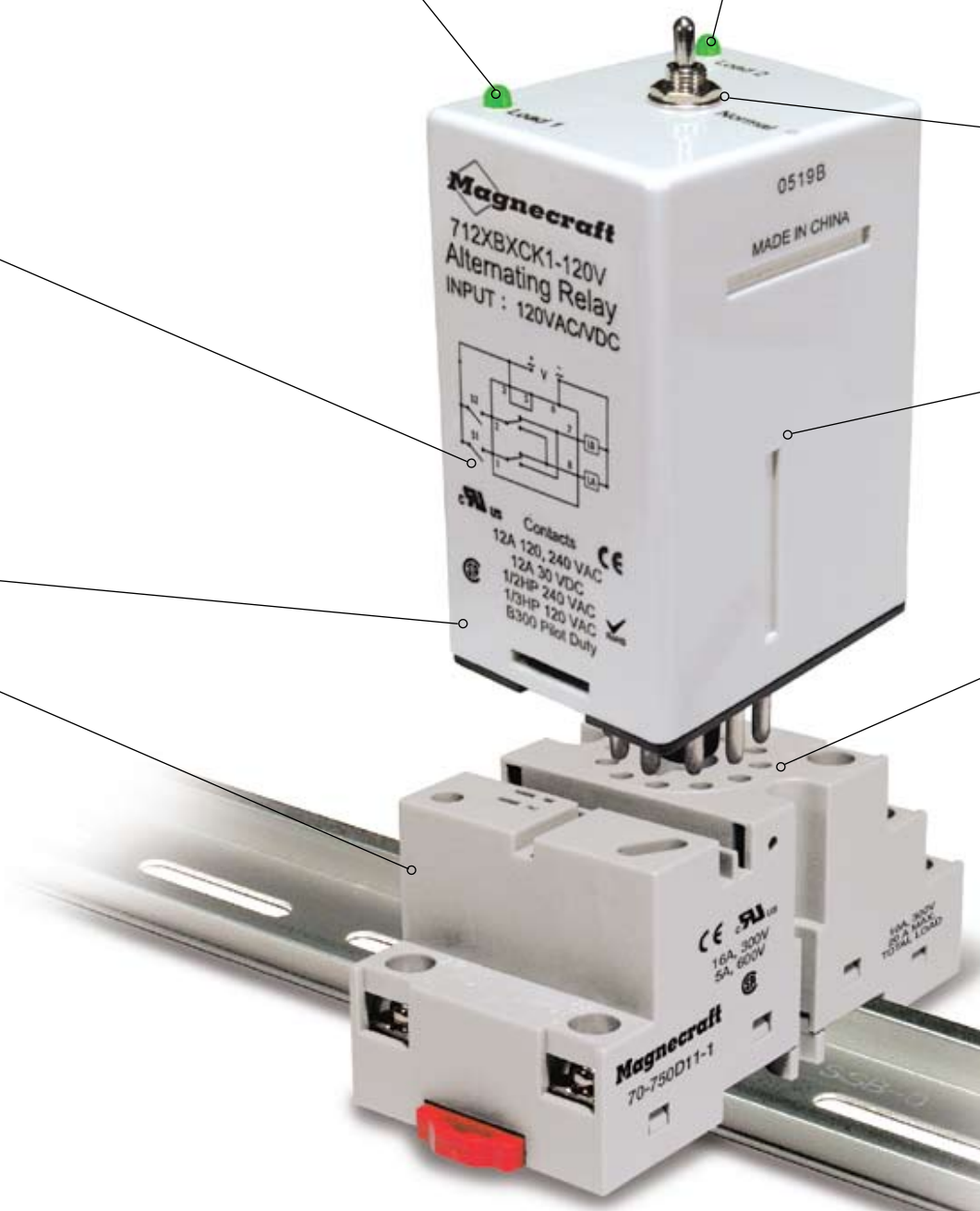

# 712 Alternating Relay/DPDT, 12 Amp Rating

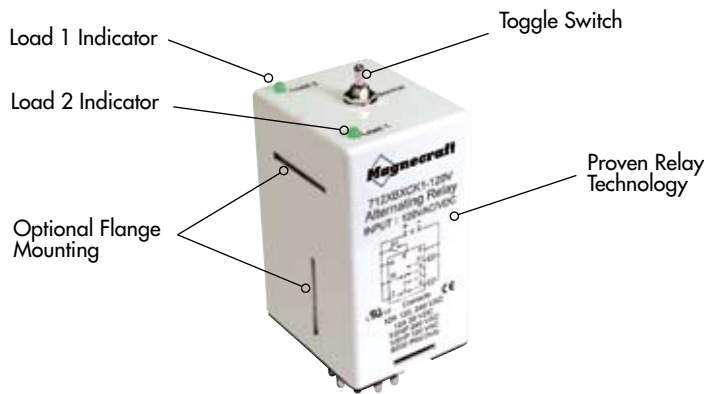

712 Relay with the 70-750DL8-1 Socket

## General Specifications (UL 508)

Contact Characteristics		Units	712XAXC	712XBXC	712XBXCK	712XBXCK1
Number and type of Contacts			SPDT	DPDT CROSS WIRED	DPDT, PIN 9 - NO PIN 11 - NC	DPDT, PIN 9 - NC PIN 11 - NO
Contact materials			Silver Alloy			
Thermal (Carrying) Current		A	12			
Maximum Switching Voltage		V	300			
Current rating		~ Resistive	12A @ 240V 50/60Hz			
Switching voltage		~ Resistive	12A @ 30V			
		~ HP	1/3 @ 120 VAC			
		~ HP	1/2 @ 240 VAC			
Minimum Switching Requirement		Pilot Duty mA	B300 100 @ 5 VDC (.5W)			
Coil Characteristics						
Voltage Range		~ V	12, 24, 120			
		~ V	240			
Operating Range		% of Nominal	80% to 110%			
		~ V	80% to 110%			
Average consumption		~ W	1.8			
		~ W	1.8			
Drop-out voltage threshold		~ V	15%			
		~ VDC	10%			
Timing Characteristics						
Time Delay - Fixed		s	0.5			
Reset Time		ms	100			
Alternating Action		Maximum	Release of Control Switch			
Performance Characteristics						
Electrical Life (UL 508)		(Resistive)	100,000			
Mechanical Life		Operations @ Rated Current	10,000,000			
Rated insulation voltage		Unpowered	~ V(rms)	1500		
		Between coil and contact	~ V(rms)	500		
Dielectric strength rms voltage		Between poles	~ V(rms)	1500		
		Between contacts	~ V(rms)	1500		
Environment						
Product certifications			UR, CSA, CE			
Ambient air temperature around the device		Standard version	°C	-30...+70		
		Storage	°C	-20...+60		
Degree of protection		Operation		IP 40		
Weight			grams	120		

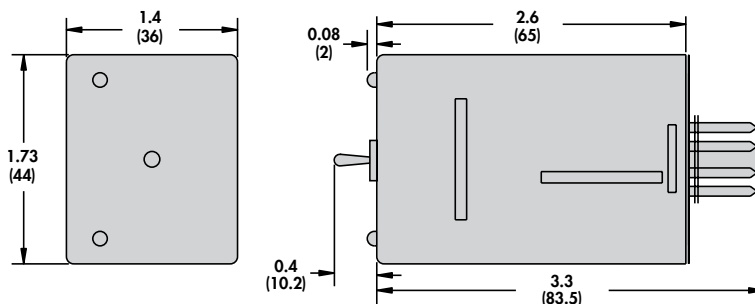

**Standard Part Numbers**

**BOLD-FACED PART NUMBERS ARE NORMALLY STOCKED**

Part Numbers	Input Voltage	Timing Range	Contact Configuration	Rated Load Current
8 Pin Octal Base, SPDT				
712XAXC-12V	12 VAC/VDC	0.5s Fixed	SPDT	12 Amps
712XAXC-24V	24 VAC/VDC	0.5s Fixed	SPDT	12 Amps
<b>712XAXC-120V</b>	120 VAC/VDC	0.5s Fixed	SPDT	12 Amps
712XAXC-240A	240 VAC	0.5s Fixed	SPDT	12 Amps
8 Pin Octal Base, DPDT (CROSS WIRED)				
712XBXC-12V	12 VAC/VDC	0.5s Fixed	DPDT	12 Amps
712XBXC-24V	24 VAC/VDC	0.5s Fixed	DPDT	12 Amps
<b>712XBXC-120V</b>	120 VAC/VDC	0.5s Fixed	DPDT	12 Amps
712XBXC-240A	240 VAC	0.5s Fixed	DPDT	12 Amps
11 Pin Octal Base, DPDT (PIN 11 NC)				
712XBXCK-12V	12 VAC/VDC	0.5s Fixed	DPDT	12 Amps
712XBXCK-24V	24 VAC/VDC	0.5s Fixed	DPDT	12 Amps
<b>712XBXCK-120V</b>	120 VAC/VDC	0.5s Fixed	DPDT	12 Amps
712XBXCK-240A	240 VAC	0.5s Fixed	DPDT	12 Amps
11 Pin Octal Base, DPDT (PIN 11 NO)				
712XBXCK1-12V	12 VAC/VDC	0.5s Fixed	DPDT	12 Amps
712XBXCK1-24V	24 VAC/VDC	0.5s Fixed	DPDT	12 Amps
<b>712XBXCK1-120V</b>	120 VAC/VDC	0.5s Fixed	DPDT	12 Amps
712XBXCK1-240A	240 VAC	0.5s Fixed	DPDT	12 Amps

**Part Number Builder**

Series	Contact Configuration	Pin Orientation	-	Input Voltage
712	XAX = SPDT	C = 8 OCTAL	-	12V = 12 VAC/VDC
	XBX = DPDT	CK = 11 PIN OCTAL (PIN 11 NC)		24V = 24 VAC/VDC
		CK1 = 11 PIN OCTAL (PIN 11 NO)		120V = 120 VAC/VDC
				240A = 240 VAC

Other mating sockets see Section 2: 70-750DL11-1, 70-750E8-1, 70-750E11-1, 70-464-1, 70-465-1, 70-169-1, 70-170-1

**Relay Adapters**



**16-711C4**  
Section 3, p.14-16



**16-711C1**  
Section 3, p.14-16

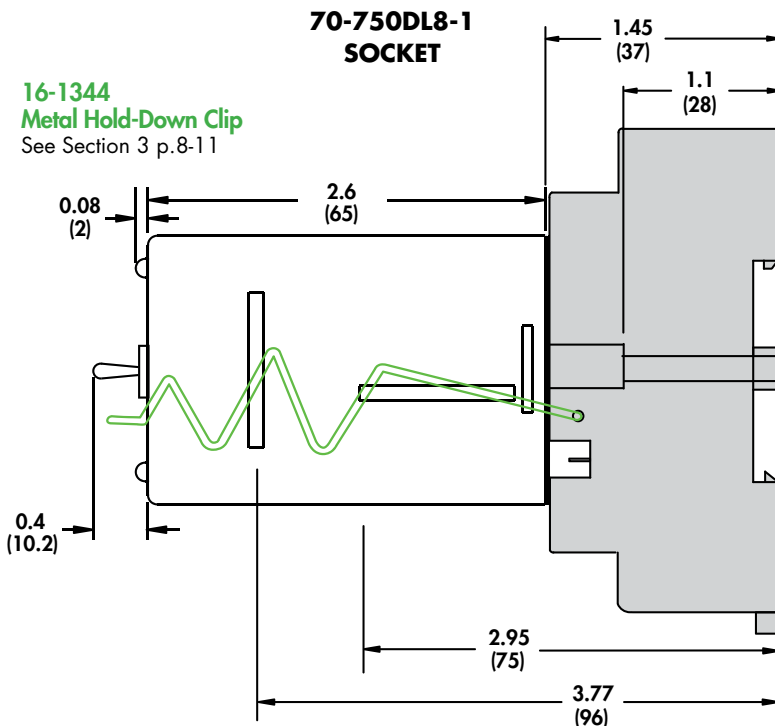

# Theory of Operation

Wiring Diagram:  
712XAXC

8 Pin Octal, with an SPDT  
Contact Configuration.

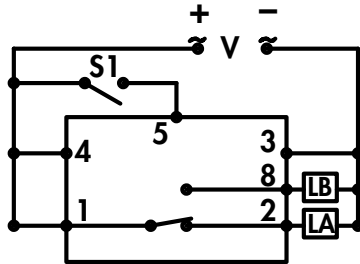

**A.**

V is Input Voltage  
LA is Load #1  
LB is Load #2  
S1 is Control Switch #1

If the Top Toggle Switch is in "Alternate" position closing Switch S1 will alternate the loads between LA and LB.

If the Top Toggle Switch is in "Lock 1" position Load LA is ON and Load LB is OFF. Switch S1 is not used in this mode.

If the Top Toggle Switch is in "Lock 2" position Load LA is OFF and Load LB is ON. Switch S1 is not used in this mode.

Wiring Diagram:  
712XBXC (DUPLEX)

8 Pin Octal, with a DPDT  
Contact Configuration.  
Duplex Capabilities.

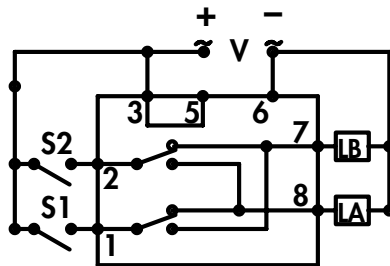

**B.**

V is Input Voltage  
LA is Load #1  
LB is Load #2  
S1 is Control Switch #1  
S2 is Control Switch #2

If the Top Toggle Switch is in "Alternate" position closing Switch S1 will alternate the loads between LA and LB while switch S2 will only control LA.

If the Top Toggle Switch is in "Lock 1" position Switch S1 will control LA while switch S2 will control LB.

If the Top Toggle Switch is in "Lock 2" position Switch S1 will control LB while switch S2 will control LA.

Duplex (Cross Wired) Functionality: This model operates the same as alternating relays except when both the control Switches S1 and S2 are closed, Load A and Load B energize simultaneously. The DPDT 8-pin, cross wired option, allows extra system load capacity through simultaneous operation of both motors when needed. Relay contacts are not isolated.

**Wiring Diagram:  
712XBXC**

11 Pin Octal with a DPDT Contact Configuration. Pin 9 is Normally Open and Pin 11 is Normally Closed.

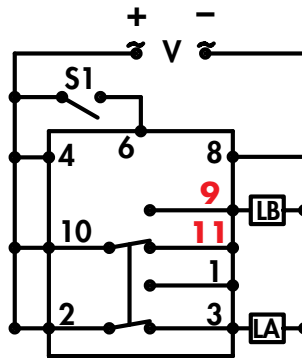

**C.**

V is Input Voltage  
LA is Load #1  
LB is Load #2  
S1 is Control Switch #1

If the Top Toggle Switch is in "Alternate" position closing Switch S1 will alternate the loads between LA and LB.

If the Top Toggle Switch is in "Lock 1" position Load LA is ON and Load LB is OFF. Switch S1 is not used in this mode.

If the Top Toggle Switch is in "Lock 2" position Load LA is OFF and Load LB is ON. Switch S1 is not used in this mode.

**Wiring Diagram:  
712XBCK1**

11 Pin Octal with a DPDT Contact Configuration. Pin 9 is Normally Closed and Pin 11 is Normally Open.

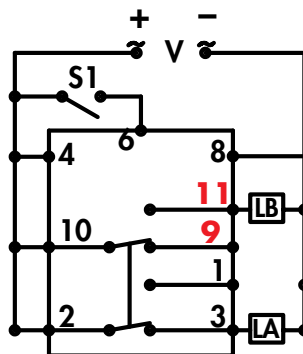

**D.**

V is Input Voltage  
LA is Load #1  
LB is Load #2  
S1 is Control Switch #1

If the Top Toggle Switch is in "Alternate" position closing Switch S1 will alternate the loads between LA and LB.

If the Top Toggle Switch is in "Lock 1" position Load LA is ON and Load LB is OFF. Switch S1 is not used in this mode.

If the Top Toggle Switch is in "Lock 2" position Load LA is OFF and Load LB is ON. Switch S1 is not used in this mode.

Note: Input voltage must be applied at all times for proper alternation. The use of a solid state control switch for S1 or S2 may not initiate alternation correctly. S1 or S2 voltage must be from the same supply as the unit's input voltage (see wiring diagrams). Loss of input voltage resets the unit; Load A becomes the lead load for the next operation.