

Definite Purpose Control

Class 8910, 8911, 8965, 9998, 9999



CONTENTS

Description	Page
Types DP, DPA and SYD	3-8
Dimensions	6-7
Fusible	8
Types DPS and H through M	9-12
Wiring Diagrams	12
Reversing Hoist	13-15
Replacement Parts	16-18



SQUARE D
GROUPE SCHNEIDER

Definite Purpose Contactors Types DP, DPA and SYD — Class 8910

- Compact Design
- Industry Standard Mounting
- Double Break Contacts
- Low Coil VA
- Straight-Through Wiring
- Low Cost

Definite purpose contactors are ideal for heating, air conditioning, refrigeration, data processing, and food service equipment. New compact 1 and 2 pole contactors are available along with full size 2, 3, and 4-pole devices.

They feature quick connect terminals and binder head screws for easy wiring. Box lugs are standard on 40 ampere contactors and larger. An exclusive DIN track mounting option may reduce installation costs. Coils can be changed on the Type DPA contactors quickly without a tool. Auxiliary contact modules snap on either side of the Type DPA contactors.

Compact 1-Pole Contactors – 600 Vac Maximum

Full Load Amperes	Locked Rotor Amperes			Resistive Load Amperes	Horsepower Ratings		N.O. Poles	Type
	277 V	460 V	575 V		115 V 1Ø	230 V 1Ø		
20	100	100	80	25	1	2	1	DP11*
25	125	125	100	30	2	3	1	DP21*
30	150	150	120	40	2	3	1	DP31*
40	240	200	160	50†	2	5	1	DP41*

† 50 A Res. limited to 277 V. All others rated 40 A Res. (above 277 V).

* Voltage code must be specified to order this product. Refer to standard voltage codes listed below.

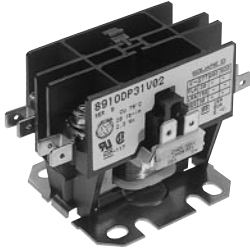

Type DP31V02
1-Pole

Compact 2-Pole Contactors – 600 Vac Maximum ■

Full Load Amperes	Locked Rotor Amperes			Resistive Load Amperes	Horsepower Ratings		N.O. Poles	Type
	277 V	460 V	575 V		115 V 1Ø	230 V 1Ø		
20	100	100	80	30	1	2	2	DP12*
25	125	125	100	35	2	3	2	DP22*
30	150	150	120	40	2	5	2	DP32*
40	240	200	160	50	2	5	2	DP42*

■ Above 240 volts, all lines must be switched.

2, 3, and 4-Pole Contactors – 600 Vac Maximum ■

Full Load Amperes	Locked Rotor Amperes			Resistance Load Amperes	Horsepower Ratings				N.O. Poles	Type
	230 V	460 V	575 V		115 V 1Ø	230 V 1Ø	230 V 3Ø	460/575 V 3Ø		
20	120	100	80	25	1	2	5	7½	2 3 4	DPA12* DPA13* DPA14*
25	150	125	100	35	2	3	7½	10	2 3 4	DPA22* DPA23* DPA24*
30	180	150	120	40	2	5	10	15	2 3 4	DPA32* DPA33* DPA34*
40	240	200	160	50	3	7½	10	20	2 3 4	DPA42* DPA43* DPA44*
50	300	250	200	62	3	10	15	30	2 3	DPA52* DPA53*
60	360	300	240	75	5	10	25	30	2 3	DPA62* DPA63*
75	450	375	300	94	5	15	25	40	2 3	DPA72* DPA73*
90	540	450	360	120	7½	20	30	50	2 3	DPA92* DPA93*
120	720	600	480	120	7½	20	30	50	2 3	DPA122* DPA123*
132	800	800	520	132	3	SYD138*
220	1500	1500	1200	220	3	SYD230*
352	2200	2200	1800	352	3	SYD368*

■ Above 240 volts, all lines must be switched.

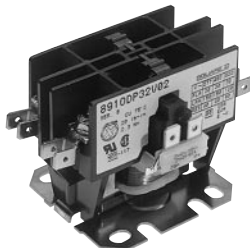

Type DP32V02
2-Pole



Type DPA33V02
3-Pole

Coil Voltage Codes

Voltage		Code Type DP, DPA	Code Type DPA122, DPA123, SYD
60 Hz	50 Hz		
24	24	V14	V12▲
24	V01▼
120	110	V02	V02
208	V08
208-240	220	V09	...
230-240	220	...	V03
277	...	V04	V04
480	440	V06	V06
600	550	V07♦	V07

▲ 24 V 50 Hz only.

▼ Available on Types DPA122, DPA123, and SYD138 only.

♦ Not available for Type DP one- and two-pole devices.



Definite Purpose Contactors

Class 8910 — Types DP, DPA and SYD Application Data

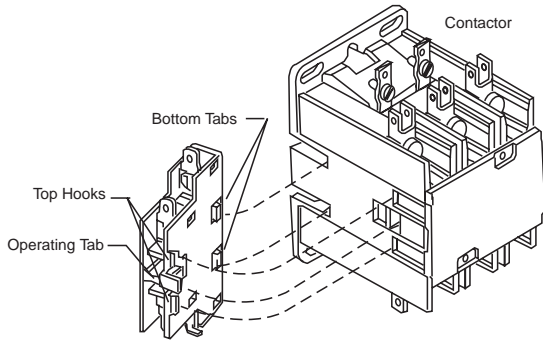

Auxiliary Contact Installation

2 Normally Open and 2 Normally Closed 4-Pole Contactors – 600 Vac Maximum

Full Load Amperes	Resistive Load Amperes	N.O. Poles	N.C. Poles★	Class 8910	
				Type	Form
20	25	2	2	DPA14*	Y392
25	35	2	2	DPA24*	Y392
30	40	2	2	DPA34*	Y392
40	50	2	2	DPA44*	Y392

* Voltage code must be specified to order this product. Refer to standard voltage codes listed in Coil Voltage Code Table.

■ Above 240 volts, all lines must be switched.

★ N.C. poles on outside. N.C. poles "open" before N.O. poles "close."

Auxiliary Contacts

For Use with Class 8910 Type	Contact Arrangement	Class 9999 Type
DPA	1 N.O. 1 N.C. 1 N.O. & 1 N.C. 2 N.O.	D10 D01 D11 D20
DPA122 DPA123 SYD	1 N.O. 1 N.C. 1 N.O. & 1 N.C.	SX6 SX7 SX8

NEMA Type 1 General Purpose Enclosures for Type DP and DPA Contactors

Class 8910 Type	Full Load Amperes	Poles	Class 9991 Type
DP	20-40	1 & 2	DPG1
DPA	20-40	2 & 3	DPG1
DPA	50 20-40	2 & 3 4	DPG2
DPA	60-75	2 & 3	DPG3
DPA	90-120	2 & 3	DPG4

Application Data

Mechanical Life: 500,000 operations

Electrical Life:
Type DP 100,000 operations
Type DPA, SYD 200,000 operations

Duty Cycle: Continuous

Approvals:
UL Listed File E42240, CCN NLDX
CSA Certified File LR25490, Class 3211 04



Definite Purpose Contactors

Types DP, DPA and SYD Application Data — Class 8910

Coil Replacement

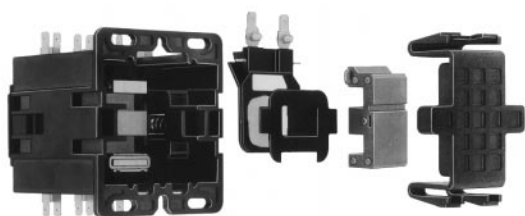

No tools required

Class 8910 Type DPA Replacement Coils

Full Load Amperes	Poles	Class 9998 Type	Volt Amperes†	
			Inrush	Sealed
20-40 A	2 & 3	DA1V*	56	6
20-40 A	4	DA2V*	109	10
50-60 A	2 & 3	DA2V*	109	10
75-90 A	2 & 3	DA3V*	214	19

* Replace asterisk with suffix from DPA Coil Table, shown below. Example: Coil for Class 8910 DPA33V02 120 volt 60 Hz would be a Class 9998 Type DA1V02.

† For Types DP11 thru DP32: Inrush 30 VA; Sealed 5 VA. Coils are not replaceable.

Type DPA Coil Table

Voltage, 60 Hz	Voltage, 50 Hz	Voltage Code
24	24	V14
120	110	V02
208-240	220	V09
277	...	V04
480	440	V06
600	550	V07▲

▲ Available for Type DPA contactors only.

Full Load Amperes	Power Terminals	
	Type of Lug	Wire Sizes† Minimum-Maximum
20-30 A	Binder Head	#14-#8
40 A	Box Lug	#14-#6
50-60 A	Box Lug	#14-#2
75-90 A	Box Lug	#14-#1/O
120 A	Box Lug	#14-#1/O
132 A	Box Lug	#8-350 MCM
220 A	Box Lug	#8-350 MCM
352 A	Box Lug	#4-500 MCM

† Solid or stranded copper wire only.

Miscellaneous Parts

Description	Class 9999 Type
DIN mounting bracket attachment	DMB1

Factory Modifications

Auxiliary contacts can be factory installed along with a DIN mounting bracket option. Special terminations are also available.

Modification	Form
Factory installed auxiliary contacts	●
Pressure wire connectors (20 - 30 Amp)	Y122
Box lugs (20 - 30 Amp)	Y124
DIN mounting bracket attached (35mm style)■	Y135

● Contact your local Square D office.

■ Available for 20 through 60 Amp only.



Definite Purpose Contactors

Class 8910 — Types DP, DPA and SYD Approximate Dimensions

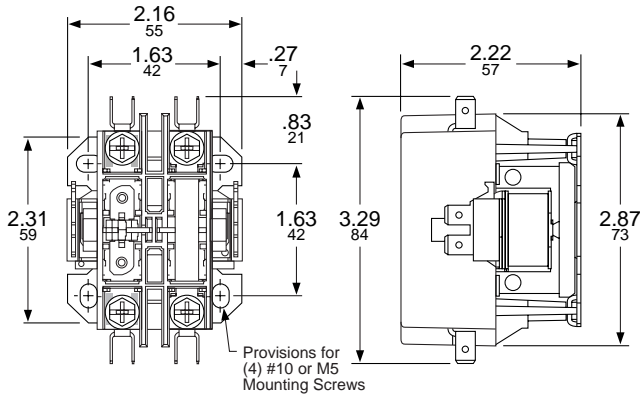

Type DP — 1-Pole
20 thru 30 Full Load Amps

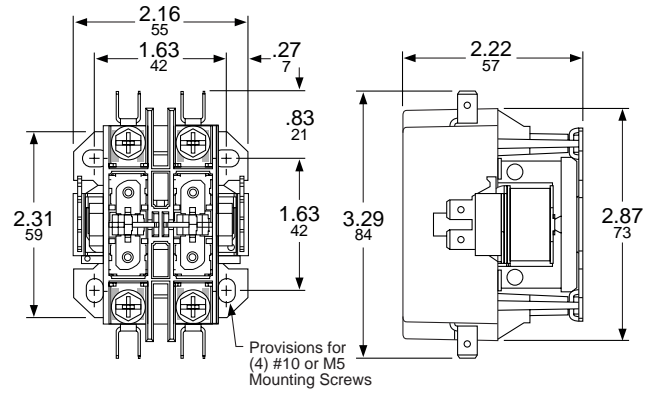

Type DP — 2-Pole
20 thru 40 Full Load Amps

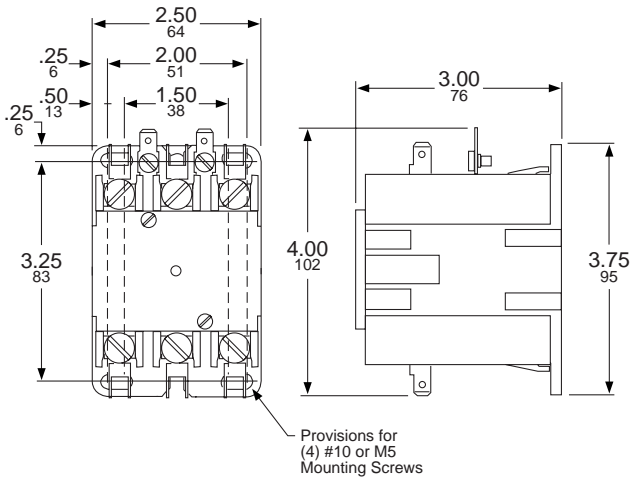

Type DPA — 2 and 3-Pole
20 thru 40 Full Load Amps

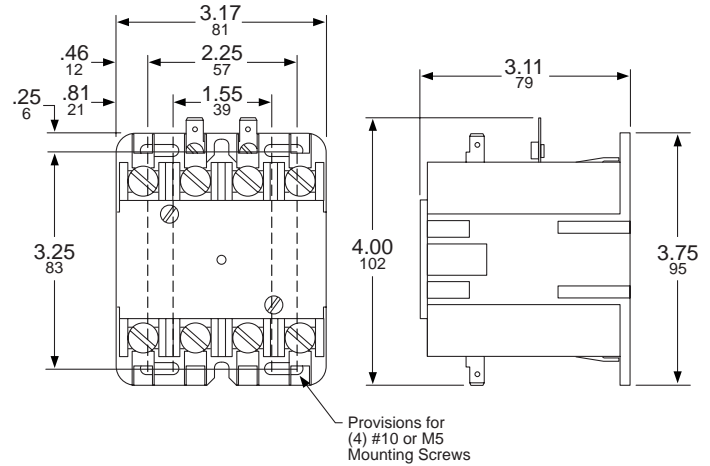

Type DPA — 4-Pole
20 thru 40 Full Load Amps

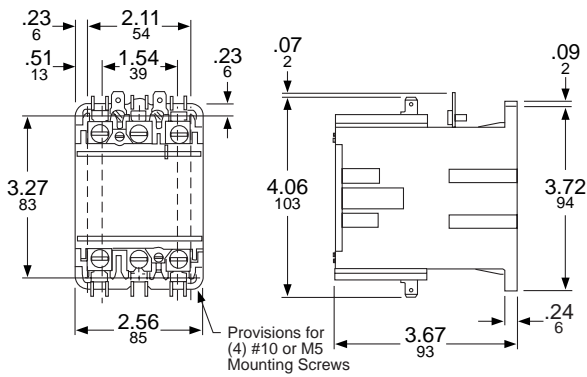

Type DPA — 2 and 3-Pole
50 and 60 Full Load Amps

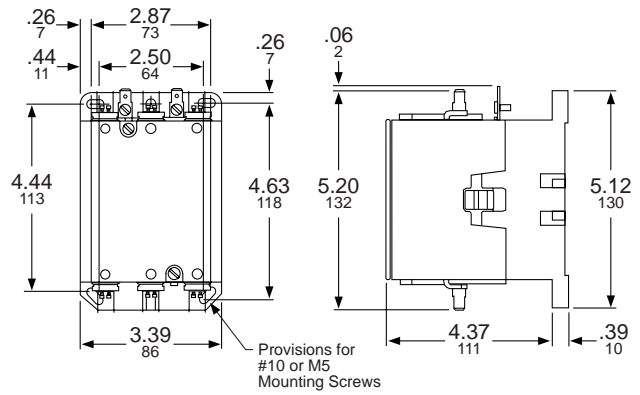

Type DPA — 2 and 3-Pole
75 and 90 Full Load Amps



Definite Purpose Contactors

Types DP, DPA and SYD Approximate Dimensions — Class 8910

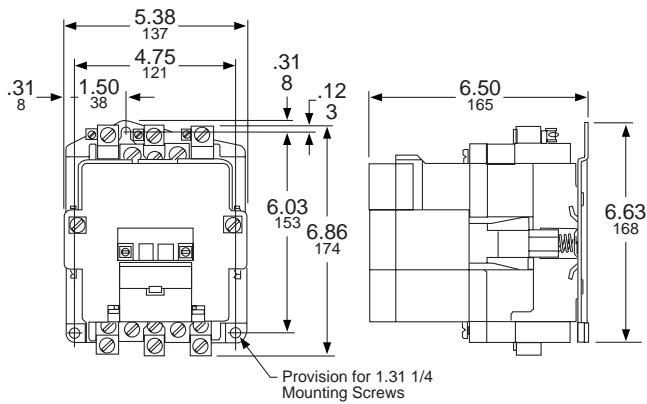

Type DPA
120 Full Load Amps

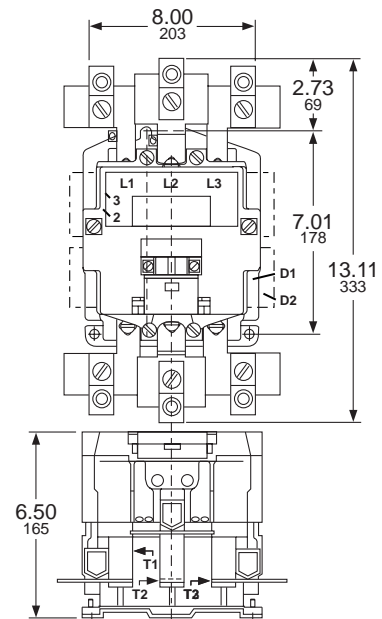

Type SYD230
220 Full Load Amps

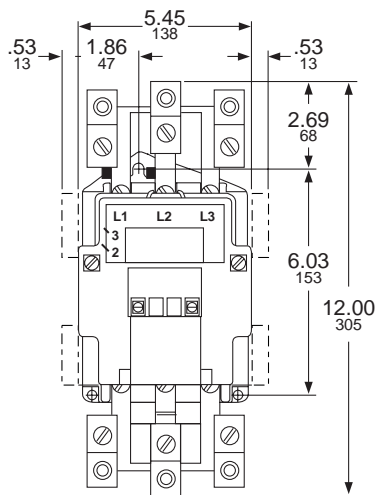

Type SYD138
132 Full Load Amps

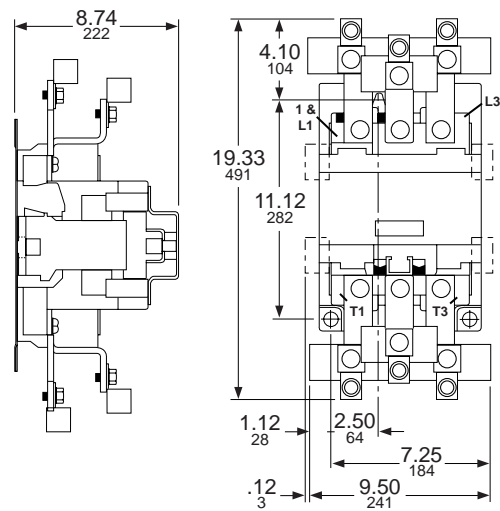

Type SYD368
352 Full Load Amps



Definite Purpose Contactors

Class 8910 — Type DPA Fusible

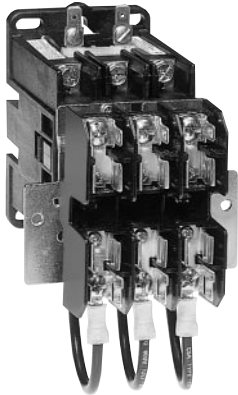

Type DPA23V02
Form DFM1

The Type DPA fusible contactor provides an integrally mounted fuse block with fuse clips electrically connected to the contactor. This factory assembled unit not only provides space savings but reduces installation cost as well, with only six field connections for a three pole unit and featuring one unit for two functions, i.e., short circuit protection for branch circuits and remote or manual power circuit interruption. The fusible contactor thus meets the provisions of the National Electric Code, Article 424 for overcurrent protection as well as limit controls for fixed electric space heating.

By a unique fuse clip arrangement, these devices can accommodate a variety of fuses for other electrical or electronic applications. This fused cover will accommodate the Type SC 300 volt fuse which is UL approved under Type G as well as the standard 1³/₃₂" by 1¹/₂" fuses.

Only UL Listed, Class G, K, H or J fuses meet branch circuit requirements when applied in accordance with NEC Article 240. Supplementary fuses shown may be used for additional equipment protection as defined in NEC 240-30. Consult manufacturer of selected fuse for proper application.

Selection Process

1. Determine the contactor ampere size required and coil voltage
2. Choose the appropriate fuse block and form from the table below.

Example: Class 8910 Type DPA33V02 Form DFG1

Fuse Block Selection Table

Type DPA13, 23, 33, 43 Form	Fuse Holder Description	Approximate Outer Dimensions					
		A		B		C	
		IN	mm	IN	mm	IN	mm
DFC1	Class CC, 3 A, 600 V, 1 ³ / ₃₂ x 1 ¹ / ₂	3.60	91	5.90	150	4.60	117
DFG1	Class G, 60 A, 480 V, 1 ³ / ₃₂ x 2 ¹ / ₄	3.60	91	6.10	155	4.70	119
DFG2	Class G, 25-30 A, 480 V, 1 ³ / ₃₂ x 1 ⁵ / ₈	3.60	91	5.90	150	4.50	114
DFH1	Class H or K, 30 A, 250 V, 9/ ₁₆ x 2	3.60	91	5.90	150	4.70	119
DFH2	Class H or K, 60 A, 250 V, 1 ³ / ₁₆ x 3	4.20	107	6.60	168	5.30	135
DFJ1	Class J, 30 A, 600 V, 1 ³ / ₁₆ x 2 ¹ / ₄	3.60	91	5.90	150	5.20	132
DFJ2	Class J, 60 A, 600 V, 1 ¹ / ₁₆ x 2 ³ / ₈	4.70	119	6.00	152	5.30	135
DFM1	Class M, 30 A, 600 V, 1 ³ / ₃₂ x 1 ¹ / ₂	3.60	91	5.90	150	4.60	117
DFR1	Class R, 30 A, 250 V, 9/ ₁₆ x 2	3.60	91	6.00	152	4.70	119
DFR2	Class R, 60 A, 250 V, 1 ³ / ₁₆ x 3	4.20	107	6.60	168	5.30	135
DFT1	Class T, 30 A, 300 V, 9/ ₁₆ x 7/ ₈	3.60	91	5.90	150	4.50	114
DFT2	Class T, 60 A, 300 V, 9/ ₁₆ x 7/ ₈	3.60	91	5.90	150	4.50	114
DFT3	Class T, 30 A, 600 V, 9/ ₁₆ x 7/ ₈	4.70	119	6.10	155	4.50	114
DFT4	Class T, 60 A, 600 V, 1 x 1 ¹ / ₁₆	4.70	119	5.90	150	4.50	114

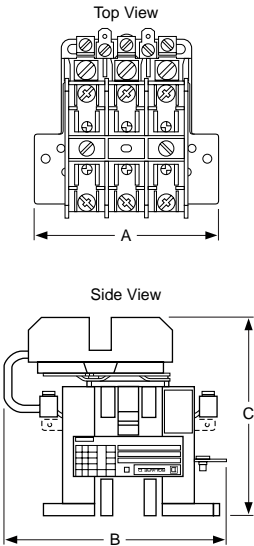

EBC Conversion to DPA Form DF

Rowan EBC Option	Fuse Amperes	Max. Volts	Fuse Dimensions	Fuse Class	Type DPA Form
-20	30	600	1 ³ / ₃₂ x 1 ¹ / ₂	M	DFM1
-21	30	480	1 ³ / ₃₂ x 1 ⁵ / ₈	G	DFG2
-22	60	480	1 ³ / ₃₂ x 2 ¹ / ₄	G	DFG1
-23	30	600	1 ³ / ₃₂ x 1 ¹ / ₂	M	DFM1
-24	30	480	1 ³ / ₃₂ x 1 ⁵ / ₈	G	DFG2
-25	60	480	1 ³ / ₃₂ x 2 ¹ / ₄	G	DFG1
-70	30	250	9/ ₁₆ x 2	H, K	DFH1
-71	60	250	1 ³ / ₁₆ x 3	H, K	DFH2
-72	30	600	1 ³ / ₁₆ x 2 ¹ / ₄	J	DFJ1
-73	60	600	1 ¹ / ₁₆ x 2 ³ / ₈	J	DFJ2
-74	30	250	9/ ₁₆ x 2	H, K	DFH1
-75	60	250	1 ³ / ₁₆ x 3	H, K	DFH2
-76	30	600	1 ³ / ₁₆ x 2 ¹ / ₄	J	DFJ1
-77	60	600	1 ¹ / ₁₆ x 2 ³ / ₈	J	DFJ2
-78	30	600	1 ³ / ₁₆ x 5	NA	NA
-79	60	600	1 ¹ / ₁₆ x 5 ¹ / ₂	NA	NA
-80	30	600	1 ³ / ₁₆ x 5	NA	NA
-81	60	600	1 ¹ / ₁₆ x 5 ¹ / ₂	NA	NA

Definite Purpose Starters Types DPS and H through M — Class 8911



Type DPSO23V02



Type DPSG23V02

Class 8911 definite purpose starters are inexpensive starters for applications with relatively low duty cycles. Typical applications include air compressors, agricultural equipment, pumps and HVAC equipment. Definite purpose starters offer:

- Low Cost
- Small Size
- Melting Alloy Overload Block
- Trip Free Reset Mechanism
- Open Type or Enclosed
- 500,000 Mechanical Operations

2, 3, and 4-Pole Starters – 600 Vac Maximum

Number of Poles	Full Load Amperes	Horsepower Ratings				Locked Rotor Amperes			Open Type	NEMA Type 1 Enclosed	Number of Thermal Units▲
		115 V 1Ø	230 V 1Ø	230 V 3Ø	460/575 V 3Ø	230 V	460 V	575 V	Type◆	Type◆	
Compact 2-Pole Single Phase	20	1	2	120	100	80	DSO12*	DSG12*	1
	25	2	3	150	125	100	DSO22*	DSG22*	
	30	2	5	180	150	120	DSO32*	DSG32*	
2-Pole Single Phase	20	1	2	120	100	80	DPSO12*	DPSG12*	1
	25	2	3	150	125	100	DPSO22*	DPSG22*	
	30	2	5	180	150	120	DPSO32*	DPSG32*	
	40	3	7½	240	200	160	DPSO42*	DPSG42*	
	50	3	10	300	250	200	DPSO52*	DPSG52*	
3-Pole Poly-Phase	20	1	2	5	7½	120	100	80	DPSO13*	DPSG13*	3
	25	2	3	7½	10	150	125	100	DPSO23*	DPSG23*	
	30	2	5	10	15	180	150	120	DPSO33*	DPSG33*	
	40	3	7½	10	20	240	200	160	DPSO43*	DPSG43*	
	50	3	10	15	30	300	250	200	DPSO53*	DPSG53*	
	60	5	10	20	40	360	300	240	DPSO63*	DPSG63*	
	75	5	15	25	50	450	375	300	DPSO73*	DPSG73*	
90	7½	15	30	60	540	450	360	DPSO93*	DPSG93*		

▲ See instruction sheet for selection information.

◆ Holding circuit contacts are not provided as standard; refer to table on Page 9.

* Voltage code must be specified to order this product. Refer to standard voltage codes listed below.

Approximate Dimensions

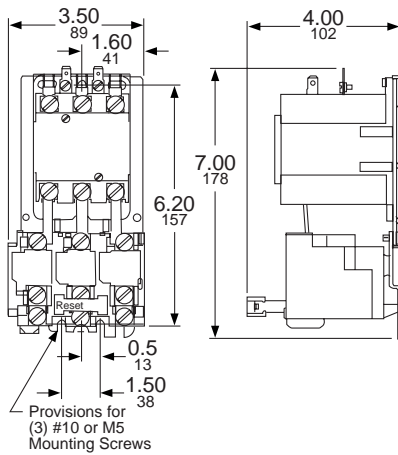

**Type DPSO – 2 and 3-Pole
20 - 50 Full Load Amps**

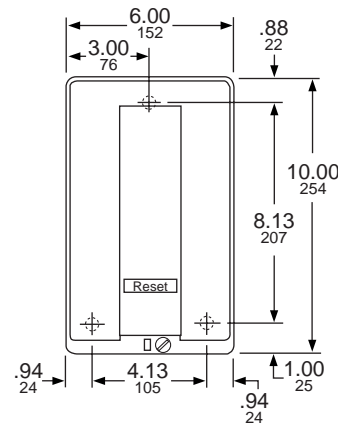

**Type DPSG – 2 and 3-Pole
20 - 40 Full Load Amps**



Definite Purpose Starters Class 8911 — Types DPS and H through M

Cross Reference Existing/Replacement Class 8911

Existing Device	Replacement Device
HO33	DPSO13
HG33	DPSG13
JO33	DPSO23
JG33	DPSG23
KO33	DPSO33
KG33	DPSG33
KO43	•
KG43	•
LO33	DPSO43
LG33	DPSG43
MO33	DPSO53
MG33	DPSG53
MO43	•
MG43	•

• Type DPS 4-Pole starter not available. Suggest 3-Pole device with auxiliary contact.

Miscellaneous Parts and Kits

Description	Class & Type
Start-Stop push button kit♦	8911 DPB1
Hand-Off-Auto selector switch kit♦	8911 DSS1
Standard N.C. overload relay contact	9998 SO1
N.C. and N.O. isolated overload relay alarm contacts	9999 SO4
Overload relay jumper strap	9998 SO31

♦ Use for 20 to 40 amp starters; for larger sizes, contact your local Square D office.

Class 8911 Replacement Coils

Full Load Amperes	Poles	Class 9998 Type	Volt Amperes	
			Inrush	Sealed
20-40 A	2 & 3	DA1*	56	6
50-60 A	2 & 3	DA2*	109	10
75-90 A	2 & 3	DA3*	214	19

* Replace asterisk with Voltage Code from the Coil Table shown below.

Coil Table

Voltage, 60 Hz	Voltage, 50 Hz	Voltage Code
24	24	V14
120	110	V02
208-240	220	V09
277	...	V04
480	440	V06
600	550	V07

Auxiliary Contacts For Type DPS Starters■

Description	Class 9999
1 N.O.	D10
1 N.C.	D01
1 N.O./1 N.C.	D11
2 N.O.	D20

■ Auxiliary contacts are available factory installed. Consult local Square D Field Sales Office.

Ratings – Overload Contacts and Auxiliary Contacts

Device	Volts AC	Pilot Duty – AC Only (35% Power Factor)		Continuous Current Rating
		Make	Carry & Break	
9998 SO1 9999 SO4	120 or Less	30 Amps	3 Amps	5 Amps
9999 R20 & R21 9999 D10, D01, D11 & D20	120-600	3600 VA	360 VA	5 Amps



Definite Purpose Starters

Types DPS with Adjustable Bimetallic Overload Relays — Class 8911

Class 8911 definite purpose starters are inexpensive starters for applications with relatively low duty cycles. Typical applications include air compressors, agricultural equipment, pumps, and HVAC equipment. Definite purpose starters offer:

- Ambient Temperature Compensated
- Adjustable Current Setting
- Class 10 or Class 20 Trip Rating
- Hand or Automatic Reset
- Single Phase Sensitivity
- No Separate Heaters Required
- 500,000 Mechanical Operations
- Open Type Only

2 and 3-Pole Starters – 600 Vac Maximum

Number of Poles	Full Load Amperes	Horsepower Ratings				Locked Rotor Amperes			Open Type
		115 V 1Ø	230 V 1Ø	230 V 3Ø	460/575 V 3Ø	230 V	460 V	575 V	
2-Pole Single Phase	20	1	2	–	–	120	100	80	DPSO12▲
	25	2	3	–	–	150	125	100	DPSO22▲
	30	2	5	–	–	180	150	120	DPSO32▲
	40	3	5	–	–	240	200	160	DPSO42▲
	50	3	7½	–	–	300	250	200	DPSO52▲
	60	5	10	–	–	360	300	240	DPSO62▲
3-Pole Polyphase	20	1	2	5	½	120	100	80	DPSO13▲
	25	2	3	7½	10	150	125	100	DPSO23▲
	30	2	5	10	15	180	150	120	DPSO33▲
	40	3	5	10	20	240	200	160	DPSO43▲
	50	3	7½	15	30	300	250	200	DPSO53▲
	60	5	10	20	30	360	300	240	DPSO63▲

▲ Voltage code and overload relay form must be specified to order this product
 Refer to standard voltage codes and overload relay forms listed below and insert as shown in HOW TO ORDER block.

Overload Relays Forms for Definite Purpose Starters

Motor Full Load Current Range (A)	For Use with Starter Type DPSO	For Class 10 Overload		For Class 20 Overload		Minimum Enclosure Size■	
		Form	Overload Relay	Form	Overload Relay		
0.1-0.16	20 A-40 A	DB.16F	LR2D1301	–	NA	A	
0.16-0.25		DB.25F	LR2D1302	–	NA	A	
0.25-0.40		DB.40F	LR2D1303	–	NA	A	
0.40-0.63		DB.63F	LR2D1304	–	NA	A	
0.63-1		DB1F	LR2D1305	–	NA	A	
1-1.6		DB1.6F	LR2D1306	–	NA	A	
1.6-2.5		DB2.5F	LR2D1307	–	NA	A	
2.5-4		DB4F	LR2D1308	DB4	LR2D1508	A	
4-6		DB6F	LR2D1310	DB6	LR2D1510	A	
5.5-8		DB8F	LR2D1312	DB8	LR2D1512	A	
7-10		DB10F	LR2D1314	DB10	LR2D1514	A	
9-13		DB13F	LR2D1316	DB13	LR2D1516	A	
12-18		DB18F	LR2D1321	DB18	LR2D1521	A	
17-25		25 A-40 A	DB25F	LR2D1322	DB25	LR2D1522	A
23-30		40 A	DB30F	LR2D2353	DB30	LR2D2553	A
28-36			DB36F	LR2D2355	–	NA	A
30-37	DB37F		LR2D3355	DB37	LR2D3555	B	
37-48	50 A		DB48F	LR2D3357	DB48	LR2D3557	B
48-60	60 A	DB60F	LR2D3359	DB60	LR2D3559	B	

■ Minimum recommended enclosure dimensions: A=10"H x 6.75"W x 6.25"D, B=14"H x 10.5"W x 7.25"D.



**Type DPS033V02
Form DB18**

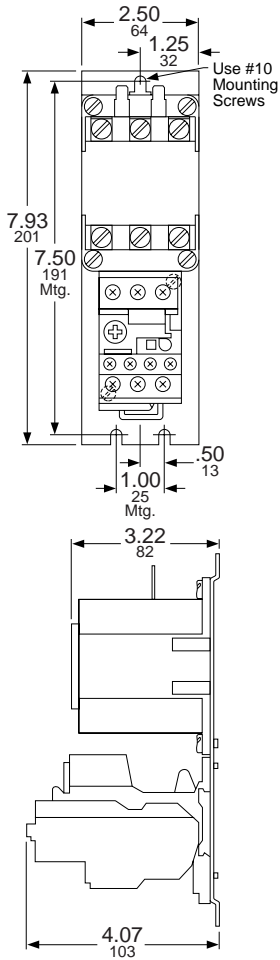

Definite Purpose Starters

Class 8911 — Types DPS with Adjustable Bimetallic Overload Relays

Auxiliary Contacts for Type DPS Starters

Description	Factory Installed FORM	Class 9999 Type
1 N.O.	X10	D10
1 N.C.	X01	D01
1 N.O./1 N.C.	X11	D11
2 N.O.	X20	D20

How to Order:

To Order Specify:		Catalog Number			
● Class Number	● Type Number	Class	Type	Coil Voltage Code	Form(s)
● Voltage Code or Voltage	● Forms	8911	DPS012	V02	DB1.6FX10

Coil Voltage Codes

Volts		Voltage Code
60 Hz	50 Hz	
24	24	V14
120	110	V02
208-240	220	V09
277	-	V04
480	440	V06
600	550	V07

Single-Phase 2-Wire System

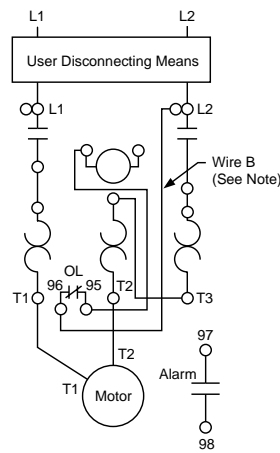

Three-Phase 3-Wire System

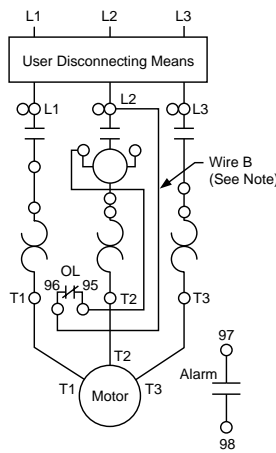

NOTE: Wire "B" is omitted on starters with coils of 120 V or less.

Three-Phase Starter Wired to Control a Single-Phase Motor

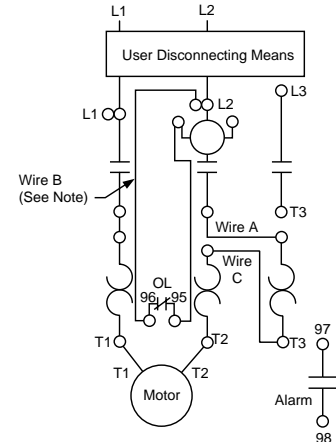

Remove power jumpers connecting contactor T2 and T3 to overload L2 and L3. Install power wires "A" and "C" (provided by user).



Definite Purpose Contactors

Reversing Hoist, Type DPR — Class 8965



Type DPR23V02

Class 8965 Type DPR reversing/hoist contactors are designed for the control of motors in hoists, overhead doors, small elevators, commercial laundry equipment, and other related products which use reversing motors. They are rated to perform in the short periods of jogging experienced in hoist service.

The coils are designed to operate on line voltages of 85% to 110% of rated voltage, and are for applications at 50 or 60 Hz only. Coils are easily replaced with external base removed.

Auxiliary contacts may be easily field-added to any Class 8965 reversing contactor. Type DPR contactors accept one auxiliary contact module with up to two isolated circuits per side (two modules per device). When auxiliary contacts are ordered separately, two modules are normally used for each device; one for forward, one for reverse.

Approvals: UL Listed – File E42240, CCN NLDX
CSA Certified – File LR25490, Class 3211 04

Reversing/Hoist Contactors – 600 Volts AC Maximum

No. of Poles	Horsepower Ratings▲				Open Type Type	Replacement Coil♦
	115 V 1Ø	230 V 1Ø	230 V 3Ø	460/575 V 3Ø		
3-Pole Poly-Phase	1	2	3	5	DPR13*	DA1*
	2	3	7½	10	DPR23*	DA1*
	2	5	10	15	DPR33*	DA1*
	3	7½	15	20	DPR43*	DA1*
	3	10	15	30	DPR53*	DA2*
4-Pole Poly-Phase	2	3	7½	10	DPR34*	DA2*
	3	7½	10	20	DPR44*	DA2*

Coil Voltage Codes

Volts, 60 Hz	Volts, 50 Hz	Voltage Code
24	24	V14
120	110	V02
208-240	220	V09
277	–	V04
480	440	V06
600	550	V07

- ▲ For rapid operation (jogging duty), use the next larger size contactor.
- ♦ Order two replacement coils for reversing contactors.
- * Voltage code must be specified to order this product. Refer to standard voltage codes listed to the left.

Auxiliary Contacts Separate Module†

Description	Class 9999 Type
1 N.O.	D10
1 N.C.	D01
1 N.O.-1 N.C.	D11
2 N.O.	D20

† Order two modules for Type DPR, one for each side.

Factory Installed

Description	Form
1 N.O. Each Side	X1010
1 N.C. Each Side	X0101
1 N.O.-1 N.C. Each Side	X1111
2 N.O. Each Side	X2020

Approximate Dimensions

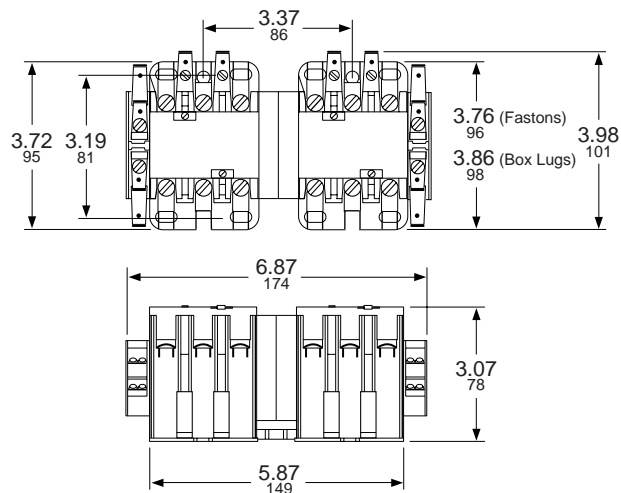

Definite Purpose Contactors

Class 8965 — Reversing Hoist, Type R



Type RO10V02

Class 8965 Reversing Hoist Contactors meet the small space requirements found in electrical hoists, light duty cranes, door operators, and related products. They are designed to perform in the short periods of jogging experienced in hoist service. Note that these contactors must be mounted upright on the vertical plane; the contactors will not operate properly when mounted in any other position.

Application Data

Coils Duty: Hoist Duty-H4 Intermittent
 Voltage Range: AC coils only +10%, -15% of nominal

Burden Inrush 76 VA, Sealed 27 VA

Approvals

UL Component Recognized File E78351, CCN NLDX2
 CSA CertifiedFile LR60905, Class 3211 04

AC Reversing/Hoist Contactors – 600 Volts AC Maximum

Number of Poles	Horsepower Ratings				Power Terminals	With▲ Jumper Straps	Without▲ Jumper Straps
	115 V 1Ø	230 V 1Ø	230 V 3Ø	460/575 V 3Ø		Open Type	Open Type
3-Pole Polyphase	1	1-1/2	3	3	Quick Connect	RO10*	RO11*
					Pressure Wire■	RO12*	RO13*

▲ Jumper straps connect the line side power terminals of the same phase between the forward (up) and reverse (down) contactors in common; ie L1 to L1, L2 to L2 and L3 to L3.

■ Coils rated 120 Vac or less are supplied with quick connect terminals only.

* Voltage code must be specified to order this product. Refer to standard voltage codes shown in the Coil Table below.

Miscellaneous Hoist Contactor Kits

For Use with Class 8965		Description	Class	Type
Type	Forms			
RO10 RO11 RO12 RO13	All	Armature Kit	9998	RP1
		Contact Carrier	Order as Part Number 31002-060-50	

★ CP10 Discount Schedule.

Auxiliary Contacts Separate Module

Description	Terminals	Class 9999 Type
1 N.O. Each Side	Quick Connect	R10
	Screw	R12
1 N.C. Each Side	Quick Connect	R11
	Screw	R13

Coil Table

Voltage 60 Hz	Voltage 50 Hz	Voltage Code	Replacement Part Number
24	—	V01	31002-403-19●
120	110	V02	31002-403-40●
208/220	—	V21	31002-400-47†
240	220	V03	31002-400-49†
480	—	V28	31002-400-58†
600	550	V07	31002-400-60†

● Tape wound coils, 2 per package.

† Molded coil, 1 per package.



Definite Purpose Contactors Reversing Hoist, Type R — Class 8965

Approximate Dimensions (3-Poles per Contactor)

Type	A		B		C		D		E		F		G	
	IN	mm	IN	mm	IN	mm	IN	mm	IN	mm	IN	mm	IN	mm
RO10, 11	3.31	84	3.31	84	3.03	77	2.69	68	1.34	34	1.56	40	2.66	68
RO12, 13	3.31	84	3.69	94	2.69	68	2.69	68	1.34	34	1.56	40	2.66	68

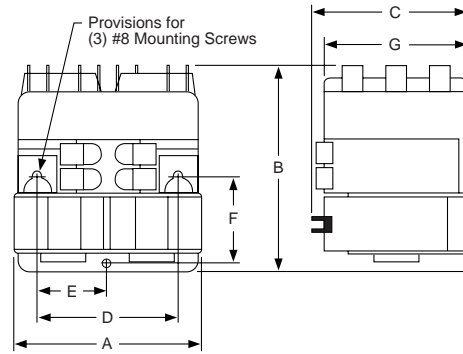

Cross Reference – Obsolete Devices

Obsolete Device		Replacement Device		Auxiliary Contact Required		Obsolete Device		Replacement Device		Auxiliary Contact Required		
Class	Type	Class	Type	Class	Type	Class	Type	Class	Type	Class	Type	
8702 or 8965	HO3	8965	RO12	—	—	8965	RO2	8965	RO10	9999	R10	
	HO4		RO12	9999	R12		RO11		9999	R10		
	HO5		RO12	9999	R13		RO2S1		RO10	9999	R10	
	HO6		RO12	—	—		RO2S2		RO10	9999	R10	
	HO7		RO12	9999	R12		RO3		RO10	9999	R11	
	HO8		RO12	9999	R13		RO3S1		RO11	9999	R11	
									RO3S2	RO10	9999	R11
									RO3S3	RO10	9999	R11
8965	RG2S1	8965	RO10	9999	R10	8965	RO4	8965	RO12	—	—	
	RG5S1		RO12	9999	R12		RO13		—	—		
	RG5S2		RO12	9999	R12		RO4S1		RO13	—	—	
	RO1		RO10	—	—		RO5		RO12	9999	R12	
	RO1S1		RO11	—	—		RO5S1		RO13	9999	R12	
	RO1S2		RO10	—	—		RO5S2		RO12	9999	R12	
	RO1S3		RO11	—	—		RO6		RO12	9999	R13	
	RO1S4		RO10	—	—		RO6S1		RO13	9999	R13	
	RO1S5		RO10	—	—		RO6S2		RO12	9999	R13	
	RO1S6		RO10	—	—							



Replacement Parts Kits

Class 9998 — Contact Kits



Class 9998 replacement parts kits are available for servicing Square D contactors. Each kit contains the necessary movable and stationary contacts, contact springs and additional hardware required to service the devices listed below. When servicing devices having more poles than contained in the corresponding kit, it may be necessary to order an additional kit.

Class 8965 Replacement Contact Kits

Equipment to Be Serviced		Class 9998 Parts Kit Type Number
Type	Series	
DPR13	B	DRC1
DPR23	B	DRC2
DPR33	B	DRC3
DPR43	B	DRC4
DPR53	B	DRC5
DPR63	B	DRC6
RO1-RO6	All	RA88
RO10	All	RA10
RO11	All	RA11
RO12	All	RA12

Class 8910 Replacement Contact Kits

Device to Be Serviced		1-Pole Type Number	3-Pole Type Number
Type	Series		
SYD138		—	SL27
SYD230		—	SL28
SYD368		—	SL29
DPA1	B	DRC1	—
DPA2	B	DRC2	—
DPA3	B	DRC3	—
DPA4	B	DRC4	—
DPA5	A, B	DRC5	—
DPA6	A, B	DRC6	—
DPA7	A	DRC7	—
DPA9	A	DRC9	—
DPA123	A	DRC12	—





Class 9998 Type SO1

Contact Units for Melting Alloy Type Overload Relays

One normally closed contact, Class 9998 Type SO1, is provided in each overload relay block on Class 8911 Type DPS starters. Contact modules can be easily replaced and are identified in the table below. Isolated overload relay alarm circuit contacts are available as an optional feature. A pilot light or alarm bell can be wired in series with this contact to indicate that the overload relay has tripped.

Magnetic Starter		Description▲	Parts Kit Number
Ampere Size	Type		
20 A through 90 A	DPS	Standard N.C. contact unit	Class 9998 Type SO1
		N.O. isolated alarm contact and standard N.C. overload contact	Class 9998 Type SO4

▲ Refer to Page 11-131 for contact ratings.

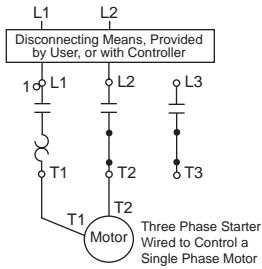

**Melting Alloy
Overload Relay
Jumper Strap Kits**

Melting Alloy Overload Relay Jumper Strap Kits

Jumper strap kits are for use on three-phase magnetic starters with melting alloy overload relays only, where a three-phase starter is used to control a single-phase motor. These kits will include two jumper straps, a wiring diagram showing how to wire a three-phase starter to control a single-phase motor, and single-phase (one thermal unit) selection tables.

Class	For Starter		Class 9998 Kit Type Number
	Ampere Size	Type	
ALL	20 A through 50 A	DPS	SO31
	60 A through 90 A	DPS	SO32



Replacement Parts Kits

Class 9999 — Auxiliary Contacts

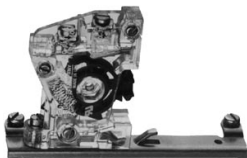

External
Single Circuit
Auxiliary Contact

External Contacts

Class 9999 Type SX6 through Type SX10 external auxiliary contacts can be added to Type DPA123 and SYD devices. These contacts mount on either side of the basic contactor and are available with convertible or non-convertible contacts. The contacts of the convertible version can be changed from N.O. to N.C. or vice versa in the field.

See table below for electrical ratings.

Class 8910 and 8911 Definite Purpose Contactors and Starters – Auxiliary Contacts

Device to be Serviced Class 8910 or 8911 Type	Auxiliary Contact Kit	
	Contact Arrangement	Class 9999 Type
DPA* DPS	1 N.O.	D10
	1 N.C.	D01
	1 N.O./1 N.C.	D11
	2 N.O.	D20

* Type DPA122 and DPA123 use same auxiliary contacts shown below. (Example: Class 9999 Type SX6).

For Use With Class 8910 Type	Kit Description	Class 9999 Type
DPA 123 SYD	External Field Convertible	
	1-N.O. Contact.....	SX6
	1-N.C. Contact.....	SX7
	1-N.O. and 1-N.C. Isolated Contacts.....	SX8
	1-N.O. Overlapping Contact.....	SX9#
	1-N.C. Overlapping Contact.....	SX10#

Class 8965 Reversing/Hoist Contactors – Auxiliary Contacts

Device to be Serviced Class 8965 Type	Auxiliary Contact Kit		
	Contact Arrangement	Type of Connector	Class 9999 Type
DPR	1 N.O.	Screw/ Q. C.	D10
	1 N.C.		D01
	1 N.O./1 N.C.		D11
	2 N.O.		D20
RO2 & RG2 RO10 Form X1 RO11 Form X1	1 N.O. each side	Slip-on	R10
RO3 & RG3 RO10 Form X2 RO11 Form X2	1 N.C. each side		R11
RO5 & RG5 RO12 Form X1 RO13 Form X1	1 N.O. each side	Screw	R12
RO6 & RG6 RO12 Form X2 RO13 Form X2	1 N.C. each side		R13

Maximum Ratings For Auxiliary Contacts

Class 9999 Type	Contact Ratings			
	Volts AC	AC Only (35% Power Factor)		Continuous
		Make	Break	
SX6-SX10	120 or Less	60 Amps	6 Amps	10 Amps



Square D Company
8001 Highway 64 East
Knightdale, NC 27545-9023
(919) 266-3671

Square D and  are registered trademarks of Square D Company.

Catalog No. 8910CT9301R6/97 May 1998 © 1998 Square D All Rights Reserved.
Replaces 8910CT9301