

179-012 to 179-019
~~179-021 to 179-030~~
179-054

Electronic Component Housings and PC Board Bases for Custom Circuits

**INNOVATION
IN INTERFACE**

Electronic Component Housings and PC Board Bases for Custom Circuits

With the trend to distribution and application of new technologies, more and more compact rail mountable housings with integrated connection systems are required for component PC board bases.

The comprehensive Phoenix housing range comprises three harmonized product groups: The **MODUFACE** and **UEG/UEGM** component housings and the **UM/UMK** PC board bases for custom circuits. The housings which are conceived in accordance with the modular principle accept printed circuit boards from a few square centimeters up to complex cards. All housings have in common the high stability, the solid workmanship and the rail mountable design.

The machine mounted components and ordered electronic groups are safely integrated in the component housings without additional screw fitting and provide full shock protection. The housings offer a wide range of connections from solid screw connections up to 2.5 mm² and tab connections through to multi-position electronic plug connectors.

The use of standard component housings reduces development time and costs, even the smallest batches and individual equipment can be economically produced. For large series the housings can be finished in a choice of six other colors in addition to the standard green color.

Range Review

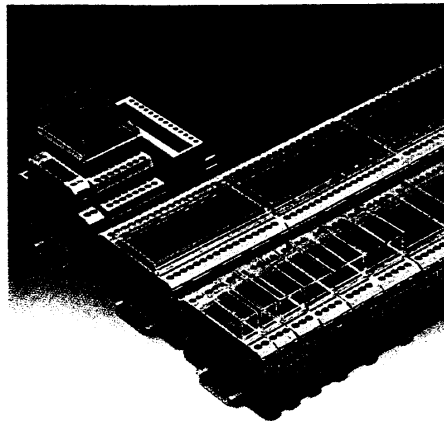

Component Housing MODUFACE

MODUFACE component housings are rail mountable small housings accepting electronic circuits and standard components.

MODUFACE offers a selection of approx. 20 housing variations, which are available with a number of positions and grids from 10 mm to 150 mm. The empty housings are offered with screw, tab or COMBICON connections to meet practical requirements.

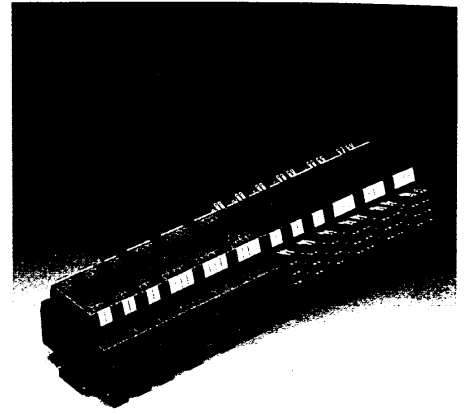

Component Housings UEG

The electronic component housing UEG is particularly suitable to accept made to measure adaption or conversion functions. It is available in 20 and 30 mm construction widths with individual custom fitted double level screw or tab connections. Using the universal foot these empty housings snap on to commercially available DIN EN mounting rails.

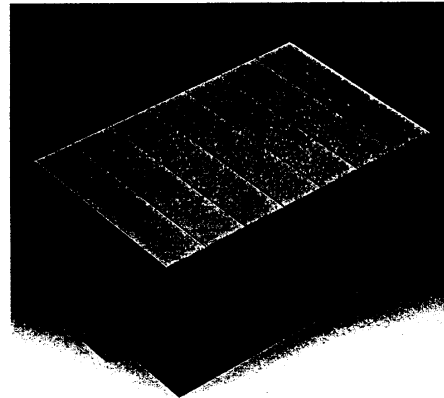
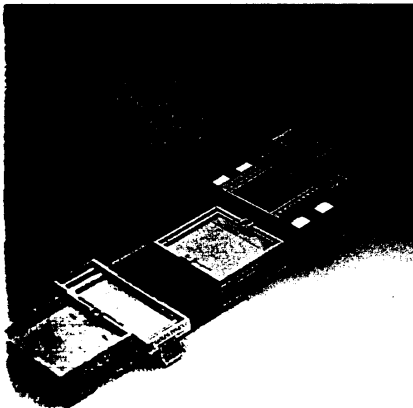

Component Housing UEG-EU

Using this housing for European format cards, even complex electronics are made rail mountable. The empty housing can be matched to all requirements by simply engaging the individual elements. Available as connection system are high position plug connectors as well as the comprehensive range of printed circuit terminal blocks (see catalog page 290).



PC Board Bases for Custom Circuits UMK

The universal module UMK permits professional rail mounting of electronics. The PC board bases for custom circuits are comprised of individual elements which can be optionally extended in the mounting rail longitudinal direction in accordance with the printed circuit board size. With its universal foot it can be engaged on commercially available DIN EN mounting rails.

The following review shows the various housing ranges.

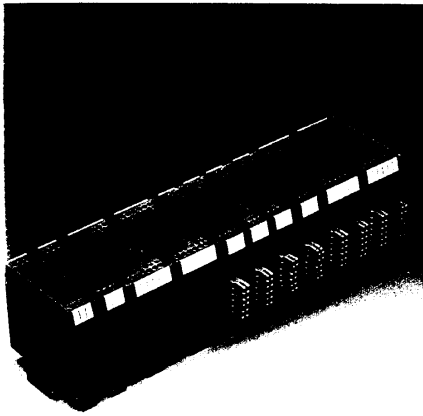

Component Housings UEGM

The electronic component housing UEGM offers the practical possibility of fitting individual interface functions. Due to the various construction widths (22.5, 25 and 40 mm) with optional screw and/or tab connections it easily meets individual requirements and needs. The housings snap on to commercially available DIN EN mounting rails.

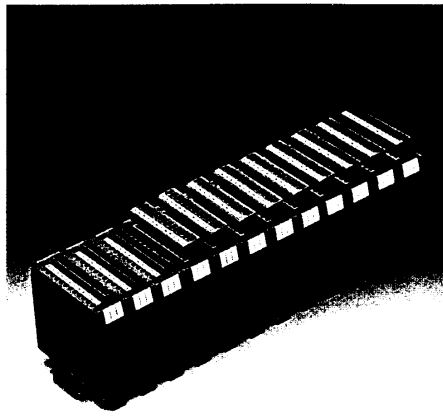

Component Housing UEGM-MSTB

The special feature of these 25 mm wide electronic component housings UEGM-MSTB is the connection of the external conductors through plug-in COMBICON pin strips. All standard COMBICON plug variations from 2 to 12 positions can mate the COMBICON pin strips. The individual connection points can be provided with light diodes. The empty housings possess a universal foot and snap on to commercially available DIN EN mounting rails.

Contents	Page
MODUFACE review	4-7
MODUFACE component housing	8-17
MODUFACE PCB layout	18-19
UEG component housing	20-21
UEGM component housing	22-23
UEGM-MSTB component housing	24
UEG-EU component housing	25
PCB layouts UEG, UEGM, UEGM-MSTB, UEG-EU	26-27
PC board bases for custom circuits UMK	28-29
Mounting plates UM	30-31
PC board bases for custom circuits MP	32

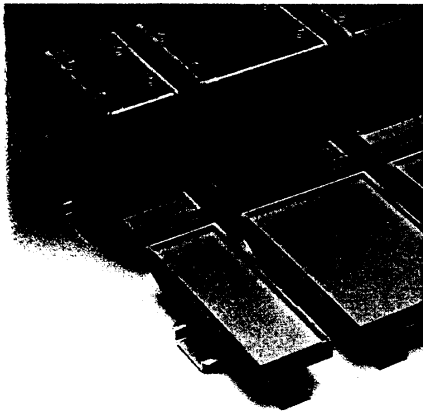

PC Board Bases for Custom Circuits UMK

The PC board bases for custom circuits UMK offer the possibility of economically and quickly expanding rail mounted electronic circuits. The printed circuit board size can be optionally expanded in the mounting rail longitudinal direction by simply fitting the UMK base elements in rows. The modules are available both with and without end covers. Due to their universal foot, these modules snap on to commercially available DIN EN mounting rails.

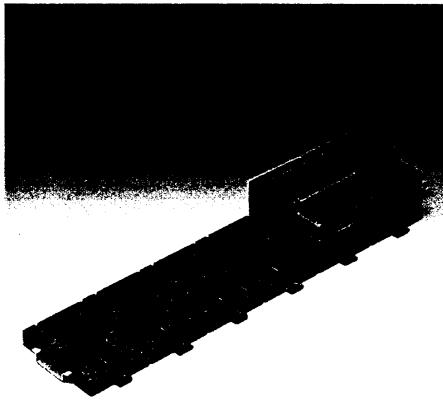

Mounting Plates MP

The mounting plates for rail fitting have been specially designed to accept size 0 switching equipment.

ODUFACE

General

MODUFACE is the name for a complete component housing range for the economical arrangement of industrial electronics according to switch cabinet referenced requirements. In the housing small interface circuits can be fitted as well as complete control units.

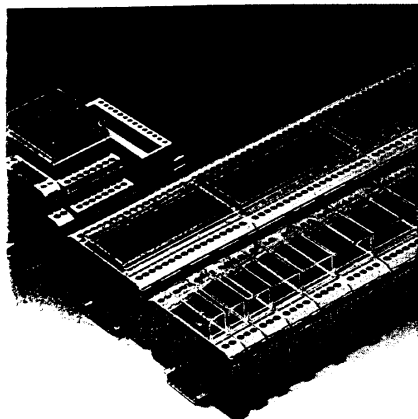

The component holder range can be divided into three delivery groups: The first delivery form: individual parts are supplied without printed circuit boards for complete custom fitting. The second delivery form: the prefabricated modules offer a standard printed circuit board with solder points for custom soldering of construction elements. The third delivery form: here various housing variations can be individually combined.

Common features for all MODUFACE products:

Uniform and well designed housing system

Optimum and space saving accommodation of the electronics in finely stepped module variants, which can be selected in grids from 10 to 150 mm

Practical and easily wired conductor connection through solid screw terminals up to 2.5 mm² very fine strand or optional 6.3/2.8x0.8 mm tab connections or COMBICON or electronic plug connectors.

Easy snap fitting on the symmetrical mounting rails in accordance with DIN EN 50022

Shock and soil protected accommodation of electronic components

Selection between three cover sizes in transparent or non-transparent design.

Design Principle

The blown-up view indicates the principle of the MODUFACE construction: the component fitted printed circuit board is inserted in the housing upper section and subsequently reliably engages with the housing base (no screws!).

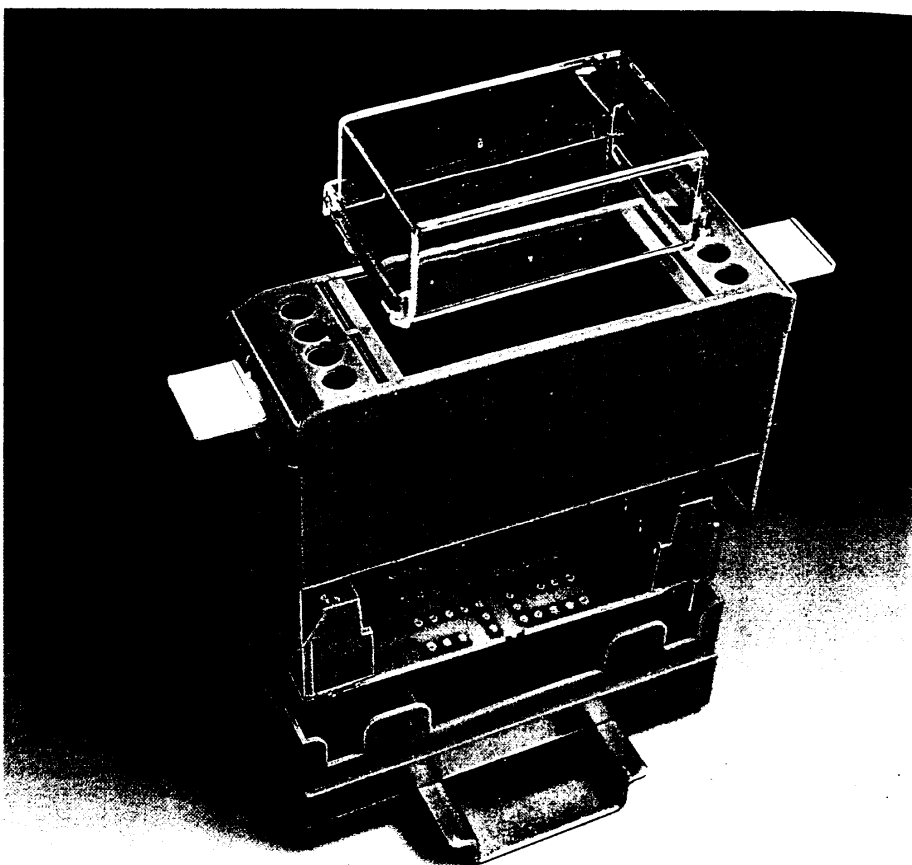

Electronic Component Accommodation

The fine type stages permit optimum adaption of the housings to the required printed circuit board surface for the electronic components and to the required connection positions and: the printed circuit board geometry is rectangular. The layout of each printed circuit board with its dimensions, the connection points and the component side is represented on pages 18-19 in a scale of 1:1. The special feature: all electronic components and printed circuit terminal blocks can be fitted in accordance with production requirements and machine soldered in one operating cycle!

To create construction modules as narrow as possible with comprehensive electronic components, one or several addi-

tional PCB's can be mounted perpendicularly on the main PCB, via suitable connection elements. The layout of this additional printed circuit board including dimensions, the points for the connection element and the component side is represented on page 19 in a 1:1 scale.

Three Cover Heights

The transparent or non-transparent green hoods available protect the internal electronics from shock and the ingress of dirt. The cover simply snaps on; it can be removed again at any time. The front permits the installation of display or actuation elements and a surface for a circuit print label. Economical quantities justify the production of covers upon request with front break-outs or prints.

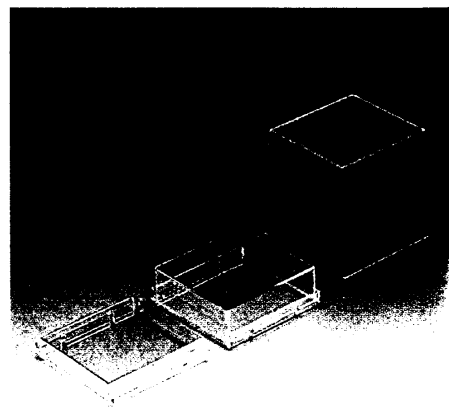
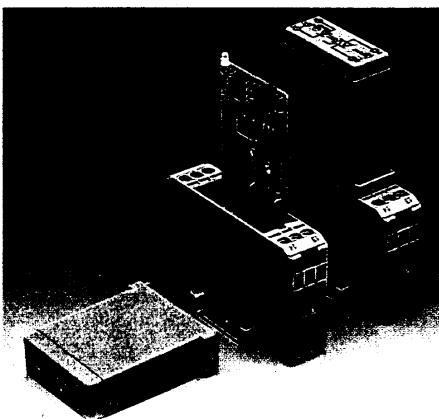

Special keying forms ensure that the covers can only be fitted in accordance with the circuit, i.e. as per the front print.

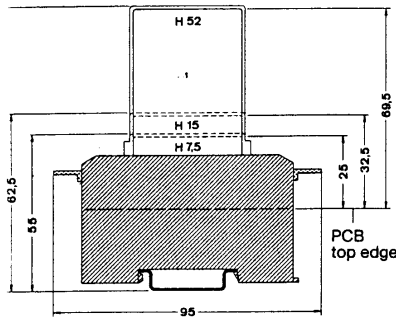

A selection can be made between three cover heights, permitting an optimum height matching to the electronics space requirement. The standard 7.5 and 15 mm high covers are transparent; upon request economical quantities allow the covers to be offered as non-transparent green. The 52 mm high cover is only available as non-transparent green. The tall covers are provided with guide grooves to accept the vertically positioned additional printed circuit boards.

Conductor Connections

Available designs are:
 solid 2.5 mm² screw connections in the form of printed circuit terminal blocks MKDS 3 in 5 mm grid dimensions on both sides (see catalog page 290). Some MODUFACE housings are alternatively available with screw terminal blocks with a 7.5 mm grid dimension; more details upon request.

Upon request, tab connections 6.3/2.8x0.8 mm; the 2, 3, and 4 position printed circuit strips with plastic ribs between the tabs can be fitted in rows in accordance with the grid spacing; to this effect the housing upper sections are supplied in a modified design on one or both sides with connection openings at the top.

Upon request with plug-in COMBICON connections when ordering economical batch sizes.

The connection components are always keyed with the electronic components on the printed circuit board and are machine ordered. The upper section of the MODUFACE housing ensures an aesthetically elegant integration of the connection elements.

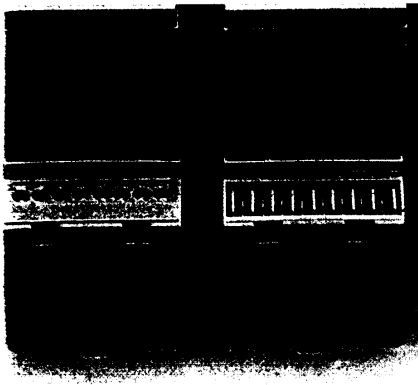

Marking

The marking of the connection terminal blocks is made on the marking slope by standard or individually printed marking strips SKS 5 or SKS 7.5 (see catalog page 290).

Economical quantities justify direct printing; more details upon request.

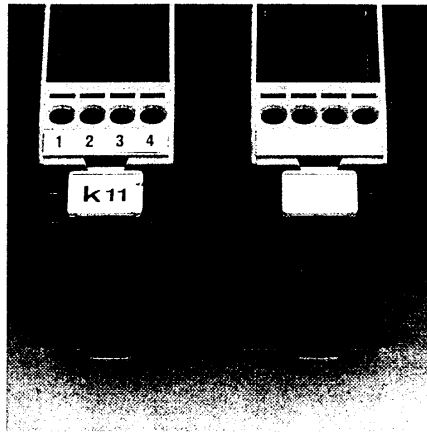

For module marking equipment marker labels EMG-GKS and EMG-SGKS are available, which can be inserted on both sides of the housing and individually marked.

Assembly

All MODUFACE modules are aligned in rows by simply engaging on the symmetrical mounting rail in accordance with DIN EN 50 022. Dismantling is made by pulling back the orange engagement latch.

To engage modules up to 30 mm width on the asymmetrical mounting rail in accordance with DIN EN 50 035 the adaptor EM-AD/NS 32 can be used.

Modules with a 12.5 and 25 mm width can also be individually mounted without a rail using a special plastic base.

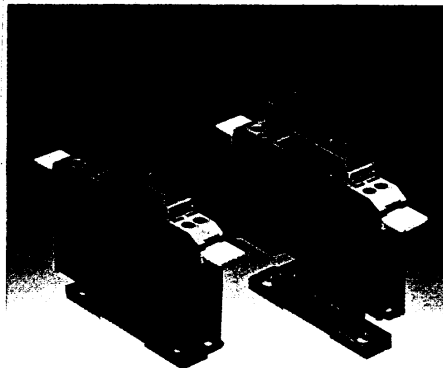

mm	to inch
25	= (0.984)
32.5	= (1.279)
55	= (2.165)
62.5	= (2.461)
69.5	= (2.736)
95	= (3.740)



















Materials

Housing components and transparent cover are made of difficult to ignite thermoplastics, suitable and internationally listed for permanent temperatures up to 100°C.







The housing protection type corresponds to IP 40; IP 20 for connection terminals.

ODUFACE Range Review

Available
Upon request

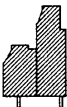
DUFACE ic sing	Type	Width/spacing [mm/inch]	No. of positions	MODUFACE covers															
				H 52 H 15 H 7.5 EMG 10-H... Page 8 10 (.394)	H 52 H 15 H 7.5 EMG 12-H... Page 8 12.5 (.492)	H 1 EMD 12-H... Page 15 12.5 (.492)	H 52 H 15 H 7.5 EMG 15-H... Page 9 15 (.590)	H 52 H 15 H 7.5 EMG 17-H... Page 9 17.5 (.689)	H 52 H 15 H 7.5 EMG 22-H... Page 9 22.5 (.886)	H 52 H 15 H 7.5 EMG 25-H... Page 10 25 (.984)	H 52 H 15 H 7.5 EMG 30-H... Page 10 30 (1.181)	H 52 H 15 H 7.5 EMG 37-H... Page 11 37.5 (1.476)							
	EMG 10 Page 8	10 (.394)	4	●															
	EMG 12 Page 8	12.5 (.492)	4		●														
	EMG 15 Page 9	15 (.590)	4 6				●												
	EMG 17 Page 9	17.5 (.689)	4 6					●											
	EMG 22 Page 9	22.5 (.886)	8							●									
	EMG 25 Page 10	25 (.984)	8		●						●								
	EMG 30 Page 10	30 (1.181)	10	●			●						●						
	EMG 37 Page 11	37.5 (1.476)	14		●														●
	EMG 45 Page 11	45 (1.772)	16				●			●									
	EMG 50 Page 11	50 (1.968)	18	●	●						●								
	EMG 75 Page 12	75 (2.953)	28		●						●								●
	EMG 90 Page 12	90 (3.543)	34	●			●			●			●						
	EMG 100 Page 13	100 (3.937)	38	●	●						●								
	EMG 125 Page 13	125 (4.921)	48		●						●								
	EMG 150 Page 13	150 (5.905)	56	●	●		●				●		●						●
	EMK 12 Page 14	12.5 (.492)	4																
	EMD 12 Page 15	12.5 (.492)	8					○											
	EME 45 Page 16	45 (1.772)	16	●	●						●								
	EMH 25 Page 17	25 (.984)	14																

MODUFACE connection elements

H 52 H 15 H 7.5	H 52 H 15 H 7.5	H 52 H 15 H 7.5	H 52 H 15 H 7.5	H 52 H 15 H 7.5	H 52 H 15 H 7.5	H 52 H 15 H 7.5						
AG 45-H... Page 11 45 (1.772)	EMG 50-H... Page 11 50 (1.968)	EMG 75-H... Page 12 75 (2.953)	EMG 90-H... Page 12 90 (3.543)	EMG 100-H... Page 13 100 (3.937)	EMG 125-H... Page 13 125 (4.921)	EMG 150-H... Page 13 150 (5.905)	MKDS... Catalog Page 290 5 (.197)	GMKDS... Catalog Page 292 7.5 (.295)	MKKDS... Catalog Page 291 5 (.197)	FLIS... Page 8 5 (.197)	MSTB... Catalog Page 302 5 (.197)	FRONT 1.5 F Info 28 Page 4 5 (.197)
							●					
							●			●	○	
							●	●				
							●	●		○	○	
							●			○	○	
							●			○	○	
							●			○	○	
							●			○	○	
●							●			○	○	
	●						●			○	○	
		●					●			○	○	
●			●				●			○	○	
	●			○			●			○	○	
					○		●			○	○	
	●	●				○	●					
							●			○	○	
							●		●			
	●								●			
												●

Electronic Modules EMG
Custom Circuits

EMG 10
 10 mm wide, 4 position

EMG 12
 12.5 mm wide, 4 position

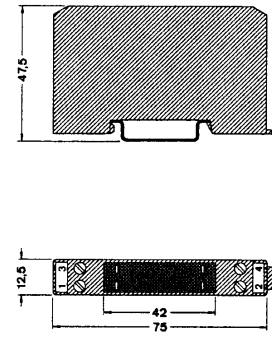
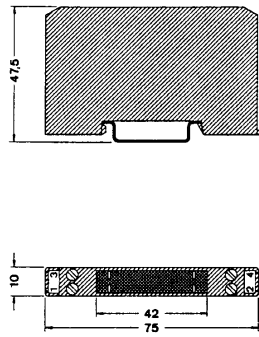
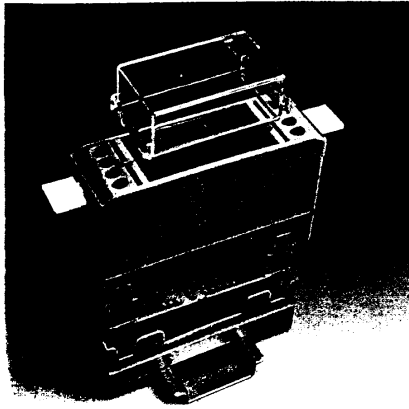

Custom circuit modules are designed with solder support points allowing free component installation. The empty modules (without printed circuit board and connector terminal blocks) offer the possibility of accommodating electronic circuits in dust shock proof, low cost housings.

	[mm ²]	AWG
Connection data, fine strand	2.5	12
Connection data, solid strand	4	12

	[mm ²]	AWG	[A]
Connection data, fine strand	2.5	12	
Connection data, solid strand	4	12	
Tab connection 6.3/2.8 x 0.8 mm, DIN 46 249:			20/5

Application	Type	Order No.	Pcs. Pkt.	Type	Order No.	Pcs. Pkt.
Module, for PCB insertion, without screw connection terminal block and cover	Grid 5 Grid 7.5	EMG 10-LG	29 47 74 7	10	EMG 12-LG	29 48 28 3
Module, for PCB insertion, without tab connection strip cover					EMG 12-LG-FSR	29 44 06 7
					EMG 12-LG-FSL	29 44 07 0
					EMG 12-LG-FS/FS	29 44 08 3
Custom circuit module, consisting of housing, connection terminal blocks MKDS 3 and PCB with points soldering in electronic components		EMG 10-B2	29 47 75 0	10	EMG 12-B2	29 48 30 6
Strip, to protect components from contact and termination. Available in green or clear. Dimensional drawing see page 9	clear clear green	EMG 10-H 7.5 mm clear EMG 10-H 15 mm clear EMG 10-H 52 mm green	29 47 76 3 29 47 77 6 29 47 78 9	10 10 10	EMG 12-H 7.5 mm clear EMG 12-H 15 mm clear EMG 12-H 52 mm green	29 47 11 6 29 48 29 6 29 47 12 9
PCB circuit board, mounting electronic components (see page 18)		P 1-EMG 10	29 47 79 2	5	P1-EMG 12	29 47 18 7
PCB circuit terminal blocks, grid 5, soldering into the PCB (see catalog page 290)	2 position 3 position 4 position	MKDS 3/2-EMG 10	17 12 34 2	50	MKDS 3/2	17 11 02 6
PCB circuit terminal blocks, grid 7.5, soldering into the PCB (see catalog page 293)	2 position					
Strip, with tab connection for soldering into the PCB	2 position				FLIS 2-(2-2.8-0.8) V	17 60 13 2

Component marking plate

narrow normal

Strip, to snap modules onto mounting rails, 1.4 mm (.445) wide

Strip for direct fitting 1.4 mm (.492) wide

Power loss dependent upon the cover height at 20° C
 EMG 10 fitted with zero spacing

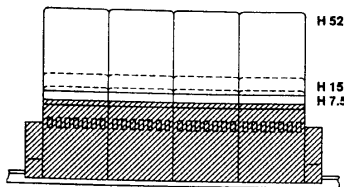

EMG 10 fitted with a spacing of ≥ 20 mm (.787)

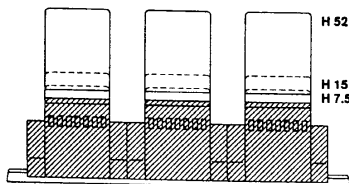

Power loss [W] at 20° C

	EMG 10	EMG 12	EMG 15	EMG 17	EMG 22
H 7.5 mm	0.9	1.2	1.2	1.3	1.4
H 15 mm	1.0	1.3	1.4	1.5	1.6
H 52 mm	1.5	2	2	2.1	2.3

Reduction factor dependent upon the ambient temperature

As the maximum permissible power loss is reduced with an increase in the ambient temperature, the listed reduction factor (K_i) must be taken into account when calculating the permissible power loss.

K _i	Ambient temperature [°C]				
	20	30	40	50	60
	1	0.8	0.64	0.51	0.41

Power loss [W] at 20° C

	EMG 10	EMG 12	EMG 15	EMG 17	EMG 22
H 7.5 mm	1.2	1.3	1.3	1.4	1.6
H 15 mm	1.4	1.5	1.5	1.6	1.8
H 52 mm	2.2	2.6	2.7	2.7	2.9

EMG 15
 15 mm wide,
 4 position with screw connection, grid 7.5
 6 position with screw connection, grid 5

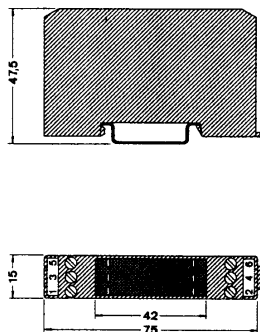

EMG 17
 17.5 mm wide,
 4 position with screw connection, grid 7.5
 6 position with screw connection, grid 5

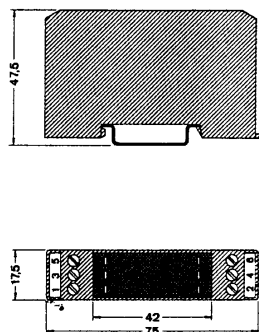

EMG 22
 22.5 mm wide, 8 position

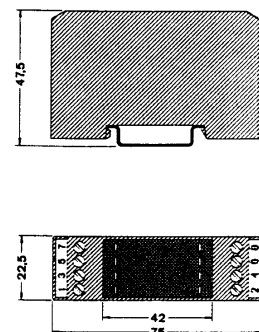

Connection data, fine strand [mm²] 2.5 AWG 12
 Connection data, solid strand [mm²] 4 AWG 12

Connection data, fine strand [mm²] 2.5 AWG 12
 Connection data, solid strand [mm²] 4 AWG 12

Connection data, fine strand [mm²] 2.5 AWG 12
 Connection data, solid strand [mm²] 4 AWG 12

Type	Order No.	Pcs. Pkt.	Type	Order No.	Pcs. Pkt.	Type	Order No.	Pcs. Pkt.
MG 15-LG	29 47 80 2	10	EMG 17-LG	29 46 07 8	10	EMG 22-LG	29 46 13 3	10
MG 15-LG-7.5	29 44 09 6	10	EMG 17-LG-7.5	29 44 10 6	10			
MG 15-B3	29 47 81 5	10	EMG 17-B3	29 46 08 1	10	EMG 22-B4	29 46 14 6	10
MG 15-H 7.5 mm clear	29 47 82 8	10	EMG 17-H 7.5 mm clear	29 46 09 4	10	EMG 22-H 7.5 mm clear	29 46 15 9	10
MG 15-H 15 mm clear	29 47 83 1	10	EMG 17-H 15 mm clear	29 46 10 4	10	EMG 22-H 15 mm clear	29 46 16 2	10
MG 15-H 52 mm green	29 47 84 4	10	EMG 17-H 52 mm green	29 46 11 7	10	EMG 22-H 52 mm green	29 46 17 5	10
P1-EMG 15	29 47 85 7	5	P1-EMG 17	29 46 12 0	5	P1-EMG 22	29 46 18 8	5
MKDS 3/3-EMG 15	17 12 69 8	50	MKDS 3/2	17 11 02 6	50	MKDS 3/2	17 11 02 6	50
			MKDS 3/3	17 11 03 9	50	MKDS 3/3	17 11 03 9	50
						MKDS 3/4	17 11 04 2	50
GMKDS 3/2-EMG 15	17 31 46 2	50	GMKDS 3/2	17 31 02 2	50			
EMG-GKS	29 47 03 5	50	EMG-GKS	29 47 03 5	50	EMG-GKS	29 47 03 5	50
EM-AD/NS 32	29 49 83 9	10	EM-AD/NS 32	29 49 83 9	10	EM-AD/NS 32	29 49 83 9	10

Power loss dependent upon the ambient temperature and cover height

$$P_{tu} = P_{vt} \times K_f$$

Explanations: P_v = power loss
 t_u = ambient temperature
 t = 20° C
 K_f = reduction factor

Example:
 Power loss at 40° C in EMG 12, mounted without pacing, cover height H 15 mm

$$P_{40^\circ C} = P_{v20^\circ C} \times K_f = 1.3 \text{ W} \times 0.64 = 0.83 \text{ W}$$

Dimensional drawing of electronic modules EMG

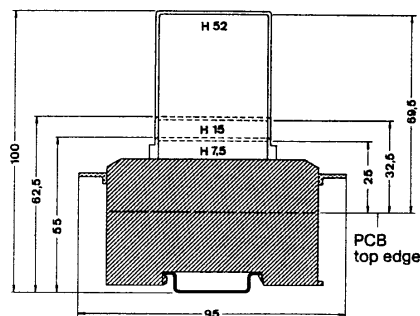

Design of the electronic modules EMG with tab connection

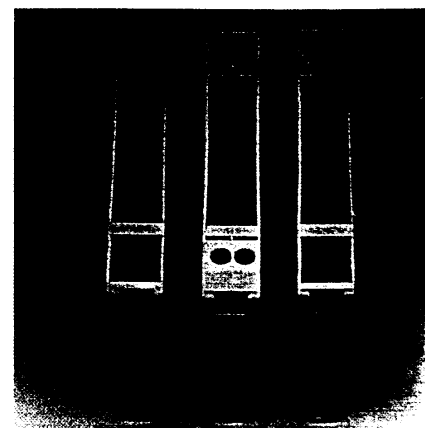

...FS/FS ...FSR ...FSL

mm to inch	
7.5	= (0.295)
10	= (0.394)
15	= (0.591)
20	= (0.787)
25	= (0.984)
30	= (1.181)
35	= (1.378)
40	= (1.575)
42	= (1.653)
47.5	= (1.870)
52	= (2.047)
55	= (2.165)
58	= (2.283)
62.5	= (2.461)
65	= (2.559)
68.5	= (2.700)
70	= (2.756)
75	= (2.953)
80	= (3.150)
85	= (3.347)
90	= (3.544)
95	= (3.740)
100	= (3.937)

Electronic Modules EMG
Custom Circuits

EMG 25
25 mm wide, 8 position

EMG 30
30 mm wide, 10 position

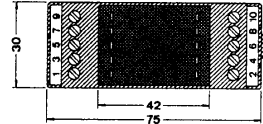
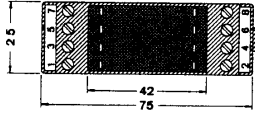
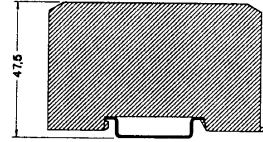
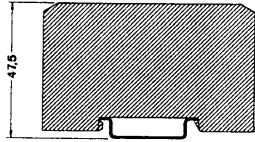

	[mm ²]	AWG
Connection data, fine strand	2.5	12
Connection data, solid strand	4	12

	[mm ²]	AWG
Connection data, fine strand	2.5	12
Connection data, solid strand	4	12

Description	Type	Order No.	Pcs./Pkt.	Type	Order No.	Pcs./Pkt.
Terminal block module , for PCB insertion with screw connection terminal block and cover	Grid 5	EMG 25-LG	29 48 31 9	5	EMG 30-LG	29 47 86 0
Custom circuit module , consisting of housing, connection terminal block MKDS 3 and PCB with points soldering in electronic components		EMG 25-B4	29 48 33 5	5	EMG 30-B5	29 47 87 3
Clear cover , to protect components from contact and contamination. Available in green or clear. Dimensional drawing see page 11	clear clear green	EMG 25-H 7.5 mm clear EMG 25-H 15 mm clear EMG 25-H 52 mm green	29 47 13 2 29 48 32 2 29 47 14 5	10 10 10	EMG 30-H 7.5 mm clear EMG 30-H 15 mm clear EMG 30-H 52 mm green	29 47 88 6 29 47 89 9 29 47 90 9
Printed circuit board , mounting electronic components (see page 18)		P1-EMG 25	29 47 19 0	5	P1-EMG 30	29 47 91 2
Terminal block , grid 5 soldering into the PCB (see catalog page 290)	2 position 3 position 4 position	MKDS 3/2 MKDS 3/3 MKDS 3/4	17 11 02 6 17 11 03 9 17 11 04 2	50 50 50	MKDS 3/2 MKDS 3/3 MKDS 3/4	17 11 02 6 17 11 03 9 17 11 04 2
Component marking plate	narrow normal	EMG-GKS	29 47 03 5	50	EMG-SGKS EMG-GKS	29 47 58 5 29 47 03 5
Mounting rail , to snap the module → mounting rails, mm (.445) wide		EM-AD/NS 32	29 49 83 9	10	EM-AD/NS 32	29 49 83 9
Mounting rail for direct fitting mm (.492) wide		EMG-ADM	29 48 59 7	10		

Power loss dependent upon the cover height at 20° C

Mounted with zero spacing

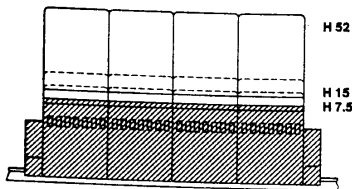

Power loss [W] at 20° C

	EMG 25	EMG 30	EMG 37	EMG 45	EMG 50
H 7.5 mm	1.4	1.5	1.6	2.0	2.3
H 15 mm	1.6	1.7	1.9	2.5	2.8
H 52 mm	2.3	2.4	2.6	3.5	3.8

Reduction factor dependent upon the ambient temperature

As the maximum permissible power loss is reduced with an increase in the ambient temperature, the listed reduction factor (K_i) must be taken into account when calculating the permissible power loss.

K _i	Ambient temperature [° C]				
	20	30	40	50	60
	1	0.8	0.64	0.51	0.41

Mounted with a spacing of ≥ 20 mm (.787)

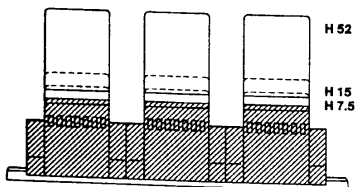

Power loss [W] at 20° C

	EMG 25	EMG 30	EMG 37	EMG 45	EMG 50
H 7.5 mm	1.6	1.7	1.8	2.4	2.6
H 15 mm	1.8	1.9	2.1	2.9	3.4
H 52 mm	2.9	3.1	3.5	4.4	4.8

EMG 37

37.5 mm wide, 14 position

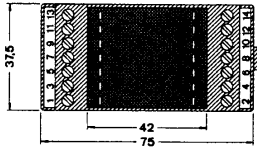
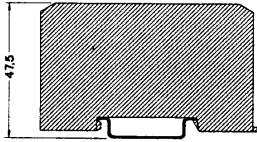

EMG 45

45 mm wide, 16 position

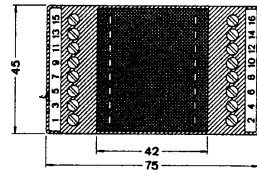
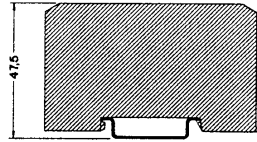

EMG 50

50 mm wide, 18 position

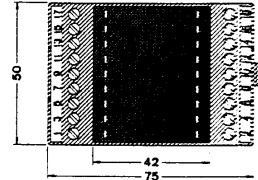
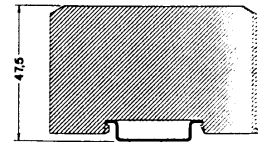

	[mm ²]	AWG
Connection data, fine strand	2,5	12
Connection data, solid strand	4	12

	[mm ²]	AWG
Connection data, fine strand	2,5	12
Connection data, solid strand	4	12

	[mm ²]	AWG
Connection data, fine strand	2,5	12
Connection data, solid strand	4	12

Type	Order No.	Pcs./Pkt.	Type	Order No.	Pcs./Pkt.	Type	Order No.	Pcs./Pkt.
MG 37-LG	29 47 05 1	5	EMG 45-LG	29 46 19 1	5	EMG 50-LG	29 47 24 2	5
MG 37-B7	29 47 06 4	5	EMG 45-B8	29 46 20 1	5	EMG 50-B9	29 47 25 3	5
MG 37-H 7.5 mm clear	29 47 15 8	5	EMG 45-H 7.5 mm clear	29 46 21 4	5	EMG 50-H 7.5 mm clear	29 47 32 5	5
MG 37-H 15 mm clear	29 47 16 1	5	EMG 45-H 15 mm clear	29 46 22 7	5	EMG 50-H 15 mm clear	29 47 33 3	5
MG 37-H 52 mm green	29 47 17 4	5	EMG 45-H 52 mm green	29 46 23 0	5	EMG 50-H 52 mm green	29 47 34 1	5
1-EMG 37	29 47 07 7	5	P1-EMG 45	29 46 24 3	5	P1-EMG 50	29 47 25 5	5
IKDS 3/2	17 11 02 6	50	MKDS 3/2	17 11 02 6	50	MKDS 3/2	17 11 02 6	50
IKDS 3/3	17 11 03 9	50	MKDS 3/3	17 11 03 9	50	MKDS 3/3	17 11 03 9	50
IKDS 3/4	17 11 04 2	50	MKDS 3/4	17 11 04 2	50	MKDS 3/4	17 11 04 2	50
MG-GKS	29 47 03 5	50	EMG-GKS	29 47 03 5	50	EMG-GKS	29 47 03 5	50

Power loss dependent upon the ambient temperature and cover height

$$P_{tu} = P_v t \times K_f$$

Explanations: P_v = power loss
 t = ambient temperature
 $t = 20^\circ\text{C}$
 K_f = reduction factor

Example: Power loss at 40°C in EMG 25, mounted without spacing, cover height H 15 mm

$$P_{40^\circ\text{C}} = P_v 20^\circ\text{C} \times K_f = 1.6\text{W} \times 0.64 = 1.02\text{W}$$

Dimensional drawing of electronic module EMG

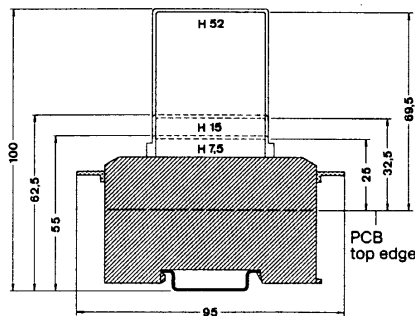

mm to inch	
7.5 = (.295)	50 = (1.968)
5 = (.590)	52 = (2.047)
7.5 = (.984)	55 = (2.165)
10 = (1.181)	62.5 = (2.461)
12.5 = (1.279)	69.5 = (2.736)
17.5 = (1.476)	75 = (2.953)
12 = (1.653)	95 = (3.740)
15 = (1.772)	100 = (3.937)

Electronic Modules EMG or Custom Circuits

EMG 75
75 mm wide, 28 position

EMG 90
90 mm wide, 34 position

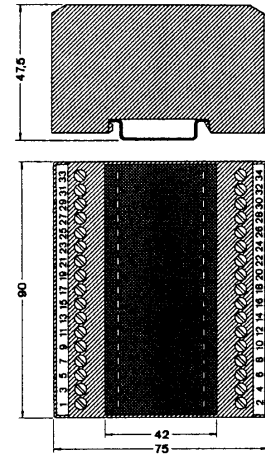
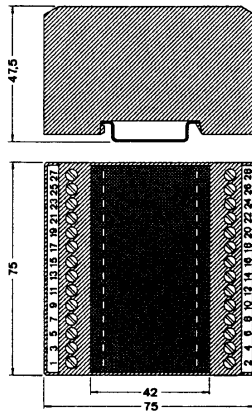

	[mm ²]	AWG
Connection data, fine strand	2.5	12
Connection data, solid strand	4	12

	[mm ²]	AWG
Connection data, fine strand	2.5	12
Connection data, solid strand	4	12

Description	Type	Order No.	Pcs./Pkt.	Type	Order No.	Pcs./Pkt.
Empty module, for PCB insertion without screw connection, terminal block and cover	Grid 5 EMG 75-LG	29 47 37 8	5	EMG 90-LG	29 46 25 6	2
Custom circuit module, consisting of housing, connection terminal block MKDS 3 and PCB with points soldering in electronic components	EMG 75-B14	29 47 38 1	2	EMG 90-B17	29 46 26 9	5
Cover, to protect components from contact and contamination. Available in green or clear. Dimensional drawing see page 13	clear EMG 75-H 7.5 mm clear clear EMG 75-H 15 mm clear green EMG 75-H 52 mm green	29 47 95 4 29 47 96 7 29 47 97 0	5 5 5	EMG 90-H 7.5 mm clear EMG 90-H 15 mm clear EMG 90-H 52 mm green	29 45 39 6 29 45 40 6 29 44 30 0	5 5 5
Printed circuit board, accepting electronic components (see page 18-19)	P1-EMG 75	29 47 39 4	5	P1-EMG 90	29 46 27 2	5
Printed circuit terminal blocks, grid 5, soldering into the PCB (see catalog page 290)	2 position MKDS 3/2 3 position MKDS 3/3 4 position MKDS 3/4	17 11 02 6 17 11 03 9 17 11 04 2	50 50 50	MKDS 3/2 MKDS 3/3 MKDS 3/4	17 11 02 6 17 11 03 9 17 11 04 2	50 50 50
Component marking plate	EMG-GKS	29 47 03 5	50	EMG-GKS	29 47 03 5	50

Power loss dependent upon the cover height at 20° C

Mounted with zero spacing

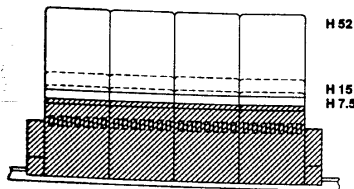

Power loss [W] at 20° C

	EMG 75	EMG 90	EMG 100	EMG 125	EMG 150
H 7.5 mm	3.3	4.1	-	-	-
H 15 mm	3.8	5.0	-	-	-
H 52 mm	4.9	6.1	-	-	-

Reduction factor dependent upon the ambient temperature

As the maximum permissible power loss is reduced with an increase in the ambient temperature, the listed reduction factor (K_i) must be taken into account when calculating the permissible power loss.

Ambient temperature [° C]

	20	30	40	50	60
K _i	1	0.8	0.64	0.51	0.41

Mounted with a spacing of ≥ 20 mm (.787)

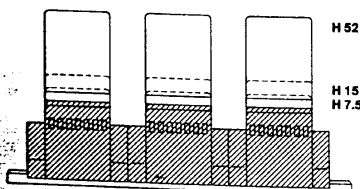

Power loss [W] at 20° C

	EMG 75	EMG 90	EMG 100	EMG 125	EMG 150
H 7.5 mm	3.9	4.6	-	-	-
H 15 mm	4.8	5.7	-	-	-
H 52 mm	5.8	7.1	-	-	-

EMG 100
100 mm wide, 38 position

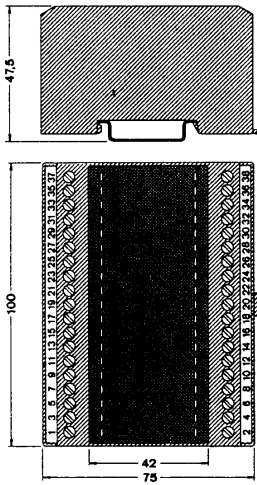

	[mm ²]	AWG
Connection data, fine strand	2.5	12
Connection data, solid strand	4	12

EMG 125
125 mm wide, 48 position

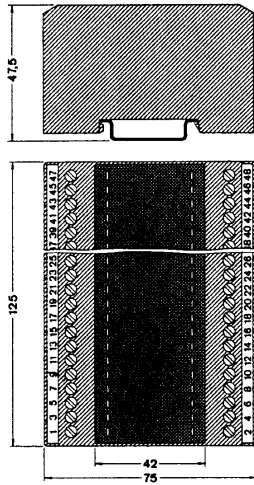

	[mm ²]	AWG
Connection data, fine strand	2.5	12
Connection data, solid strand	4	12

EMG 150
150 mm wide, 58 position

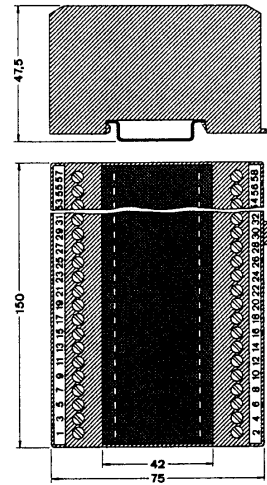

	[mm ²]	AWG
Connection data, fine strand	2.5	12
Connection data, solid strand	4	12

Type	Order No.	Pcs./Pkt.	Type	Order No.	Pcs./Pkt.	Type	Order No.	Pcs./Pkt.
EMG 100-LG	29 47 08 0	2	EMG 125-LG	29 47 98 3	2	EMG 150-LG	29 46 02 3	2
EMG 100-B19	29 47 09 3	2	EMG 125-B24	29 47 99 6	2	EMG 150-B29	29 46 03 6	2
on request			on request			on request		
P1-EMG 100	29 47 10 3	5	P1-EMG 125	29 46 01 0	5	P1-EMG 150	29 46 04 9	5
MKDS 3/2	17 11 02 6	50	MKDS 3/2	17 11 02 6	50	MKDS 3/2	17 11 02 6	50
MKDS 3/3	17 11 03 9	50	MKDS 3/3	17 11 03 9	50	MKDS 3/3	17 11 03 9	50
MKDS 3/4	17 11 04 2	50	MKDS 3/4	17 11 04 2	50	MKDS 3/4	17 11 04 2	50
EMG-GKS	29 47 03 5	50	EMG-GKS	29 47 03 5	50	EMG-GKS	29 47 03 5	50

Power loss dependent upon the ambient temperature and cover height

$$P_{tu} = P_{vt} \times K_j$$

Explanations: P_v = power loss
 t_u = ambient temperature
 $t = 20^\circ\text{C}$
 K_j = reduction factor

Example:
 Power loss at 40°C in EMG 90; mounted without spacing; cover height H 15 mm

$$P_{v40^\circ\text{C}} = P_v 20^\circ\text{C} \times K_j = 5.0\text{W} \times 0.64 = 3.2\text{W}$$

Dimensional drawing of electronic module EMG

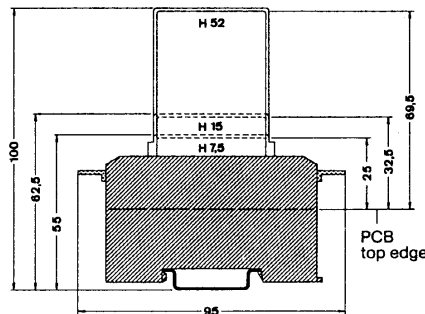

mm to Inch			
7.5	= (.295)	62.5	= (2.461)
15	= (.590)	69.5	= (2.736)
25	= (.984)	75	= (2.953)
32.5	= (1.279)	90	= (3.543)
42	= (1.653)	95	= (3.740)
47.5	= (1.870)	100	= (3.937)
52	= (2.047)	125	= (4.921)
55	= (2.165)	150	= (5.905)



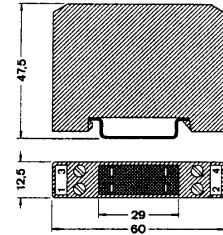
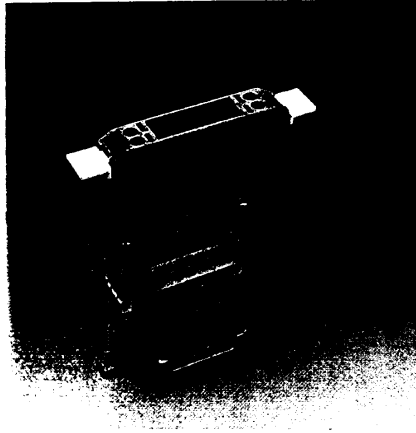

**Electronic Module EMK
for Custom Circuits**

EMK 12
12.5 mm wide, 4 positions



The special feature of the electronic module EMK is its compact design with only 12.5 mm construction width.

	[mm ²]	AWG
Connection data, fine strand	2.5	12
Connection data, solid strand	4	12

Description	Type	Order No.	Pcs. Ptk.
Empty module , for PCB insertion, without screw connection terminal block	EMK 12-LG	29 48 98 2	10
Custom circuit module , consisting of housing, connection terminal blocks MKDS 3 and PCB with points for soldering in electronic components	EMK 12-B2	29 48 99 5	10
Printed circuit board , to mount electronic components (see page 19)	P1-EMK 12	29 47 01 9	5
Printed circuit terminal blocks , for soldering into the PCB (also see catalog page 290)	2 positions MKDS 3/2	17 11 02 6	50
Equipment marking plate	 EMG-GKS	29 47 03 5	50
Adaptor , to snap the module on  mounting rails, 11.4 mm (.445) wide	 EM-AD/NS 32	29 49 83 9	10
Adaptor for direct fitting 12.5 mm (.492) wide	 EMG-ADM	29 48 59 7	10

mm to inch
12.5 = (.492)
29 = (1.142)
47.5 = (1.870)
60 = (2.362)



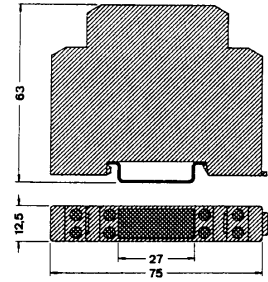
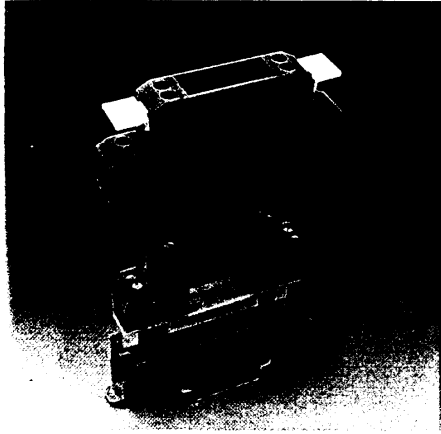

Double Level Electronic Module EMD for Custom Circuits

EMD 12
12.5 mm wide, 8 position



The module type EMD offers 8 connection points in a double level arrangement with a construction width of only 12.5 mm.

	[mm ²]	AWG
Connection data, fine strand	2.5	12
Connection data, solid strand	4	12

Description	Type	Order No.	Pcs/Pkt
Empty module , for PCB insertion, without screw connection terminal blocks and cover	EMD 12-LG	29 47 40 4	10
Cover , to protect components from contact and contamination	on request		
Printed circuit terminal blocks , for soldering in the PCB, bottom lower level	2 positions MKDS 3/2	17 11 02 6	50
Printed circuit terminal blocks , for soldering in the PCB upper level	2 positions MKKDSH 3/2	17 21 04 5	50
Spacer , plastic for the printed circuit terminal blocks MKKDSH	AH-MKKDSH 3/2	17 21 78 6	50
Equipment marking plate	 EMG-GKS	29 47 03 5	50
Adaptor , to snap the modules on  mounting rails, 11.4 mm (.445) wide	 EM-AD/NS 32	29 49 83 9	10
Adaptor for direct fitting 12.5 mm (.492) wide	 EMG-ADM	29 48 59 7	10

mm to inch
12.5 = (.492)
27 = (1.063)
63 = (2.480)
75 = (2.953)

**Double Level
Electronic Module EME
for Custom Circuits**

EMC 45
45 mm wide, 16 position

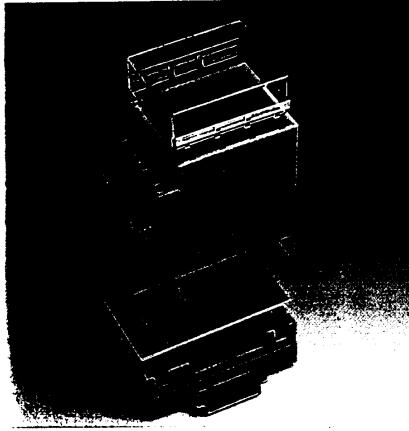

The module type EME offers an enlarged custom circuit space. The 16 connection points are arranged on only one side of the module on both levels as input or output terminal blocks.

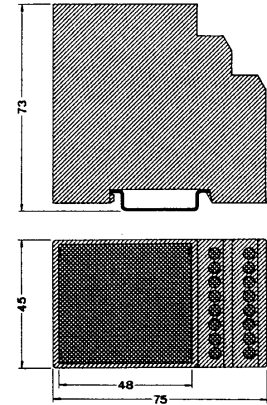

	[mm ²]	AWG
Connection data, fine strand	2.5	12
Connection data, solid strand	4	12

Description	Type	Order No.	Pcs./Ptk.
Empty module, for PCB insertion, without screw connection terminal blocks and cover	EME 45-LG	29 44 11 9	10
Cover, to protect components from contact and contamination. Available in green or clear, see below for dimensions	clear clear green	EMG 50-H 7.5 mm clear EMG 50-H 15 mm clear EMG 50-H 52 mm green	5 5 5
Printed circuit terminal blocks, grid 5, for soldering in the PCB	2 position 3 position	MKKDSG 3/2 MKKDSG 3/3	50 50

Dimensional drawing of electronic module EME

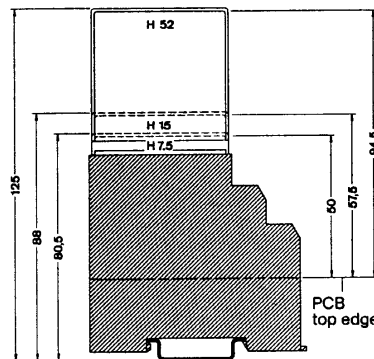

mm to inch

7.5	= (.295)
15	= (.590)
45	= (1.772)
48	= (1.890)
50	= (1.968)
52	= (2.047)
57.5	= (2.264)
73	= (2.874)
75	= (2.953)
80.5	= (3.169)
88	= (3.464)
94.5	= (3.720)
125	= (4.921)

**Electronic Module EMH
for Custom Circuits**

EMH 23
25 mm wide, 14 position

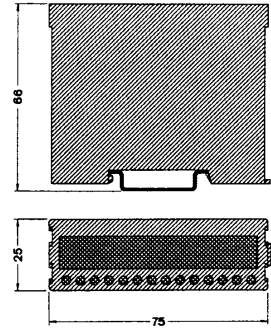
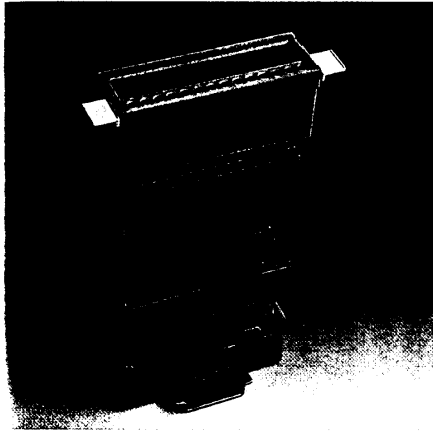

These component housings with front connection system have a variable construction height. With a construction width of only 25 mm, the required module height and thus the custom circuit space can be flexibly varied by the use of intermediate elements. In this manner the vertically arranged PCB in the module can be matched to the individual switching task. 14 individual printed circuit terminals with front connection are fitted in the module. Each connection point can also be allocated a light indicator.

	[mm ²]	AWG
Connection data, fine strand	1.5	16
Connection data, solid strand	1.5	16

Description	Type	Order No.	Pcs/Pkt
Empty module , for PCB insertion, without screw connection terminal blocks	EMH 25-LG	29 44 12 2	10
Intermediate elements , for the empty module intermediate element, 18 mm high intermediate element, 30 mm high	EMH 25-ZE 18 EMH 25-ZE 30	29 44 13 5 29 44 14 8	10 10
Single printed circuit terminal block , for front connection, 5 mm grid, pin spacing 5 mm pin spacing 10 mm	FRONT1.5H/SA5 FRONT1.5H/SA10	17 00 00 8 17 00 04 0	50 50
End cover , necessary at the end of a terminal block row, 2,5 mm thick, color: green	D-FRONT1.5H	17 00 02 4	50
Equipment marking plate	EMG-GKS	29 47 03 5	50
Adaptor to snap the module on mounting rails, 11.4 (.445) mm wide	EM-AD/NS 32	29 49 83 9	10
Adaptor for direct fitting 12.5 (.492) mm wide	EMG-ADM	29 48 59 7	10

Dimensional drawing of electronic module EMH

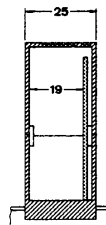

mm to inch

19	= (.748)
25	= (.984)
66	= (2.598)
75	= (2.953)

Printed Circuit Board Layouts for the Electronic Modules EMG, EMK, EMD, EME and MH in a 1:1 Scale

Technical data for the printed circuit board

Material: Epoxy glass filament fabric
 Thickness: 1.5 mm (.026) thick as per DIN 40802
 Surface plating: 70 µm
 Drill diameter: 1.3 mm (.051) dia. for the solder pins of the screw and tab connections
 Drill diameter: 0.9 mm (.035) dia. for components as per DIN 40801 page 2
 Creepage distance: 250 V AC as per VDE 0110/Gr. C VDE 0160

TF: Top face
 BF: Bottom face
 In: Internal

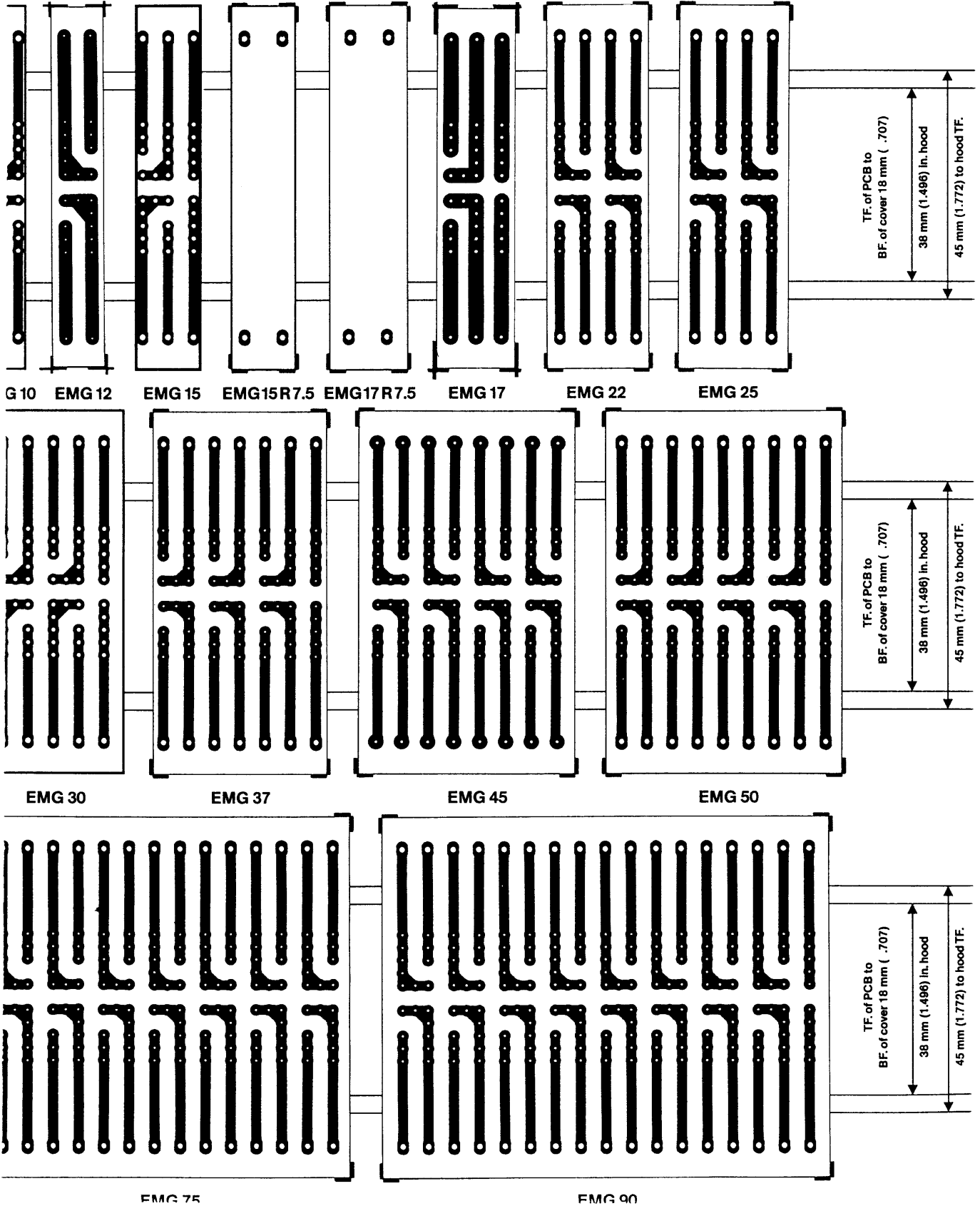

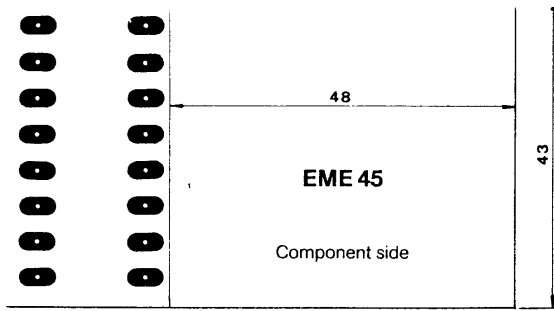

mm to inch
 10 = (.394)
 27 = (1.063)
 29 = (1.142)
 38 = (1.496)
 43 = (1.693)
 47 = (1.850)
 48 = (1.890)
 60 = (2.362)

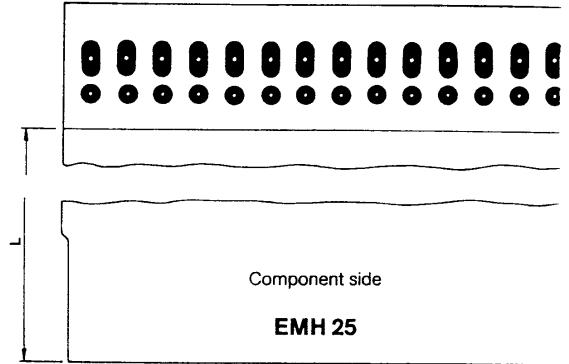
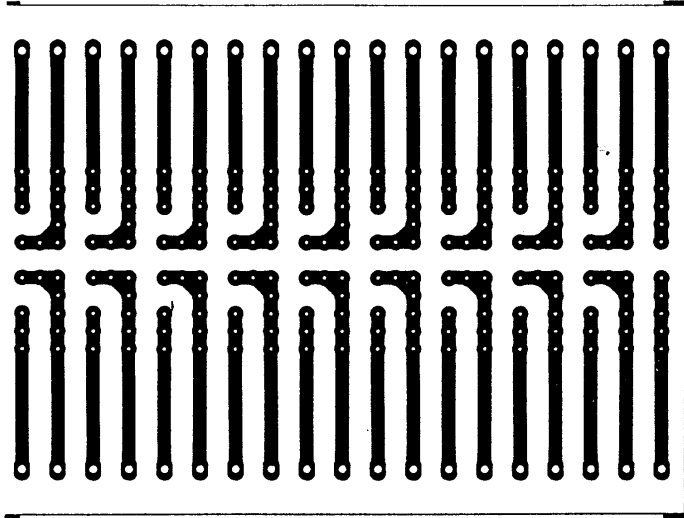
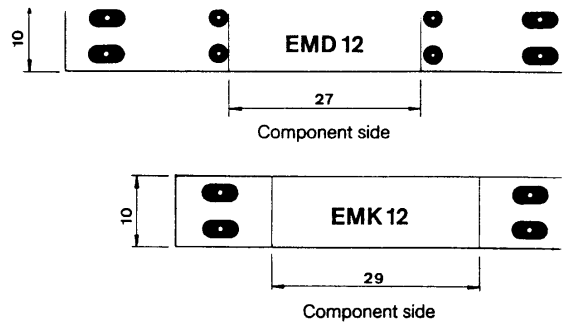

List of electronic modules EMH

Total length	Width	Component length L	Width
53 mm (2.087)	72 mm (2.835)	35 mm (1.378)	72 mm (2.83)
71 mm (2.795)	72 mm (2.835)	53 mm (2.087)	72 mm (2.83)
83 mm (3.268)	72 mm (2.835)	65 mm (2.559)	72 mm (2.83)
101 mm (3.976)	72 mm (2.835)	83 mm (3.268)	72 mm (2.83)
113 mm (4.449)	72 mm (2.835)	95 mm (3.740)	72 mm (2.83)
131 mm (5.157)	72 mm (2.835)	113 mm (4.449)	72 mm (2.83)
143 mm (5.629)	72 mm (2.835)	125 mm (4.921)	72 mm (2.83)

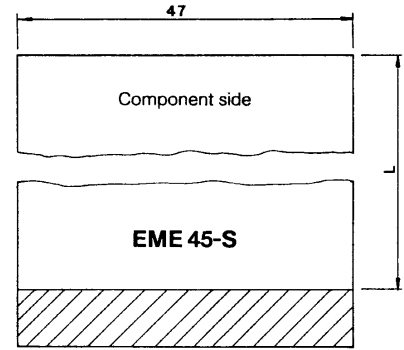
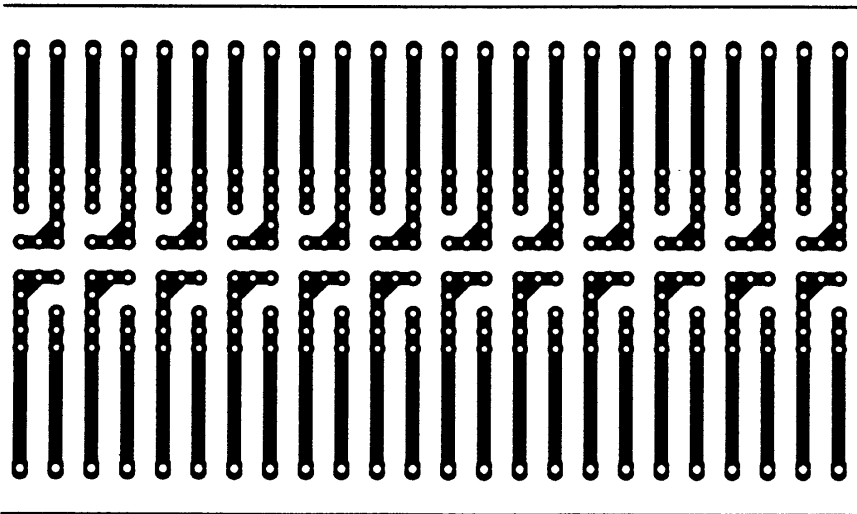

PCB dimensions when using different covers

Total length	Width	Component length L	Width	Covers
49 mm (1.929)	47 mm*	41 mm (1.614)	47 mm*	EMG 50-H 7
57 mm (2.244)	47 mm*	49 mm (1.929)	47 mm*	EMG 50-H 1
94 mm (3.701)	47 mm*	36 mm (1.417)	47 mm*	EMG 50-H 5
	*(1.850)		*(1.850)	
	*(1.850)		*(1.850)	
	*(1.850)		*(1.850)	

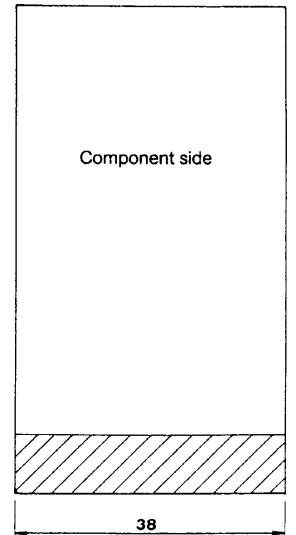
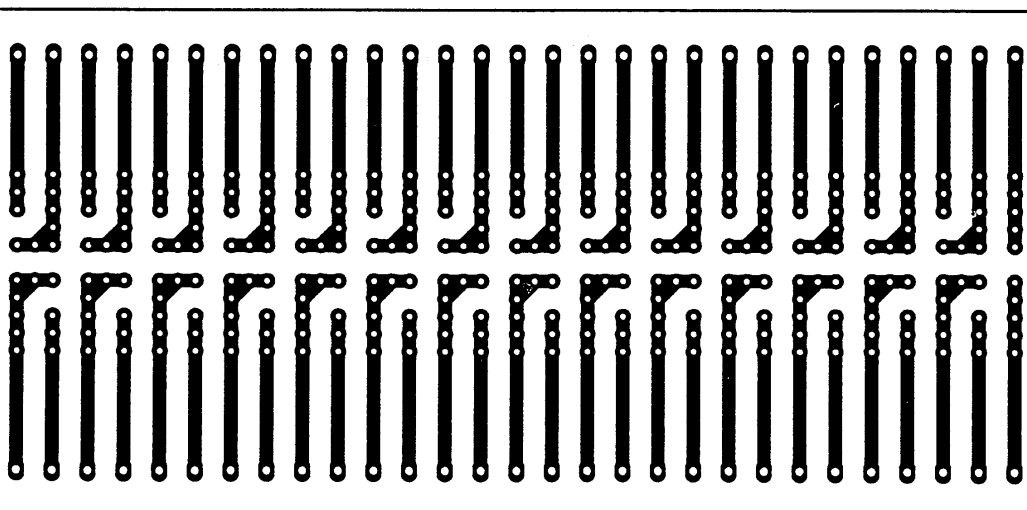

Electronic Component Housings UEG Custom Circuits

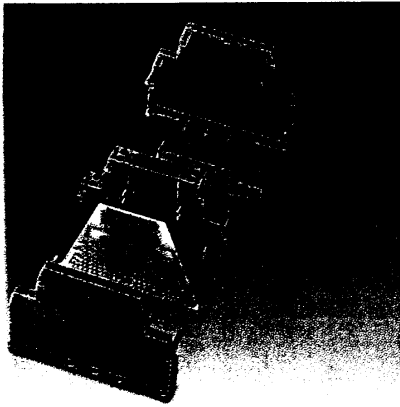

The electronic component housing UEG is produced in two widths (20 and 30 mm) and offers screw or tab connections. The housing can be engaged on commercially available DIN mounting rails.

The functionable housing concept permits an economical production of series products. In one work cycle the basic element of the connections and the custom circuit PCB are machine soldered and subsequently securely engaged with the housings to form a housing. Due to the flexible level 8 or 16 screw or tab connections and the installation of one or two printed circuit boards even complex electronic circuits can be accommodated in the housing.

For laboratory samples and small series a universal printed circuit board is available.

For technical data and of the printed circuit board dimensions refer to page 26.

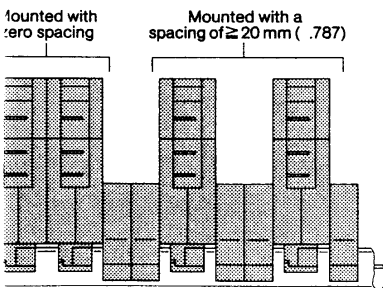

Type of moldings

Krilen = Polyamide 6.6, see catalog page 12
Color: green

Marking and mounting material see catalog page 10

UEG 20 8 position component holder with screw connection

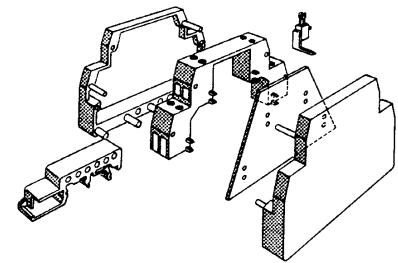
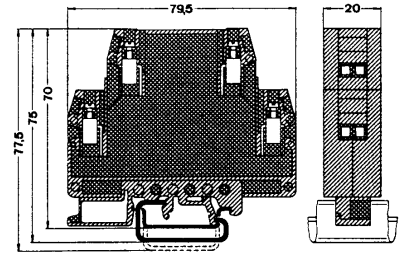

	Solid	fine strand, AWG	I [A]	VAC [V]
Screw connection	4	2.5	12	10* 250*
Tab connection: 6.3/2.8 mm				
UEG 20-FS/FS				10/5* 500*
UEG 30/1-FS/FS				10/5* 500*
UEG 30/2-FS/FS				10/5* 250*

* The rated voltage applies to fully insulated receptacles and free solder connection. Voltage and current values are affected by the configuration of the printed circuit board.



Description

Electronic component housing, 20 mm wide, complete, equipped with 4 screw or 4 tab connections per side, for one printed circuit board

Electronic component housing, 30 mm wide, complete, equipped with 4 screw or 4 tab connections per side, for one printed circuit board

Electronic component housing, 30 mm wide, complete, equipped with 8 screw or 8 tab connections per side, for two printed circuit boards

Printed circuit board, for custom circuiting electronic components (see page 26)

Plastic sheath, as shock protection, slide onto conductor for 6.3 mm receptacles before fitting for 2.8 mm receptacles

Wire bridge, 50 position, divisible, for bridging identical inputs and outputs, 0.5 mm², insulation: black or gray



UEG 20

Type	Order No.	Pcs. Pkt.
UEG 20	27 90 21 1	10
P1-UEG	27 90 22 4	10
DB 50-90 black	28 20 91 6	1
DB 50-90 grey	28 20 92 9	1

Power loss as a function of ambient temperature

Mounted with zero spacing
Power loss [W] at 20° C

UEG 20	UEG 30/1	UEG 30/2	UEG 20-FS/FS	UEG 30/1-FS/FS	UEG 30/2-FS/FS
4	4	4	4.8	4.8	4.8

Mounted with spacing of ≥ 20 mm
Power loss [W] at 20° C

UEG 20	UEG 30/1	UEG 30/2	UEG 20-FS/FS	UEG 30/1-FS/FS	UEG 30/2-FS/FS
6.4	7.2	7.2	8	8	8

Reduction factor dependent upon the ambient temperature

As the maximum permissible power loss is reduced with an increase in the ambient temperature, the listed reduction factor (K_t) must be taken into account when calculating the permissible power loss.

Ambient temperature [° C]

K _t	20	30	40	50	60	70	80
	1	0.78	0.61	0.48	0.37	0.29	0.23

Power loss dependent upon the ambient temperature

$$P_{vtu} = P_{vt} \times K_t$$

Explanations: P_v = power loss
t_u = ambient temperature
t = 20° C
K_t = reduction factor

Example: Power loss at 40° C in UEG 20, mounted without spacing

$$P_v 40^\circ C = P_v 20^\circ C \times K_t = 4 W \times 0.61 = 2.44 W$$

UEG 30

16 position component holder with screw connection

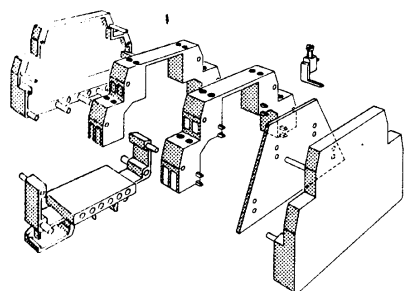
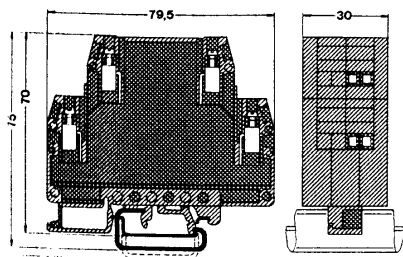

EG 30/1

UEG 20-FS/FS

8 position component holder with slotted 6.3/2.8 mm tab connection

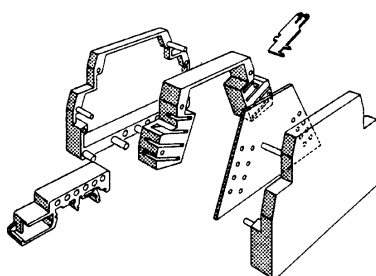
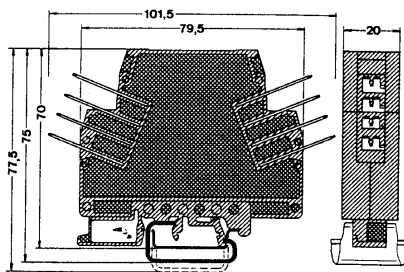

UEG 20-FS/FS

UEG 30-FS/FS

8 and 16 position component holder with slotted 6.3/2.8 mm tab connection

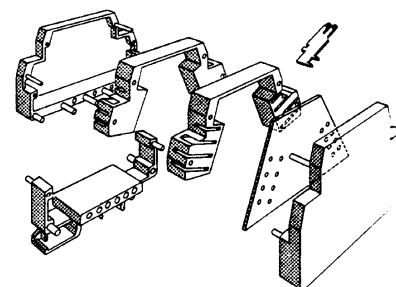
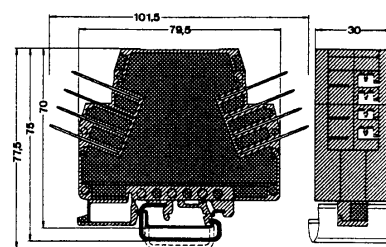

UEG 30/1-FS/FS

Part No.	Order No.	Pcs. Pkt.	Type	Order No.	Pcs. Pkt.	Type	Order No.	Pcs. Pkt.
			UEG 20-FS/FS	27 90 26 6	10			
EG 30/1	27 90 87 1	10				UEG 30/1-FS/FS	27 90 88 4	10
EG 30/2	27 90 24 0	10				UEG 30/2-FS/FS	27 90 27 9	10
I-UEG	27 90 22 4	10	P1-UEG-FS/FS	27 90 42 8	10	P1-UEG-FS/FS	27 90 42 8	10
			PT/FS-6.3	06 04 70 7	100	PT/FS-6.3	06 04 70 7	100
			PT/FS-2.8	14 06 70 0	100	PT/FS-2.8	14 06 70 0	100
B 50-90 black	28 20 91 6	1						
B 50-90 grey	28 20 92 9	1						

Maximum component height on printed circuit board

UEG 20 with 1 printed circuit board, max. 8 positions	UEG 30/1 increased internal space with 1 printed circuit board, max. 8 position	UEG 30/2 increased internal space with 2 printed circuit boards, mirror image arrangement, max. 16 positions
---	---	--

Maximum component height on printed circuit board

UEG 20-FS/FS with 1 printed circuit board, max. 8 positions	UEG 30/1-FS/FS increased internal space with 1 printed circuit board, max. 8 position	UEG 30/2-FS/FS increased internal space with 2 printed circuit boards, mirror image arrangement, max. 16 positions
---	---	--

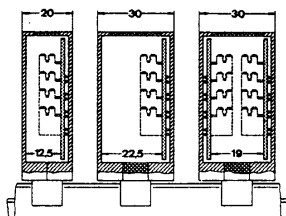
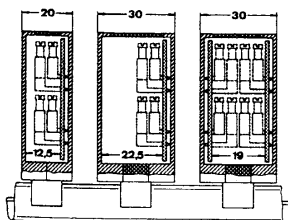

mm to inch
 20 = (.787)
 30 = (1.181)
 70 = (2.756)
 75 = (2.953)
 77.5 = (3.051)
 79.5 = (3.130)
 101.5 = (3.996)

Electronic Component Housings UEGM for Custom Circuits

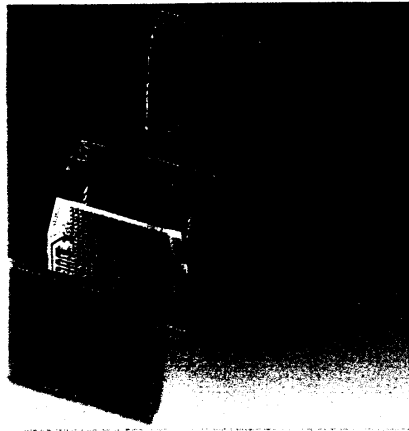

The electronic component housings UEGM supplement the UEG range and offer an enlarged internal area. The housing is available in the widths 22.5 – 25 and 40 mm. They can be individually provided with 3 screw and/or tab connections. The housings snap on commercially available DIN EN mounting rails.

The functionable housing concept permits the economical production of series products. In one work cycle the basic element machine soldered with the connections of the custom circuited PCB and subsequently securely engaged with the housing shell to form a housing. Due to the double shell 6 or 12 screw or tab connections and the use of one or two printed circuit boards a complex electronic circuits can be accommodated in the housing.

For laboratory samples and small series a universal printed circuit board is available.

For technical data and printed circuit board dimensions refer to page 26.

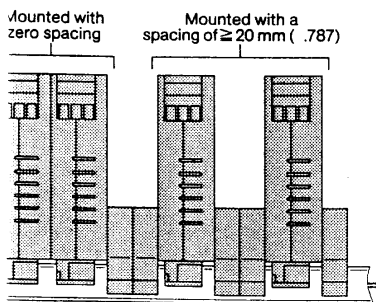

Type of moldings

Material = Polyamide 6.6, see catalog page 12
Color: green

Marking and mounting material see catalog page 10

UEGM 6 position component holder with screw connection

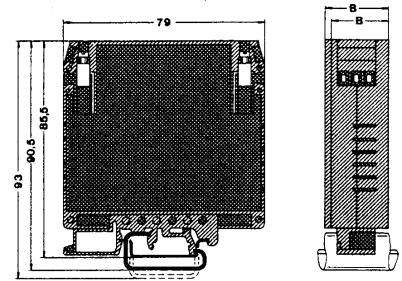

W=22.5 with UEGM 22.5
W=25 with UEGM 25

	Solid, fine strand, AWG [mm ²]	I [A]	VAC [V]
Screw connection	4 2.5 12 10*	250*	250*
Tab connection: 6.3/2.8 mm		10/5*	250*

*The rated voltage applies to fully insulated receptacles and free solder connection. Voltage and current values are affected by the configuration of the printed circuit board.

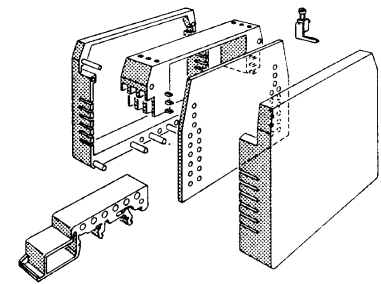

UEGM 25



Description

Electronic component housing, 22.5 mm wide, complete, equipped with 3 screw or 6 tab connections per side, for one printed circuit board

Electronic component housing, as above, however, 25 mm wide

Electronic component housing, as above, however 40 mm wide

Electronic component housing, 40 mm wide, complete, equipped with 6 screw or 12 tab connections per side, for two printed circuit boards.

Printed circuit board, for custom circuiting electronic components (see page 26)

Metal part for tab connection, to increase the number of positions

Plastic sheath, as shock protection, slide onto conductor for 6.3 mm receptacles before fitting for 2.8 mm receptacles

Wire bridge, 50 position, divisible for bridging identical inputs and outputs, 0.5 mm², insulation: black and grey



Power loss as a function of ambient temperature

Mounted with zero spacing
Power loss [W] at 20° C

UEGM 22.5	UEGM 25	UEGM 40/1	UEGM 40/2	UEGM 22.5-FS/FSFS/FSFS/FSFS/FS	UEGM 25-FS/FSFS/FSFS/FSFS/FS	UEGM 40/1-FS/FSFS/FSFS/FSFS/FS	UEGM 40/2-FS/FSFS/FSFS/FSFS/FS
4	4	5.2	5.2	4	4	5.2	5.2

Mounted with spacing of ≥ 20 mm
power loss [W] at 20° C

UEGM 22.5	UEGM 25	UEGM 40/1	UEGM 40/2	UEGM 22.5-FS/FSFS/FSFS/FSFS/FS	UEGM 25-FS/FSFS/FSFS/FSFS/FS	UEGM 40/1-FS/FSFS/FSFS/FSFS/FS	UEGM 40/2-FS/FSFS/FSFS/FSFS/FS
10	10	11.2	11.2	10	10	11.2	11.2

Type	Order No.	Pcs. Pkt.
UEGM 22.5	27 92 00 2	10
UEGM 25	27 92 01 5	10
P1-UEGM	27 92 10 9	10
UEG-MT-FS	27 90 38 9	100
PT/FS-6.3	06 04 70 7	100
PT/FS-2.8	14 06 70 0	100
DB 50-90 black	28 20 91 6	1
DB 50-90 grey	28 20 92 9	1

Reduction factor dependent upon the ambient temperature

As the maximum permissible power loss is reduced with an increase in the ambient temperature, the listed reduction factor (K_t) must be taken into account when calculating the permissible power loss.

Ambient temperature [° C]

K _t	20	30	40	50	60	70	80
	1	0.8	0.64	0.51	0.41	0.33	0.26

Power loss dependent upon the ambient temperature

$$P_{vtu} = P_v \times K_t$$

Explanations: P_v = power loss
t_u = ambient temperature
t = 20° C
K_t = reduction factor

Example: Power loss at 40° C in UEGM 25, mounted without spacing

$$P_v 40^\circ C = P_v 20^\circ C \times K_t = 4 \text{ W} \times 0.64 = 2.56 \text{ W}$$

UEGM
and 12 position component holder with screw connection

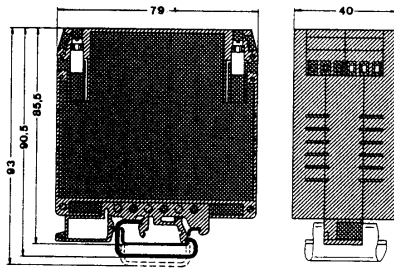

UEGM 13/13
12 position component holder with slotted 6.3/2.8 tab connection

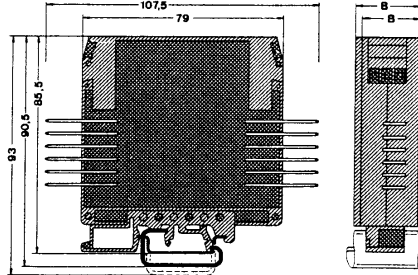

W=22.5 with UEGM 22.5
W=25 with UEGM 25

UEGM 13/13
12 and 24 position component holder with slotted 6.3/2.8 mm tab connection

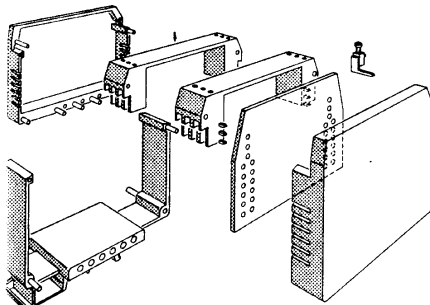
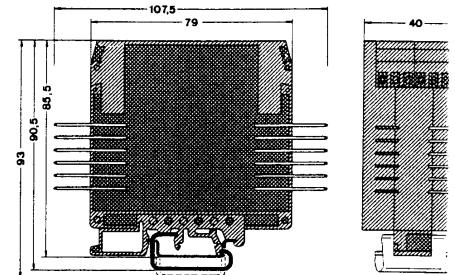

EGM 40/1

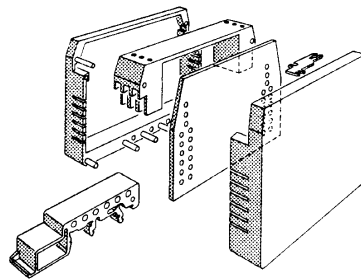

UEGM 25-FS/FS

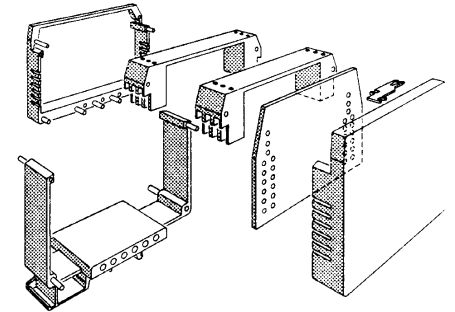

UEGM 40/1-FS/FS

pe	Order No.	Pcs. Pkt.	Type	Order No.	Pcs. Pkt.	Type	Order No.	Pcs. Pkt.
			UEGM 22.5-FS/FS	27 92 07 3	10			
			UEGM 25-FS/FS	27 92 08 6	10			
EGM 40/1	27 92 11 2	10				UEGM 40/1-FS/FS	27 92 12 5	10
EGM 40/2	27 92 02 8	10				UEGM 40/2-FS/FS	27 92 09 9	10
P1-UEGM	27 92 10 9	10	P1-UEGM	27 92 10 9	10	P1-UEGM	27 92 10 9	10
EG-MT-FS	27 90 38 9	100						
PT/FS-6.3	06 04 70 7	100	PT/FS-6.3	06 04 70 7	100	PT/FS-6.3	06 04 70 7	100
PT/FS-2.8	14 06 70 0	100	PT/FS-2.8	14 06 70 0	100	PT/FS-2.8	14 06 70 0	100
3 50-90 black	28 20 91 6	1						
8 50-90 grey	28 20 92 9	1						

179-054.

Maximum component height on printed circuit board

UEGM 22.5 with 1 printed circuit board, 6 positions	UEGM 25 with 1 printed circuit board, 6 position	UEGM 40/1 increased internal space with 1 printed circuit board, 6 positions	UEGM 40/2 increased internal space with 2 printed circuit boards, image arrangement, 12 position
---	--	--	--

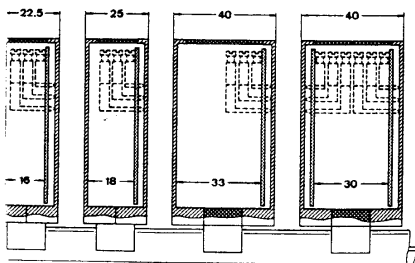

Maximum component height on printed circuit board

UEGM 22.5-FS/FS with 1 printed circuit board, 12 positions	UEGM 25-FS/FS with 1 printed circuit board, 12 positions	UEGM 40/1-FS/FS increased internal space with 1 printed circuit board, 12 position	UEGM 40/2-FS/FS increased internal space with 2 printed circuit boards, image arrangement, 24 position
--	--	--	--

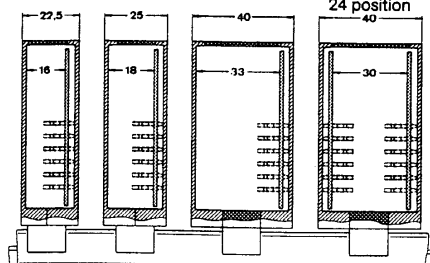

mm to inch

16	= (.630)
18	= (.709)
22.5	= (.886)
25	= (.984)
30	= (1.181)
33	= (1.299)
40	= (1.575)
79	= (3.110)
85.5	= (3.366)
90.5	= (3.563)
93	= (3.661)
107.5	= (4.232)

Electronic Component Housing with 12 Position COMBICON Header UEGM-MSTB

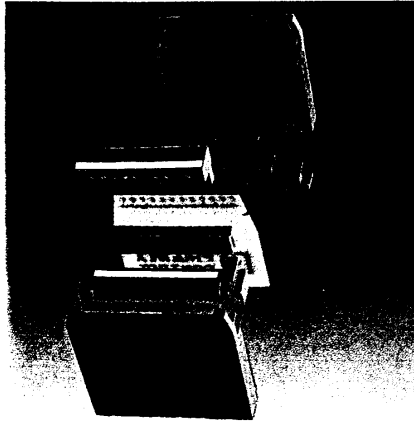

The special feature of this 25 mm wide electronic component housing UEGM-MSTB is the plug-in connection through a COMBICON plug connector 2 or 12 position. COMBICON plugs can be optionally integrated in the housing pin strip.

The COMBICON connection points can individually be fitted with 3 mm dia. LEDs (lead length 30 mm (1.181)). The LED break-outs in the housing not required can be closed with plugs. If several component housings with the same plug arrangement are arranged next to each other, the individuality of the COMBICON plugs can be ensured by keying. For this purpose the keying pin CS-MSTB is inserted in the socket and the corresponding contact pin is broken off with the keying clippers. Using a blind piece MSTB-BL individual contact points can be covered in order to achieve a compartment formation on the pin strip.

The electronic component housing UEGM-MSTB snaps on commercially available DIN EN mounting rails.

For technical data and printed circuit board dimensions refer to page 27.

Power loss dependent upon the ambient temperature see page 22.
 The same power loss is applicable as with electronic component housings UEGM 25.

Type of moldings

Material = Polyamide 6.6, see catalog page 12
 Color: green

Marking and mounting material see catalog page 10

Maximum component height on the printed circuit board

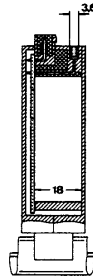

UEGM-MSTB Component housing with COMBICON connection

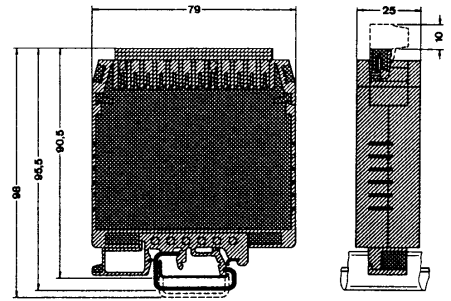

Connection data	Solid, [mm ²]	fine strand, AWG	I [A]	VAC [V]
	2.5	2.5	14	12*
			12*	250*

* Voltage and current values are affected by the configuration of the printed circuit board.

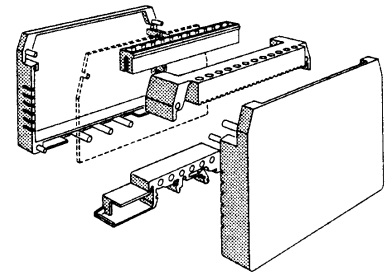

Description	No. of positions	Type	Order No.	Pcs. Pkt.
Electronic component housing, with 12 position COMBICON pin strip, additionally fitted with 3 mm LED light indicator	12	UEGM-MSTB	27 81 45 3	10
COMBICON header, 5.08 mm grid for other COMBICON plug types see catalog page 302	2	MSTB 1.5/2-ST-5.08	17 57 01 9	50
	3	MSTB 1.5/3-ST-5.08	17 57 02 2	50
	4	MSTB 1.5/4-ST-5.08	17 57 03 5	50
	5	MSTB 1.5/5-ST-5.08	17 57 04 8	50
	6	MSTB 1.5/6-ST-5.08	17 57 05 1	50
	7	MSTB 1.5/7-ST-5.08	17 57 06 4	50
	8	MSTB 1.5/8-ST-5.08	17 57 07 7	50
	9	MSTB 1.5/9-ST-5.08	17 57 08 0	50
	10	MSTB 1.5/10-ST-5.08	17 57 09 3	50
	12	MSTB 1.5/12-ST-5.08	17 57 11 6	50

- Blind piece, for coding and compartment formation, plugs onto pole pin, green plastic
- Keying pin, engages in the plug contact remove counter pole in the housing, red plastic
- Plugs, for closing LED positions not in use
- Keying pliers, for snipping contact pins, if the keying pin CS-MSTB is fitted in the plug
- Marking card, with 25 pcs. 10 section white marking strips, self adhesive, sufficient for 250 terminals
 - unprinted: for use with marker pen
 - printed: with 25 identical decades
 card, with 50 pcs. 5 section marking strips sufficient for 250 terminals
 - printed: with L1, L2, L3, N, PE U, V, W, N, +



MSTB-BL	17 55 47 7	100
CS-MSTB	17 59 99 4	100
UEGM-MSTB-BS	27 81 46 6	60
MSTB-ZA	17 67 60 1	1
a) SKS 5: unprinted	14 01 20 0	10
b) SKS 5: 1-10 SKS 5: 11-20 etc. up to SKS 5: 191-200	14 01 21 3	
c) SKS 5: L1-N, PE SKS 5: U-N	14 02 27 0 14 01 28 4	
B-Pen	10 51 99 3	1

Note:
 COMBICON plug connectors may only be actuated when not under power. If for technical operating reasons smaller loads are to be switched, experience values are available upon request.

mm	to inch
3.6	= (.142)
10	= (.394)
18	= (.709)
25	= (.984)
79	= (3.110)
90.5	= (3.563)
95.5	= (3.760)
98	= (3.858)

Electronic Component housings for European format Cards UEG-EU

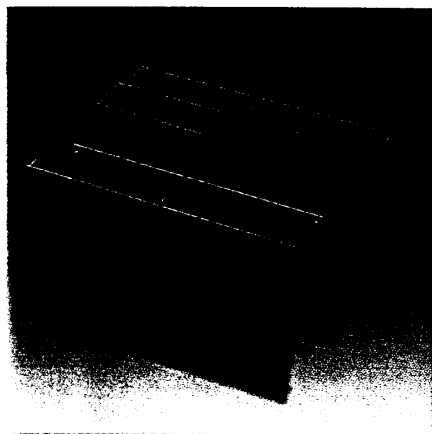

The rail mountable component housing UEG-EU has been specially designed to receive European format cards. The printed circuit board is directly fixed in the housing middle section and the housing closed with two side elements. The positions of the fixing holes on the printed circuit board are the same as for fixing high position plug connectors onto the printed circuit board – so see DIN 41612/part 1. In the middle section break-outs can be punched for the connection elements, whereby both high position plug connectors as well as electronic printed circuit terminal blocks can be used.

For technical data and printed circuit board dimensions see page 27.

Type of moldings

Material = Polyamide 6, see catalog page 12
Color: green

Marking and mounting material see catalog page 10

Maximum component height on the printed circuit board with 1 basic element

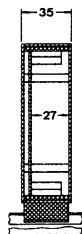

UEG-EU Component housing for European format cards

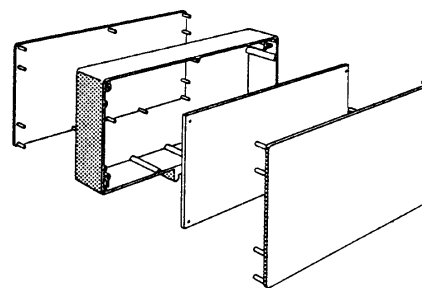
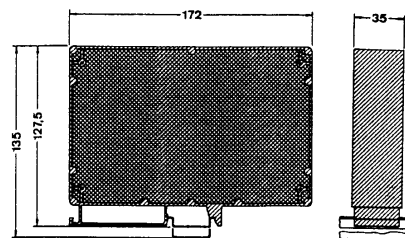

Description

Electronic component housing, comprising:
 basic element with snap foot, for fitting on rail, 32 mm (1.260) wide.

Side element, two pieces, for covering the basic element on both sides,
 1.5 mm (.059) thick

Connection pin, for engaging several basic elements to form one unit;
 12 necessary per element, brass

Type	Order No.	Pcs. Pkt.
UEG-EU-BE	29 56 81 9	5
UEG-EU-SE	29 56 82 2	5
UEG-EU-VS	50 28 88 3	100

mm to inch
27 = (1.063)
35 = (1.378)
127.5 = (5.020)
135 = (5.315)
172 = (6.772)

Printed Circuit Board Layouts for the Electronic Component Housings UEG, UEGM, UEGM-MSTB, UEG-EU in a 1:1 Scale

Printed Circuit Board for Component Housings with Screw Connection

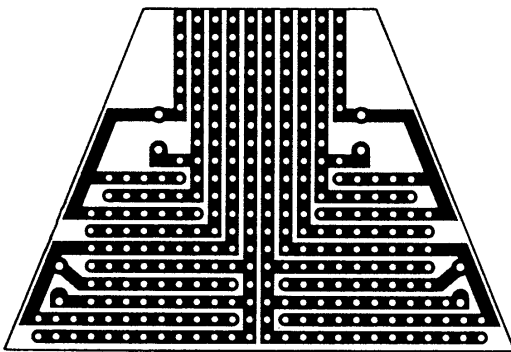
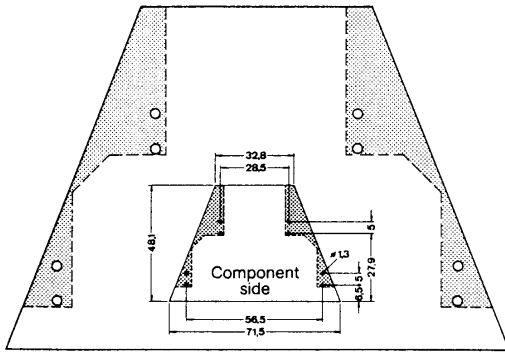

Printed Circuit Board P1-UEG

Printed Circuit Board for Component Housings with Tab Connection

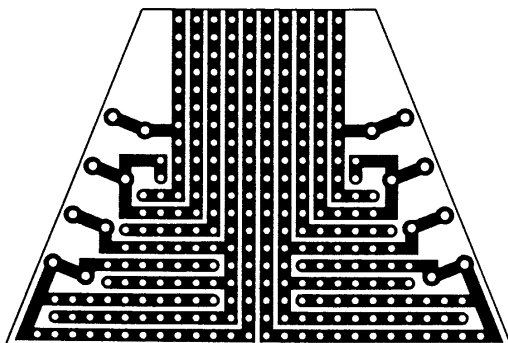
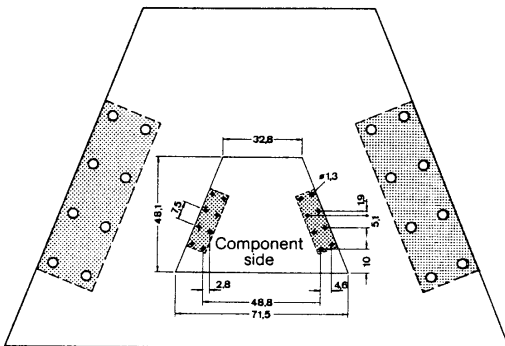

Printed Circuit Board P1-UEG-FS/FS

Printed Circuit Board for Component Housings with Screw Connection

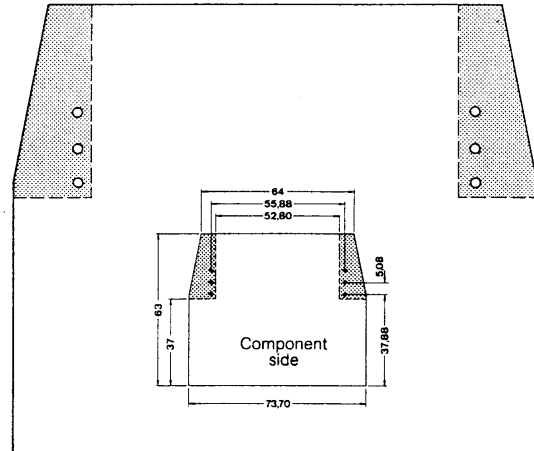

Printed Circuit Board for Component Housings with Tab Connection

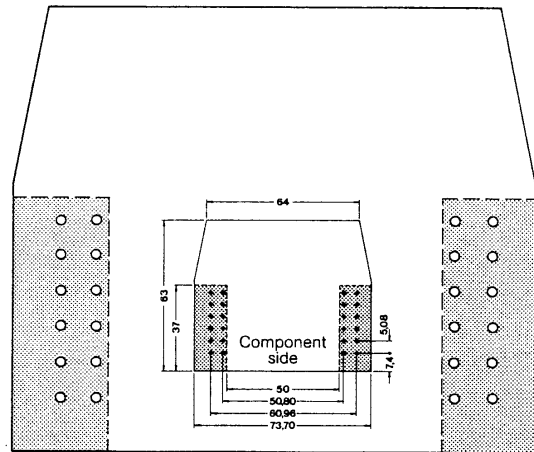

Printed Circuit Board P1-UEGM for Screw and Tab Connection

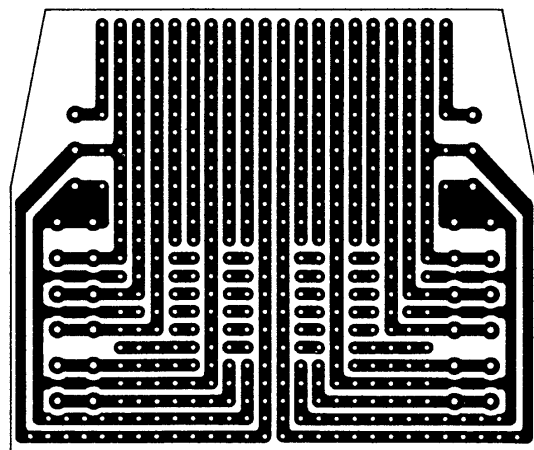

Technical data for the printed circuit board

- Basic material: epoxy glass filament fabric
- 1.5 mm (.059) thick as per DIN 40802
- Copper plating: 70 µm
- Conductor path width: 2 mm (.0790)
- Air and creepage distance: 125 V AC as per VDE 0110/Gr. C VDE 0160
- Holes: 1.3 mm (.051) dia. for the solder pins of the screw and tab connections
- 0.9 mm (.035) dia. for the components as per DIN 40801 page 2

Component Housing UEGM-MSTB

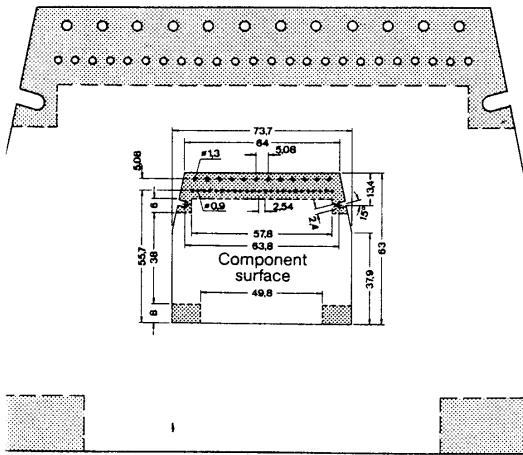

mm to inch	
0.9	= (.035)
1.3	= (.051)
1.9	= (.075)
2.4	= (.094)
2.54	= (.100)
2.76	= (.109)
2.8	= (.110)
4.6	= (.181)
5	= (.197)
5.05	= (.199)
5.08	= (.200)
5.1	= (.201)
6	= (.236)
6.5	= (.256)
7.4	= (.291)
7.5	= (.295)
8	= (.315)
10	= (.394)
13.4	= (.527)
27.9	= (1.098)
28.5	= (1.122)
32.8	= (1.291)
37	= (1.457)
37.88	= (1.491)
37.9	= (1.492)
38	= (1.496)
48.1	= (1.894)
48.8	= (1.912)
49.8	= (1.961)
50	= (1.968)
50.8	= (2.000)
52.8	= (2.079)
55.7	= (2.193)
55.88	= (2.200)
56.5	= (2.224)
57.8	= (2.275)
60.96	= (2.400)
63	= (2.480)
63.8	= (2.512)
64	= (2.520)
71.5	= (2.815)
73.7	= (2.901)
100	= (3.937)
160	= (6.299)

Technical data for the printed circuit board

Basic material: epoxy glass filament fabric
 1.5 mm (.059) thick as per DIN 40802
 Copper plating: 70 µm
 Holes: 1.3 mm (.051) dia. for the solder pins of the COMBICON header
 0.9 mm dia. for the components as per DIN 40801 page 2

Component Housing UEG-EU

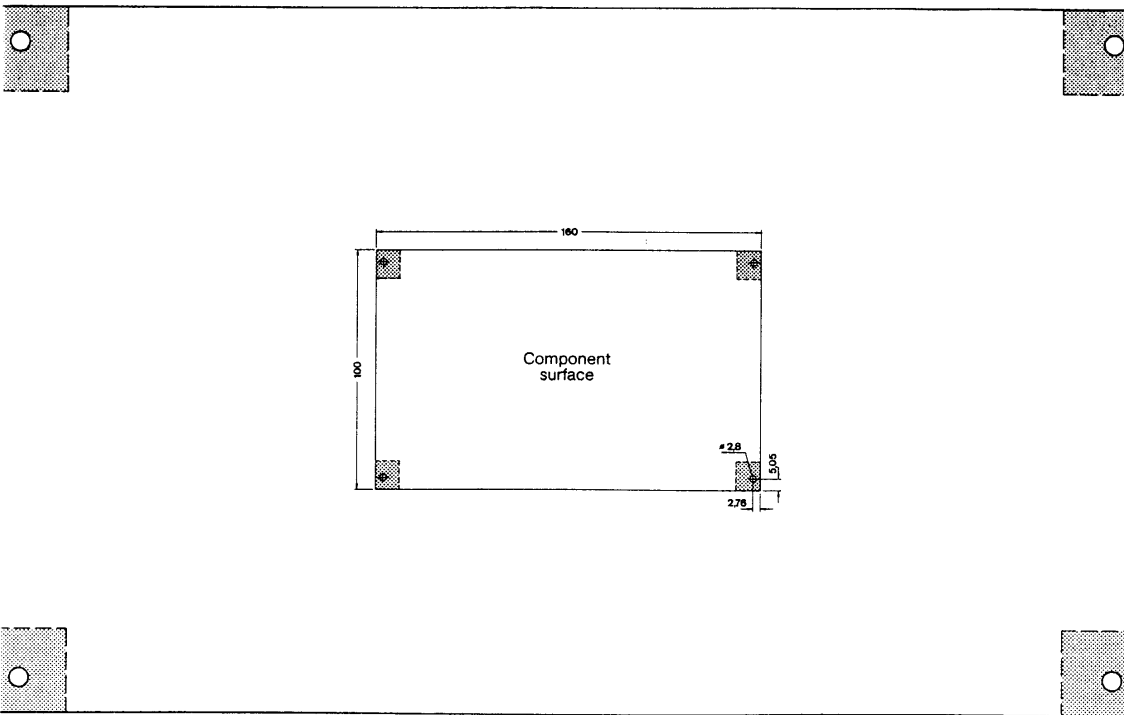

Technical data for the printed circuit board

Basic material: epoxy glass filament fabric
 1.5 mm (.059) thick as per DIN 40802
 Copper plating: 70 µm
 Holes: 1.3 mm (.051) dia. for the solder pins of the screw and tab connections.
 0.9 mm (.035) dia. for the components as per DIN 40801 page 2

Compact Custom Circuit Modules UMK



UMK

Type of moldings

Material = Polyamide 6.6, see catalog page 12
Color: green

Marking and mounting material see catalog page 10

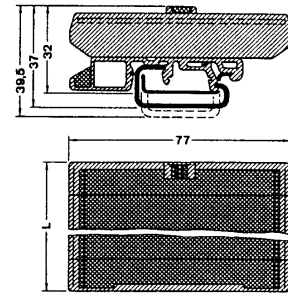

mm to inch
 32 = (1.260)
 37 = (1.457)
 39.5 = (1.555)
 77 = (3.031)

The compact custom circuit module UMK is used where simple adaption and interconnection functions as well as comprehensive electronic circuits require individual rail mountable installation. They are comprised of various single elements with varying dimensions and functions. Depending upon the desired module size and the required space requirement, the various individual elements are linked together to form a module. The PC board base modules UMK are available in a 22.5 – 33.75 – 45 etc.

Two side elements each 11.25 mm wide produce – when engaged – the smallest module of 22.5x77 mm. Due to the adding possibility of the various base elements of 22.5 – 22.5 or 45 mm width the individually required module dimensions are created. Depending upon the module size one or several foot elements are to be provided.









Advantages:

Fast assembly due to the plug in modular principle. The tight engagement of the individual elements ensures a high connection strength.

Due to the universal foot the module adapts on commercially available DIN EN mounting rails.

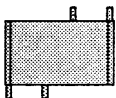
The modules can either be marked using the labeling grooves in the side elements or using the Phoenix module marking 'MB', which snaps in a hole (4 mm dia.) in the printed circuit board.

Wide range of connection possibilities for the external conductor connections due to the large selection of electronic printed circuit boards, the screw, tab connections, the COMBICON plug connector etc. (see catalog page 290).

Description	Type	Order No.	Pcs./Pkt.
Universal module , comprising of: Side element 11.25 mm (.443) wide, with label groove	 UMK-SE 11.25	29 70 00 2	10
Side element , 11.25 mm (.443) wide, without label groove	 UMK-SE 11.25-1	29 70 44 2	10
Base element , 11.25 mm (.443) wide	 UMK-BE 11.25	29 71 53 5	10
Base element , 22.5 mm (.886) wide	 UMK-BE 22.5	29 70 02 8	10
Base element , 45 mm (1.772) wide	 UMK-BE 45	29 70 01 5	10
Foot element , for mounting on  or  , slideable between base and side elements	 UMK-FE	29 70 03 1	10

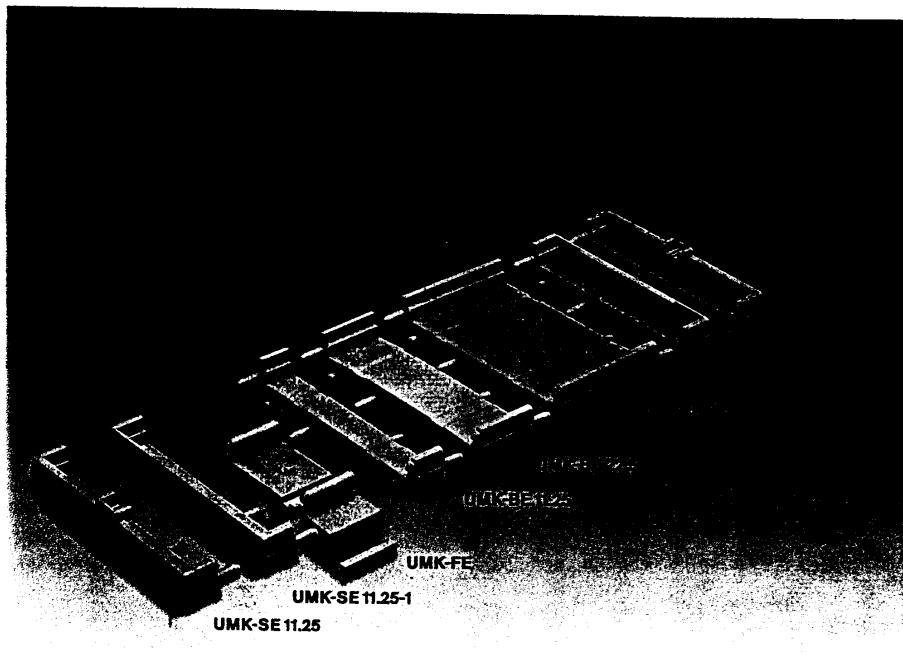

Assembly drawing of the universal module UMK

PCB dimensions [mm]	Module length L [mm]	Side element UMK-SE...	Base element UMK-BE 11.25	Base element UMK-BE 22.5	Base element UMK-BE 45	Foot element UMK-FE
20.00x72x1.5	22.50	2	-	-	-	1
31.25x72x1.5	33.75	2	1	-	-	1
42.50x72x1.5	45.00	2	-	1	-	2
53.75x72x1.5	56.25	2	1	1	-	2
65.00x72x1.5	67.50	2	-	-	1	2
76.25x72x1.5	78.75	2	1	-	1	2
87.50x72x1.5	90.00	2	-	1	1	2
98.75x72x1.5	101.25	2	1	1	1	2
110.00x72x1.5	112.50	2	-	-	2	2
121.25x72x1.5	123.75	2	1	-	2	2
132.50x72x1.5	135.00	2	-	1	2	2
143.75x72x1.5	146.25	2	1	1	2	3
155.00x72x1.5	157.50	2	-	-	3	3
166.25x72x1.5	168.75	2	1	-	3	3
177.50x72x1.5	180.00	2	-	1	3	3

Order example:

UMK module, length 90 mm (3.543), for printed circuit boards 87.5x72x1.5 (3.445x2.835x.059) comprising

- 9 70 00 2 2 side elements UMK-SE 11.25
- 9 70 02 8 1 base element UMK-BE 22.5
- 9 70 01 5 1 base element UMK-BE 45
- 9 70 03 1 2 foot elements UMK-FE

For printed circuit boards see catalog page 290.

Universal Module UM for Custom Circuits

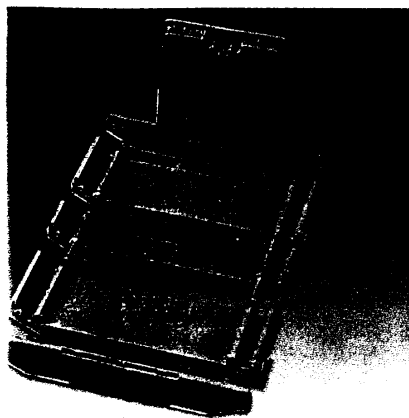

The universal module UM is suitable to accommodate one printed circuit board for mounting in individual electronic circuits, e.g. programmable controls. They comprise individual elements with various dimensions and functions. By arranging individual base elements in a row the printed circuit board face can be multiplied. Metal pins engage the individual base elements to form a sturdy unit. The various base elements are available with and without ribs to support a printed circuit board. Do not locate order points or component fixings in the area of these ribs. Dependent upon the module size one or more base elements are fitted with a snap foot, which easily engage on DIN-EN mounting rails. The side elements form both base element ends arranged in a row and are available in three executions.

The low side element UM-SE, the tall side element UM-SE-A 60 for 60 mm wide U profile covers and the tall side element UM-SE-A 73 for 73 mm wide U profile covers.

The tall side elements are available with and without guide grooves for mechanical mounting of the printed circuit board vertically to the base PCB.

The transparent U profile covers are available in various lengths, which depend on the number of base elements used. They are screw fitted for the tall side elements. Furthermore an engageable transparent hood is available for a base element with snap foot for the lower side elements.

An adaptor rail is available for inserting European format cards. It is pushed laterally over the edge of the base elements thus reducing the width to the European format card dimension. Furthermore, various modules are available for fitting European format cards.

A comprehensive range of electronic printed circuit terminal blocks is available for the conductor connection (see catalog page 290).

U M I
with ribs for mechanical PCB support

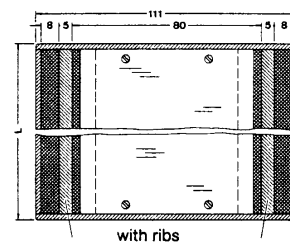
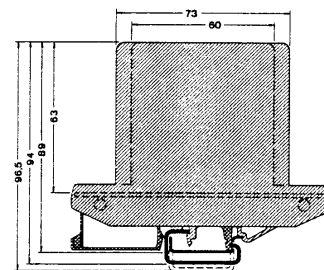

mm to inch
5 = (.197)
8 = (.315)
60 = (2.362)
63 = (2.480)
73 = (2.874)
80 = (3.150)
89 = (3.503)
94 = (3.701)
96.5 = (3.800)
106 = (4.173)
111 = (4.370)

Type of moldings

Krielen = Polyamide 6.6, see catalog page 12
Color: green

U profile cover

Unbreakable PVC
max. temperature: 70° C

Transparent cover

Unbreakable polycarbonate.
Difficult to ignite and self extinguishing,
max. hood temperature: 100° C

Marking and mounting material see catalog page 10

Description

Universal module, individual assembly, selectable consisting of:

- Base element with snap foot**, for mounting on C or T_r
 - a) with ribs, L=35 mm (1.378)
 - b) without ribs, L=35 mm (1.378)
- Base element, without snap foot, necessary for connection of several base elements**
 - a) with ribs, L=35 mm (1.378)
 - b) without ribs, L=35 mm (1.378)
- Base element, without snap foot, necessary for connection of several base elements**
 - a) with ribs, L=16.5 mm (.650)
 - b) without ribs, L=16.5 mm (.650)



a) **UM-BEFE 35**

Order No.

29 55 56 4

Pcs./Pkt.

10



a) **UM-BE 35**

29 55 57 7

10

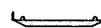

a) **UM-BE 16.5**

29 56 90 3

10

Connection pin, brass, for joining several base elements into one unit, 4 pieces per element

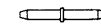

UM-VS

29 55 58 0

50

Side element, low version, for connection on both ends of the base elements UM-BEFE.



UM-SE

29 55 59 3

10

Side element, tall version, for double sided connection of the base elements UM-BEFE

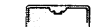

UM-SE-A 60

29 55 61 6

10

for 60 mm wide U profile cover



UM-SE-A 73

29 55 60 3

10

Side element, as above, however, with guide grooves for vertically arranged printed circuit boards



UM-SE-A 60-R

29 56 89 3

10

for 60 mm wide U profile cover



UM-SE-A 73-R

29 56 74 1

10

U profile cover, transparent,

- a) **60 mm (2.362) wide**, screw fitting on side element UM-SE-A 60
 - for 1 base element UM-BE...35 **UM-A/U 60-35** **29 55 65 8** 1
 - 2 base elements UM-BE...35 **UM-A/U 60-70** **29 55 66 1** 1
 - 3 base elements UM-BE...35 **UM-A/U 60-105** **29 55 67 4** 1
 - 4 base elements UM-BE...35 and **UM-A/U 60-156.5** **29 55 55 1** 1
 - 1 base element UM-BE 16.5 for European format card 100x160x1.5 mm
- b) **73 mm (2.874) wide**, screw fitting on side element UM-SE-A 73
 - for 1 base element UM-BE...35 **UM-A/U 73-35** **29 55 62 9** 1
 - 2 base elements UM-BE...35 **UM-A/U 73-70** **29 55 63 2** 1
 - 3 base elements UM-BE...35 **UM-A/U 73-105** **29 55 64 5** 1
 - 4 base elements UM-BE...35 and **UM-A/U 73-156.5** **29 56 16 5** 1
 - 1 base element UM-BE 16.5 for European format card 100x160x1.5 mm

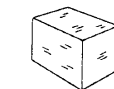
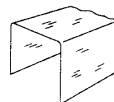

Transparent cover, transparent for one base element, UM-BEFE (with 2 UM-SE) engageable, 60 mm wide, 50 mm high

UM-H

29 55 44 1

1

Adaptor, necessary for European format cards, pushed laterally over the edge of the base elements, reduces width to 100 mm, marking with labeling strip SKS, see catalog page 290, plastic, 156.5 mm (6.555) long



UM-AE

29 56 48 2

1

Universal module, complete accepting a European format card 100x160 mm, without U profile cover

UM-LG 160

29 56 94 5

1

Universal module, as above, however with an additional 60 mm (2.362) wide U profile cover

UM-LG 160/A 60

29 56 95 8

1

Universal module, as above, however with an additional 73 mm (2.874) wide U profile cover

UM-LG 160/A 73

29 56 97 4

1

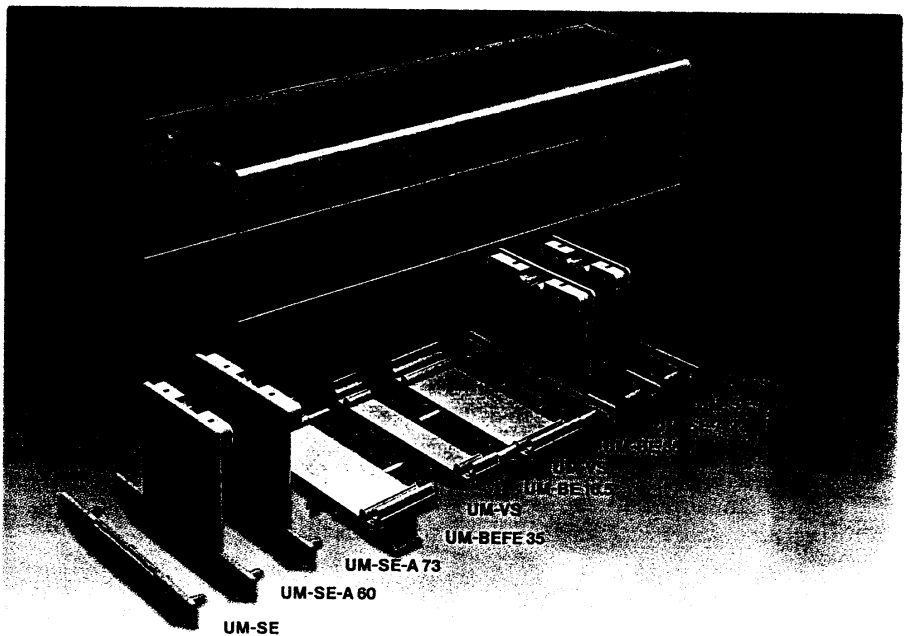
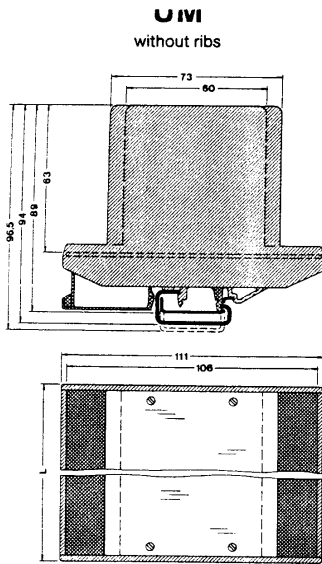

Assembly drawing of UM module base elements with ribs

type	Order No.	Pcs. Pkt.
UM-BEFE 35-1	29 56 66 0	10
UM-BE 35-1	29 56 65 7	10
UM-BE 16.5-1	29 58 05 3	10
UM-VS	29 55 58 0	50
UM-SE-1	29 58 14 7	10
UM-SE-A 60	29 55 61 6	10
UM-SE-A 73	29 55 60 3	10
UM-SE-A 60-R	29 56 89 3	10
UM-SE-A 73-R	29 56 74 1	10
UM-A/U 60-35	29 55 65 8	1
UM-A/U 60-70	29 55 66 1	1
UM-A/U 60-105	29 55 67 4	1
UM-A/U 73-35	29 55 62 9	1
UM-A/U 73-70	29 55 63 2	1
UM-A/U 73-105	29 55 64 5	1
UM-H	29 55 44 1	1

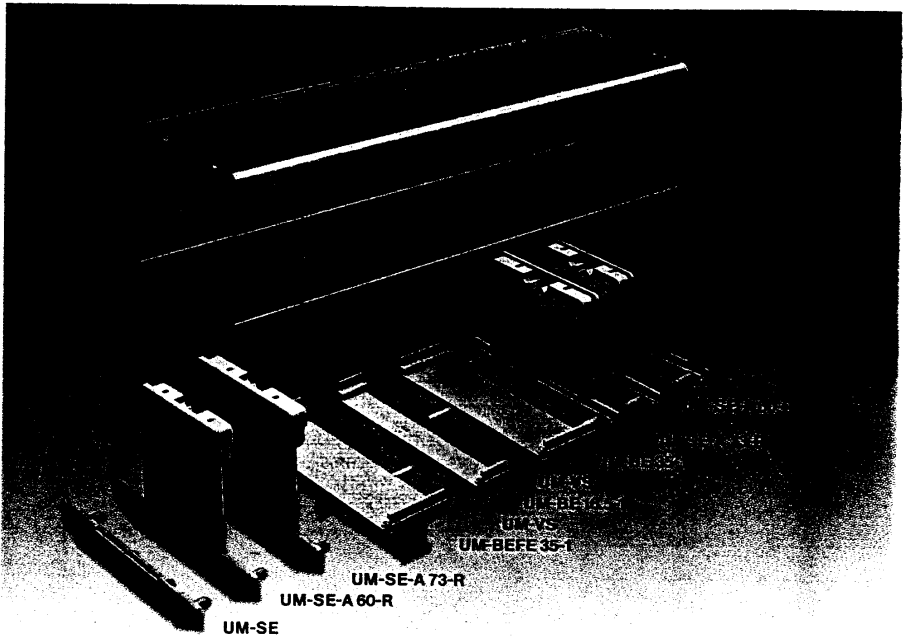

Assembly drawing of UM module base elements without ribs

Dimensions of the PCB* [mm]	Module length L [mm]	Base element UM-BEFE 35 UM-BEFE 35-1	Base element UM-BE 35 UM-BE 35-1	Base element UM-BE 16.5 UM-BE 16.5-1	Base element UM-SE UM-SE A 60 UM-SE-A 73	Length [mm] of th U profile cover UM-A/U 60... UM-A/U 73...
38.5x107.5x1.5	40	1	-	-	2	35
55.0x107.5x1.5	56.5	1	-	1	2	51.5
73.5x107.5x1.5	75	2	-	-	2	70
90.0x107.5x1.5	91.5	2	-	1	2	86.5
108.5x107.5x1.5	110	2	1	-	2	105
125.0x107.5x1.5	126.5	2	1	1	2	121.5
143.5x107.5x1.5	145	2	2	-	2	140
160.0x107.5x1.5	161.5	2	2	-	2	156.5
178.5x107.5x1.5	180	3	2	1	2	175

*When using the adaptor UM-AE the printed circuit board is reduced to 100 mm (3.937).

Order examples:

UM-module, length 40 mm (1.575), for printed circuit board 38.5x107.5x1.5 (1.516x4.232x.059) comprising
 29 55 56 4 1 base element UM-BEFE
 29 55 59 3 2 side elements UM-SE
 29 55 44 1 1 cover UM

UM module, length 110 mm (4.331), for printed circuit board 108.5x107.5x1.5 (4.272x4.232x.059) comprising
 29 55 56 4 2 base elements with snap foot UM-BEFE
 29 55 57 7 1 base element without snap foot UM-BE
 29 55 58 0 8 connection pins UM-VS
 29 55 60 3 2 side elements UM-SE-A 73
 29 55 64 5 1 U profile cover UM-A/U 73-105

UM module 160 mm (6.299), for printed circuit boards in European format 100x160x1.5 (3.937x6.299x.059) comprising
 29 55 56 4 2 base elements with snap foot UM-BEFE 35
 29 55 57 7 2 base elements without snap foot UM-BE 35
 29 56 90 3 1 base element without snap foot UM-BE 16.5
 29 55 58 0 12 connection pins UM-VS
 29 55 61 6 2 side elements UM-SE A 60
 29 55 55 1 1 U profile cover UM-A/U 60-156.5
 29 56 48 2 1 adaptor UM-AE

Information:
 For PCB terminals see catalog page 290.

Mounting Plate EM-MP for Switching Equipment

EM-MP
45 mm wide

EM-MPG 45
45 mm wide

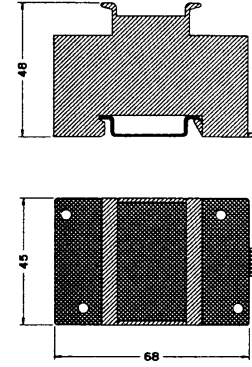
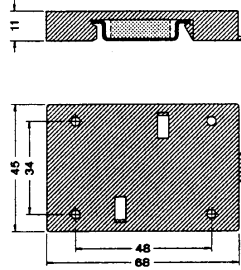
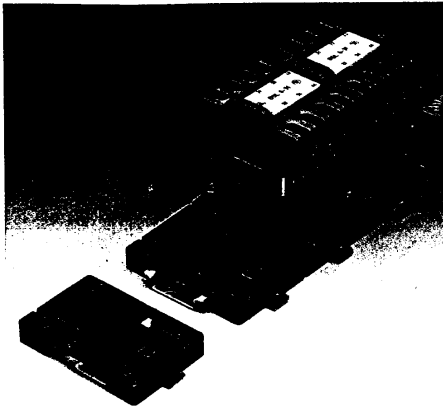

Description	Type	Order No.	Pcs. Pkt.	Type	Order No.	Pcs. Pkt.
Mounting plate, for screw fitting size 0 switching equipment	EM-MP 45	29 44 15 1	5			
Mounting plate, enclosed design, to snap on size 0 switching equipment				EM-MPG 45	29 44 17 7	5
Cover, for the mounting plate EM-MP 45 for fitting protection elements	EM-MP 45 H	29 44 16 4	5			

These rail mounting plates have been specially conceived for size 0 switching equipment. They can accommodate Protection elements or coil protection circuits and motor interference suppression elements. Simple interface functions as linking element between electronic controls and conventional contactor controls can be realized in these units. The following two versions are available:

- Mounting plate EM-MP 45 for screwing onto size 0 switching equipment. The cover, which snaps below the mounting plate, accommodates protection elements for coil protection circuits. The connection lines of the protection elements for the coil connections can be led out of the mounting plate fronts.
- The enclosed mounting plate EM-MPG 45 offering housing character permit size 0 switching equipment to be snapped on. In the mounting plate interior interface functions and protection circuits for coil and motor interference suppression can be fitted. The connection lines between electronic circuit and switching equipment can be led out of the mounting plate front.

Both mounting plates snap on the symmetrical mounting rail in accordance with DIN 50 022.

mm to inch
11=(.433)
34=(1.338)
45=(1.772)
48=(1.890)
68=(2.677)