

HEX BUFFER/LINE DRIVER; 3-STATE

FEATURES

- Non-inverting outputs
- Output capability: bus driver
- I_{CC} category: MSI

GENERAL DESCRIPTION

The 74HC/HCT367 are high-speed Si-gate CMOS devices and are pin compatible with low power Schottky TTL(LSTTL). They are specified in compliance with JEDEC standard no. 7.

The 74HC/HCT367 are hex non-inverting buffer/line drivers with 3-state outputs. The 3-state outputs (nY) are controlled by the output enable inputs (1OE, 2OE).

A HIGH on nOE causes the outputs to assume a high impedance OFF-state.

The "367" is identical to the "368" but has non-inverting outputs.

SYMBOL	PARAMETER	CONDITIONS	TYPICAL		UNIT
			HC	HCT	
t _{PHL} / t _{PLH}	propagation delay nA to nY	C _L = 15 pF V _{CC} = 5 V	8	11	ns
C _I	input capacitance		3.5	3.5	pF
CPD	power dissipation capacitance per buffer	notes 1 and 2	30	32	pF

GND = 0 V; T_{amb} = 25 °C; t_r = t_f = 6 ns

Notes

1. CPD is used to determine the dynamic power dissipation (P_D in μW):

$$P_D = CPD \times V_{CC}^2 \times f_i + \sum (C_L \times V_{CC}^2 \times f_o) \text{ where:}$$

f_i = input frequency in MHz C_L = output load capacitance in pF
 f_o = output frequency in MHz V_{CC} = supply voltage in V
 Σ (C_L × V_{CC}² × f_o) = sum of outputs

2. For HC the condition is V_I = GND to V_{CC}
 For HCT the condition is V_I = GND to V_{CC} - 1.5 V

PACKAGE OUTLINES

16-lead DIL; plastic (SOT38Z).

16-lead mini-pack; plastic (SO16; SOT109A).

PIN DESCRIPTION

PIN NO.	SYMBOL	NAME AND FUNCTION
1, 15	1OE, 2OE	output enable inputs (active LOW)
2, 4, 6, 10, 12, 14	1A to 6A	data inputs
3, 5, 7, 9, 11, 13	1Y to 6Y	data outputs
8	GND	ground (0 V)
16	V _{CC}	positive supply voltage

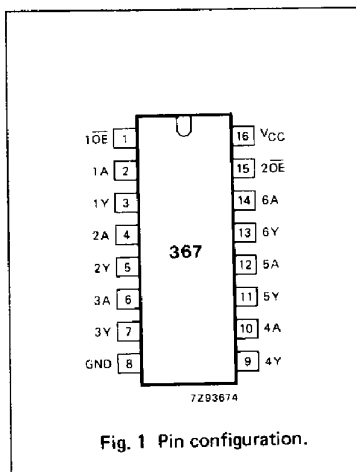

Fig. 1 Pin configuration.

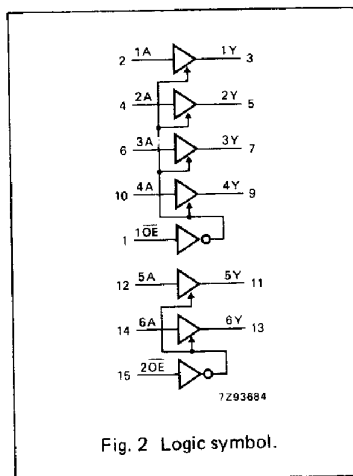

Fig. 2 Logic symbol.

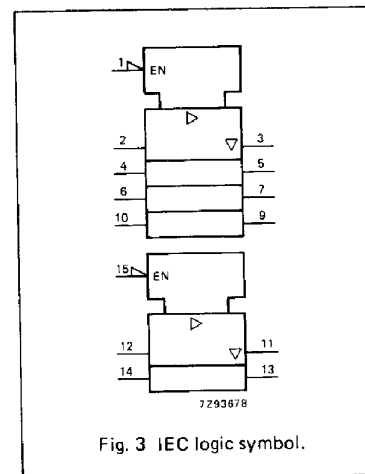

Fig. 3 IEC logic symbol.

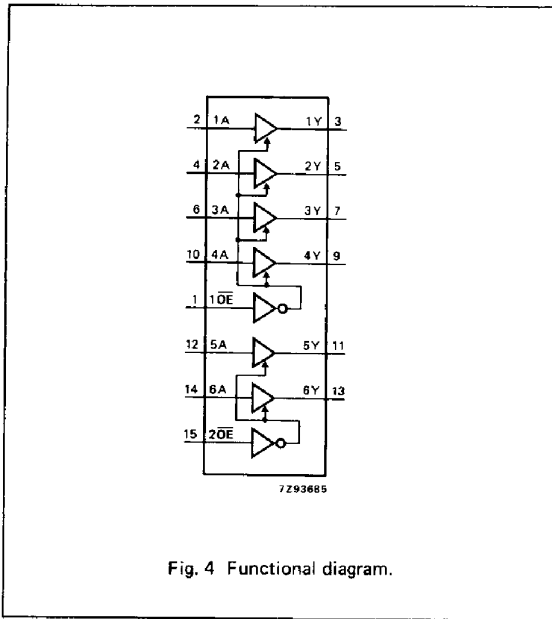

Fig. 4 Functional diagram.

FUNCTION TABLE

INPUTS		OUTPUTS
nOE	nA	nY
L	L	L
L	H	H
H	X	Z

H = HIGH voltage level
L = LOW voltage level
X = don't care
Z = high impedance OFF-state

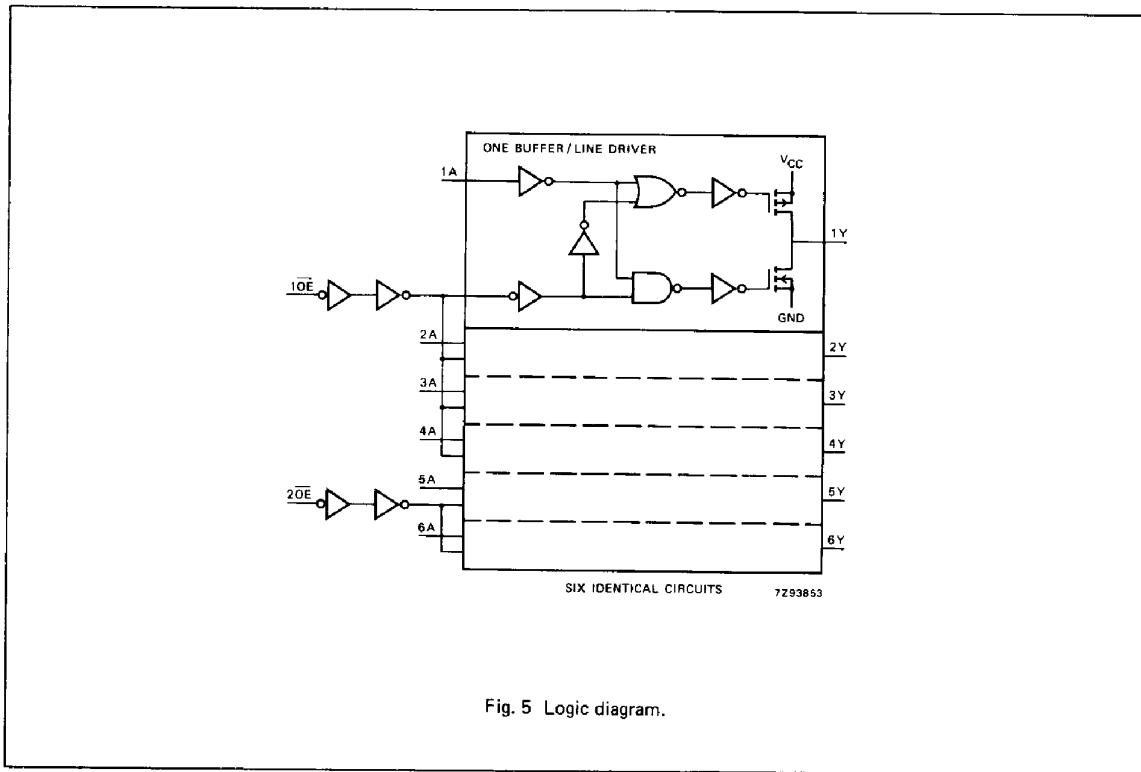

Fig. 5 Logic diagram.

DC CHARACTERISTICS FOR 74HC

For the DC characteristics see chapter "HCMOS family characteristics", section "Family specifications".

Output capability: bus driver

I_{CC} category: MSI

AC CHARACTERISTICS FOR 74HC

GND = 0 V; t_r = t_f = 6 ns; C_L = 50 pF

SYMBOL	PARAMETER	T _{amb} (°C)						UNIT	TEST CONDITIONS		
		74HC							V _{CC} V	WAVEFORMS	
		+25			-40 to +85		-40 to +125				
		min.	typ.	max.	min.	max.	min.				max.
t _{PHL} / t _{PLH}	propagation delay nA to nY		28 10 8	95 19 16		120 24 20		145 29 25	ns	2.0 4.5 6.0	Fig. 6
t _{PZH} / t _{PZL}	3-state output enable time nOE to nY		44 16 13	150 30 26		190 38 33		225 45 38	ns	2.0 4.5 6.0	Fig. 7
t _{PHZ} / t _{PLZ}	3-state output disable time nOE to nY		55 20 16	150 30 26		190 38 33		225 45 38	ns	2.0 4.5 6.0	Fig. 7
t _{THL} / t _{TLLH}	output transition time		14 5 4	60 12 10		75 15 13		90 18 15	ns	2.0 4.5 6.0	Fig. 6

DC CHARACTERISTICS FOR 74HCT

For the DC characteristics see chapter "HCMOS family characteristics", section "Family specifications".

Output capability: bus driver

I_{CC} category: MSI

Note to HCT types

The value of additional quiescent supply current (ΔI_{CC}) for a unit load of 1 is given in the family specifications. To determine ΔI_{CC} per input, multiply this value by the unit load coefficient shown in the table below.

INPUT	UNIT LOAD COEFFICIENT
1OE	1.00
2OE	0.90
nA	1.00

AC CHARACTERISTICS FOR 74HCT

GND = 0 V; $t_r = t_f = 6$ ns; $C_L = 50$ pF

SYMBOL	PARAMETER	T _{amb} (°C)						UNIT	TEST CONDITIONS		
		74HCT							V _{CC} V	WAVEFORMS	
		+25			-40 to +85		-40 to +125				
		min.	typ.	max.	min.	max.	min.				max.
t _{PHL} / t _{PLH}	propagation delay nA to nY		14	25		31		38	ns	4.5	Fig. 6
t _{pZH} / t _{pZL}	3-state output enable time nOE to nY		16	35		44		53	ns	4.5	Fig. 7
t _{pHZ} / t _{PLZ}	3-state output disable time nOE to nY		21	35		44		53	ns	4.5	Fig. 7
t _{THL} / t _{TLH}	output transition time		5	12		15		18	ns	4.5	Fig. 6

AC WAVEFORMS

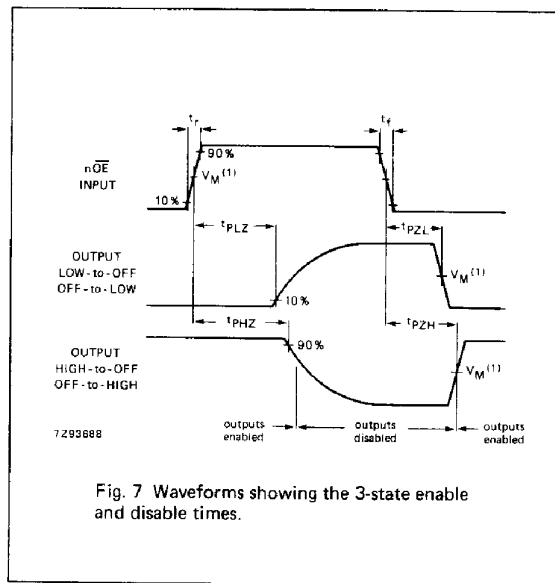
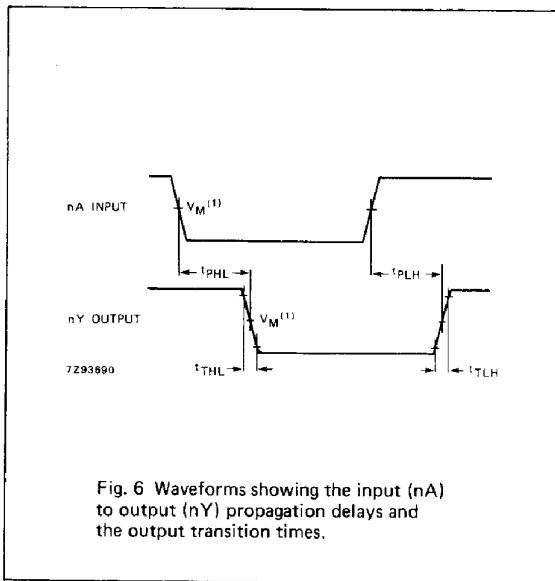

Note to AC waveforms

- (1) HC : $V_M = 50\%$; $V_I = \text{GND to } V_{CC}$.
- HCT: $V_M = 1.3$ V; $V_I = \text{GND to } 3$ V.