

AS5134

Data Sheet

360 Step Programmable High Speed Magnetic Rotary Encoder

1 General Description

The AS5134 is a contactless magnetic rotary encoder for accurate angular measurement over a full turn of 360°.

It is a system-on-chip, combining integrated Hall elements, analog front-end and digital signal processing in a single device.

To measure the angle, only a simple two-pole magnet, rotating over the center of the chip is required.

The absolute angle measurement provides instant indication of the magnet's angular position with a resolution of 8.5 bit = 360 positions per revolution. This digital data is available as a serial bit stream and as a PWM signal.

In addition to the angle information, the strength of the magnetic field is also available as a 6-bit code.

Data transmission can be configured for 1-wire (PWM), 2-wires (DCLK, DIO) or 3-wires (DCLK, DIO, CS).

A software programmable (OTP) zero position simplifies assembly as the zero position of the magnet does not need to be mechanically aligned.

A Power Down Mode together with fast startup and measurement cycles allows for very low average power consumption.

2 Key Features

- 360° contactless angular position encoding
- Two digital 360 step (8.5 bit) absolute outputs: Serial interface and Pulse width modulated (PWM) output
- User programmable zero position and sensitivity
- High speed: upto 25.000 rpm
- Direct measurement of magnetic field strength allows exact determination of vertical magnet distance
- Incremental Outputs ABI Quadrature: 90 ppr, step direction: 180ppr, fixed pulse width 360ppr
- BLDC Outputs UVW, selectable for 1,2,3,4,5,6 pole pairs
- Daisy-Chain mode for cascading of multiple sensors
- 9-bit multiturn counter
- Low power mode with fast startup
- Wide magnetic field input range: 20 – 80 mT
- Wide temperature range: -40°C to +140°C
- Fully automotive qualified to AEC-Q100
- Small Pb-free package: SSOP 20

3 Applications

The AS5134 is suitable for contactless rotary position sensing, rotary switches (human machine interface), AC/DC motor position control and Brushless DC motor position control.

Figure 1. Block Diagram

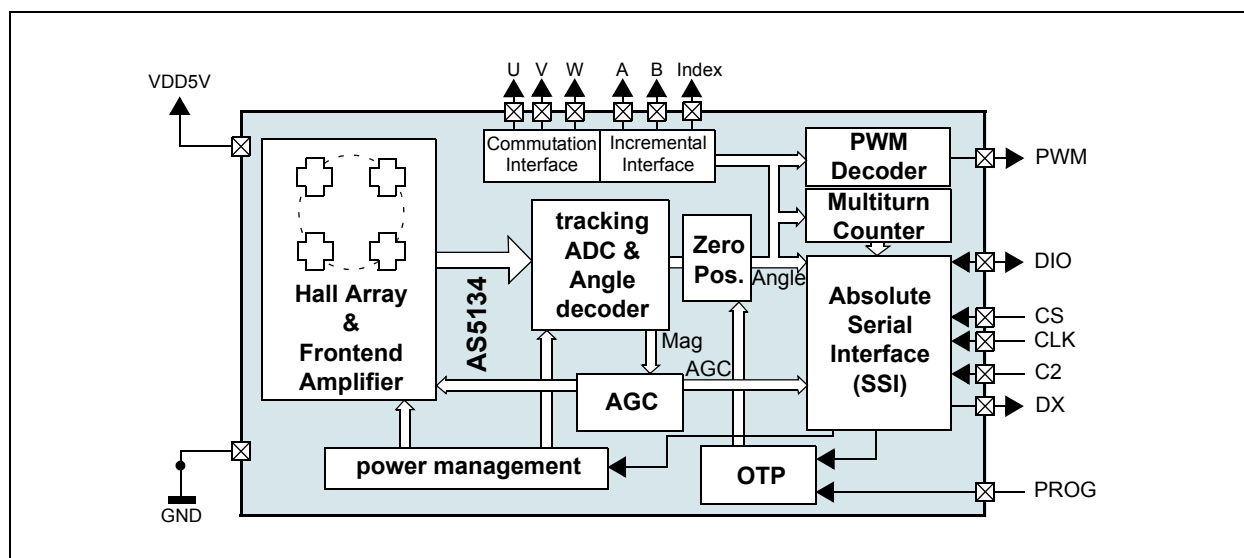

Contents

1	General Description	1
2	Key Features	1
3	Applications	1
4	Pin Assignments	4
	Pin Descriptions	4
5	Absolute Maximum Ratings	5
6	Electrical Characteristics	6
	Timing Characteristics	8
7	Detailed Description	9
	Connecting the AS5134	9
	Serial 3-Wire R/W Connection	10
	Serial 3-Wire Read-only Connection	11
	Serial 2-Wire Connection (R/W Mode)	12
	Serial 2-Wire Differential SSI Connection	12
	1-Wire PWM Connection	13
	Analog Output	14
	Quadrature A/B/Index Output	15
	Brushless DC Motor Commutation Mode	15
	Daisy Chain Mode	16
	Serial Synchronous Interface (SSI)	19
	AS5134 Programming	20
	OTP Programming Connection	20
	Programming Verification	21
	AS5134 Status Indicators	22
	Lock Status Bit	22
	Magnetic Field Strength Indicators	22
	Multi Turn Counter	23
	High Speed Operation	23
	Propagation Delay	24
	ADC Sampling Rate	24
	Chip Internal Lowpass Filtering	24
	Digital Readout Rate	24
	Total Propagation Delay of the AS5134	24
	Low Power Mode	25
	Magnet Diameter and Vertical Distance	26
	The Linear Range	26
	Magnet Thickness	28
	Axial Distance (Airgap)	29
	Angle Error vs. Radial and Axial Misalignment	29
	Accuracy	29
	Mounting the Magnet	30
	Summary	32
8	Application Information	33
	Benefits of AS5134	33
	AS5134 Parameter and Features List	33

9 Package Drawings and Markings	36
Recommended PCB Footprint	37
10 Ordering Information.....	38

4 Pin Assignments

Figure 2. Pin Assignments (Top View)

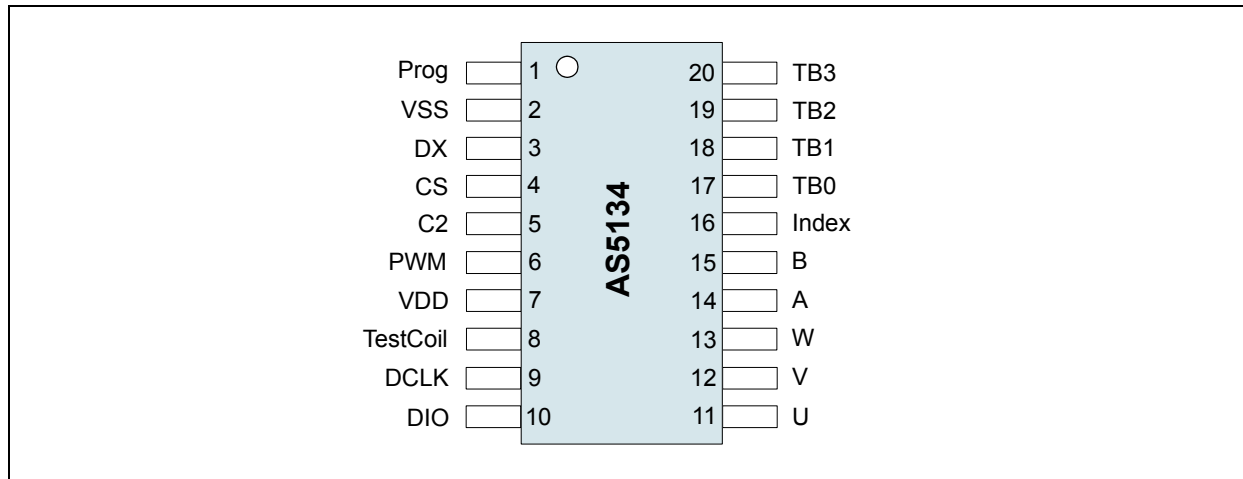

Pin Descriptions

Table 1. Pin Descriptions

Pin Name	Pin Number	Description
Prog	1	Programming voltage input, must be left open in normal operation. Maximum load = 20pF (except during programming)
VSS	2	Supply ground
DX	3	Chip select output for 2-wire mode and Daisy Chain cascading
CS	4	Chip select input for 3-wire mode
C2	5	Select between 2-wire (C2 → VDD) and 3-wire (C2 → VSS) mode
PWM	6	PWM output
VDD	7	Positive supply voltage (double bond to VDD_A and VDD_D)
Test Coil	8	Test pin
DDCLK	9	Clock input for serial interface
DIO	10	Data I/O for serial interface
U	11	Commutation output
V	12	Commutation output
W	13	Commutation output
A	14	Incremental output
B	15	Incremental output
Index	16	Incremental output
TB0	17	Test pin
TB1	18	Test pin
TB2	19	Test pin
TB3	20	Test pin

5 Absolute Maximum Ratings

Stresses beyond those listed in [Table 2](#) may cause permanent damage to the device. These are stress ratings only, and functional operation of the device at these or any other conditions beyond those indicated in [Electrical Characteristics on page 6](#) is not implied. Exposure to absolute maximum rating conditions for extended periods may affect device reliability.

Table 2. Absolute Maximum Ratings

Parameter	Min	Max	Units	Comments
Supply voltage	-0.3	7	V	Except during OTP programming
Input Pin Voltage	VSS-0.5	VDD	V	
Input Current (latch up immunity)	-100	100	mA	Norm: EIA/JESD78 ClassII Level A
ESD	±2		kV	Norm: JESD22-A114E
Package Thermal Resistance SL		145	°C/W	Still Air / Single Layer
Package Thermal Resistance ML		90	°C/W	Still Air / Multi Layer
Storage Temperature	-55	140	°C	
Soldering conditions, Body temperature (Pb-free package)		260	°C	T=20 to 40s, Norm: IPC/JEDEC J-Std-020C. Lead finish 100%Sn "matte tin"
Humidity non-condensing	5	85	%	

6 Electrical Characteristics

T_{AMB} = -40 to 140°C, VDD5V = 4.5-5.5V, all voltages referenced to V_{SS}, unless otherwise noted.

Table 3. Electrical Characteristics

Symbol	Parameter	Conditions	Min	Typ	Max	Units
V _{DD}	Positive Supply Voltage		4.5		+5.5	V
I _{DD}	Operating Current	No load on outputs. Supply current can be reduced by using stronger magnets.			15	mA
I _{off}	Power down current	Low Power Mode		70	120	µA
T _J	Junction Temperature				170	°C
System Parameters						
N	Resolution			8.5		Bit
				1		Deg
T _{PwrUp}	Power Up Time	Startup from zero			≤4100	µs
		Startup from Low Power mode			≤500	
t _s	Tracking rate	Step rate of tracking ADC; 1 step = 1°	3.0	4	5.2	µs/step
INL _{cm}	Accuracy	Centered Magnet	-2		2	Deg
		Within horizontal displacement radius (4.4)	-3		3	Deg
t _{delay}	Propagation delay			17	22	µs
TN	Transition noise	Peak-Peak			1.41	Deg
Magnet Specifications						
MD	Magnet diameter	Diametrically magnetized		6		mm
MT	Magnet thickness			2.5		mm
B _i	Magnetic Input Range	Package surface	20		80	mT
V _i	Magnet rotation speed	to maintain locked state			25.000	rpm
	Hall Array radius			1		mm
	Vertical distance of magnet		0.5	1	1.8	mm
	Horizontal magnet displacement radius	Max X-Y Offset between defined IC Package center and magnet axis			0.25	mm
		Max X-Y Offset between chip center and magnet axis			0.48	
PWM Output						
N _{PWM}	PWM resolution			8.5		Bit
		1 Step = 1°		2		µs/step
PW _{MIN}	PWM pulse width	Angle = 0° (00 _H)		16		µs
PW _{MAX}	PWM pulse width	Angle = 360° (FF _H)		734		µs
t _{PWM}	PWM period			750		µs
f _{PWM}	PWM frequency	=1 / PWM period		1.33		kHz
Programming Parameters						
V _{PROG}	Programming Voltage	Static voltage at pin Prog	8.0		8.5	V
I _{PROG}	Programming Current				100	mA

Table 3. Electrical Characteristics (Continued)

Symbol	Parameter	Conditions	Min	Typ	Max	Units
Tamb _{PROG}	Programming ambient temperature	During programming	0		85	°C
t _{PROG}	Programming time	Timing is internally generated	2		4	µs
V _{R,prog}	Analog readback voltage	During analog readback mode at pin Prog			0.5	V
V _{R,unprog}			2.2		3.5	
Hall Element Sensitivity Options						
sens	Hall Element sensitivity setting	sens = 00 (default; high sensitivity)		1.65		X
		sens = 01		1.88		
		sens = 10		2.11		
		sens = 11 (low sensitivity)		2.35		
DC Characteristics of Digital Inputs and Outputs						
CMOS Inputs: DDCLK, CS, DIO, C2						
V _{IH}	High level input voltage		0.7*V _{DD}			V
V _{IL}	Low level input voltage				0.3*V _{DD}	V
I _{LEAK}	Input leakage current				1	µA
CMOS Outputs: DIO, PWM, DX						
V _{OH}	High level output voltage	Source current < 4mA	V _{DD} -0.5			V
V _{OL}	Low level output voltage	Sink current < 4mA			V _{SS} +0.4	V
CL	Capacitive load				35	pF
CMOS Tristate Output: DIO						
I _{OZ}	Tristate leakage current	CS = low			1	µA

Timing Characteristics

Table 4. Timing Characteristics

Symbol	Parameter	Conditions	Min	Typ	Max	Units
2-/3-Wire Data Transmission						
3-Wire Interface						
f_{DCLK}	Clock Frequency	Normal operation	No limit	5	6	MHz
$f_{\text{DCLK,P}}$	Clock Frequency	During OTP programming	200		650	kHz
2-Wire Interface						
f_{DCLK}	Clock Frequency	Normal operation	0.1	5	6	MHz
$f_{\text{DCLK,P}}$	Clock Frequency	During OTP programming	200		500	kHz
General Data Transmission						
t_0	Rising DCLK to CS		15		-	ns
t_1	Chip select to positive edge of DCLK		15		-	ns
t_2	Chip select to drive bus externally		-		-	ns
t_3	Setup time command bit, Data valid to positive edge of DCLK		30		-	ns
t_4	Hold time command bit, Data valid after positive edge of DCLK		30			ns
t_5	Float time, Positive edge of DCLK for last command bit to bus float		30		DCLK/2	ns
t_6	Bus driving time, Positive edge of DCLK for last command bit to bus drive		DCLK/2 +0		DCLK/2 +30	ns
t_7	Setup time data bit, Data valid to positive edge of DCLK		DCLK/2 +0		DCLK/2 +30	ns
t_8	Hold time data bit, Data valid after positive edge of DCLK		DCLK/2 +0		DCLK/2 +30	ns
t_9	Hold time chip select, Positive edge DCLK to negative edge of chip select		30			ns
t_{10}	Bus floating time, Negative edge of chip select to float bus		0		30	ns
t_{TO}	Timeout period in 2-wire mode (from rising edge of DCLK)		20		24	μs

7 Detailed Description

Figure 3. Typical Arrangement of AS5134 and Magnet

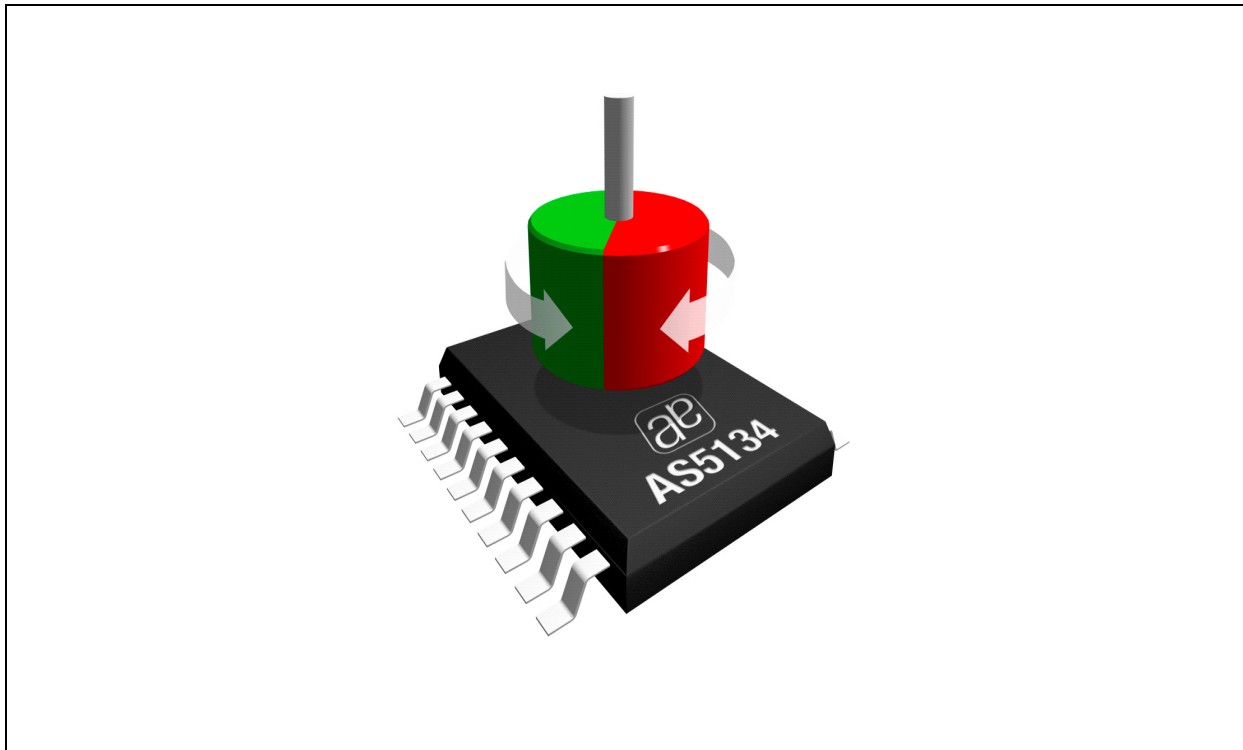

Connecting the AS5134

The AS5134 can be connected to an external controller in several ways as listed below:

- Serial 3-wire R/W connection
- Serial 3-wire Read-only connection
- Serial 2-Wire connection (R/W Mode)
- Serial 2-Wire Differential SSI connection
- 1-Wire PWM connection
- Analog output
- Quadrature A/B/Index output
- Brushless DC Motor Commutation Mode
- Daisy Chain Mode

Serial 3-Wire R/W Connection

In this mode, the AS5134 is connected to the external controller via three signals: Chip Select (CS), Clock (DCLK) inputs and bi-directional DIO (Data In/Out) output. The controller sends commands over the DIO pin at the beginning of each data transmission sequence, such as reading the angle or putting the AS5134 in and out of the reduced power modes.

Figure 4. SSI Read/Write Serial Data Transmission

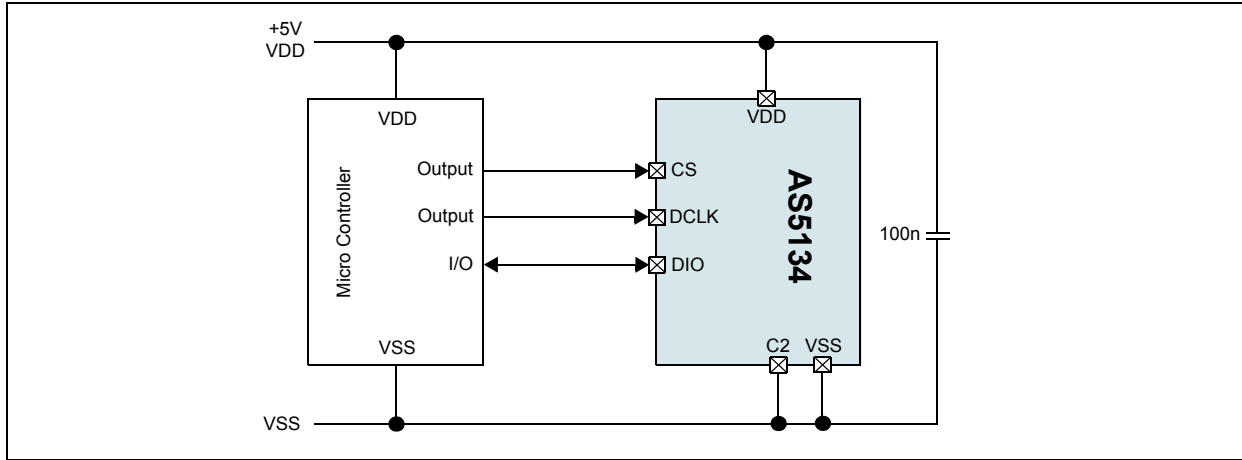

A pull-down resistor (as shown in Figure 5) is not required. C2 is a hardware configuration input. C2 selects 3-wire mode (C2 = low) or 2-wire mode (C2 = high).

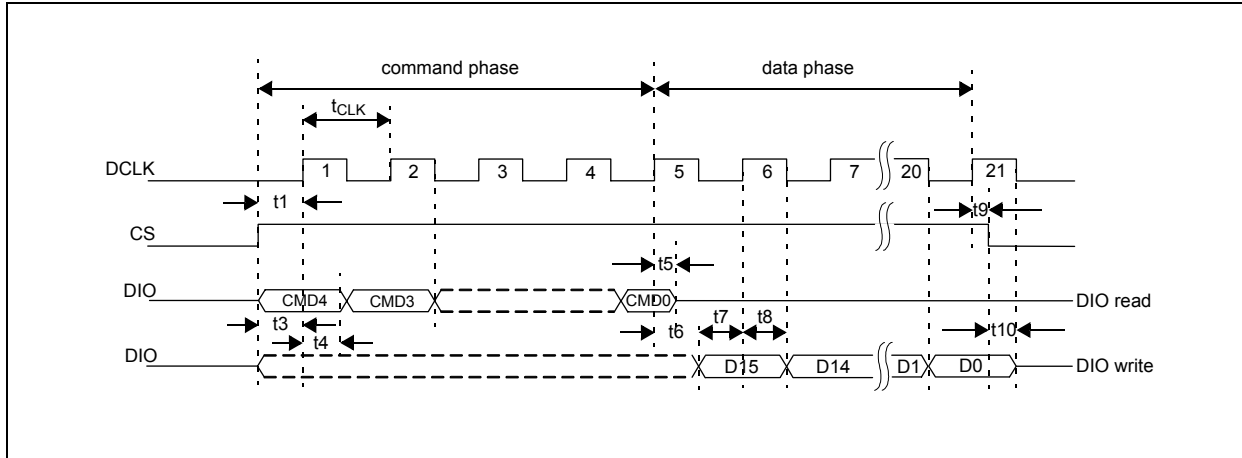

Table 5. Serial Bit Sequence (16bit read/write)

Write Command					Read/Write Data															
C4	C3	C2	C1	C0	D15	D14	D13	D12	D11	D10	D9	D8	D7	D6	D5	D4	D3	D2	D1	D0

Serial 3-Wire Read-only Connection

This simplified connection is possible when the AS5134 is only used to provide the angular data (no power down or OTP access). The Chip Select (CS) and Clock (DCLK) connection is the same as in the R/W mode, but only a digital input pin (not an I/O pin) is required for the DIO connection. As the first 5 bits of the data transmission are command bits sent to the AS5134, both the microcontroller and the AS5134 are configured as digital inputs during this phase. Therefore, a pull-down resistor must be added to make sure that the AS5134 reads “00000” as the first 5 bits, which sets the Read_Angle command.

Note: All further application examples are shown in R/W mode, however read-only mode is also possible unless otherwise noted.

Figure 5. SSI Read-only Serial Data Transmission

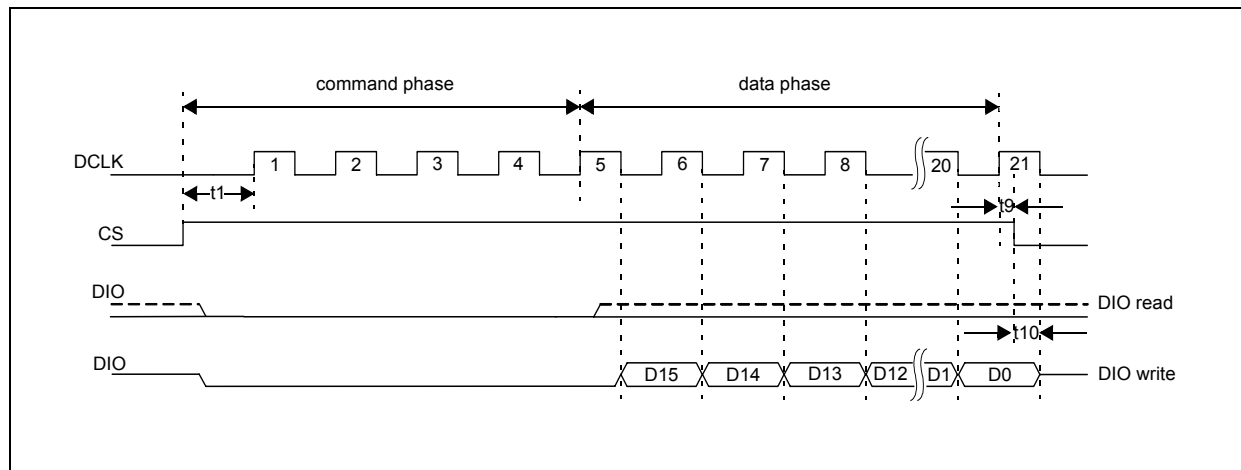
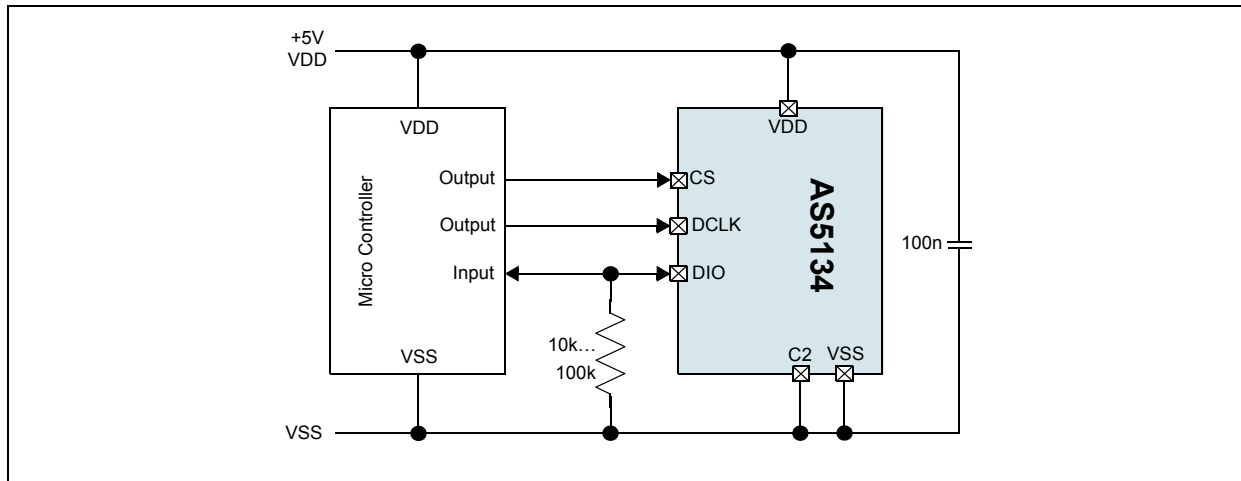

Table 6. 2- or 3-wire Read-only Serial Bit Sequence (21bit read)

Read																				
D20	D19	D18	D17	D16	D15	D14	D13	D12	D11	D10	D9	D8	D7	D6	D5	D4	D3	D2	D1	D0
0	0	0	0	0	lock	AGC					Angle									
						D5	D4	D3	D2	D1	D0	D8	D7	D6	D5	D4	D3	D2	D1	D0

Serial 2-Wire Connection (R/W Mode)

By connecting the configuration input C2 to VDD, the AS5134 is configured to 2-wire data transmission mode. Only Clock (DCLK) and Data (DIO) signals are required. A Chip Select (CS) signal is automatically generated by the DX output, when a time-out of DCLK occurs (typ. 20 μ s).

Note: Read-only mode is also possible in this configuration.

Figure 6. 2-Wire R/W Mode

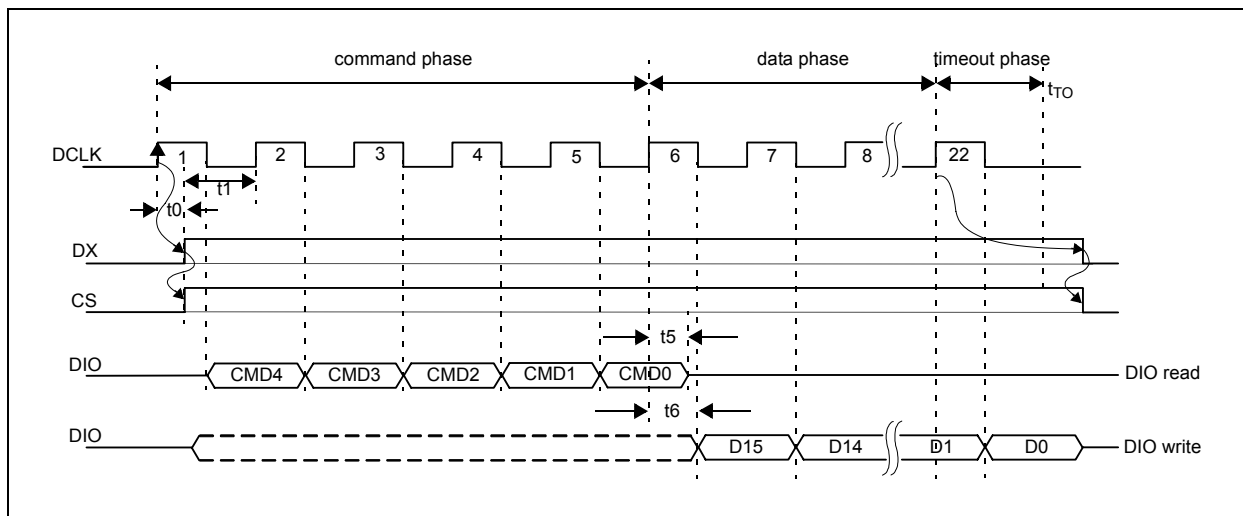
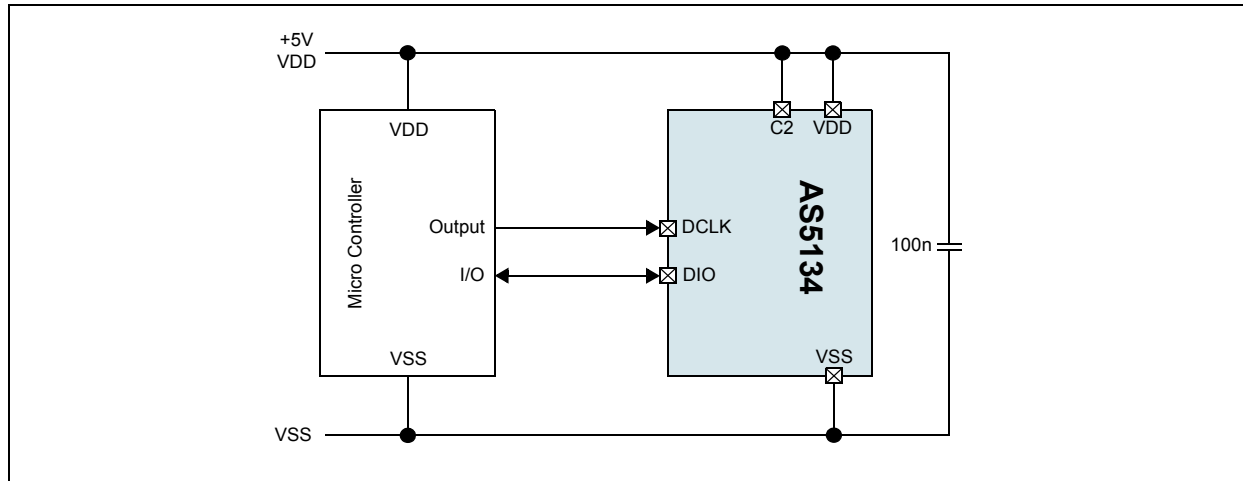

Serial 2-Wire Differential SSI Connection

With the addition of a RS-422 / RS-485 transceiver, a fully differential data transmission, according to the 21-bit SSI interface standard is possible. To be compatible with this standard, the DCLK signal must be inverted. This is done by reversing the Data+ and Data- lines of the transceiver.

Note: This type of transmission is read-only.

Figure 7. 2-Wire SSI Read-only Mode

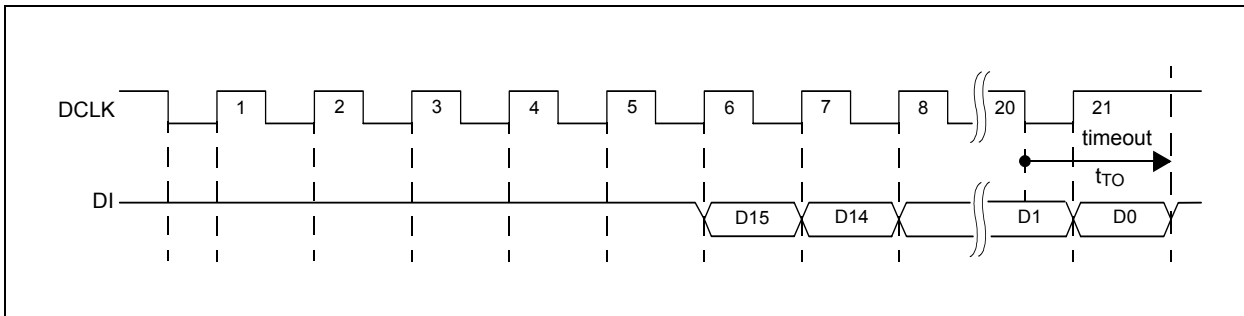
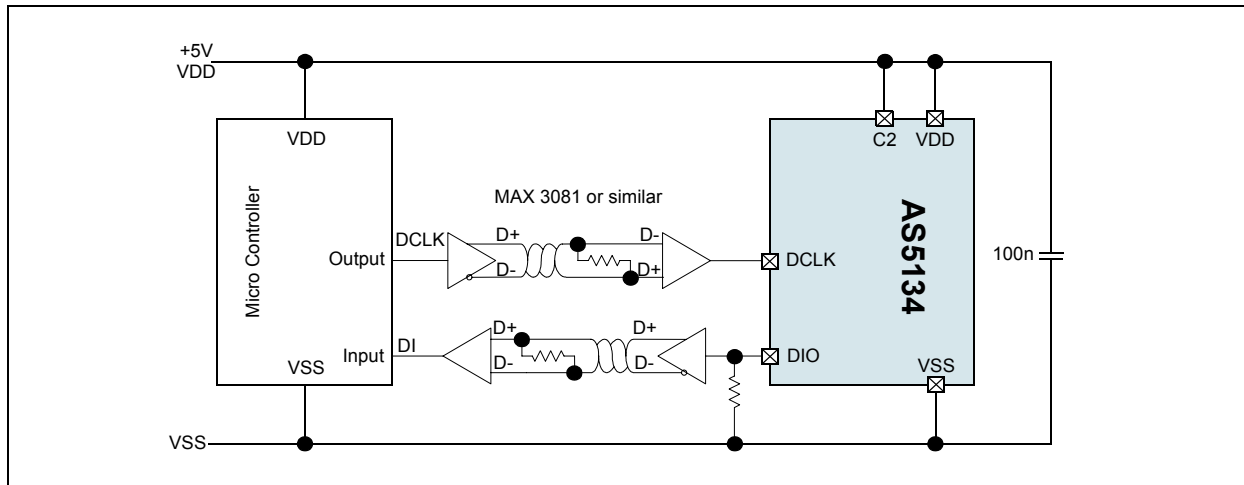

Read																				
D20	D19	D18	D17	D16	D15	D14	D13	D12	D11	D10	D9	D8	D7	D6	D5	D4	D3	D2	D1	D0
0	0	0	0	0	lock	AGC					Angle									
						D5	D4	D3	D2	D1	D0	D8	D7	D6	D5	D4	D3	D2	D1	D0

1-Wire PWM Connection

This configuration uses the least number of wires: only one line (PWM) is used for data, leaving the total number of connection to three, including the supply lines. This type of configuration is especially useful for remote sensors. Ultra Low Power Mode is not possible in this configuration, as there is no bi-directional data transmission. If the AS5134 angular data is invalid, the PWM output will remain at low state. Pins that are not shown may be left open.

Figure 8. Data Transmission with Pulse Width Modulated (PWM) Output

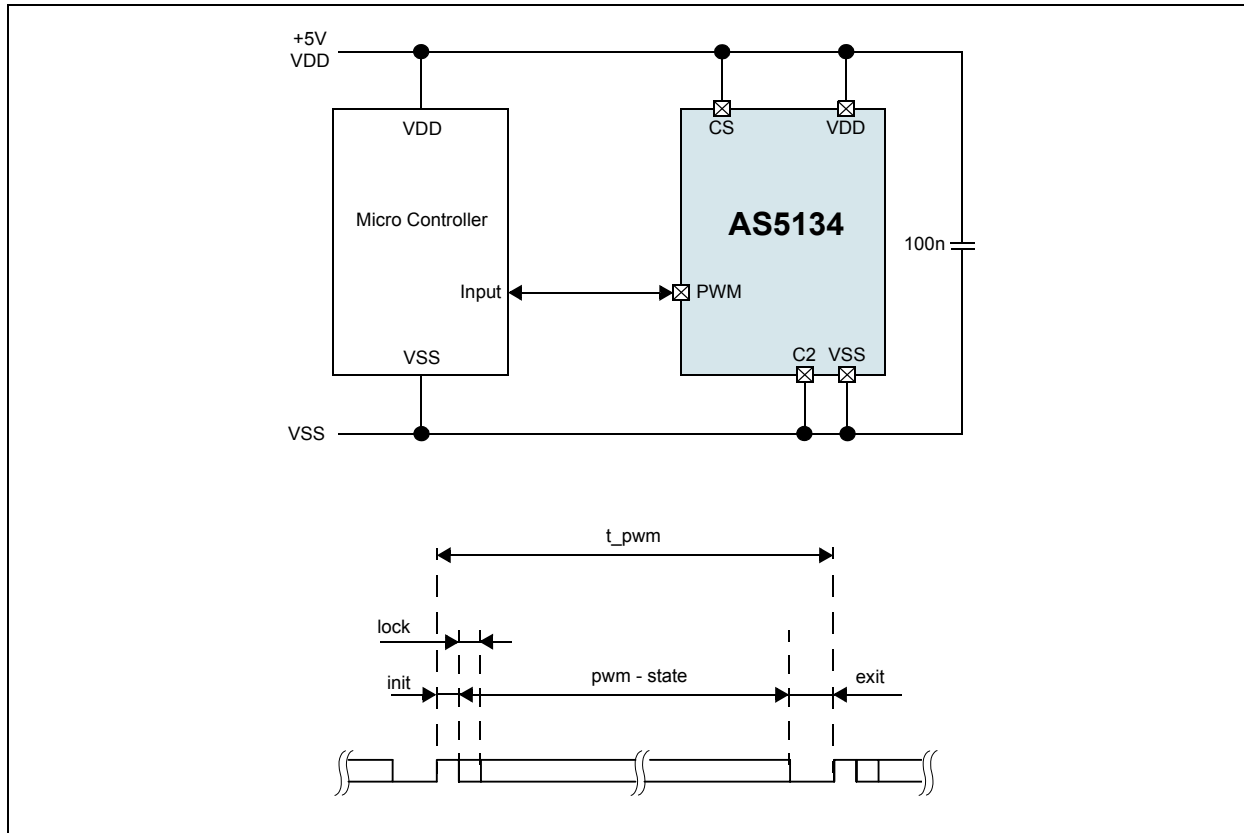

The PWM signal will be generated from the actual stored angle information. The zero-angle corrected value is buffered and fixed until the next PWM-sequence is started. To ease the filtering of the PWM signal, a minimum pulse width is implemented in the protocol.

Analog Output

This configuration is similar to the PWM connection (only three lines including supply are required). With the addition of a lowpass filter at the PWM output, this configuration produces an analog voltage that is proportional to the angle. This filter can be either passive (as shown in Figure 9) or active. The lower the bandwidth of the filter, the less ripple of the analog output can be achieved. If the AS5134 angular data is invalid, the PWM output will remain at low state and thus the analog output will be 0V. Pins that are not shown may be left open.

Figure 9. Data Transmission with Pulse Width Modulated (PWM) Output

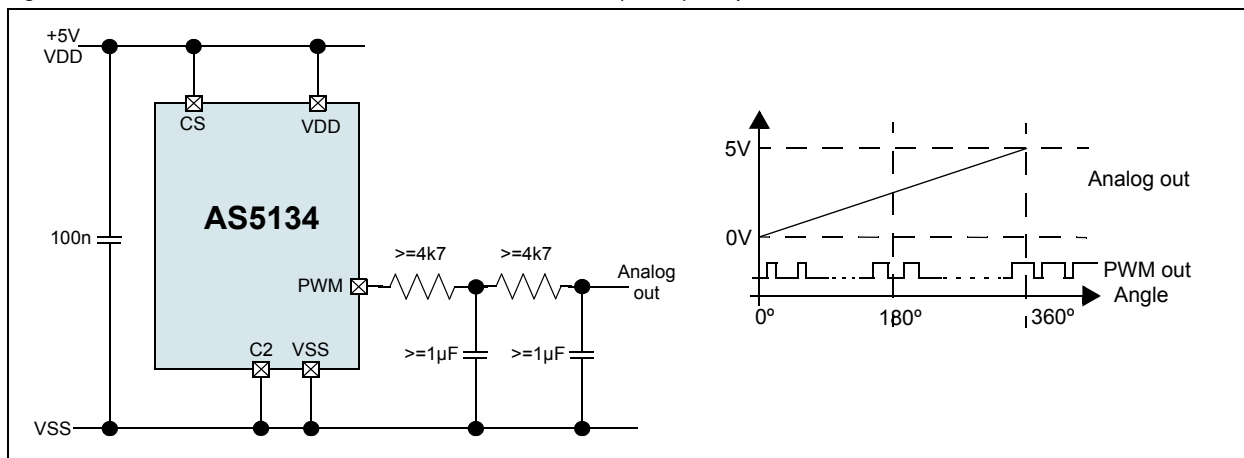

Quadrature A/B/Index Output

The phase shift between channel A and B indicates the direction of the magnet movement. Channel A leads channel B at a clockwise rotation of the magnet (top view) by 90 electrical degrees. Channel B leads channel A at a counter-clockwise rotation.

Figure 10. Incremental Output Modes

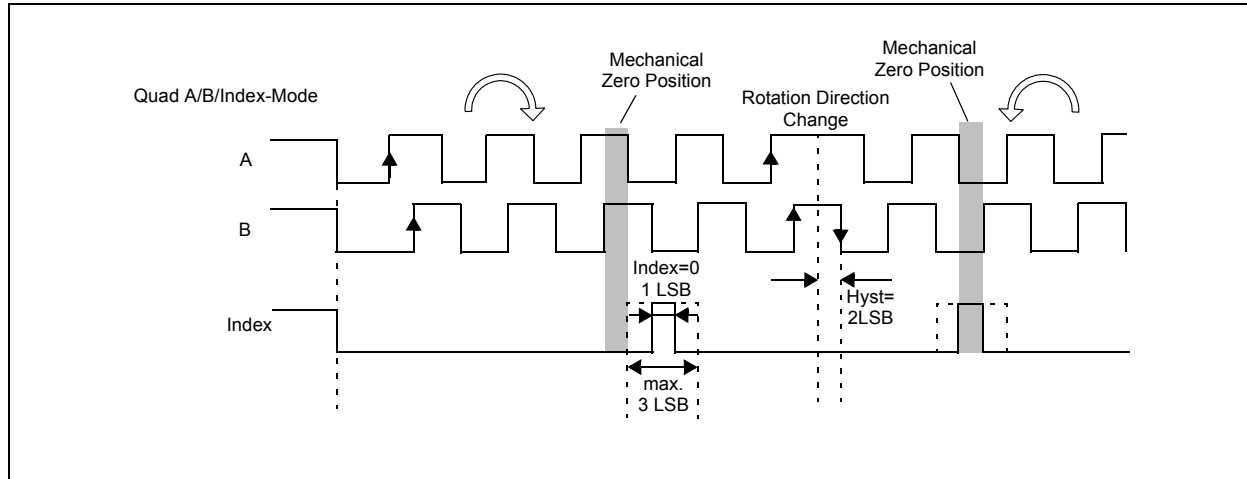

Table 7. Programming Options for the Quadrature Signals A/B/Index

Abi (13:12)		Function: output multiplexer for pin A,B,I
0	0	A → pin A, B → pin B, I(index) → pin I default value)
0	1	step → pin A, direction → pin B, I(index) → pin I
1	0	pulse → pin A, direction → pin B, I(index) → pin I
1	1	off: LO → pin A, LO → pin B, LO → pin I

Brushless DC Motor Commutation Mode

The BLDC signals will be used to control the electrical angle information – according to the amount of pole pairs and the actual mechanical angle position. Refer [Figure](#) for an example of $n_{pole_pairs}=2$. For the programming, refer to [Serial Synchronous Interface \(SSI\) on page 19](#).

Figure 11. Commutation Mode

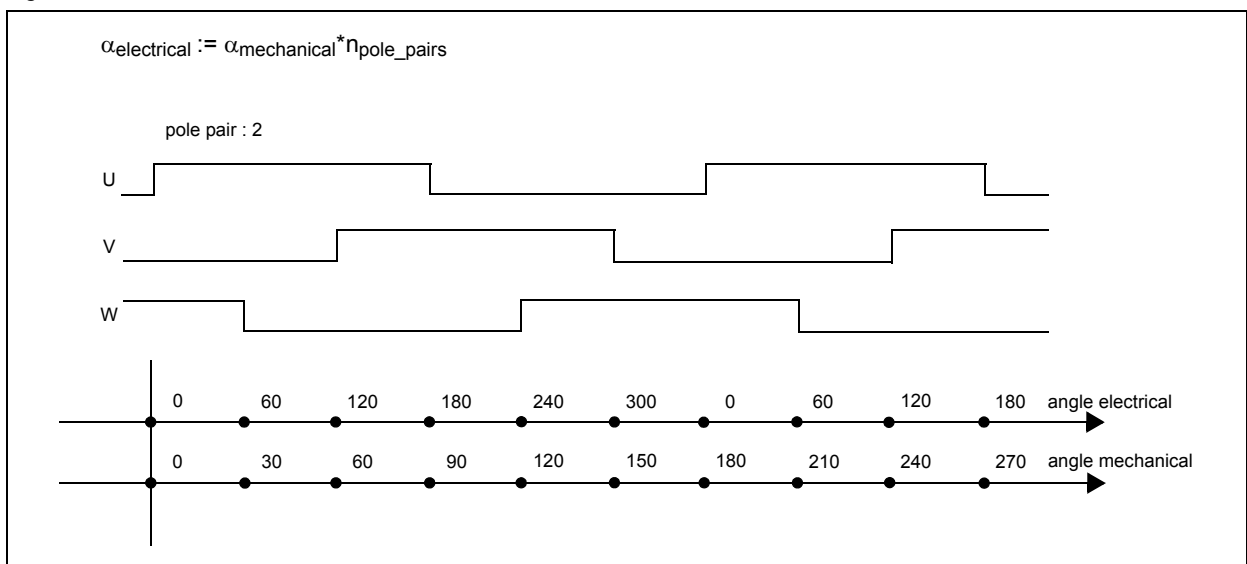

Table 8. Programming Options for the Commutation Signals U/V/W

uvw (11:9)			Function
0	0	0	BLDC Pole Pairs : 1 → electrical angle of 60° := mechanical angle: 60°
0	0	1	BLDC Pole Pairs : 2 → electrical angle of 60° := mechanical angle: 30°
0	1	0	BLDC Pole Pairs : 3 → electrical angle of 60° := mechanical angle: 20°
0	1	1	BLDC Pole Pairs : 4 → electrical angle of 60° := mechanical angle: 15°
1	0	0	BLDC Pole Pairs : 5 → electrical angle of 60° := mechanical angle: 12°
1	0	1	BLDC Pole Pairs : 6 → electrical angle of 60° := mechanical angle: 10°
1	1	1	off → LO pad U,V,W, PWM

Daisy Chain Mode

The angle information from the device and the setup for the device is handled over the digital interface. A special port (Dx) can be used to implement a daisy chain mode. Depending on the configuration, it is possible to implement a two wire or a three wire mode. In the three wire mode, each communication starts with the rising edge of the chip select signal. The Port Dx is used to transfer the chip select information from one device to the next. Refer to [Figure 12](#) and [Figure 13](#). In the two wire interface mode, a timeout logic ensures that the digital interface will be reset if there is no clock source available for a certain time. The synchronization between the internal free running analog clock oscillator and the external used digital clock source for the digital interface is done in a way that the digital clock frequency can vary in a wide range.

Remark: Reset for the digital interface:

3 wire mode → via chip select

2 wire mode → via timeout

Port	Symbol	Function
chip select	CS	Indicates the start of a new access cycle to the device CS = LO → reset of the digital interface.
DCLK	DCLK	Clock source for the communication over the digital interface. The maximum and minimum frequency depends on the mode.
bidirectional data input output	DIO	Command and data information over one single line. The first bit of the command defines a read or write access.
Daisy Chain Port	Dx	This port enables the daisy chain configuration of several devices. Three wire mode: Indicates the end of an interface cycle. Dx can be used as the chip select signal for the next device in the chain. Two wire mode: Will be set with the first falling edge of DCLK and hence, indicates a running clock; it will be cleared at the end of the command sequence or after a timeout phase. Dx can be used as a chip select signal in the two wire mode.

Waveform – Digital Interface @ Three Wire Daisy Chain Mode

Note: Defined if the Pin C2 is set to LO @ all devices

Figure 12. Three Wire Daisy Chain Mode

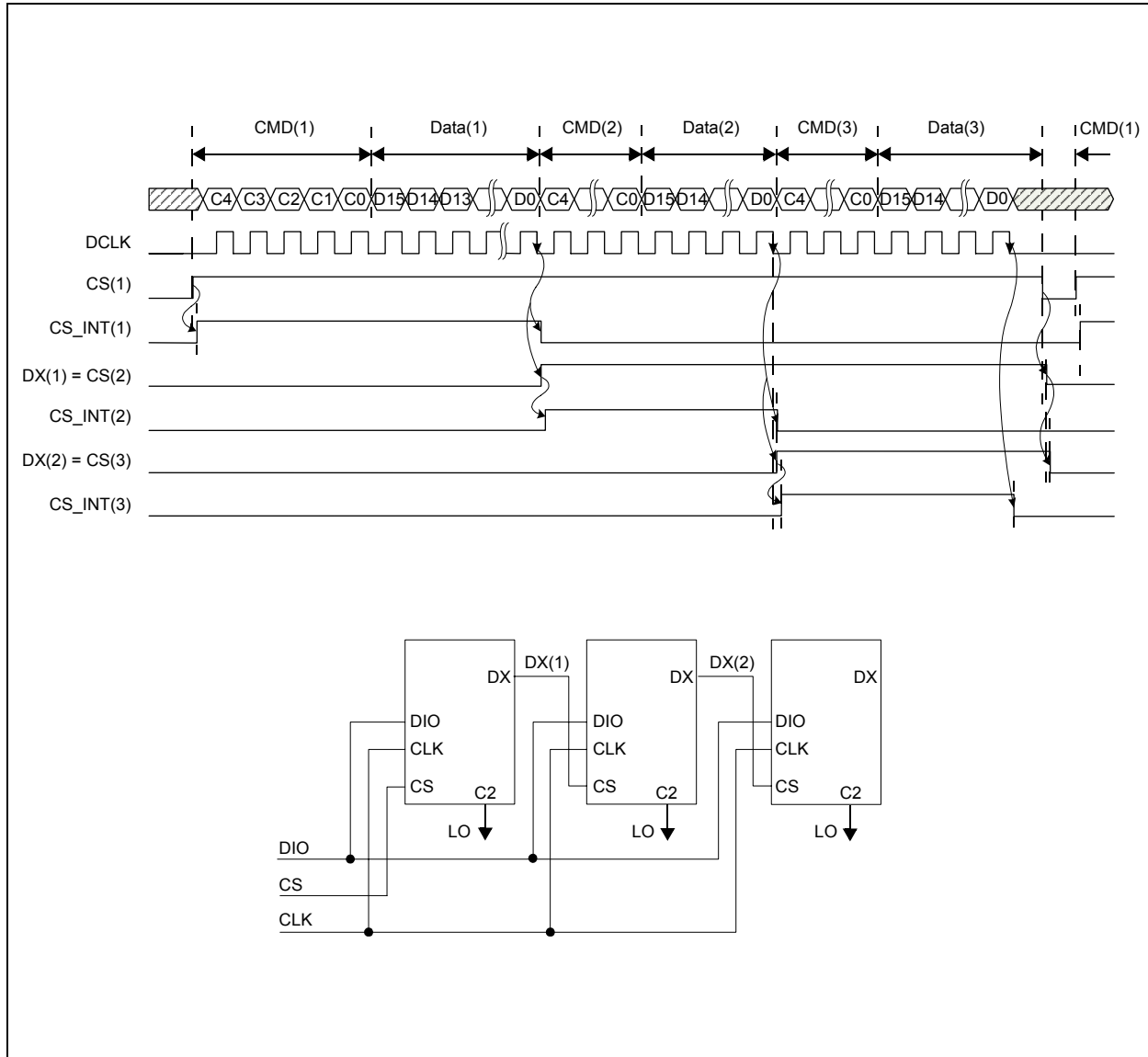

Waveform – Digital Interface @ Two Wire Daisy Chain Mode

Note: Defined, if the Pin C2 is set to LO @ all devices except the last one where the Pin C2 is set to HI

Figure 13. Two Wire Daisy Chain Mode

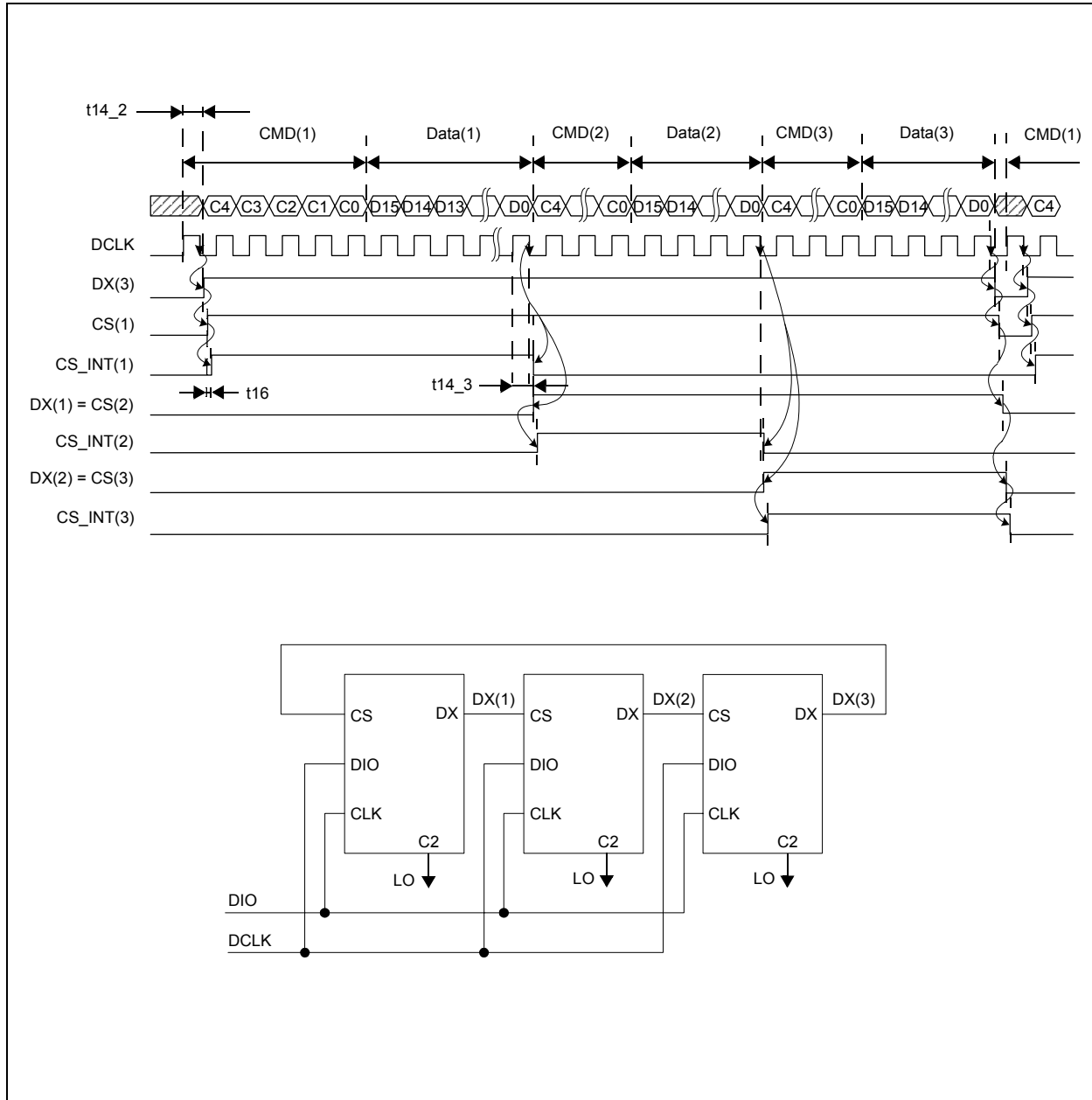

Serial Synchronous Interface (SSI)

Table 9. Commands of the SSI in Normal Mode

Digital interface @ normal mode																				
#	cmd	bin	mode	15	14	13	12	11	10	9	8	7	6	5	4	3	2	1	0	
23	WRITE CONFIG 1	10111	write	LP	tst	tst	tst	Hyst<1:0>		tst	tst	tst								
20	SET MT COUNTER	10100	write	multi-turn-counter <8:0>																
16	EN PROG	10000	write	1	0	0	0	1	1	0	0	1	0	1	0	1	1	1	1	0
4	RD MT COUNTER	00100	read	multi-turn-counter <8:0>										tst						
0	RD_ANGLE	00000	read	lock_adc	agc <5:0>						angle <8:0>									

EN PROG: Enables the access to the OTP register.

WRITE CONFIG: LP HI activates the sleep mode of the AS5134. The power consumption is significantly reduced. LP LO returns to normal operation mode. During sleep mode, the lock bit in command 0 and command 1 is LO.

RD_MT Counter: Command for read out of multi turn register.

RD_ANGLE: Command for read out of angle value and AGC value (agc). "Lock" indicates a locked ADC.

tst: Test bits for internal testing.

Hyst (11:10): Digital Hysteresis can be set via the digital interface 0,1,2 (default) 3 LSB; "On" after power-on reset

Hyst		Function	
0	0	2 LSB (default value)	
0	1	1	
1	0	3	
1	1	0	

SET MT COUNTER: Command for setting the Multi Turn Counter to a defined value.

LP: Default "0"; "1" for using the low power function.

lock_adc: Indicates that the tracking adc is in a locked status. Note that for valid angle conditions, the magnetic field has to be in a certain range, which is indicated by the agc_counter value.

Table 10. Commands of the SSI in Extended Mode

Digital interface @ extended mode																				
number of bits				2	18	1	1	4	2	1	4	2	3	1	Customer Settings					
															4	1	2	2	3	9
#	cmd	bin	mode	61..60	59..42	41	40	39..36	35..32	31	30..27	26..25	24..22	21	20..17	16	15..14	13..12	11..9	8..0
31	WRITE OTP	11111	extded write	tst	ID	hyst_2x	tst	tst	tst	FM	tst	tst	tst	lock_otp (*)	r_ad_d	r_bit	sensi	abi	uwv	zero angle
25	PROG_OTP	11001	extded write	tst	ID	hyst_2x	LP	tst	tst	LP	tst	tst	tst	lock_otp (*)	r_ad_d	r_bit	sensi	abi	uwv	zero angle
15	READ_OTP	01111	extded read	tst	ID	hyst_2x	LP	tst	tst	LP	tst	tst	tst	lock_otp (*)	r_ad_d	r_bit	sensi	abi	uwv	zero angle
9	READ ANA	01001	extded read	tst	ID	hyst_2x	LP	tst	tst	LP	tst	tst	tst	lock_otp (*)	r_ad_d	r_bit	sensi	abi	uwv	zero angle

WRITE OTP: Writing of the OTP register. The written data is volatile. "Zero Angle" is the angle, which is set for zero position. "Sensitivity" is the gain setting in the signal path. "Redundancy" is the number of bits, which allows the customer to overwrite one of the customer OTP bits <0:15>.

PROG_OTP: Programming of the OTP register. Only Bits <0:20> can be programmed by the customer. The internal factory settings are locked by an "internal lock bit" and cannot be programmed.

READ_OTP: Read out the content of the OTP register. Data written by WRITE_OTP and PROG_OTP is read out.

READ ANA: Analog read out mode. The analog value of every OTP bit is available at pin 1 (PROG), which allows for a verification of the fuse process. No data is available at the SSI.

tst: Test bits for internal testing

ID (59:42): Chip identifier to track the device in the field

hyst_2x (41): Increase the hysteresis two times (default = "0", 2x = "1")

FM (31): Fast mode → increase the oscillator frequency by 10%

lock_otp (21): To disable the programming of the factory bits – write access is still possible

r_add (20:17): The following OTP bits can be modified according to the requirements of the application.

r_bit (16): Redundancy bit (functionality is only implemented in the user region)

Sensitivity (15:14): Trim bit for the gain of the amplifier after the demodulator

abi (13:12): Mode selection for the incremental signals

uvw (11:9): Number of poles of the brush less dc motor - impact to the uvw signals

zero angle (8:0): Trim bit for the zero angle information

LP: Enables the low power mode to reduce the current consumption - digital registers are not reseted.

Notes:

1. Empty fields should be described with "logical 0".
2. These bits will be deleted during power down or sleep mode to ensure that the user is able to detect that the read out angle value is computed after the wake up sequence.

AS5134 Programming

The AS5134 offers the following user programmable options:

■ Zero Position Programming

This programming option allows the user to program any rotation angle of the magnet as the new zero position. This useful feature simplifies the assembly process as the magnet does not need to be mechanically adjusted to the electrical zero position. It can be assembled in any rotation angle and later matched to the mechanical zero position by zero position programming. The 8,5-bit user programmable zero position can be applied both temporarily (command WRITE OTP, #31) or permanently (command PROG OTP, #25).

■ Magnetic Field Optimization

This programming option allows the user to match the vertical distance of the magnet with the optimum magnetic field range of the AS5134 by setting the sensitivity level. The 2-bit user programmable sensitivity setting can be applied both temporarily (command WRITE OTP, #31) or permanently (command PROG OTP, #25).

■ Low Power Mode

Low Power Mode is a power saving mode with fast start-up. In Low Power Mode, all internal digital registers are frozen and the power consumption is reduced to max. 1,5 mA. Start-up from this mode to normal operation can be accomplished within 250µs. This mode is recommended for applications, where low power, but fast start-up and short reading cycle intervals are required.

OTP Programming Connection

Programming of the AS5134 OTP memory does not require a dedicated programming hardware. The programming can be simply accomplished over the serial 3-wire interface(see Figure 14) or the optional 2-wire interface(see Figure 6). For permanent programming (command PROG OTP, #25), a constant DC voltage of 8.0 – 8.5V (=100mA) must be connected to pin 1 (PROG). For temporary OTP write ("soft write"; command WRITE OTP, #31), the programming voltage is not required. The capacitors must be as close as possible to the pin, to ensure that a serial inductance of 50nH is not to be exceeded. The 50nH inductance could translate into a cable length of approximately 5cm.

Figure 14. OTP Programming Connection

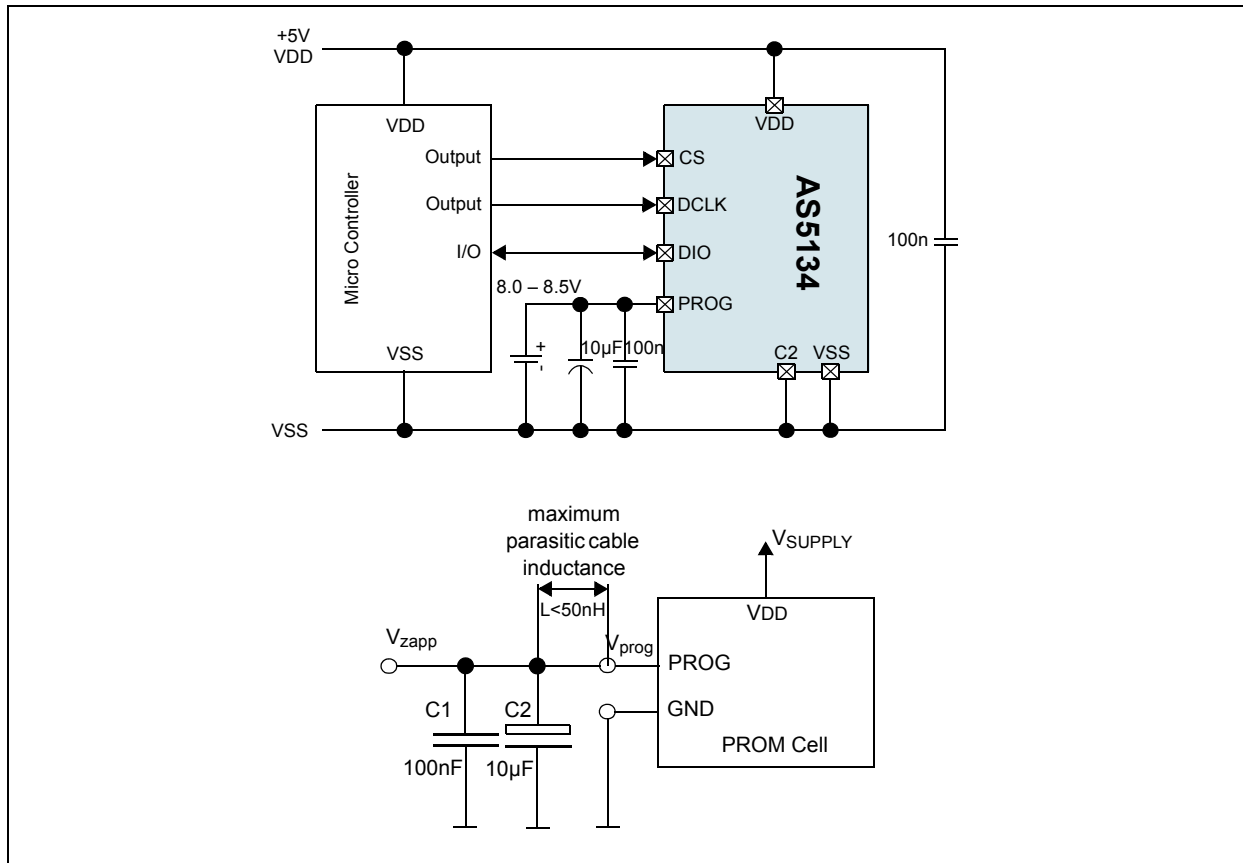

Programming Verification

After programming, the programmed OTP bits may be verified in two ways:

By Digital Verification: This is simply done by sending a READ OTP command (#15). The structure of this register is the same as for the OTP PROG or OTP WRITE commands.

By Analog Verification: By sending an ANALOG OTP READ command (#9), pin PROG becomes an output, sending an analog voltage with each clock, representing a sequence of the bits in the OTP register. A voltage of <math><500\text{mV}</math> indicates a correctly programmed bit ("1") while a voltage level between 2.2V and 3.5V indicates a correctly unprogrammed bit ("0"). Any voltage level in between indicates improper programming.

Figure 15. Analog OTP Verification

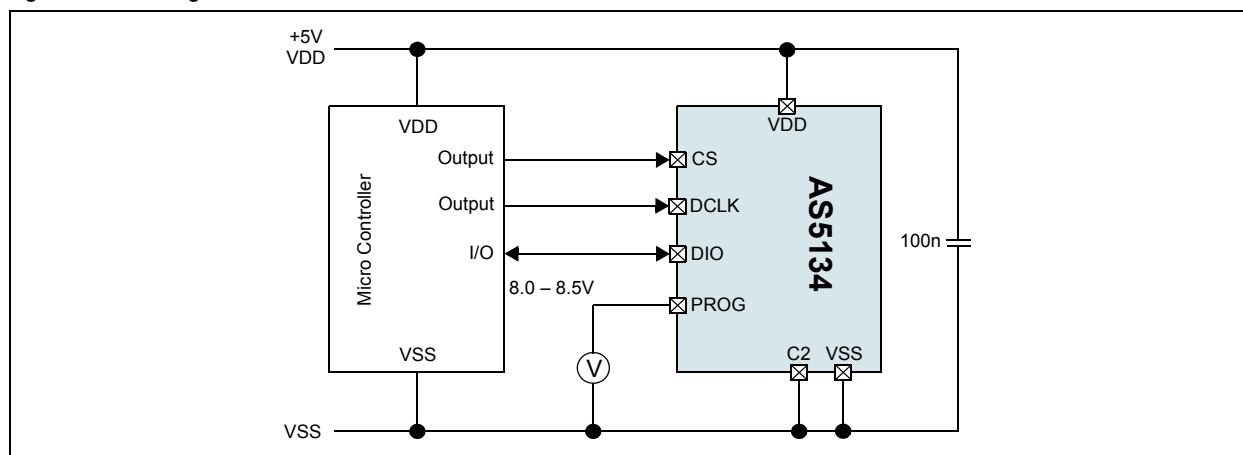
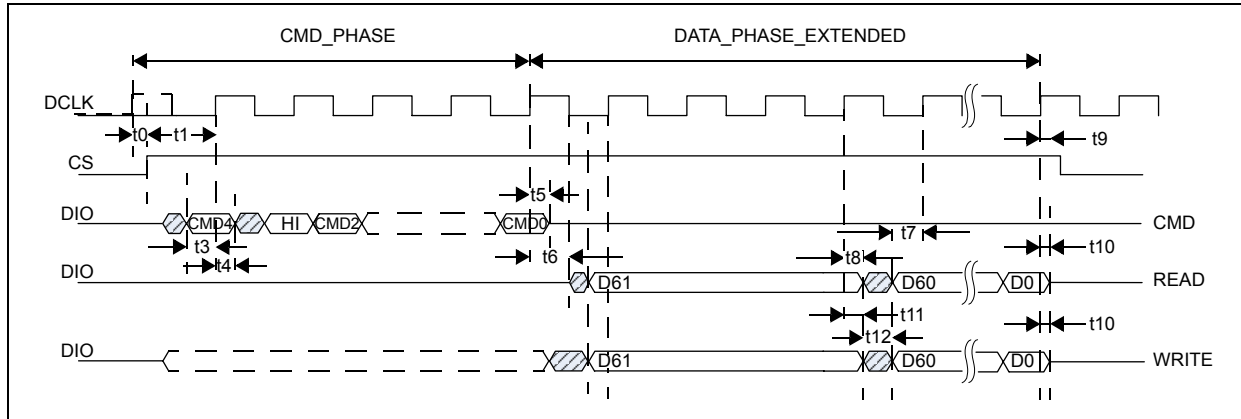

Figure 16. Extended Operation Mode (for OTP access only)



AS5134 Status Indicators

Lock Status Bit

The Lock signal indicates, whether the angle information is valid (ADC locked, Lock = high) or invalid (ADC unlocked, Lock = low). To determine a valid angular signal at best performance, the following indicators should be set:

Lock = 1

AGC = >00H and < 2FH

Note: The angle signal may also be valid (Lock = 1), when the AGC is out of range (00H or 2FH), but the accuracy of the AS5134 may be reduced due to the out of range condition of the magnetic field strength.

Magnetic Field Strength Indicators

The AS5134 is not only able to sense the angle of a rotating magnet, it can also measure the magnetic field strength (and hence the vertical distance) of the magnet. This additional feature can be used for several purposes:

- as a safety feature by constantly monitoring the presence and proper vertical distance of the magnet
- as a state-of-health indicator, e.g. for a power-up self test
- as a pushbutton feature for rotate-and-push types of manual input devices

The magnetic field strength information is available in two forms:

Magnetic Field Strength Software Indicator

The serial data that is obtained by command READ ANGLE contains the 6-bit AGC information. The AGC is an automatic gain control that adjusts the internal signal amplitude obtained from the Hall elements to a constant level. If the magnetic field is weak, e.g. with a large vertical gap between magnet and IC, with a weak magnet or at elevated temperatures of the magnet, the AGC value will be high. Likewise, the AGC value will be lower when the magnet is closer to the IC, when strong magnets are used and at low temperatures.

The best performance of the AS5134 will be achieved when operating within the AGC range. It will still be operational outside the AGC range, but with reduced performance especially with a weak magnetic field due to increased noise.

Factors Influencing the AGC Value

In practical use, the AGC value will depend on several factors:

- **The initial strength of the magnet.** Aging magnets may show a reducing magnetic field over time which results in an increase of the AGC value. The effect of this phenomenon is relatively small and can easily be compensated by the AGC.
- **The vertical distance of the magnet.** Depending on the mechanical setup and assembly tolerances, there will always be some variation of the vertical distance between magnet and IC over the lifetime of the application using the AS5134. Again, vertical distance variations can be compensated by the AGC.
- **The temperature and material of the magnet.** The recommended magnet for the AS5134 is a diametrically magnetized, 5-6mm diameter NdFeB (Neodymium-Iron-Boron) magnet. Other magnets may also be used as long as

they can maintain to operate the AS5134 within the AGC range. Every magnet has a temperature dependence of the magnetic field strength. The temperature coefficient of a magnet depends on the used material. At elevated temperatures, the magnetic field strength of a magnet is reduced, resulting in an increase of the AGC value. At low temperatures, the magnetic field strength is increased, resulting in a decrease of the AGC value. The variation of magnetic field strength over temperature is automatically compensated by the AGC.

OTP Sensitivity Adjustment

To obtain best performance and tolerance against temperature or vertical distance fluctuations, the AGC value at normal operating temperature should be in the middle between minimum and maximum, hence it should be around 100000 (20H). To facilitate the “vertical centering” of the magnet+IC assembly, the sensitivity of the AS5134 can be adjusted in the OTP register in 4 steps. A sensitivity adjustment is recommended, when the AGC value at normal operation is close to its lower limit (around 00H). The default sensitivity setting is 00_H = low sensitivity. Any value >00_H will increase the sensitivity (see Table 3).

Multi Turn Counter

A 9-bit register is used for counting the magnet’s revolutions. With each zero transition in any direction, the output of a special counter is incremented or decremented. The initial value after reset is 0 LSB. The multi turn value is encoded as complement on two. Clockwise rotation gives increasing angle values and positive turn count. Counter clockwise rotation exhibits decreasing angle values and a negative turn count respectively.

Bit Code	Decimal Value
01111111	256
---	---
01111111	127
---	---
00000011	+3
00000010	+2
00000001	+1
00000000	0
11111111	-1
11111110	-2
11111101	-3
---	---
10000000	-128
---	---
10000000	-255

The counter output can be reset by using command 20 – SET MT Counter. It is immediately reset by the rising clock edge of this bit. Any zero crossing between the clock edge and the next counter readout changes the counter value.

High Speed Operation

The AS5134 is using a fast tracking ADC (TADC) to determine the angle of the magnet. The TADC is tracking the angle of the magnet with cycle time of 2 μ s (typ. 1.4). Once the TADC is synchronized with the angle, it sets the LOCK bit in the status register. In worst case, usually at start-up, the TADC requires up to 255 steps (255 * 2 μ s = 510 μ s) to lock. Once it is locked, it requires only one cycle [2 μ s (typ. 1.4)] to track the moving magnet. The AS5134 can operate in locked mode at rotational speeds up to min. 25.000 rpm.

In Low Power Mode, the position of the TADC is frozen. It will continue from the frozen position once it is powered up again. If the magnet has moved during the power down phase, several cycles will be required before the TADC is locked again. The tracking time to lock in with the new magnet angle can be roughly calculated as:

$$t_{LOCK} = \frac{2\mu s * |NewAngle - OldAngle|}{1.406} \quad (EQ 1)$$

Where:

t_{LOCK} = Time required to acquire the new angle after power up from one of the reduced power modes [μs]

OldAngle = Angle position when one of the reduced power modes is activated [°]

NewAngle = Angle position after resuming from reduced power mode [°]

Propagation Delay

The Propagation delay is the time required from reading the magnetic field by the Hall sensors to calculating the angle and making it available on the serial or PWM interface. While the propagation delay is usually negligible on low speeds, it is an important parameter at high speeds. The longer the propagation delay, the larger becomes the angle error for a rotating magnet as the magnet is moving while the angle is calculated. The position error increases linearly with speed. The main factors that contribute to the propagation delay are discussed in detail further in this document.

ADC Sampling Rate

For high speed applications, fast ADC's are essential. The ADC sampling rate directly influences the propagation delay. The fast tracking ADC used in the AS5134 with a tracking rate of only 1.4 μs (typ) is a perfect fit for both high speed and high performance.

Chip Internal Lowpass Filtering

A commonplace practice for systems using analog-to-digital converters is to filter the input signal by an anti-aliasing filter. The filter characteristic must be chosen carefully to balance propagation delay and noise. The lowpass filter in the AS5134 has a cutoff frequency of typ. 23.8kHz and the overall propagation delay in the analog signal path is typ. 15.6 μs .

Digital Readout Rate

Aside from the chip-internal propagation delay, the time required to read and process the angle data must also be considered. Due to its nature, a PWM signal is not very usable at high speeds, as you get only one reading per PWM period. Increasing the PWM frequency may improve the situation but causes problems for the receiving controller to resolve the PWM steps. The frequency on the AS5134 PWM output is typ. 1.33kHz with a resolution of 2 μs /step. A more suitable approach for high speed absolute angle measurement is using the serial interface. With a clock rate of up to 6MHz, a complete set of data (21bits) can be read in >3.5 μs .

Total Propagation Delay of the AS5134

The total propagation delay of the AS5134 is the delay in the analog signal path and the tracking rate of the ADC:

$$15.6 + 1.4 = 17\mu s(\text{typ}) \quad (EQ 2)$$

If only the SIN-/COS-outputs are used, the propagation delay is the analog signal path delay only (typ. 15.6 μs).

Position Error Over Speed:

The angle error over speed caused by the propagation delay is calculated as:

$$\Delta\theta_{pd} = rpm * 6 * 17 * E^{-6} \text{ in degrees} \quad (EQ 3)$$

In addition, the anti-aliasing filter causes an angle error calculated as:

$$\Delta\theta_{pf} = \text{ArcTan} [rpm / (60 * f_0)] \quad (EQ 4)$$

Table 11. Examples of the Overall Position Error caused by Speed (includes both propagation delay and filter delay)

Speed (rpm)	Total Position Error ($\Delta\theta_{pd} + \Delta\theta_{pf}$)
100	0,0175°
1000	0,175°
10000	1,75°

Low Power Mode

The target of this mode is to reduce the long time power consumption of the device for battery powered applications, without losing the actual angle information.

In Low Power Mode, the AS5134 is inactive. The last state (for e.g. the angle, AGC value, etc.) is frozen and the chip starts from this frozen state when it resumes active operation. This method provides much faster start-up than a “cold start” from zero. If the AS5134 is cycled between active and reduced current mode, a substantial reduction of the average supply current can be achieved. The minimum dwelling time is <math><0.5\text{ ms}</math>. The actual active time depends on how much the magnet has moved while the AS5134 was in reduced power mode. The angle data is valid, when the status bit LOCK has been set. Once a valid angle has been measured, the AS5134 can be put back to reduced power mode. The average power consumption can be calculated as:

$$I_{avg} = \frac{I_{active} * t_{on} + I_{powerdown} * t_{off}}{t_{on} + t_{off}} \quad \text{sampling interval} = t_{on} + t_{off} \quad (EQ 5)$$

Where:

I_{avg} = Average current consumption

I_{active} = Current consumption in active mode

$I_{power_down} = I_{off}$: Current consumption in reduced power mode (max. 120 μ A)

t_{on} = Time period during which the chip is operated in active mode

t_{off} = Time period during which the chip is in reduced power mode

To access the Low Power Mode, the bit ‘LP’ <15> of the digital interface has to be set to “1”.

Figure 17. Low Power Mode Connection

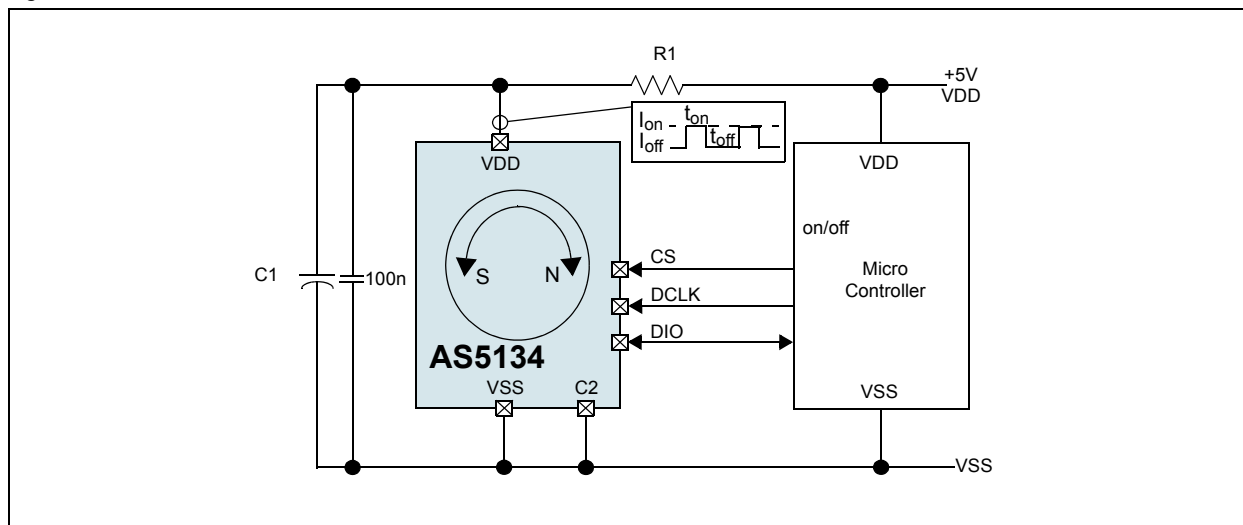

Reducing Power Supply Peak Currents

An optional RC-filter (R1/C1) may be added to avoid peak currents in the power supply line when the AS5134 is toggled between active and reduced power mode. R1 must be chosen such that it can maintain a VDD voltage of 4.5 – 5.5V under all conditions, especially during long active periods when the charge on C1 has expired. C1 should be chosen such that it can support peak currents during the active operation period. For long active periods, C1 should be large and R1 should be small.

Magnet Diameter and Vertical Distance

Note: Following is just an abstract taken from the elaborate application note on the Magnet.

For more detailed information, please visit our homepage www.austriamicrosystems.com → [Magnetic Rotary Encoders](#) → Magnet Application Notes

The Linear Range

The Hall elements used in the AS5000-series sensor ICs are sensitive to the magnetic field component B_z , which is the magnetic field vertical to the chip surface. [Figure 18](#) shows a 3-dimensional graph of the B_z field across the surface of a 6mm diameter, cylindrical NdFeB N35H magnet at an axial distance of 1mm between magnet and IC.

The highest magnetic field occurs at the north and south poles, which are located close to the edge of the magnet, at $\sim 2.8\text{mm}$ radius (see [Figure 19](#)). Following the poles towards the center of the magnet, the B_z field decreases very linearly within a radius of $\sim 1.6\text{mm}$. This linear range is the operating range of the magnet with respect to the Hall sensor array on the chip. For best performance, the Hall elements should always be within this linear range.

Figure 18. 3D-Graph of Vertical Magnetic Field of a 6mm Cylindrical Magnet

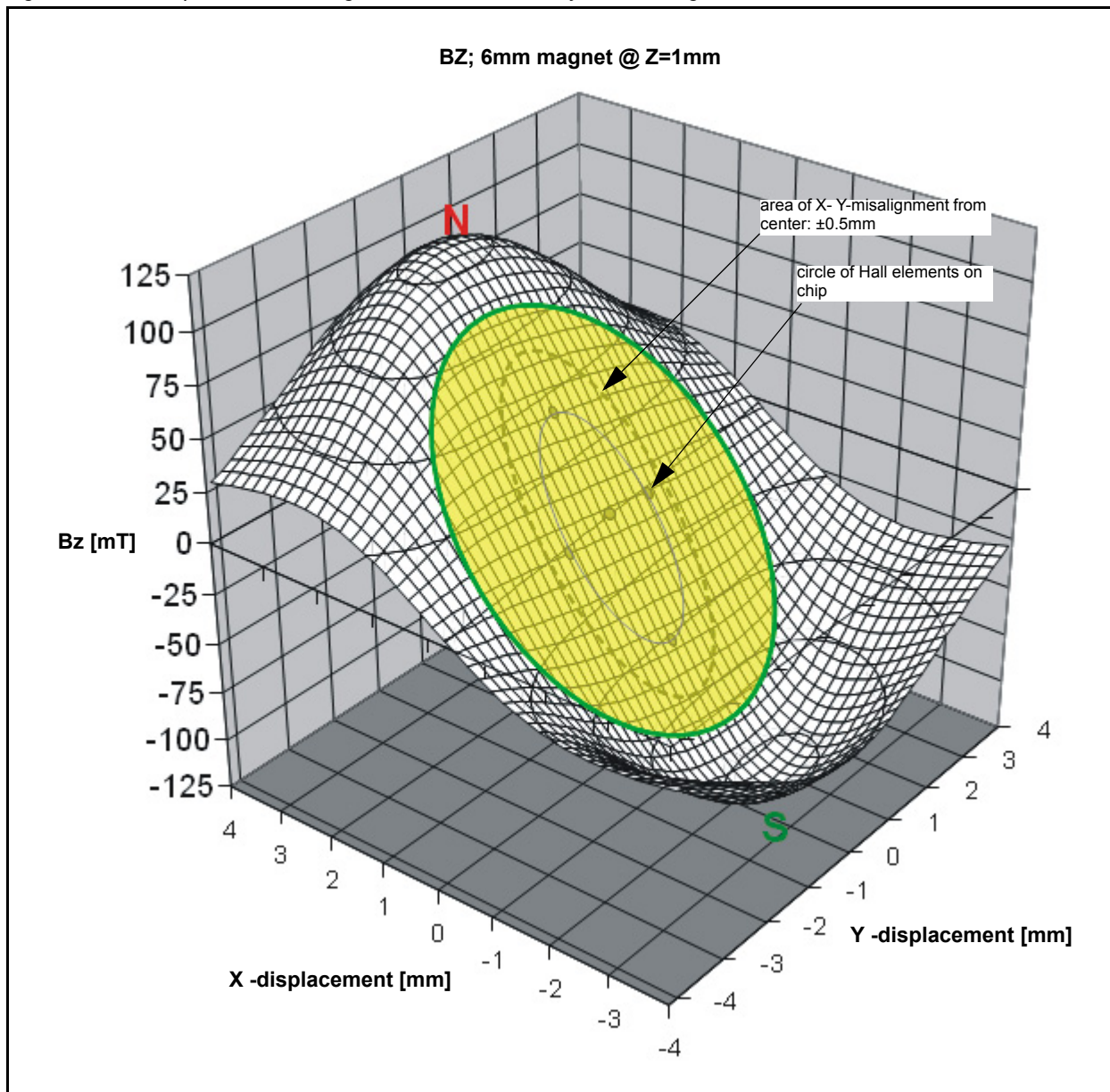

As shown in **Figure 19** (grey zone), the Hall elements are located on the chip at a circle with a radius of 1.1mm. Since the difference between two opposite Hall sensors is measured, there will be no difference in signal amplitude when the magnet is perfectly centered or if the magnet is misaligned in any direction as long as all Hall elements stay within the linear range.

For the 6mm magnet (shown in **Figure 19**), the linear range has a radius of 1.6mm, hence this magnet allows a radial misalignment of 0.5mm (1.6mm linear range radius; 1.1mm Hall array radius). Consequently, the larger the linear range, the more radial misalignment can be tolerated. By contrast, the slope of the linear range decreases with increasing magnet diameter, as the poles are further apart. A smaller slope results in a smaller differential signal, which means that the magnet must be moved closer to the IC (smaller airgap) or the amplification gain must be increased, which leads to a poorer signal – to – noise ratio. More noise results in more jitter at the angle output. A good compromise is a magnet diameter in the range of 5...8mm.

Small Diameter Magnet (<6mm)	Large Diameter Magnet (>6mm)
+++ stronger differential signal = good signal / noise ratio, larger airgaps	+++ wider linear range = larger horizontal misalignment area
--- shorter linear range = smaller horizontal misalignment area	-- weaker differential signal = poorer signal / noise ratio, smaller airgaps

Figure 19. Vertical Magnetic Field across the center of a Cylindrical Magnet

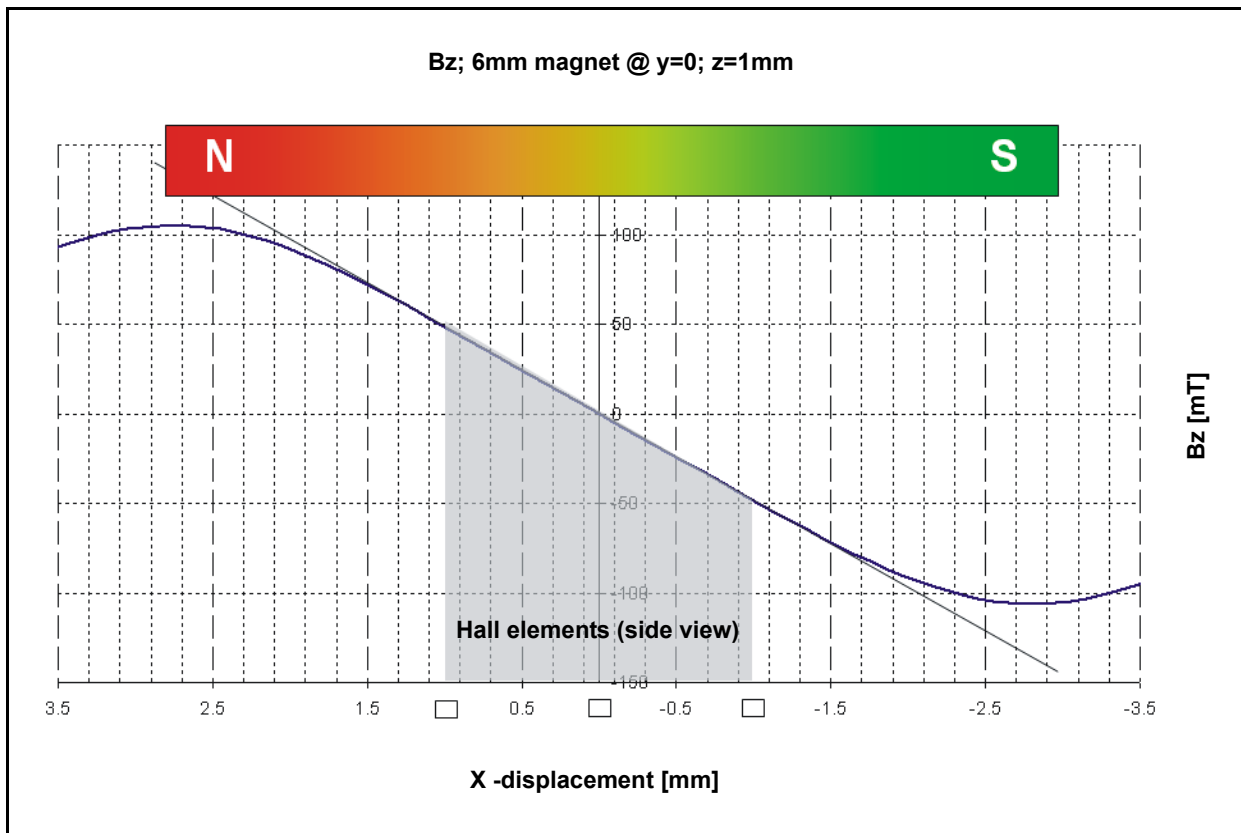

Magnet Thickness

Figure 20 shows the relationship of the peak amplitude in a rotating system (essentially the magnetic field strength of the Bz field component) in relation to the thickness of the magnet. The X-axis shows the ratio of magnet thickness (or height) [h] to magnet diameter [d] and the Y-axis shows the relative peak amplitude with reference to the recommended magnet (d=6mm, h=2.5mm). This results in an h/d ratio of 0.42.

Figure 20. Relationship of Peak Amplitude vs. Magnet Thickness

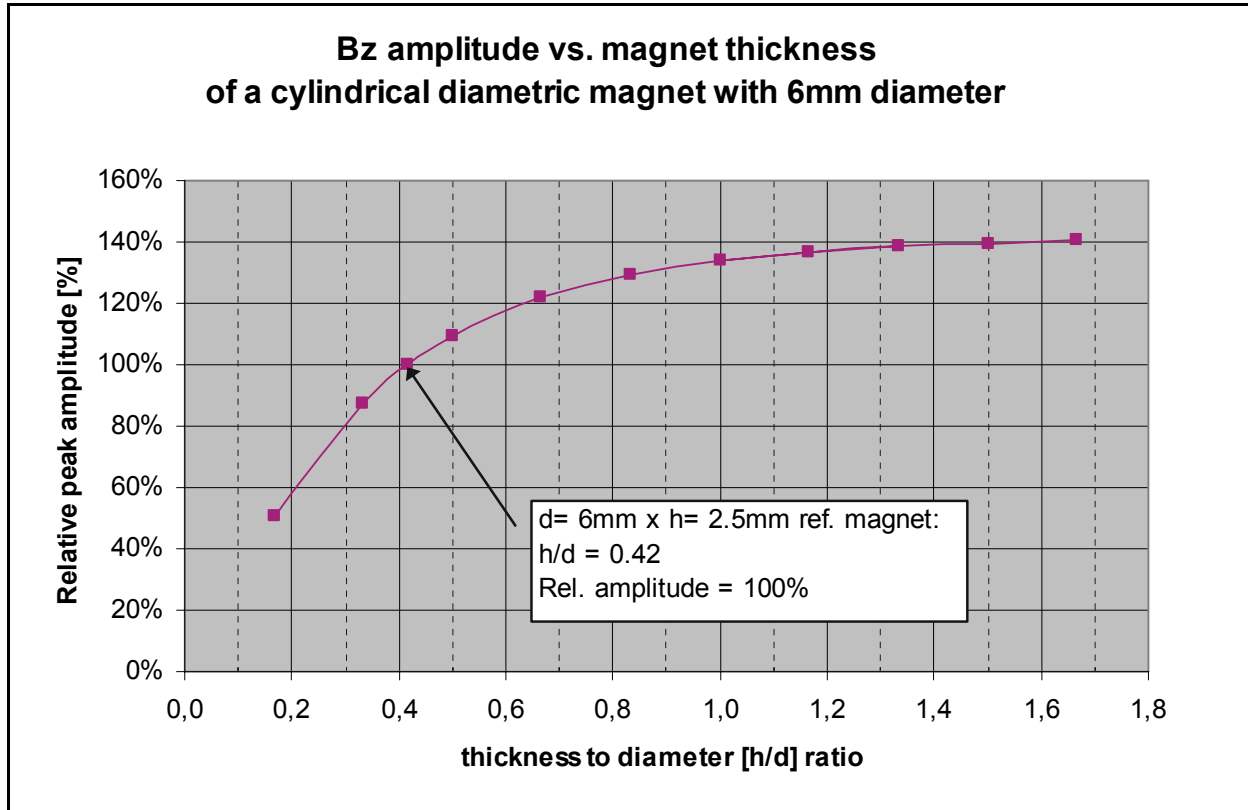

As the graph in Figure 20 shows, the amplitude drops significantly at h/d ratios below this value and remains relatively flat at ratios above 1.3.

Therefore, the recommended thickness of 2.5mm (@6mm diameter) should be considered as the low limit with regards to magnet thickness.

It is possible to get 40% or more signal amplitude by using thicker magnets. However, the gain in signal amplitude becomes less significant for h/d ratios $> \sim 1.3$. Therefore, the recommended magnet thickness for a 6mm diameter magnet is between 2.5 and ~ 8 mm.

Axial Distance (Airgap)

Figure 21. Sinusoidal Magnetic Field generated by the Rotating Magnet

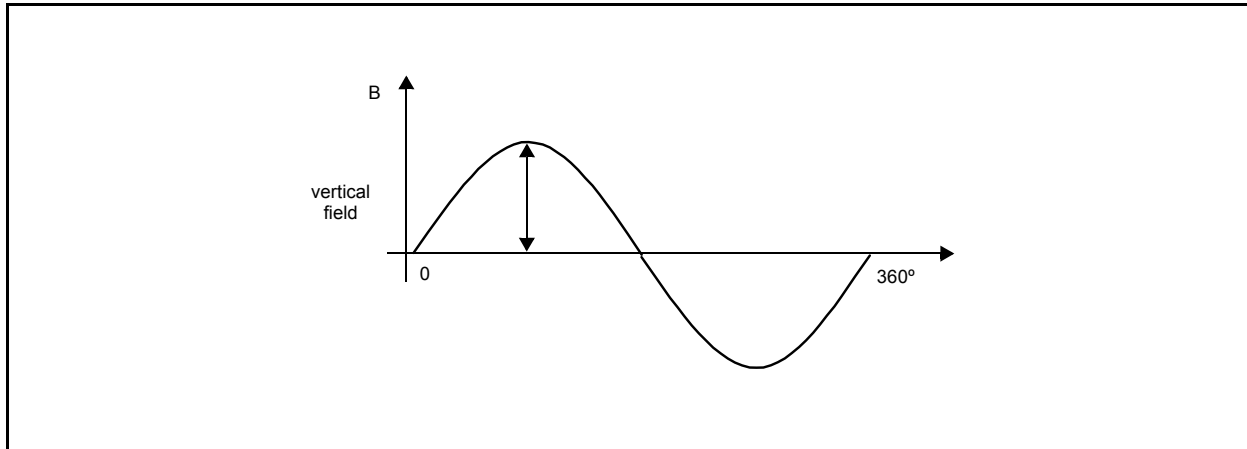

The recommended magnetic field, measured at the chip surface on a radius equal to the Hall sensor array radius (typ. 1.1mm) should be within a certain range. This range lies between 45 and 75mT or between 20 and 80mT, depending on the encoder product.

Linear position sensors are more sensitive as they use weaker magnets. The allowed magnetic range lies typically between 5 and 60mT.

Angle Error vs. Radial and Axial Misalignment

The angle error is the deviation of the actual angle vs. the angle measured by the encoder. There are several factors in the chip itself that contribute to this error, mainly offset and gain matching of the amplifiers in the analog signal path. On the other hand, there is the nonlinearity of the signals coming from the Hall sensors, caused by misalignment of the magnet and imperfections in the magnetic material.

Ideally, the Hall sensor signals should be sinusoidal, with equal peak amplitude of each signal. This can be maintained, as long as all Hall elements are within the linear range of the magnetic field B_z (see Figure 19).

Accuracy

Accuracy is defined as the error between the measured angle and the actual angle. It is influenced by several factors:

- the non-linearity of the analog-digital converters
- internal gain and mismatch errors
- non-linearity due to misalignment of the magnet

Misalignment of the magnet further reduces the accuracy. Figure 22 shows an example of a 3D-graph displaying non-linearity over XY-misalignment. The center of the square XY-area corresponds to a centered magnet. The X- and Y-axis extends to a misalignment of $\pm 1\text{mm}$ in both directions. The total misalignment area of the graph covers a square of $2 \times 2\text{ mm}$ (79x79mil) with a step size of $200\mu\text{m}$. The gap between surface and magnet is $z=500\mu\text{m}$.

Figure 22. 3D Graph Displaying Non-Linearity Over XY-Misalignment

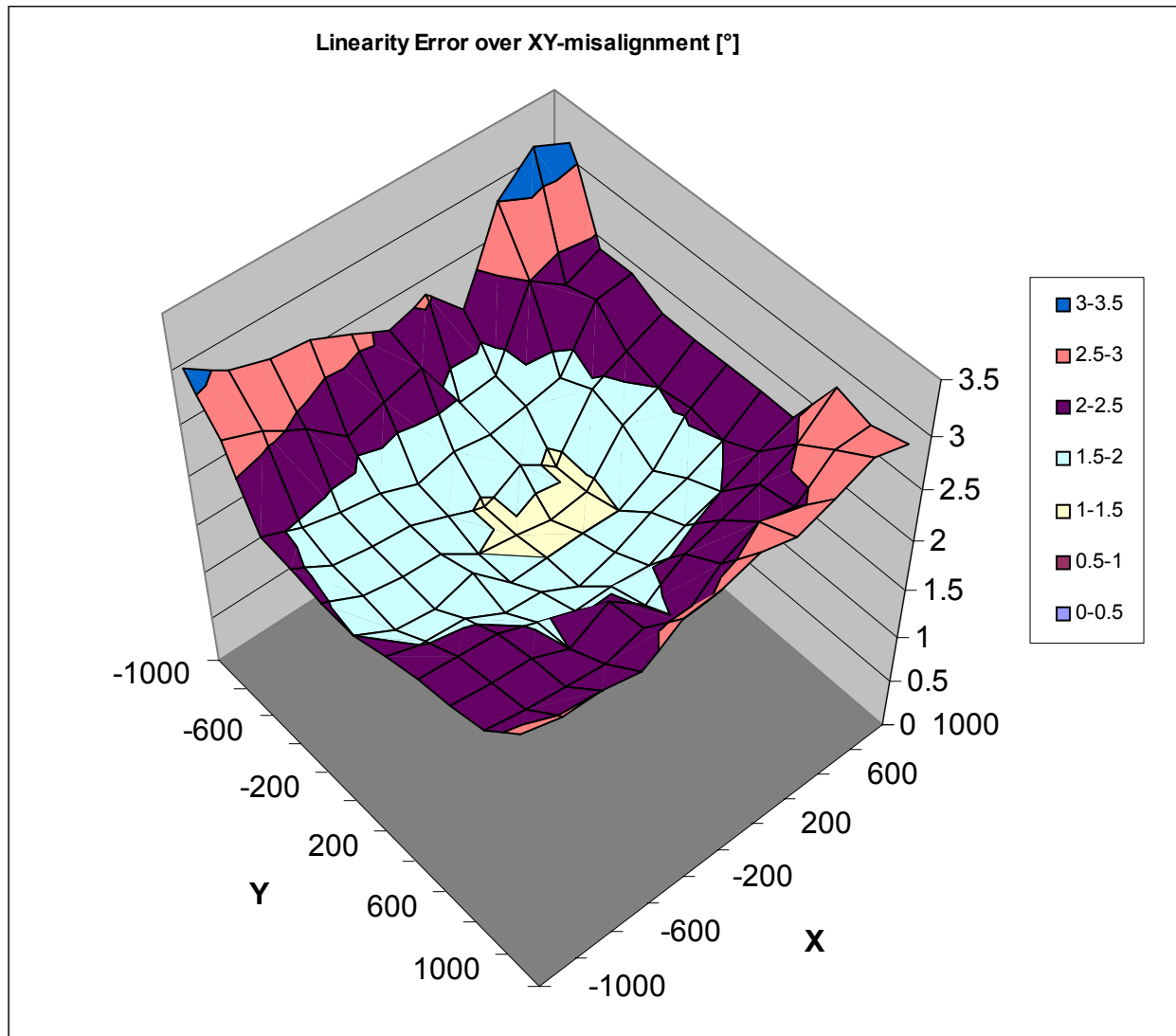

For volume production, the placement tolerance of the IC within the package ($\pm 0.235\text{mm}$) must also be taken into account. The total nonlinearity error over process tolerances, temperature and a misalignment circle radius of 0.25mm is specified better than ± 2 degrees.

The magnet used for this measurement is a cylindrical NdFeB (Bomatec® BMN-35H) magnet with 6mm diameter and 2.5mm in height.

Mounting the Magnet

Generally, for on-axis rotation angle measurement, the magnet must be mounted centered over the IC package. However, the material of the shaft into which the magnet is mounted, is also of big importance.

Magnetic materials in the vicinity of the magnet will distort or weaken the magnetic field being picked up by the Hall elements and cause additional errors in the angular output of the sensor.

Figure 23. Magnetic Field Lines in Air

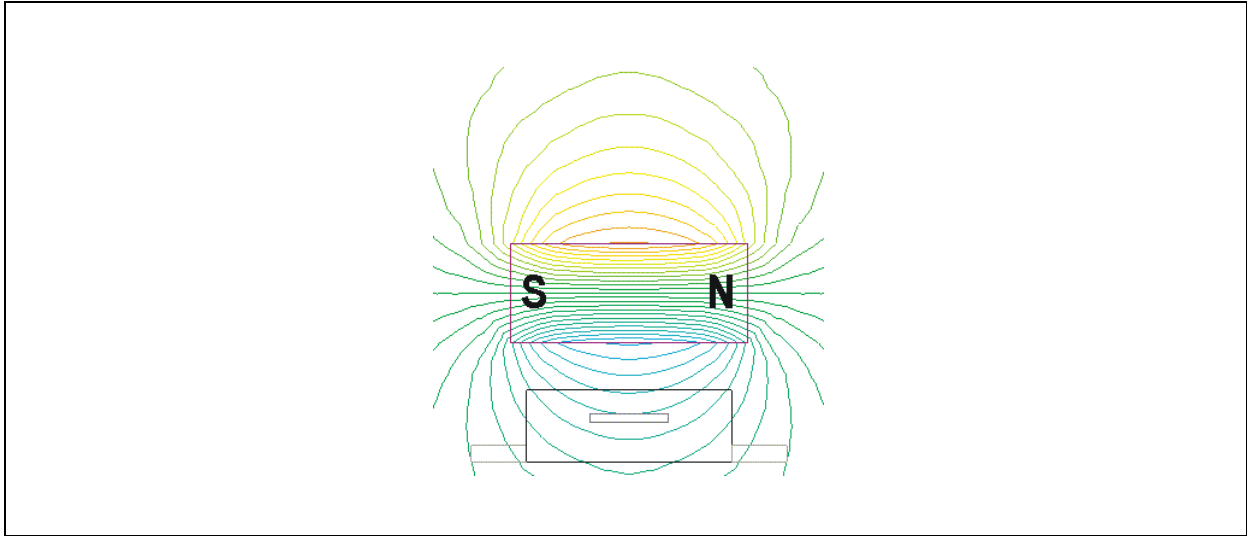
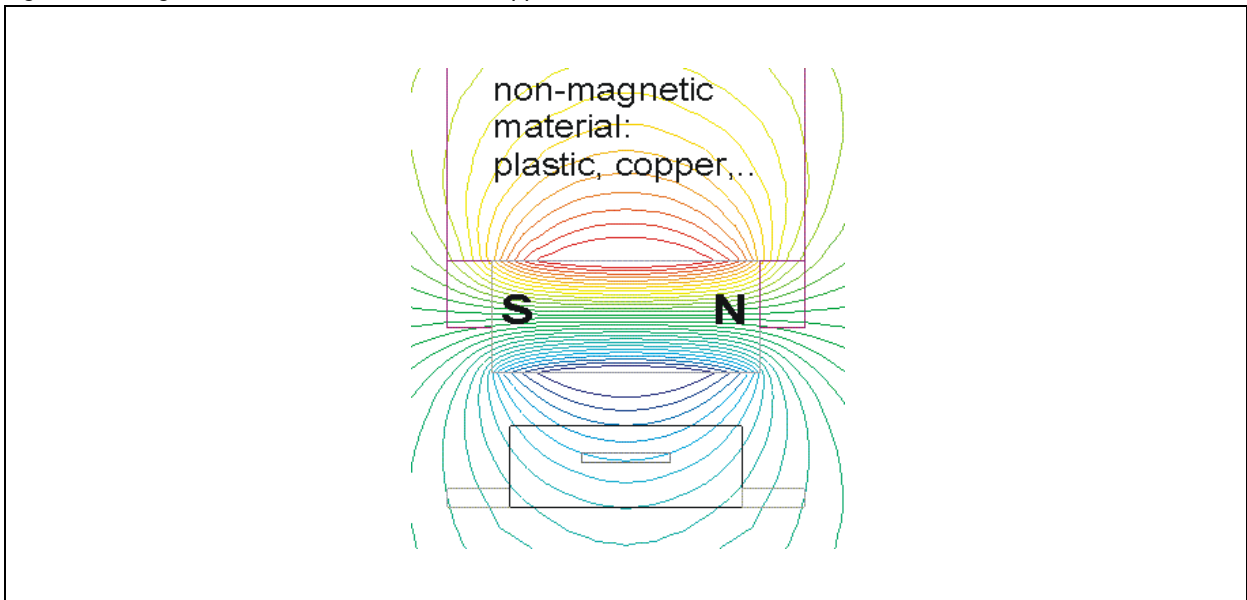

Figure 23 shows the ideal case with the magnet in air. No magnetic materials are anywhere nearby.

Figure 24. Magnetic Field Lines in Plastic or Copper Shaft



If the magnet is mounted in non-magnetic material, such as plastic or diamagnetic material, such as copper, the magnetic field distribution is not disturbed. Even paramagnetic material, such as aluminium may be used. The magnet may be mounted directly in the shaft (see Figure 24).

Note: Stainless steel may also be used, but some grades are magnetic. Therefore, steel with magnetic grades should be avoided.

Figure 25. Magnetic Field Lines in Iron Shaft

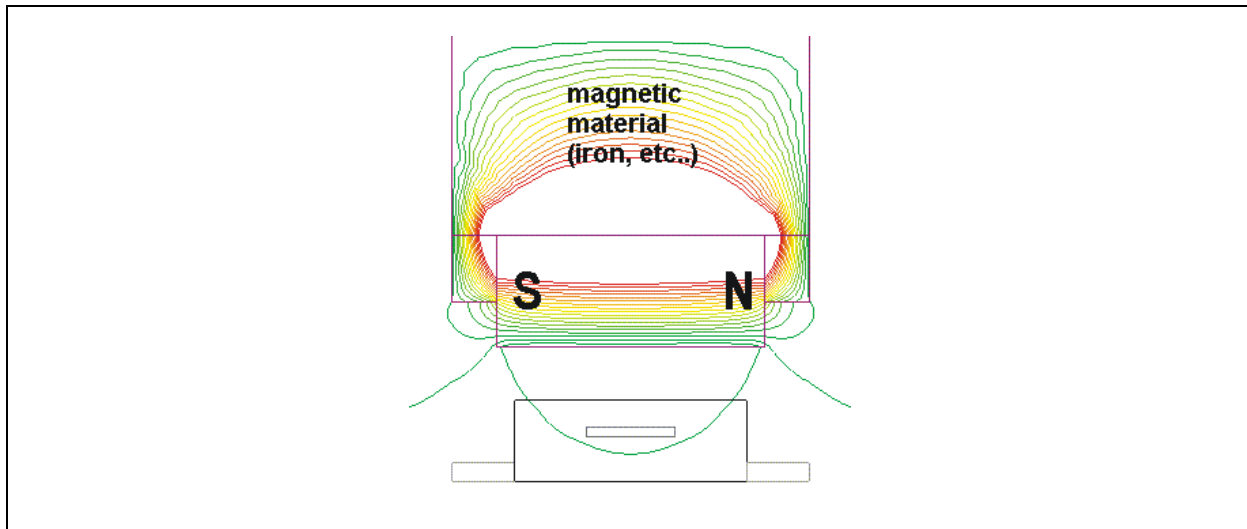

If the magnet is mounted in a ferromagnetic material, such as iron, most of the field lines are attracted by the iron and flow inside the metal shaft (see Figure 25). The magnet is weakened substantially.

This configuration should be avoided!

Figure 26. Magnetic Field Lines with Spacer between Magnet and Iron Shaft

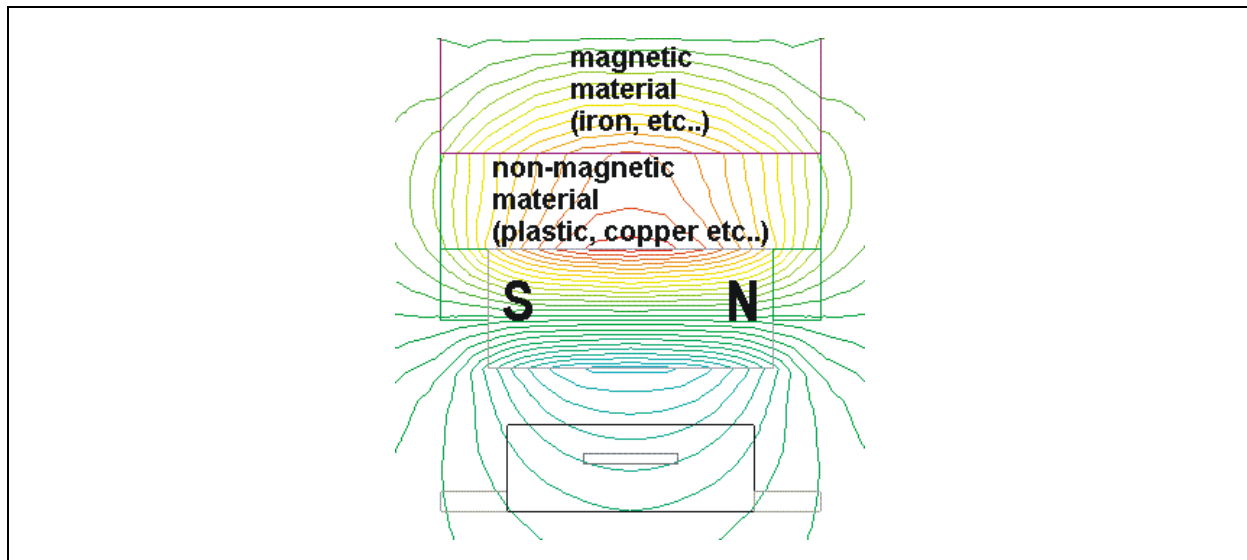

If the magnet has to be mounted inside a magnetic shaft, a possible solution is to place a non-magnetic spacer between shaft and magnet, as shown in Figure 26. While the magnetic field is rather distorted towards the shaft, there are still adequate field lines available towards the sensor IC. The distortion remains reasonably low.

Summary

- Small diameter magnets (<6mm Ø) have a shorter linear range and allow less lateral misalignment. The steeper slope allows larger axial distances.
- Large diameter magnets (>6 mm Ø) have a wider linear range and allow a wider lateral misalignment. The flatter slope requires shorter axial distances.
- The linear range decreases with airgap; Best performance is achieved at shorter airgaps.
- The ideal vertical distance range can be determined by using magnetic range indicators provided by the encoder ICs. These indicators are named MagInc, MagDec, MagRngn, or similar, depending on product.

8 Application Information

Benefits of AS5134

- Complete system-on-chip, no angle calibration required
- Flexible system solution provides absolute serial, ABI, UVW and PWM outputs
- Ideal for applications in harsh environments due to magnetic sensing principle
- High reliability due to non-contact sensing
- Robust system, tolerant to horizontal misalignment, airgap variations, temperature variations and external magnetic fields

AS5134 Parameter and Features List

Table 12. Parameter and Features List

Parameter	AS5134
Supply Voltage	4.5 to 5.5 V
Resolution	8.5 bit (360 steps, 1° per step)
Incremental outputs (ABI)	ABI quadrature: 90 ppr, (default) step/direction: 180 ppr (OTP option) fixed pulse width: 360ppr
BLDC outputs	UVW ; selectable for 1,2,3,4,5,6, pole pairs
Absolute output	Serial 2-wire (DCLK,DIO) with timeout sync Serial 3-wire (DCLK, CS, DIO) PWM output
Daisy Chain mode	Available for 2-wire and 3-wire serial modes
Automotive qualification	AEC Q-100, grade 1
Chip Identifier	18 bit
Ambient temperature	-40 to +140°C
ESD protection	±2kV
Propagation delay (in locked state)	Max 22µs
Transition noise (rms; 1 sigma)	0.24°
Integral Nonlinearity (INL), centered magnet	+/-2°
Multiturn Counter	9-bit (+256/-255 turns). Automatically updated during active mode at every 360°/0°-transition in each rotating direction. The multiturn counter can be accessed over the serial interface and is reset with a power-on-reset. It will be frozen at the last valid state in low power mode.
Low power mode	Non-operational. Last status is frozen in Low power mode to allow low power consumption and fast startup from low power mode to operating mode. Serial interface is active in low power mode to allow wakeup over the serial interface. PWM, incremental and BLDC outputs are invalid in low power mode, they remain at their last valid state. Current consumption in low power mode: typ. 30µA

Table 12. Parameter and Features List

Parameter	AS5134	
PWM output	2 μ s / step. 360° angle range in all modes. Minimum pos. pulse width (@0°) = 16 μ s (8 LSB; tbd) Minimum neg. pulse width (@359°) = 16 μ s (8 LSB; tbd) Pulse width @0° = 16 μ s, Pause = 734 μ s Pulse width @1° = 18 μ s, Pause = 732 μ s Pulse width @2° = 20 μ s, Pause = 730 μ s Pulse width @359° = 734 μ s, Pause = 16 μ s In case of an error (LOCK = Low), the pulse width is 8 μ s (4 LSB), pause = 742 μ s for all angles.	
Interface hardware	Incremental ABI interface: 3 pins BLDC UWV interface: 3 pins Absolute interface: 2 or 3 pins All outputs are available at the same time on separate pins	
Maximum speed; no missing codes	25.000 rpm	
Alignment tolerance	+/- 0.25 mm (reference to package center)	
Normal operating Current consumption	Typ 14mA; max 22mA	
Power-Up time	≤1.3 ms from cold start (no AGC), ≤4.1ms from cold start (AGC locked) <0.5ms from low power mode	
Serial Interface read options	360-step Angle (8.5-bit), 6-bit AGC, 9-bit Multiturn, ADC Lock	
Zero Position Programming	in OTP	
Serial interface program options	Incremental mode(quad ABI, step/dir) BLDC pole pairs (1,2,3,4,5,6) Zero Position Hall sensor sensitivity	
Serial interface write options (temporary write; will be lost with POR)	Incremental mode(quad ABI, step/dir) BLDC pole pairs (1,2,3,4,5,6) Zero Position Hall sensor sensitivity Multiturn counter reset to 00 Low power mode (on/off)	
IC package	SSOP-20	
Magnetic range software indicator	Field strength (AGC) readable through digital interface	
Magnetic input field range [mT]	20 – 80 mT	
BLDC Outputs		
BLDC outputs	3 separate digital outputs: U,V,W	
BLDC pole pair options	Selectable for 1,2,3,4,5,6, pole pairs	
Hysteresis on BLDC outputs	Same as incremental output hysteresis	
Switching positions	Pole pairs	Switching position steps
	1	60°
	2	30°
	3	20°

Table 12. Parameter and Features List

Parameter	AS5134	
	4	15°
	5	12°
	6	10°
Incremental Outputs		
Incremental modes	3 modes: Quad AB with Index (2x90 ppr), Step/direction (1x180 ppr) Fixed pulse width (360ppr)	
Step size	1°	
Incremental Hysteresis	0-3LSB; 2LSB (default)	
OTP Programming		
OTP programming technology	Zener Zapping	
OTP programming options	Zero position, Hall sensor sensitivity BLDC pole pairs (1,2,3,4,5,6) Incremental mode (quad AB, step/dir) Redundant Address Chip-Identifier	
OTP programming method	Over serial interface and static 8 - 8.5V Programming voltage at Pin PROG	
OTP programming verification	Digital and Analog	

9 Package Drawings and Markings

The device is available in a 20-pin SSOP package.

Figure 27. 20-pin SSOP Package Drawings

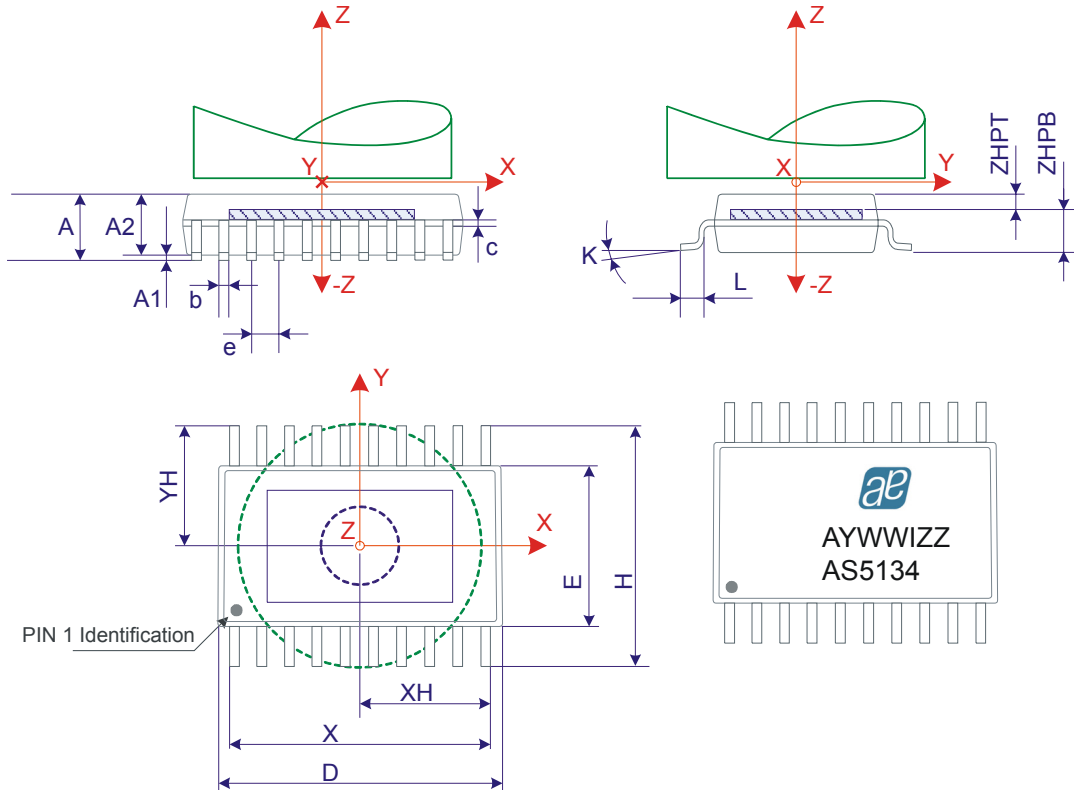

Table 13. 20-pin SSOP Package Dimensions

Symbol	mm			inch		
	Min	Typ	Max	Min	Typ	Max
A	1.73	1.86	1.99	0.068	0.073	0.078
A1	0.05	0.13	0.21	0.002	0.005	0.008
A2	1.68	1.73	1.78	0.066	0.068	0.070
b	0.25	-	0.38	0.010	-	0.015
D	7.07	7.20	7.33	0.278	0.284	0.289
E	5.20	5.30	5.38	0.205	0.209	0.212
e	0.65 BSC			0.0256 BSC		
H	7.65	7.80	7.90	0.301	0.307	0.311
K	0°	4°	8°	0°	4°	8°
L	0.63	0.75	0.95	0.025	0.030	0.037
X	-	$(10-1)*e + b$	-	-	$(10-1)e + b$	-
XH	$0.5*X - 0.235$	$0.5*X$	$0.5*X + 0.235$	$0.5*X - 9.25$	$0.5*X$	$0.5*X + 9.25$
YH	$0.5*E - 0.235$	$0.5*E$	$0.5*E + 0.235$	$0.5*E - 9.25$	$0.5*E$	$0.5*E + 9.25$
ZHPT	0.13	0.23	0.33	5.12	9.06	13
ZHPB	0.62	0.77	0.93	24.41	30.31	36.61

Recommended PCB Footprint

Figure 28. PCB Footprint

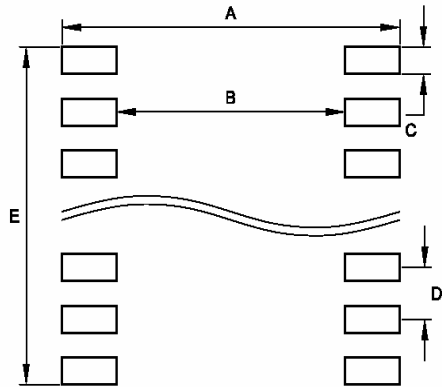

Table 14. Recommended Footprint Data

Symbol	mm	inch
A	9.02	0.355
B	6.16	0.242
C	0.46	0.018
D	0.65	0.025
E	6.31	0.248

10 Ordering Information

The devices are available as the standard products shown in [Table 15](#).

Table 15. Ordering Information

Model	Description	Delivery Form	Package
AS5134C-ZSST	High speed up to 25.000 rpm	Tape&Reel	SSOP20

Copyrights

Copyright © 1997-2008, austriamicrosystems AG, Schloss Premstaetten, 8141 Unterpremstaetten, Austria-Europe. Trademarks Registered ®. All rights reserved. The material herein may not be reproduced, adapted, merged, translated, stored, or used without the prior written consent of the copyright owner.

All products and companies mentioned are trademarks or registered trademarks of their respective companies.

Disclaimer

Devices sold by austriamicrosystems AG are covered by the warranty and patent indemnification provisions appearing in its Term of Sale. austriamicrosystems AG makes no warranty, express, statutory, implied, or by description regarding the information set forth herein or regarding the freedom of the described devices from patent infringement. austriamicrosystems AG reserves the right to change specifications and prices at any time and without notice. Therefore, prior to designing this product into a system, it is necessary to check with austriamicrosystems AG for current information. This product is intended for use in normal commercial applications. Applications requiring extended temperature range, unusual environmental requirements, or high reliability applications, such as military, medical life-support or life-sustaining equipment are specifically not recommended without additional processing by austriamicrosystems AG for each application. For shipments of less than 100 parts the manufacturing flow might show deviations from the standard production flow, such as test flow or test location.

The information furnished here by austriamicrosystems AG is believed to be correct and accurate. However, austriamicrosystems AG shall not be liable to recipient or any third party for any damages, including but not limited to personal injury, property damage, loss of profits, loss of use, interruption of business or indirect, special, incidental or consequential damages, of any kind, in connection with or arising out of the furnishing, performance or use of the technical data herein. No obligation or liability to recipient or any third party shall arise or flow out of austriamicrosystems AG rendering of technical or other services.



Contact Information

Headquarters

austriamicrosystems AG
A-8141 Schloss Premstaetten, Austria

Tel: +43 (0) 3136 500 0
Fax: +43 (0) 3136 525 01

For Sales Offices, Distributors and Representatives, please visit:

<http://www.austriamicrosystems.com/contact>