



## GS2974A HD-LINX™ III Adaptive Cable Equalizer

### Features

- SMPTE 424M, SMPTE 292M and SMPTE 259M compliant
- Automatic cable equalization
- 0.3UI Maximum Output Jitter at 2.97Gb/s
- Multi-standard operation from 143Mb/s to 2.97Gb/s
- Supports DVB-ASI at 270Mb/s
- Small footprint (4mm x 4mm)
- Pb-free and RoHS compliant
- Manual bypass (useful for low data rates with slow rise/fall times)
- Performance optimized for 1.485Gb/s and 2.97Gb/s
- Typical equalized length of Belden 1694A cable: 120m at 2.97Gb/s, 200m at 1.485Gb/s, and 350m at 270Mb/s
- 50Ω differential output (internal 50Ω pull-ups)
- Programmable mute based on max cable length adjust
- Single 3.3V power supply operation
- Operating temperature range: 0°C to +70°C

### Applications

- SMPTE 424M, SMPTE 292M and SMPTE 259M Coaxial Cable Serial Digital Interfaces.

### Description

The GS2974A is a high-speed BiCMOS integrated circuit designed to equalize and restore signals received over 75Ω co-axial cable.

The GS2974A is designed to support SMPTE 424M, SMPTE 292M and SMPTE 259M, and is optimized for performance at 1.485Gb/s and 2.97Gb/s.

The GS2974A features DC restoration to compensate for the DC content of SMPTE pathological test patterns.

A voltage programmable mute threshold (MCLADJ), applicable for SD mode (refer to [Section 4.3](#)), is included to allow muting of the GS2974A output when an approximate selected cable length is reached for SMPTE 259M signals. This feature allows the GS2974A to distinguish between low amplitude SD-SDI signals and noise at the input of the device. The serial digital outputs of the GS2974A may be forced to a mute state by applying a voltage to the MUTE pin.

Power consumption is typically 215mW using a 3.3V power supply. The GS2974A is lead-free, and the encapsulation compound does not contain halogenated flame retardant.

This component and all homogeneous subcomponents are RoHS compliant.

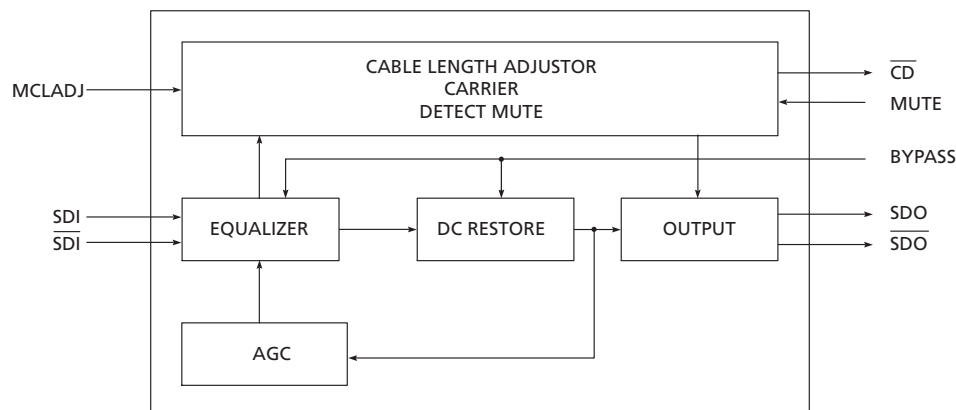

GS2974A Functional Block Diagram

## Revision History

Version	ECR	PCN	Date	Changes and/or Modifications
2	149719	-	April 2008	Added "0.3UI Maximum Output Jitter at 2.97Gb/s" to Features Section and Table 2-2: AC Electrical Characteristics. Changed cables lengths from 100 to 120 and 400 to 350 in Section 4. Detailed Description. Re-wrote Section 4.3 Programmable Maximum Cable Length Adjust (MCLADJ). Added Tape & Reel to 6.6 Ordering Information.
1	145131	-	May 2007	Converted to Data Sheet.
0	144247	-	February 2007	Converted to Preliminary Data Sheet. Removed 'Proprietary and Confidential' footer. Modified DC Electrical Characteristics and AC Electrical Characteristics table. Added section 6.4 Marking Diagram.
A	143102	-	December 2006	New Document.

# Contents

Features.....	1
Applications.....	1
Description.....	1
Revision History .....	2
1. Pin Out.....	4
1.1 GS2974A Pin Assignment .....	4
1.2 GS2974A Pin Descriptions .....	4
2. Electrical Characteristics .....	6
2.1 Absolute Maximum Ratings .....	6
2.2 DC Electrical Characteristics .....	6
2.3 AC Electrical Characteristics .....	7
Test Circuit .....	8
3. Input/Output Circuits .....	8
4. Detailed Description.....	9
4.1 Serial Digital Inputs .....	9
4.2 Cable Equalization .....	10
4.3 Programmable Maximum Cable Length Adjust (MCLADJ) .....	10
4.4 Mute and Carrier Detect .....	11
5. Application Information .....	12
5.1 PCB Layout .....	12
5.2 Typical Application Circuit .....	12
6. Package & Ordering Information.....	13
6.1 Package Dimensions .....	13
6.2 Packaging Data .....	13
6.3 Recommended PCB Footprint .....	14
6.4 Marking Diagram .....	14
6.5 Solder Reflow Profiles .....	15
6.6 Ordering Information .....	15

# 1. Pin Out

## 1.1 GS2974A Pin Assignment

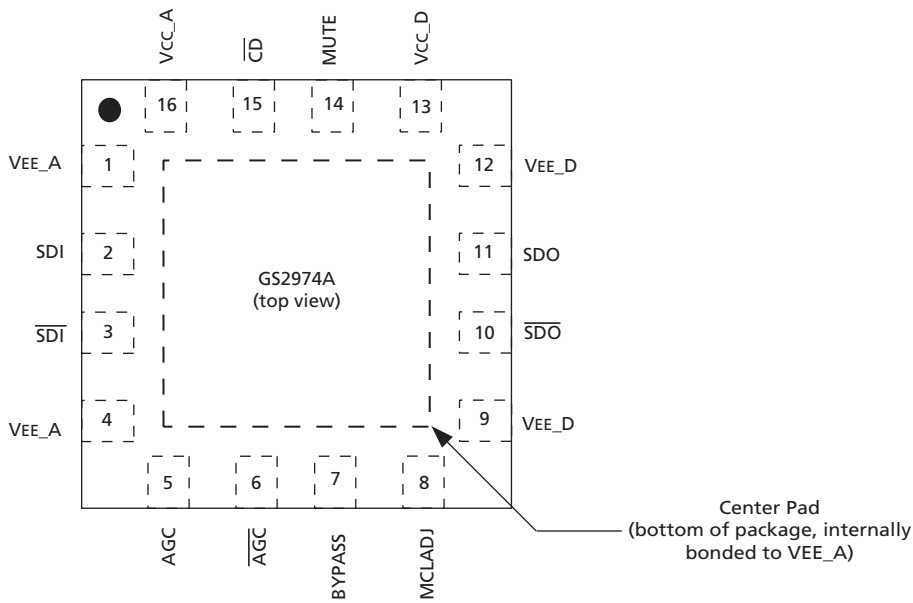

Figure 1-1: 16-Pin QFN

## 1.2 GS2974A Pin Descriptions

Table 1-1: GS2974A Pin Descriptions

Pin Number	Name	Timing	Type	Description
1, 4	VEE_A	Analog	Power	Most negative power supply for analog circuitry. Connect to GND.
2, 3	SDI, $\overline{\text{SDI}}$	Analog	Input	Serial digital differential input.
5, 6	AGC, $\overline{\text{AGC}}$	Analog	–	External AGC capacitor. Connect pin 5 and pin 6 together as shown in the <a href="#">Typical Application Circuit on page 12</a> .
7	BYPASS	Not Synchronous	Input	Forces the Equalizing and DC RESTORE stages into bypass mode when HIGH. No equalization occurs in this mode.
8	MCLADJ	Analog	Input	Maximum cable length adjust. Adjusts the approximate maximum amount of cable to be equalized. See <a href="#">Section 4.3</a> . and <a href="#">Section 4.4</a>
9	VEE_D	Analog	Power	Most negative power supply for the digital circuitry and output buffer. Connect to GND.

**Table 1-1: GS2974A Pin Descriptions (Continued)**

Pin Number	Name	Timing	Type	Description
10, 11	$\overline{SDO}$ , SDO	Analog	Output	Equalized serial digital differential output.
12	VEE_D	Analog	Power	Most negative power supply for the digital circuitry and output buffer. Connect to GND.
13	VCC_D	Analog	Power	Most positive power supply for the digital I/O pins of the device. Connect to +3.3V DC.
14	MUTE	Not Synchronous	Input	CONTROL SIGNAL INPUT levels are LVCMOS/LVTTL compatible. (3.3V Tolerant) Controls output behaviour on SDO and $\overline{SDO}$ See <a href="#">Section 4.4</a> .
15	$\overline{CD}$	Not Synchronous	Output	STATUS SIGNAL OUTPUT Signal levels are LVCMOS/LVTTL compatible. Indicates the presence of a good input signal. See <a href="#">Section 4.4</a> .
16	VCC_A	Analog	Power	Most positive power supply for the analog circuitry of the device. Connect to +3.3V DC.
–	Center Pad	–	Power	Internally bonded to VEE_A.

## 2. Electrical Characteristics

### 2.1 Absolute Maximum Ratings

Parameter	Value
Supply Voltage	-0.3V to +3.6 VDC
Input ESD Voltage	2kV
Storage Temperature Range	-50°C < T <sub>s</sub> < 125°C
Input Voltage Range (any input)	-0.3 to (V <sub>CC</sub> +0.3)V
Operating Temperature Range	0°C to 70°C
Solder Reflow Temperature	260°C

### 2.2 DC Electrical Characteristics

**Table 2-1: DC Electrical Characteristics**

V<sub>CC</sub> = 3.3V ±5%, T<sub>A</sub> = 0°C to 70°C, unless otherwise shown

Parameter	Symbol	Conditions	Min	Typ	Max	Units	Notes
Supply Voltage	V <sub>CC</sub>	–	3.135	3.3	3.465	V	±5%
Power Consumption	P <sub>D</sub>	T <sub>A</sub> = 25°C	–	215	343	mW	–
Supply Current	I <sub>s</sub>	T <sub>A</sub> = 25°C	–	65	98	mA	–
Output Common Mode Voltage	V <sub>CMOUT</sub>	T <sub>A</sub> = 25°C	–	V <sub>CC</sub> - ΔV <sub>SDO</sub> /2	–	V	–
Input Common Mode Voltage	V <sub>CMIN</sub>	T <sub>A</sub> = 25°C	–	1.75	–	V	–
MCLADJ DC Voltage (to mute signal)	–	0m, T <sub>A</sub> = 25°C	–	3.2	–	V	–
MCLADJ Range	–	T <sub>A</sub> = 25°C	–	0.5	–	V	–
CD Output Voltage	V <sub>CD(OH)</sub>	Carrier not present	2.4	–	–	V	–
	V <sub>CD(OL)</sub>	Carrier present	–	–	0.4	V	–
Mute Input Voltage Required to Force Outputs to Mute	V <sub>Mute</sub>	Min to Mute	2.0	–	–	V	–
Mute Input Voltage Required to Force Outputs Active	V <sub>Mute</sub>	Max to Activate	–	–	0.8	V	–

## 2.3 AC Electrical Characteristics

**Table 2-2: AC Electrical Characteristics**

$V_{CC} = 3.3V \pm 5\%$ ,  $T_A = 0^\circ C$  to  $70^\circ C$ , unless otherwise shown

Parameter	Symbol	Conditions	Min	Typ	Max	Units	Notes
Serial input data rate	$DR_{SDO}$	–	143	–	2970	Mb/s	–
Input Voltage Swing	$\Delta V_{SDI}$	$T_A = 25^\circ C$ , differential, 270Mb/s and 1.485Gb/s	720	800	950	mV <sub>p-p</sub>	1
		$T_A = 25^\circ C$ , differential, 2.97Gb/s	720	800	880	mV <sub>p-p</sub>	1
Output Voltage Swing	$\Delta V_{SDO}$	100 $\Omega$ load, $T_A = 25^\circ C$ , differential	550	750	1050	mV <sub>p-p</sub>	–
Output Jitter of Various Cable Lengths and Data Rates	–	270Mb/s Belden 1694A: 0-300m	–	–	0.2	UI	2,5
	–	270Mb/s Belden 1694A: 300-350m	–	0.2	–	UI	4,5
	–	1.485Gb/s Belden 1694A: 0-140m	–	–	0.25	UI	2,5
	–	1.485Gb/s Belden 1694A: 140-200m	–	0.3	–	UI	4,5
	–	2.97Gb/s Belden 1694A: 0-70m	–	–	0.3	UI	2,5
	–	2.97Gb/s Belden 1694A: 70-120m	–	0.3	–	UI	4,5
Output Rise/Fall time	–	20% - 80%	40	80	220	ps	–
Mismatch in rise/fall time	–	–	–	–	30	ps	–
Duty cycle distortion	–	–	–	–	30	ps	–
Overshoot	–	–	–	–	10	%	–
Input Return Loss	–	–	15	21	–	dB	3
Input Resistance	–	single ended	–	1.52	–	k $\Omega$	–
Input Capacitance	–	single ended	–	1	–	pF	–
Output Resistance	–	single ended	–	50	–	$\Omega$	–

**NOTES:**

1. 0m cable length.
2. All parts were production tested. In order to guarantee jitter over the full range of specification ( $V_{CC} = 3.3V \pm 5\%$ ,  $T_A = 0^\circ C$  to  $70^\circ C$ , and 720-880mV launch swing from the SDI cable driver) the recommended applications circuit must be used.
3. Tested on CB2974A board from 5MHz to 3GHz.
4. Based on characterization data using the recommended applications circuit, at  $V_{CC} = 3.3V$ ,  $T_A = 25^\circ C$  and 800mV launch swing from the SDI cable driver
5. Equalizer Pathological test signal was used.

## Test Circuit

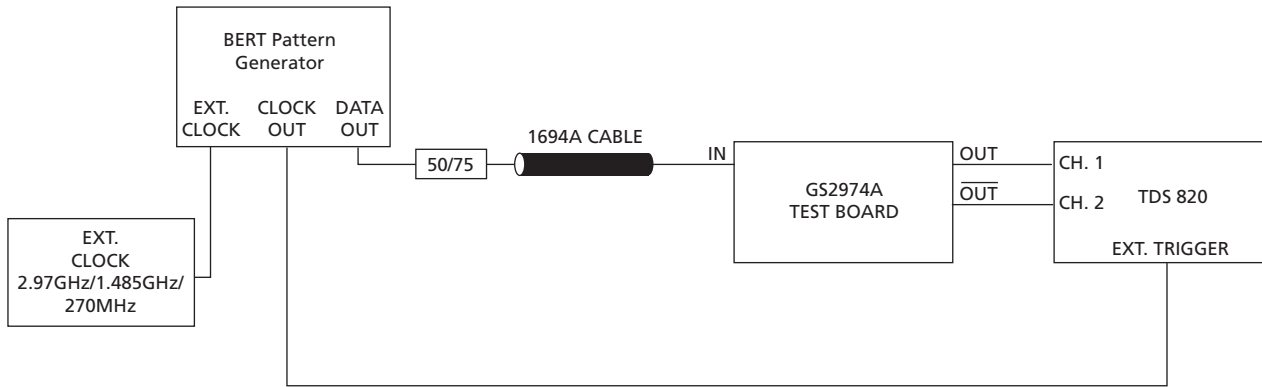

Figure 2-1: Test Circuit

## 3. Input/Output Circuits

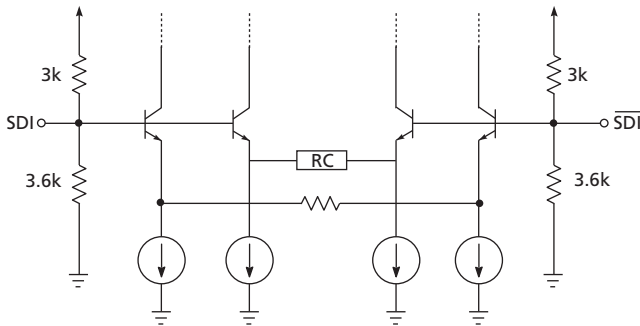

Figure 3-1: Input Equivalent Circuit

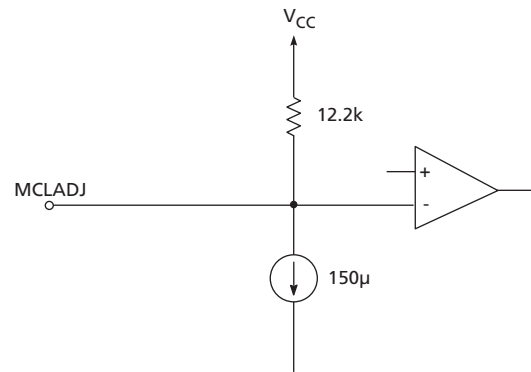

Figure 3-2: MCLADJ Equivalent Circuit



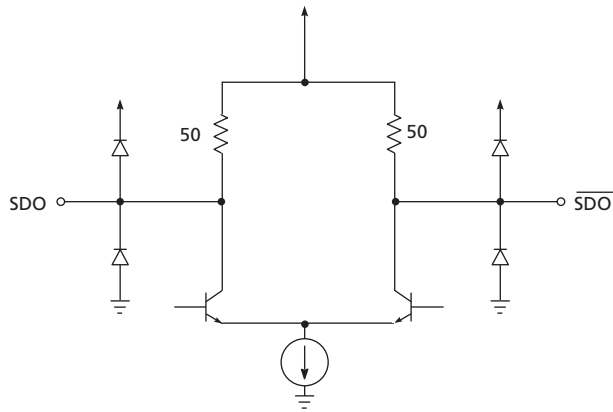

Figure 3-3: Output Circuit

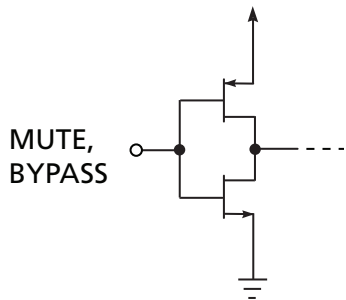

Figure 3-4: MUTE and BYPASS Circuits

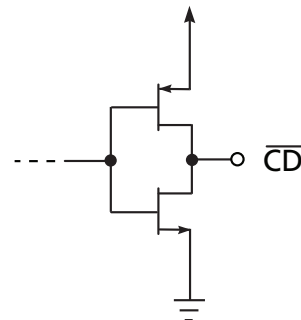

Figure 3-5:  $\overline{CD}$  Circuit

## 4. Detailed Description

The GS2974A is a high speed BiCMOS IC designed to equalize serial digital signals.

The GS2974A can equalize both HD and SD serial digital signals, and will typically equalize 120m of Belden 1694A cable at 2.97Gb/s, 200m at 1.485Gb/s and 350m at 270Mb/s. The GS2974A is powered from a single +3.3V power supply and consumes approximately 215mW of power.

### 4.1 Serial Digital Inputs

The serial data signal may be connected to the input pins ( $SDI/\overline{SDI}$ ) in either a differential or single-ended configuration. AC-coupling of the inputs is recommended, as the  $SDI$  and  $\overline{SDI}$  inputs are internally biased at approximately 1.8V.

## 4.2 Cable Equalization

The input signal passes through a variable gain equalizing stage whose frequency response closely matches the inverse of the cable loss characteristic. In addition, the variation of the frequency response with control voltage imitates the variation of the inverse cable loss characteristic with cable length.

The edge energy of the equalized signal is monitored by a detector circuit which produces an error signal corresponding to the difference between the desired edge energy and the actual edge energy. This error signal is integrated by both an internal and an external AGC filter capacitor providing a steady control voltage for the gain stage. As the frequency response of the gain stage is automatically varied by the application of negative feedback, the edge energy of the equalized signal is kept at a constant level which is representative of the original edge energy at the transmitter. The equalized signal is also DC restored, effectively restoring the logic threshold of the equalized signal to its correct level independent of shifts due to AC coupling. The digital output signals have a nominal voltage of  $750\text{mV}_{\text{pp}}$  differential, or  $375\text{mV}_{\text{pp}}$  single ended when terminated with  $50\Omega$  as shown in Figure 4-1.

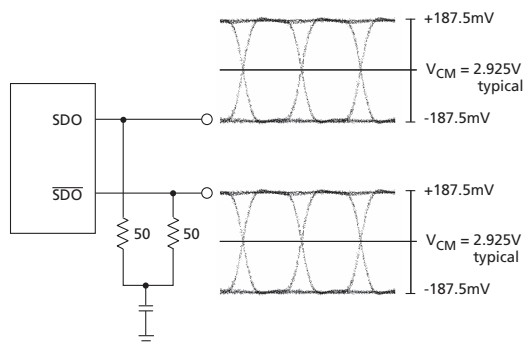

Figure 4-1: Typical Output Voltage Levels

## 4.3 Programmable Maximum Cable Length Adjust (MCLADJ)

For SMPTE 259M inputs, the GS2974A incorporates a programmable Maximum Cable Length Adjust (MCLADJ) threshold.

This feature can be useful in applications where there are multiple input channels using the GS2974A and the maximum gain can be limited to avoid crosstalk.

The MCLADJ pin acts to change the threshold of the Carrier Detect ( $\overline{\text{CD}}$ ) pin. When the input signal drops below a certain threshold, the  $\overline{\text{CD}}$  pin will be driven high, indicating that there is not a valid input signal. In order to enable automatic muting of the output of the GS2974A, the  $\overline{\text{CD}}$  pin should be connected directly to the MUTE pin. In applications where programmable maximum cable length adjust is not required, the MCLADJ pin may be left unconnected.

This feature has been designed for use in applications such as routers, where signal crosstalk and circuit noise cause the Equalizer to output erroneous data when no input signal is present. The use of a Carrier Detect function with a fixed internal reference

does not solve this problem, since the signal to noise ratio on the circuit board could be significantly less than the default signal detection level set by the on chip reference.

NOTE: MCLADJ is only recommended for data rates up to 360Mb/s. For data rates above this, MCLADJ should be left floating.

## 4.4 Mute and Carrier Detect

The GS2974A includes a MUTE input pin that allows the application interface to mute the serial digital output at any time. Set the MUTE pin HIGH to mute SDO and  $\overline{SDO}$ . In this case, the outputs will mute regardless of the setting of the BYPASS pin.

A Carrier Detect output pin ( $\overline{CD}$ ) indicates the presence of a valid signal at the input of the GS2974A. When  $\overline{CD}$  is LOW, the device has detected a valid input on SDI and  $\overline{SDI}$ . When  $\overline{CD}$  is HIGH, the device has not detected a valid input.

NOTE: This pin may be connected directly to the  $\overline{CD}$  pin to allow mute on loss of carrier.

NOTE:  $\overline{CD}$  will only detect loss of carrier for data rates greater than 19Mb/s. The  $\overline{CD}$  output pin may be connected directly to the MUTE input pin to enable automatic muting of the GS2974A when no valid input signal has been detected.

NOTE: If the maximum cable length is exceeded and the device is not in bypass mode the GS2974A will not assert the  $\overline{CD}$  pin even if a carrier is present.

**Table 4-1: Mute Input Table**

Mute	Function
0	SDO and $\overline{SDO}$ operate normally
1	SDO and $\overline{SDO}$ are forced to a steady state

**Table 4-2:  $\overline{CD}$  Output Table**

$\overline{CD}$	Input Status
0	Valid Input on SDI, $\overline{SDI}$ pins
1	Input is not valid

# 5. Application Information

## 5.1 PCB Layout

Special attention must be paid to component layout when designing serial digital interfaces for HDTV. An FR-4 dielectric can be used, however, controlled impedance transmission lines are required for PCB traces longer than approximately 1cm. Note the following PCB artwork features used to optimize performance:

- PCB trace width for HD rate signals is closely matched to SMT component width to minimize reflections due to change in trace impedance.
- The PCB ground plane is removed under the GS2974A input components to minimize parasitic capacitance.
- The PCB ground plane is removed under the GS2974A output components to minimize parasitic capacitance.
- High speed traces are curved to minimize impedance changes.

## 5.2 Typical Application Circuit

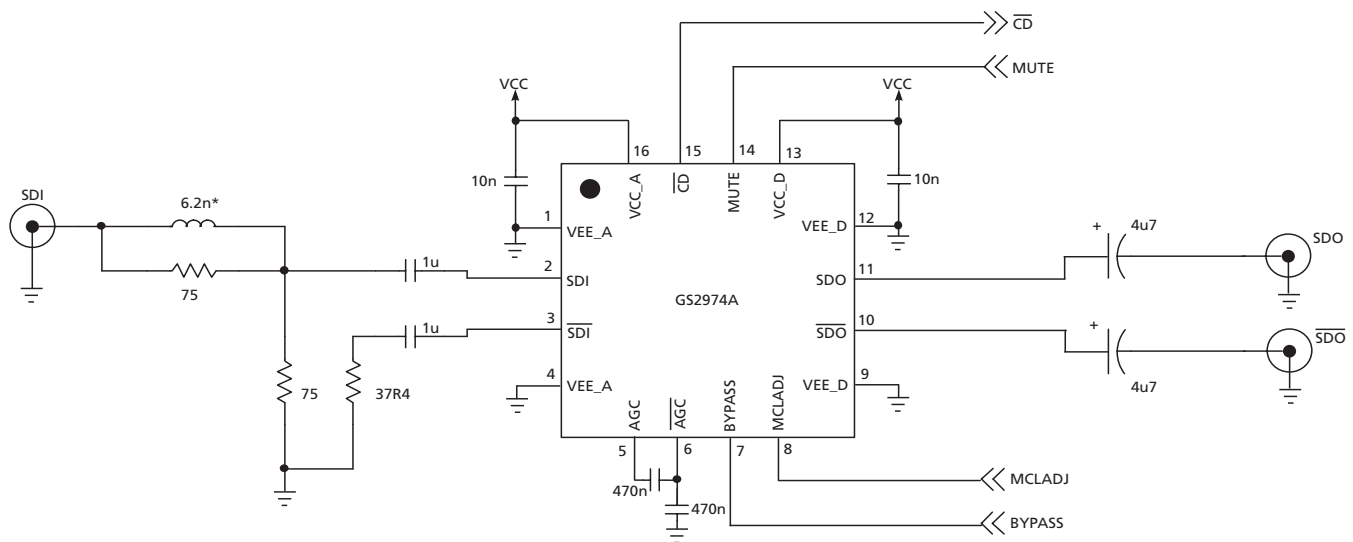

NOTE: All resistors in Ohms, capacitors in Farads, and inductors in Henrys, unless otherwise noted.  
\* Value dependent on layout

Figure 5-1: GS2974A Typical Application Circuit

# 6. Package & Ordering Information

## 6.1 Package Dimensions

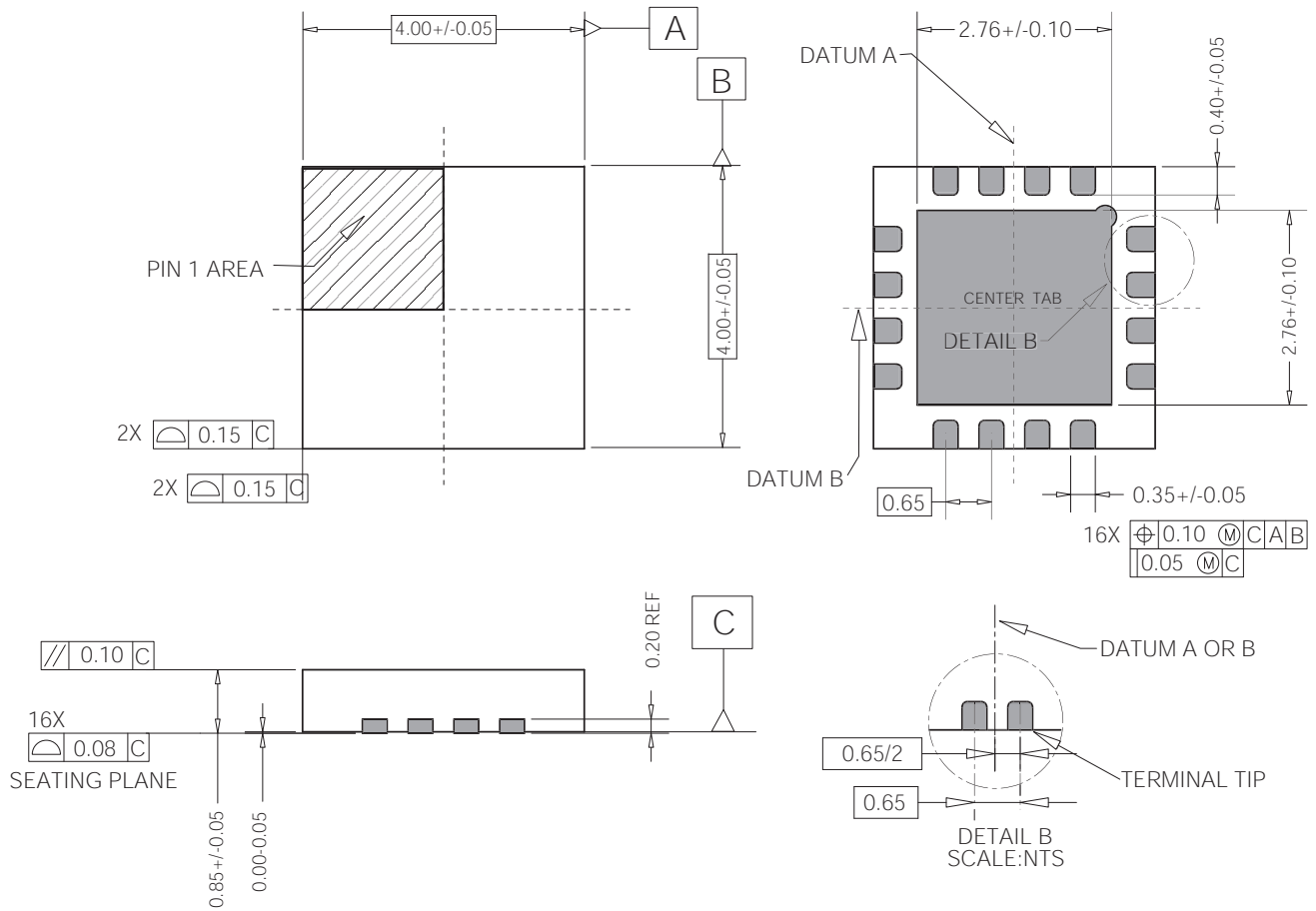

## 6.2 Packaging Data

Parameter	Value
Package Type	4mm x 4mm 16-pin QFN
Package Drawing Reference	JEDEC M0220
Moisture Sensitivity Level	3
Junction to Case Thermal Resistance, $\theta_{j-c}$	31.0°C/W
Junction to Air Thermal Resistance, $\theta_{j-a}$ (at zero airflow)	43.8°C/W
Psi, $\psi$	11.0°C/W
Pb-free and RoHS compliant	Yes

## 6.3 Recommended PCB Footprint

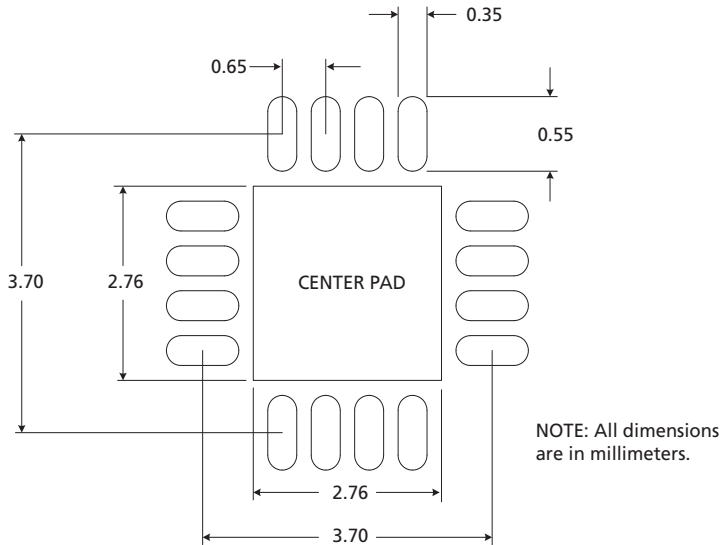

The Center Pad should be connected to the most negative power supply plane for analog circuitry in the device (VEE\_A) by a minimum of 5 vias.

NOTE: Suggested dimensions only. Final dimensions should conform to customer design rules and process optimizations.

## 6.4 Marking Diagram

Pin 1 ID



XXXX- Lot/Wrk Order ID

YYWW - Date Code

YY- 2-digit year

WW - 2-digit week number

## 6.5 Solder Reflow Profiles

The device is manufactured with Matte-Sn terminations and is compatible with both standard eutectic and Pb-free solder reflow profiles. MSL qualification was performed using the maximum Pb-free reflow profile shown in Figure 6-1. The recommended standard Pb reflow profile is shown in Figure 6-2.

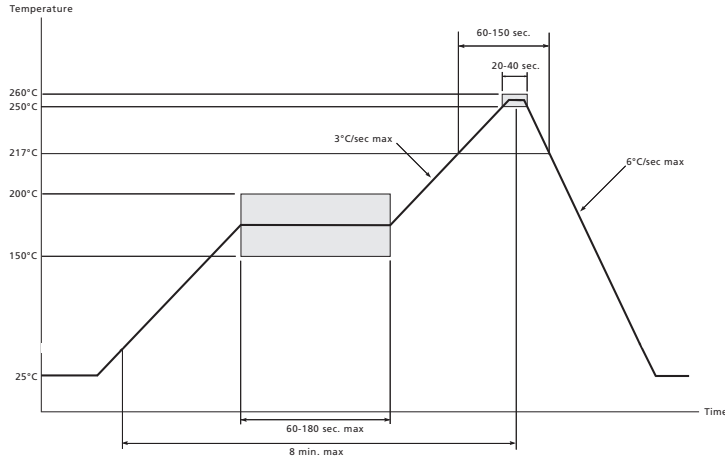

Figure 6-1: Maximum Pb-free Solder Reflow Profile (Preferred)

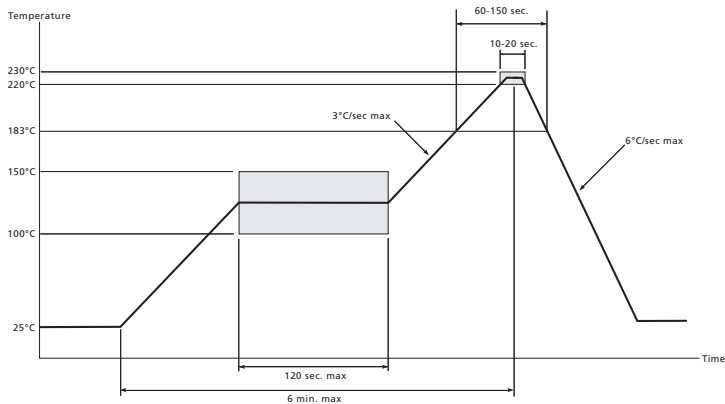

Figure 6-2: Standard Pb Solder Reflow Profile

## 6.6 Ordering Information

	Part Number	Package	Temperature Range
GS2974A	GS2974ACNE3	16-pin QFN	0°C to 70°C
GS2974A	GS2974ACTE3	16-pin QFN Tape & Reel (250pcs)	0°C to 70°C

---

**DOCUMENT IDENTIFICATION  
DATA SHEET**

The product is in production. Gennum reserves the right to make changes to the product at any time without notice to improve reliability, function or design, in order to provide the best product possible.

**CAUTION**

ELECTROSTATIC SENSITIVE DEVICES

DO NOT OPEN PACKAGES OR HANDLE EXCEPT AT A  
STATIC-FREE WORKSTATION

---

**GENNUM CORPORATION**

Mailing Address: P.O. Box 489, Station A, Burlington, Ontario L7R 3Y3 Canada

Street Addresses: 4281 Harvester Road, Burlington, Ontario L7L 5M4 Canada

Phone: +1 (905) 632-2996

Fax: +1 (905) 632-2055

Email: corporate@gennum.com

[www.gennum.com](http://www.gennum.com)

---

**OTTAWA DESIGN CENTRE**232 Herzberg Road, Suite 101  
Kanata, Ontario K2K 2A1  
Canada

Phone: +1 (613) 270-0458

Fax: +1 (613) 270-0429

**UNITED KINGDOM DESIGN CENTRE**North Building, Walden Court  
Parsonage Lane,  
Bishop's Stortford Hertfordshire, CM23 6DB  
Great Britain

Phone: +44 (1279) 714170

Fax: +44 (1279) 714171

**JAPAN KK**Shinjuku Green Tower Building 27F  
6-14-1, Nishi Shinjuku  
Shinjuku-ku, Tokyo, 160-0023  
Japan

Phone: +81 (03) 3349 5501

Fax: +81 (03) 3349 5505

Email: [gennum-japan@gennum.com](mailto:gennum-japan@gennum.com)Web Site: <http://www.gennum.co.jp>

---

**SNOWBUSH IP - A DIVISION OF GENNUM**439 University Ave. Suite 1700  
Toronto, Ontario M5G 1Y8  
Canada

Phone: +1 (416) 925-5643

Fax: +1 (416) 925-0581

Web Site: <http://www.snowbush.com>**AGUASCALIENTES PHYSICAL DESIGN  
CENTER**Venustiano Carranza 122 Int. 1  
Centro, Aguascalientes  
Mexico CP 20000

Phone: +1 (416) 848-0328

**GERMANY**Niederlassung Deutschland  
Stefan-George-Ring 29  
81929 München, Germany

Phone: +49 89 309040 290

Fax: +49 89 309040 293

Email: [gennum-germany@gennum.com](mailto:gennum-germany@gennum.com)

---

**UNITED STATES - WESTERN REGION**Bayshore Plaza  
2107 N 1st Street, Suite #300  
San Jose, CA 95131  
United States

Phone: +1 (408) 392-9430

Fax: +1 (408) 392-9404

**UNITED STATES - EASTERN REGION**4281 Harvester Road  
Burlington, Ontario L7L 5M4  
Canada

Phone: +1 (905) 632-2996

Fax: +1 (905) 632-2055

**TAIWAN**6F-4, No.51, Sec.2, Keelung Rd.  
Sinyi District, Taipei City 11502  
Taiwan R.O.C.

Phone: (886) 2-8732-8879

Fax: (886) 2-8732-8870

**KOREA**8F, Jinnex Lakeview Bldg.  
65-2, Bangidong, Songpagu  
Seoul, Korea 138-828

Phone: +82-2-414-2991

Fax: +82-2-414-2998

---

Gennum Corporation assumes no liability for any errors or omissions in this document, or for the use of the circuits or devices described herein. The sale of the circuit or device described herein does not imply any patent license, and Gennum makes no representation that the circuit or device is free from patent infringement.

All other trademarks mentioned are the properties of their respective owners.

GENNUM and the Gennum logo are registered trademarks of Gennum Corporation.

© Copyright 2006 Gennum Corporation. All rights reserved. Printed in Canada.

[www.gennum.com](http://www.gennum.com)