

AS3990/AS3991

Product Brief

UHF RFID Single Chip Reader EPC Class1 Gen2 Compatible

1 General Description

The AS3990/AS3991 UHF reader chip is an integrated analog front end and protocol handling system for a ISO18000-6C 900MHz RFID reader system.

Equipped with built-in programming options, the device is suitable for a wide range of applications in UHF RFID systems.

The reader configuration is achieved by selecting the desired protocol in control registers. Direct access to all control registers also allows fine tuning of different reader parameters, if needed.

Parallel or serial interface can be selected for communication between the host system (MCU) and the reader IC. When hardware coders and decoders are used, transmission and receive data is transferred via. 24 bytes FIFO register.

In case of direct transmission or reception, coders and decoders are bypassed and the host system has to service the analog front end in real time.

The transmitter generates 20dBm output power into 50Ω load and is capable of ASK or PR-ASK modulation. The integrated supply voltage regulators ensure supply rejection of the complete reader system.

The transmission system comprises low level data coding. Automatic generation of FrameSync, Preamble, and CRC is supported.

The receiver system allows AM and PM demodulation. The receiver also comprises automatic gain control option (patent pending) and selectable gain and signal bandwidth to cover a range of input link frequency and bit rate options.

The signal strength of AM and PM modulation is measured and can be accessed in RSSI register.

The receiver output is selectable between digitized sub-carrier signal and any of integrated sub-carrier decoders. Selected decoders deliver bit stream and data clock as outputs.

The receiver system also comprises framing system. This system performs the CRC check and organizes the data in bytes. Framed data is accessible to the host system through a 24 byte FIFO register.

To support external MCU and other circuitry a 3.3V regulated supply and clock outputs are available. The regulated supply has 20mA current capability.

The AS3990/AS3991 is available in a 64 pin QFN (9mm x 9mm), ensuring the smallest possible footprint.

2 Key Features

- ISO18000-6C (EPC Gen2) full protocol support
- ISO18000-6A,B compatibility in direct mode
- Integrated low level transmission coding
- Integrated low level decoders
- Integrated data framing
- Integrated CRC checking
- Parallel 8-bit or serial 4 pin SPI interface to MCU using 24 bytes FIFO
- Voltage range for communication to MCU between 1.8V and 5.5V
- Selectable clock output for MCU
- Integrated supply voltage regulator (20mA), which can be used to supply MCU and other external circuitry
- Integrated supply voltage regulator for the RF output stage, providing rejection to supply noise
- Internal power amplifier (20dBm) for short range applications
- Modulator using ASK or PR-ASK modulation
- Adjustable ASK modulation index
- AM & PM demodulation ensuring no "communication holes" with automatic I/Q selection
- Built in reception low-pass and high-pass filters having selectable corner frequencies
- Selectable reception gain
- Reception automatic gain control
- AD converter for measuring TX power using external RF power detector
- DA converter for controlling external power amplifier
- Frequency hopping support
- On-board VCO and PLL covering complete RFID frequency range 840MHz to 960MHz
- Oscillator using 20MHz crystal
- Power down, standby and active mode
- Can be powered by USB with no need for step conversion

3 Applications

The device is an ideal solution for UHF RFID reader systems and hand-held UHF RFID readers.

Figure 1. Block Diagram

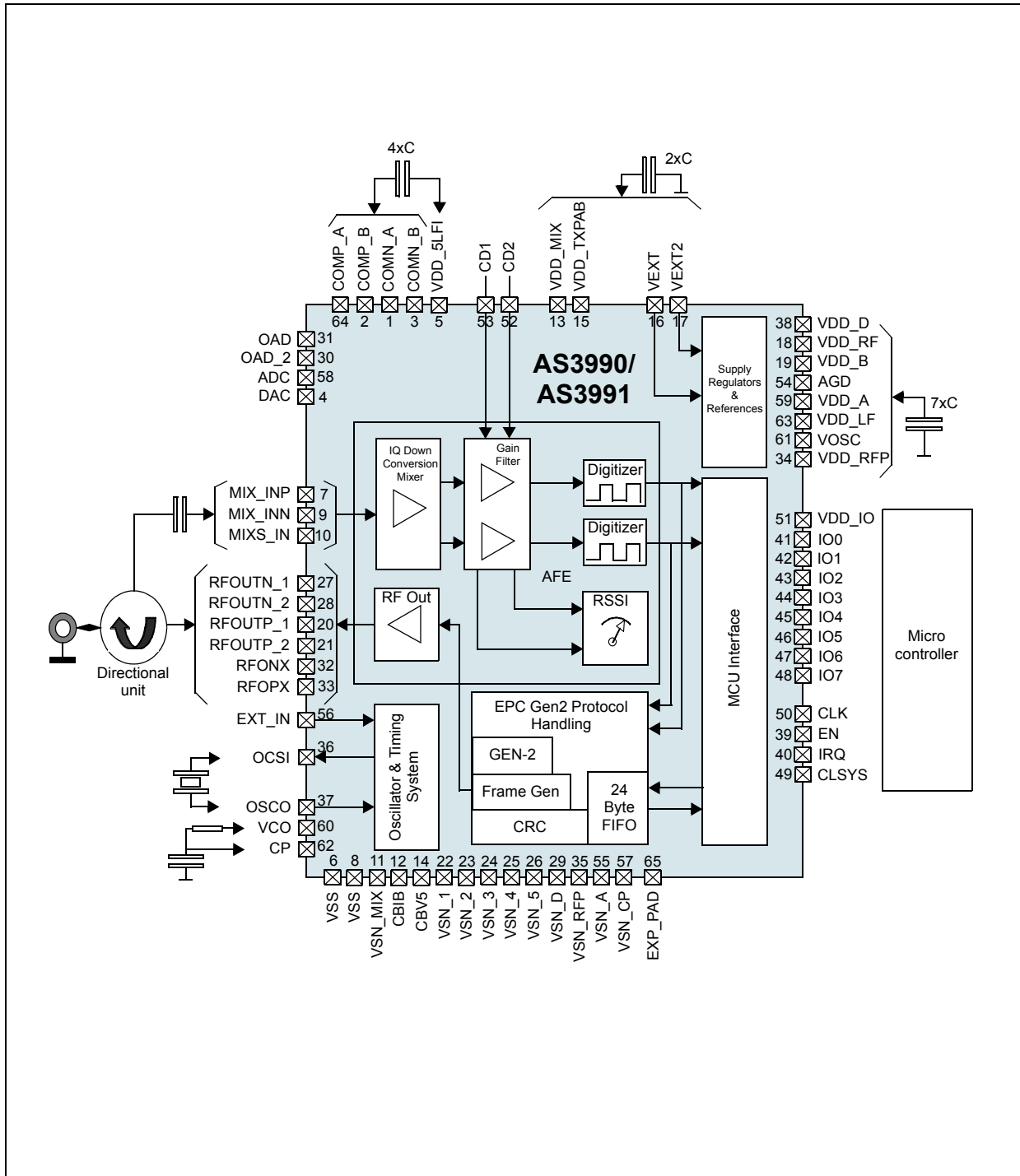

Copyrights

Copyright © 1997-2008, austriamicrosystems AG, Schloss Premstaetten, 8141 Unterpemstaetten, Austria-Europe. Trademarks Registered ®. All rights reserved. The material herein may not be reproduced, adapted, merged, translated, stored, or used without the prior written consent of the copyright owner.

All products and companies mentioned are trademarks or registered trademarks of their respective companies.

Disclaimer

Devices sold by austriamicrosystems AG are covered by the warranty and patent indemnification provisions appearing in its Term of Sale. austriamicrosystems AG makes no warranty, express, statutory, implied, or by description regarding the information set forth herein or regarding the freedom of the described devices from patent infringement. austriamicrosystems AG reserves the right to change specifications and prices at any time and without notice. Therefore, prior to designing this product into a system, it is necessary to check with austriamicrosystems AG for current information. This product is intended for use in normal commercial applications. Applications requiring extended temperature range, unusual environmental requirements, or high reliability applications, such as military, medical life-support or life-sustaining equipment are specifically not recommended without additional processing by austriamicrosystems AG for each application. For shipments of less than 100 parts the manufacturing flow might show deviations from the standard production flow, such as test flow or test location.

The information furnished here by austriamicrosystems AG is believed to be correct and accurate. However, austriamicrosystems AG shall not be liable to recipient or any third party for any damages, including but not limited to personal injury, property damage, loss of profits, loss of use, interruption of business or indirect, special, incidental or consequential damages, of any kind, in connection with or arising out of the furnishing, performance or use of the technical data herein. No obligation or liability to recipient or any third party shall arise or flow out of austriamicrosystems AG rendering of technical or other services.



Contact Information

Headquarters

austriamicrosystems AG
A-8141 Schloss Premstaetten, Austria

Tel: +43 (0) 3136 500 0
Fax: +43 (0) 3136 525 01

For Sales Offices, Distributors and Representatives, please visit:

<http://www.austriamicrosystems.com/contact>