

## FEATURES

- Frequency Range: 800MHz to 1.5GHz
- High IIP3: 21.5dBm at 900MHz
- High IIP2: 52dBm
- Noise Figure: 12.8dB at 900MHz
- Conversion Gain: 4.3dB at 900MHz
- I/Q Gain Mismatch: 0.2dB
- Shutdown Mode
- 16-Lead QFN 4mm × 4mm Package with Exposed Pad

## APPLICATIONS

- Cellular/PCS/UMTS Infrastructure
- High Linearity Direct Conversion I/Q Receiver
- High Linearity I/Q Demodulator

## DESCRIPTION

The LT<sup>®</sup>5516 is an 800MHz to 1.5GHz direct conversion quadrature demodulator optimized for high linearity receiver applications. It is suitable for communications receivers where an RF or IF signal is directly converted into I and Q baseband signals with bandwidth up to 260MHz. The LT5516 incorporates balanced I and Q mixers, LO buffer amplifiers and a precision, high frequency quadrature generator.

In an RF receiver, the high linearity of the LT5516 provides excellent spur-free dynamic range, even with fixed gain front end amplification. This direct conversion receiver can eliminate the need for intermediate frequency (IF) signal processing, as well as the corresponding requirements for image filtering and IF filtering. Channel filtering can be performed directly at the outputs of the I and Q channels. These outputs can interface directly to channel-select filters (LPFs) or to a baseband amplifier.

LT, LTC and LTM are registered trademarks of Linear Technology Corporation. All other trademarks are the property of their respective owners.

## TYPICAL APPLICATION

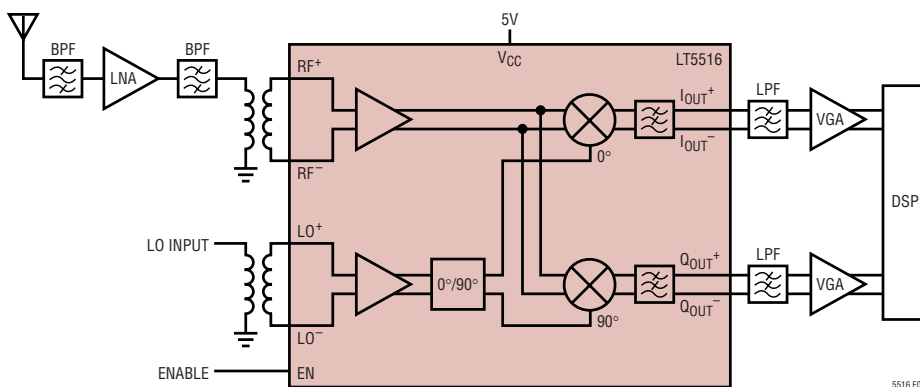
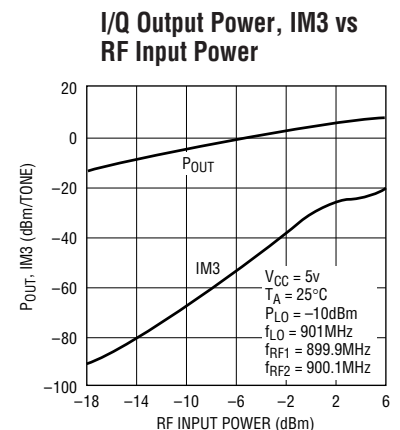

Figure 1. High Signal-Level I/Q Demodulator for Wireless Infrastructure



## ABSOLUTE MAXIMUM RATINGS

(Note 1)

Power Supply Voltage .....	5.5V
Enable Voltage .....	0, $V_{CC}$
LO <sup>+</sup> to LO <sup>-</sup> Differential Voltage .....	$\pm 2V$ (+10dBm Equivalent)
RF <sup>+</sup> to RF <sup>-</sup> Differential Voltage .....	$\pm 2V$ (+10dBm Equivalent)
Operating Ambient Temperature .....	-40°C to 85°C
Storage Temperature Range .....	-65°C to 125°C
Maximum Junction Temperature .....	125°C

## PACKAGE/ORDER INFORMATION

<p>TOP VIEW</p> <p>UF PACKAGE 16-LEAD (4mm × 4mm) PLASTIC QFN</p> <p>EXPOSED PAD (PIN 17) IS GROUND (MUST BE SOLDERED TO PCB)</p> <p><math>T_{JMAX} = 125^{\circ}C</math>, <math>\theta_{JA} = 38^{\circ}C/W</math></p>	ORDER PART NUMBER
	LT5516EUF
	UF PART MARKING
	5516
<p><b>Order Options</b> Tape and Reel: Add #TR          Lead Free: Add #PBF Lead Free Tape and Reel: Add #TRPBF          Lead Free Part Marking: <a href="http://www.linear.com/leadfree/">http://www.linear.com/leadfree/</a></p>	

Consult LTC Marketing for parts specified with wider operating temperature ranges.

## AC ELECTRICAL CHARACTERISTICS

$T_A = 25^{\circ}C$ ,  $V_{CC} = 5V$ , EN = high,  $f_{RF1} = 899.9MHz$ ,  $f_{RF2} = 900.1MHz$ ,  $f_{LO} = 901MHz$ ,  $P_{LO} = -10dBm$  unless otherwise noted. (Notes 2, 3) (Test circuit shown in Figure 2)

PARAMETER	CONDITIONS	MIN	TYP	MAX	UNITS
Frequency Range			0.8 to 1.5		GHz
LO Power			-13 to -2		dBm
Conversion Gain	Voltage Gain, Load Impedance = 1k	2	4.3		dB
Conversion Gain Variation vs Temperature	-40°C to 85°C		0.01		dB/°C
Noise Figure	R1 = 8.2Ω R1 = 3.3Ω, $P_{LO} = -5dBm$		11.4		dB
			12.8		dB
Input 3rd Order Intercept	2-Tone, -10dBm/Tone, $\Delta f = 200kHz$	R1 = 8.2Ω R1 = 3.3Ω, $P_{LO} = -5dBm$		17.0	dBm
				21.5	dBm
Input 2nd Order Intercept	Input = -10dBm	R1 = 8.2Ω R1 = 3.3Ω, $P_{LO} = -5dBm$		46.0	dBm
				52.0	dBm
Input 1dB Compression	R1 = 8.2Ω		6.6		dBm
Baseband Bandwidth			260		MHz
I/Q Gain Mismatch	(Note 4)		0.2	0.7	dB
I/Q Phase Mismatch	(Note 4)		1		degree
Output Impedance	Differential		120		Ω
LO to RF Leakage			-65		dBm
RF to LO Isolation			57		dB

## DC ELECTRICAL CHARACTERISTICS $T_A = 25^\circ\text{C}$ . $V_{CC} = 5\text{V}$ unless otherwise noted.

PARAMETER	CONDITIONS	MIN	TYP	MAX	UNITS
Supply Voltage		4		5.25	V
Supply Current		80	117	150	mA
Shutdown Current	EN = Low			20	$\mu\text{A}$
Turn-On Time			120		ns
Turn-Off Time			650		ns
EN = High (On)		1.6			V
EN = Low (Off)				1.3	V
EN Input Current	$V_{\text{ENABLE}} = 5\text{V}$		2		$\mu\text{A}$
Output DC Offset Voltage ( $ I_{\text{OUT}^+} - I_{\text{OUT}^-} $ , $ Q_{\text{OUT}^+} - Q_{\text{OUT}^-} $ )	$f_{\text{LO}} = 901\text{MHz}$ , $P_{\text{LO}} = -10\text{dBm}$		1	25	mV
Output DC Offset Variation vs Temperature	$-40^\circ\text{C}$ to $85^\circ\text{C}$		20		$\mu\text{V}/^\circ\text{C}$

**Note 1:** Stresses beyond those listed under Absolute Maximum Ratings may cause permanent damage to the device. Exposure to any Absolute Maximum Rating condition for extended periods may affect device reliability and lifetime.

**Note 2:** Tests are performed as shown in the configuration of Figure 2 with  $R_1 = 8.2\Omega$ , unless otherwise noted.

**Note 3:** Specifications over the  $-40^\circ\text{C}$  to  $85^\circ\text{C}$  temperature range are assured by design, characterization and correlation with statistical process control.

**Note 4:** Measured at  $P_{\text{RF}} = -10\text{dBm}$  and output frequency = 1MHz.

# TYPICAL PERFORMANCE CHARACTERISTICS

(Test circuit optimized for 900MHz operation as shown in Figure 2)

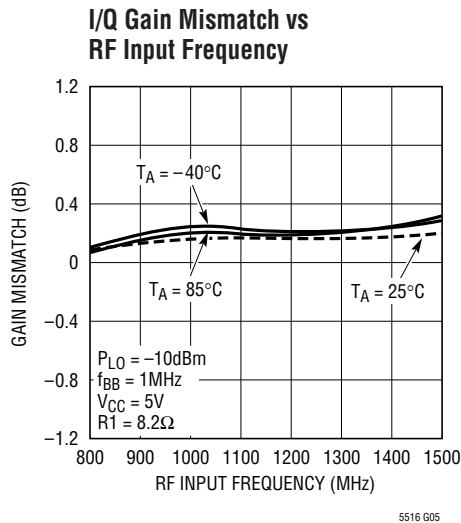
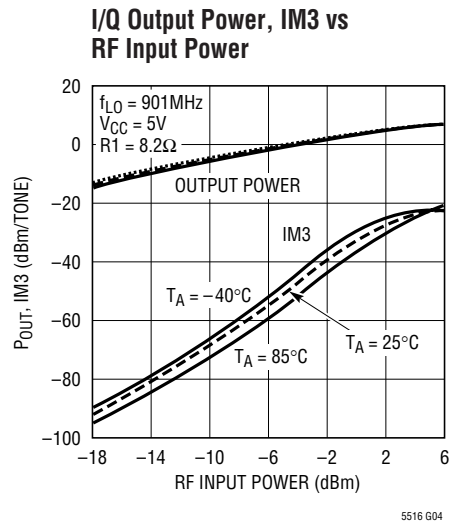
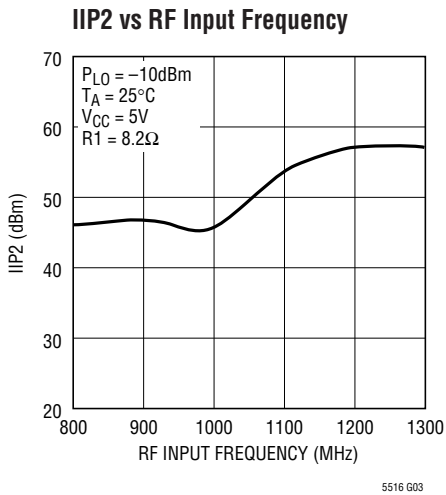
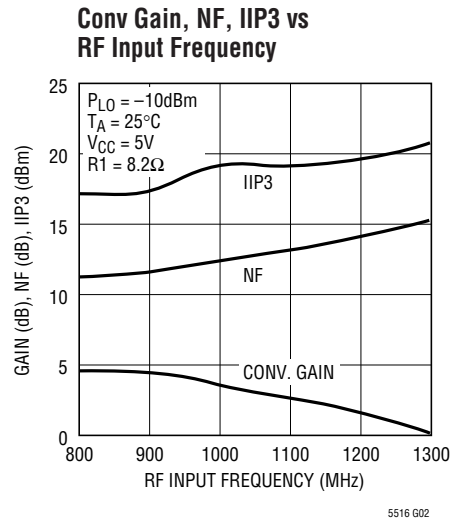
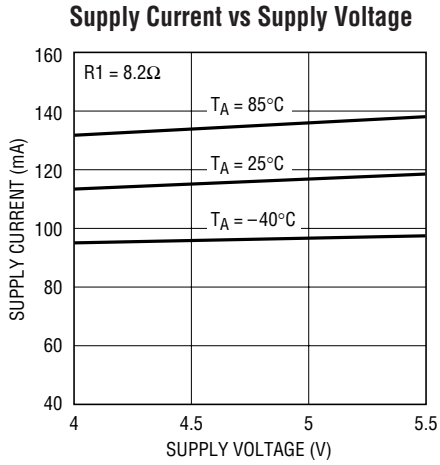

# TYPICAL PERFORMANCE CHARACTERISTICS

(Test circuit optimized for 900MHz operation as shown in Figure 2)

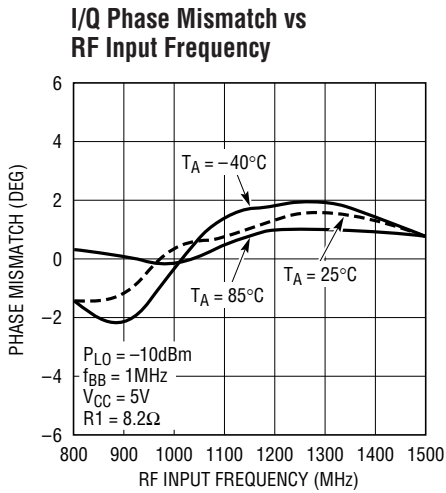

5516 G06

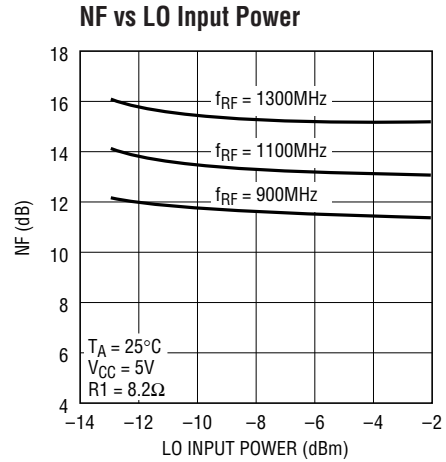

5516 G07

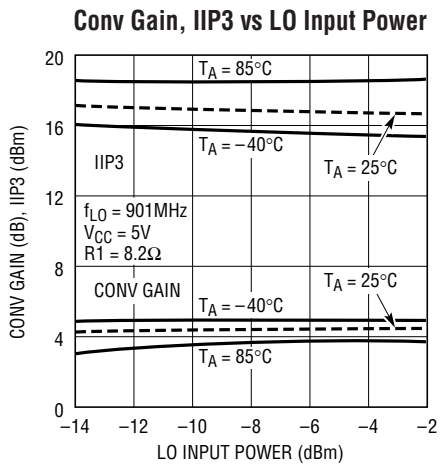

5516 G08

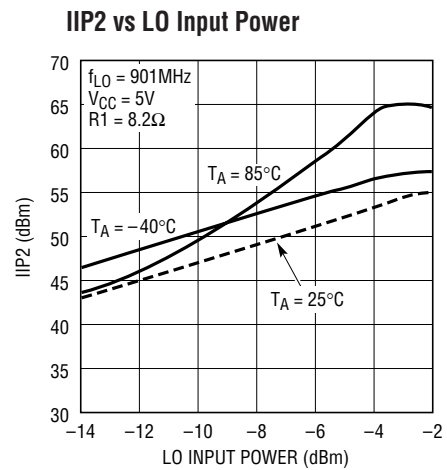

5516 G09

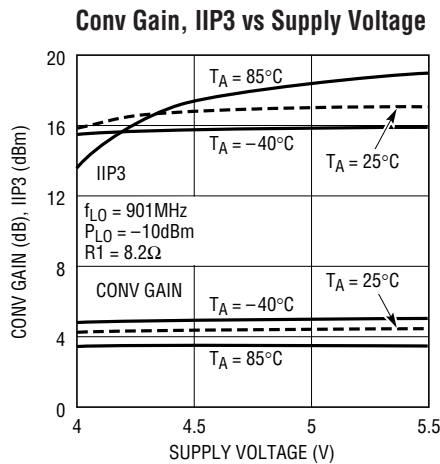

5516 G10

# TYPICAL PERFORMANCE CHARACTERISTICS

(Test circuit optimized for 900MHz operation as shown in Figure 2)

**LO-RF Leakage vs LO Input Power**

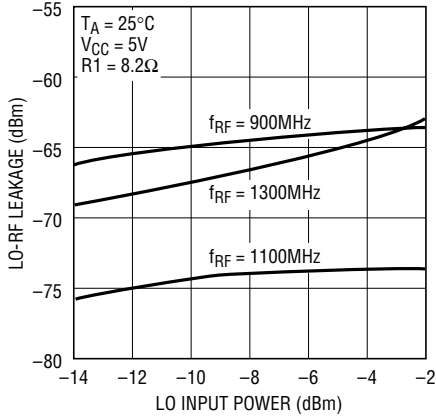

5516 G11

**RF-LO Isolation vs RF Input Power**

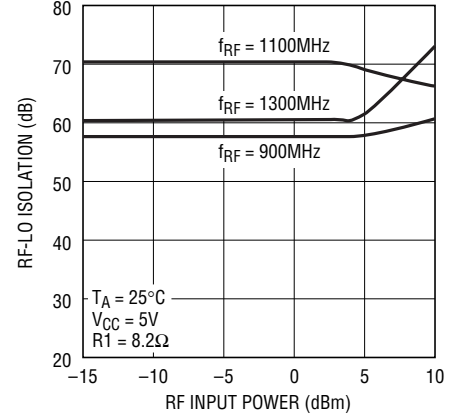

5516 G12

**RF, LO Port Return Loss vs Frequency**

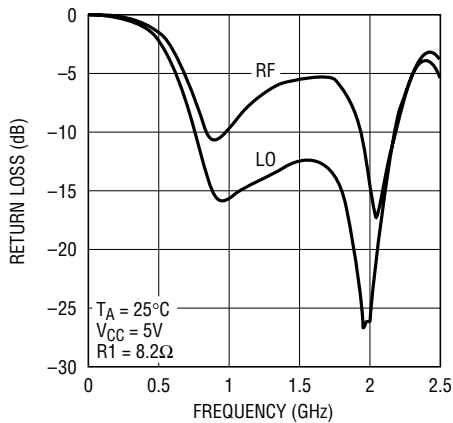

5516 G13

**Conv Gain vs Baseband Frequency**

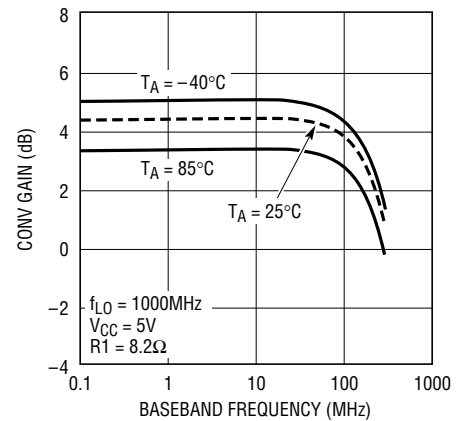

5516 G14

**Conv Gain, NF, IIP3 vs R1**

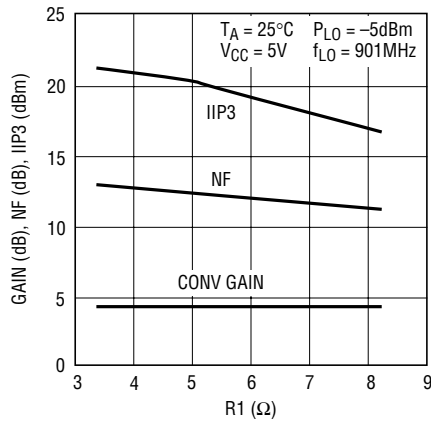

5516 G15

**Supply Current, IIP2 vs R1**

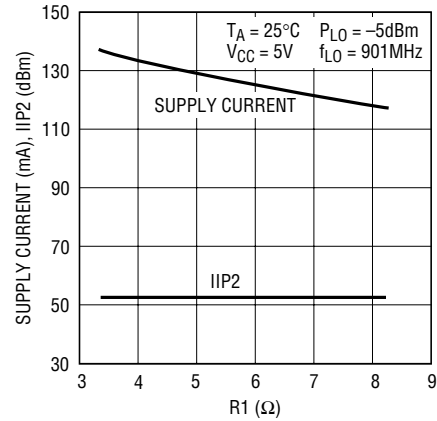

5516 G16

## PIN FUNCTIONS

**GND (Pins 1, 4):** Ground Pin.

**RF<sup>+</sup>, RF<sup>-</sup> (Pins 2, 3):** Differential RF Input Pins. These pins are internally biased to 1.54V. They must be driven with a differential signal. An external matching network is required for impedance transformation.

**V<sub>CC</sub> (Pins 5, 8, 9, 12):** Power Supply Pins. These pins should be decoupled using 1000pF and 0.1μF capacitors.

**V<sub>CM</sub> (Pin 6):** Common Mode and DC Return for the I-Mixer and Q-Mixer. An external resistor must be connected between this pin and ground to set the dc bias current of the I/Q demodulator.

**EN (Pin 7):** Enable Pin. When the input voltage is higher than 1.6V, the circuit is completely turned on. When the input voltage is less than 1.3V, the circuit is turned off.

**LO<sup>+</sup>, LO<sup>-</sup> (Pins 10, 11):** Differential Local Oscillator Input Pins. These pins are internally biased to 2.44V. They can be driven single-ended by connecting one to an AC ground through a 1000pF capacitor. However, differential input drive is recommended to minimize LO feedthrough to the RF input pins.

**Q<sub>OUT</sub><sup>-</sup>, Q<sub>OUT</sub><sup>+</sup> (Pins 13, 14):** Differential Baseband Output Pins of the Q-Channel. The internal DC bias voltage is V<sub>CC</sub> - 0.68V for each pin.

**I<sub>OUT</sub><sup>-</sup>, I<sub>OUT</sub><sup>+</sup> (Pins 15, 16):** Differential Baseband Output Pins of the I-Channel. The internal DC bias voltage is V<sub>CC</sub> - 0.68V for each pin.

**GROUND (Pin 17, Backside Contact):** Ground Return for the Entire IC. This pin must be soldered to the printed circuit board ground plane.

## BLOCK DIAGRAM

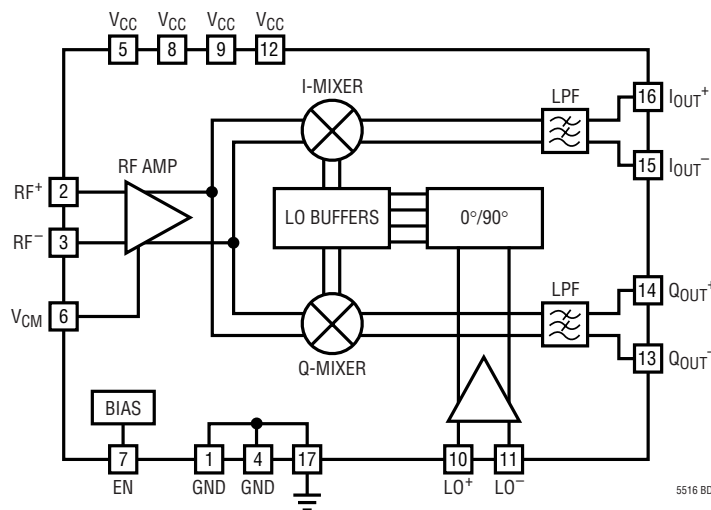

TEST CIRCUITS

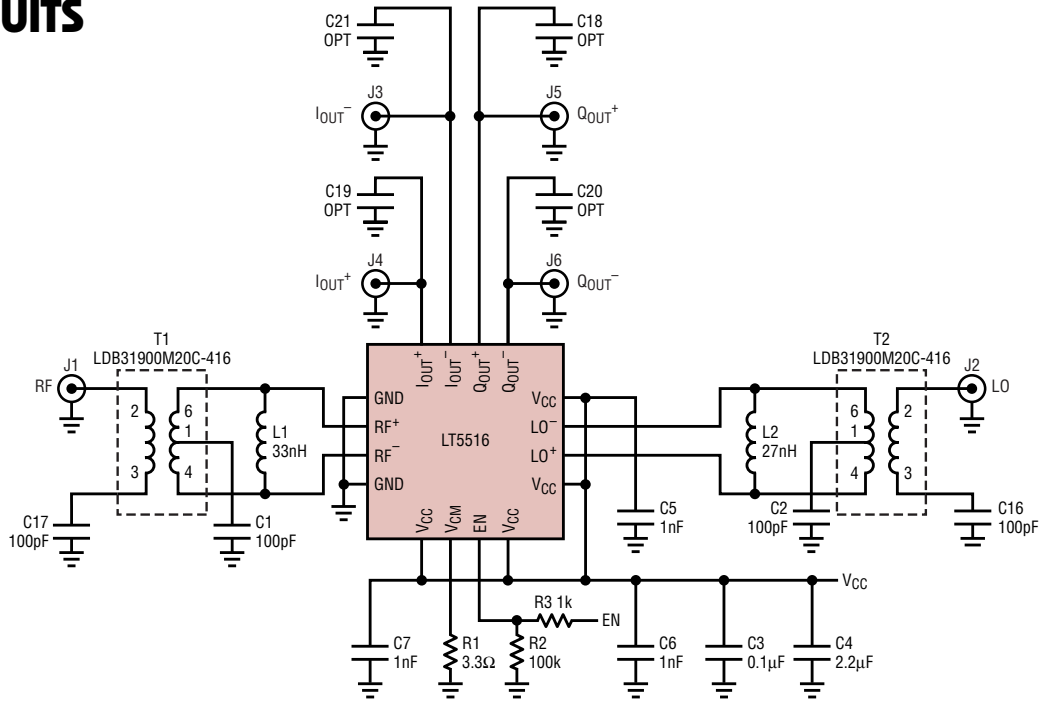

REFERENCE DESIGNATION	VALUE	SIZE	PART NUMBER
C1, C2, C16, C17	100pF	0402	AVX 04025C101JAT
C5, C6, C7	1nF	0402	AVX 04025C102JAT
C3	0.1μF	0402	AVX 0402ZD104KAT
C4	2.2μF	3216	AVX TPSA225M010R1800
L1	33nH	0402	Murata LQP10A
L2	27nH	0402	Murata LQP10A
R1	3.3Ω	0402	
R2	100k	0402	
R3	1k	0402	
T1, T2	1:4		Murata LDB31900M20C-416

5516 F02

Figure 2. 900MHz Evaluation Circuit Schematic

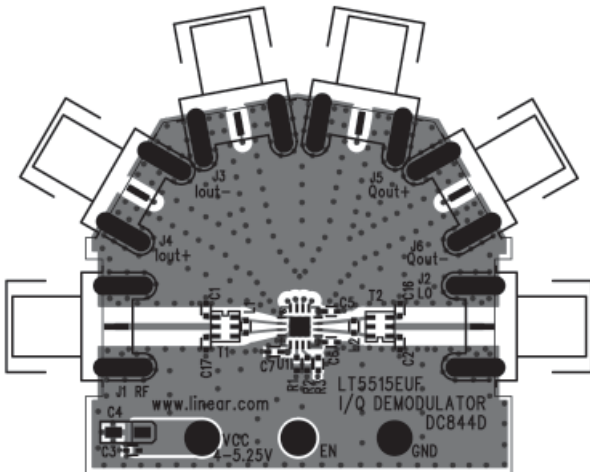

Figure 3. Topside of Evaluation Board

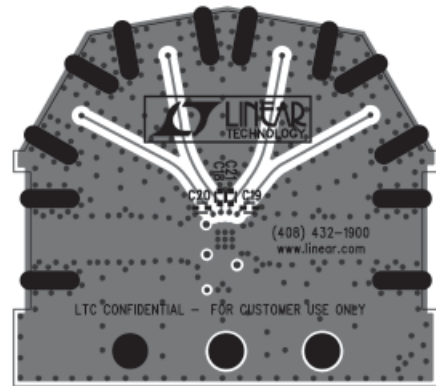

Figure 4. Bottom Side of Evaluation Board

5516fa



## APPLICATIONS INFORMATION

The LT5516 is a direct I/Q demodulator targeting high linearity receiver applications, including wireless infrastructure. It consists of an RF amplifier, I/Q mixers, a quadrature LO carrier generator and bias circuitry.

The RF signal is applied to the inputs of the RF amplifier and is then demodulated into I/Q baseband signals using quadrature LO signals. The quadrature LO signals are internally generated by precision 90° phase shifters. The demodulated I/Q signals are lowpass filtered internally with a –3dB bandwidth of 265MHz. The differential outputs of the I-channel and Q-channel are well matched in amplitude; their phases are 90° apart.

### RF Input Port

Differential drive is highly recommended for the RF inputs to minimize the LO feedthrough to the RF port and to maximize gain. (See Figure 2.) A 1:4 transformer is used on the demonstration board for wider bandwidth matching. To assure good NF and maximize the demodulator gain, a low loss transformer is employed. Shunt inductor L1, with high resonance frequency, is required for proper impedance matching. Single-ended to differential conversion can also be implemented using narrow band, discrete L-C circuits to produce the required balanced waveforms at the RF<sup>+</sup> and RF<sup>-</sup> inputs. The differential impedance of the RF inputs is listed in Table 1.

**Table 1. RF Input Differential Impedance**

FREQUENCY (MHz)	DIFFERENTIAL INPUT IMPEDANCE (Ω)	DIFFERENTIAL S11	
		MAG	ANGLE (°)
800	169.7-j195.2	0.779	-16.9
900	156.1-j181.8	0.766	-18.3
1000	145.6-j170.0	0.753	-19.6
1100	137.3-j160.0	0.740	-20.9
1200	130.7-j152.1	0.729	-21.9
1300	124.9-j144.7	0.718	-23.0
1400	119.9-j138.3	0.707	-24.0
1500	115.7-j133.1	0.698	-24.9

The RF<sup>+</sup> and RF<sup>-</sup> inputs (Pins 2, 3) are internally biased at 2.44V. These two pins should be DC blocked when connected to ground or other matching components. The RF input equivalent circuit is shown in Figure 5.

An external resistor (R1) is connected to Pin 6 (V<sub>CM</sub>) to set the optimum DC current for I/Q mixer linearity. The IIP3 can be improved with a smaller R1 at a price of slightly higher NF and I<sub>CC</sub>. The RF performances of NF, IIP3 and IIP2 vs R1 are shown in the Typical Performance Characteristics.

### LO Input Port

The LO inputs (Pins 10,11) should be driven differentially to minimize LO feedthrough to the RF port. This can be accomplished by means of a single-ended to differential conversion as shown in Figure 2. L4, the 27nH shunt inductor, serves to tune out the capacitive component of the LO differential input. The resonance frequency of the inductor should be greater than the operating frequency. A 1:4 transformer is used on the demo board to match the 200Ω on-chip resistance to a 50Ω source. Figure 6 shows the LO input equivalent circuit and the associated matching network.

Single-ended to differential conversion at the LO inputs can also be implemented using a discrete L-C circuit to produce a balanced waveform without a transformer.

An alternative solution is a simple single-ended termination. However, the LO feedthrough to RF may be degraded. Either LO<sup>+</sup> or LO<sup>-</sup> input can be terminated to a 50Ω source with a matching circuit, while the other input is connected to ground through a 100pF bypass capacitor.

Table 2 shows the differential input impedance of the LO input port.

**Table 2. LO Input Differential Impedance**

FREQUENCY (MHz)	DIFFERENTIAL INPUT IMPEDANCE (Ω)	DIFFERENTIAL S11	
		MAG	ANGLE (°)
800	118.4-j65.1	0.552	-22.5
900	110.1-j66.7	0.517	-25.4
1000	102.2-j67.5	0.512	-28.5
1100	94.6-j67.2	0.505	-31.8
1200	87.5-j66.1	0.498	-35.0
1300	80.8-j64.4	0.490	-38.3
1400	74.7-j62.1	0.480	-42.0
1500	69.3-j59.4	0.469	-45.8

## APPLICATIONS INFORMATION

### I-Channel and Q-Channel Outputs

Each of the I-channel and Q-channel outputs is internally connected to  $V_{CC}$  through a  $60\Omega$  resistor. The output dc bias voltage is  $V_{CC} - 0.68V$ . The outputs can be DC coupled or AC coupled to the external loads. The differential output impedance of the demodulator is  $120\Omega$  in parallel with a  $5pF$  internal capacitor, forming a lowpass filter with a  $-3dB$  corner frequency at  $265MHz$ .  $R_{LOAD}$  (the single-ended load resistance) should be larger than  $600\Omega$  to assure full gain. The gain is reduced by  $20 \cdot \log(1 + 120\Omega/R_{LOAD})$  in dB when the differential output is terminated by  $R_{LOAD}$ . For instance, the gain is reduced by  $6.85dB$  when each output pin is connected to a  $50\Omega$  load ( $100\Omega$  differential load). The output should be taken differentially (or by using differential-to-single-ended conversion) for best RF performance, including NF and IM2.

The phase relationship between the I-channel output signal and Q-channel output signal is fixed. When the LO input frequency is larger (or smaller) than the RF input frequency, the Q-channel outputs ( $Q_{OUT+}$ ,  $Q_{OUT-}$ ) lead (or lag) I-channel outputs ( $I_{OUT+}$ ,  $I_{OUT-}$ ) by  $90^\circ$ .

When AC output coupling is used, the resulting highpass filter's  $-3dB$  roll-off frequency is defined by the R-C constant of the blocking capacitor and  $R_{LOAD}$ , assuming  $R_{LOAD} > 600\Omega$ .

Care should be taken when the demodulator's outputs are DC coupled to the external load, to make sure that the I/Q mixers are biased properly. If the current drain from the outputs exceeds  $6mA$ , there can be significant degradation of the linearity performance. Each output can sink no more than  $13mA$  when the outputs are connected to an external load with a DC voltage higher than  $V_{CC} - 0.68V$ . The I/Q output equivalent circuit is shown in Figure 7.

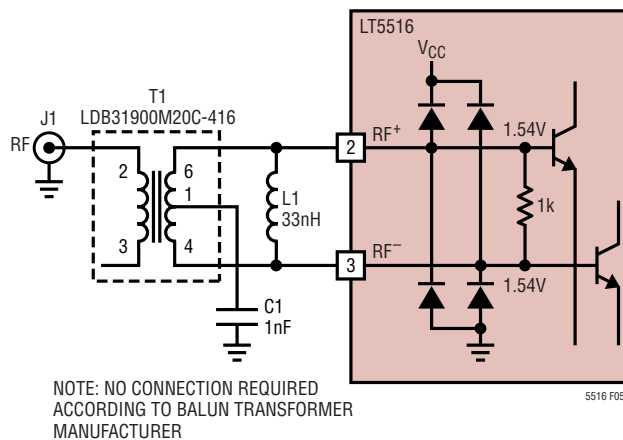

Figure 5. RF Input Equivalent Circuit with External Matching

## APPLICATIONS INFORMATION

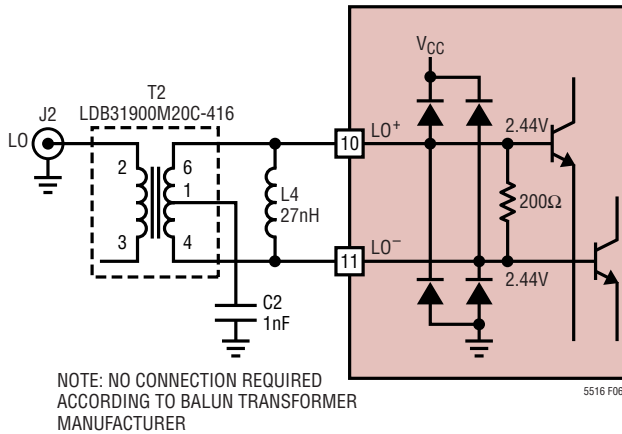

Figure 6. LO Input Equivalent Circuit with External Matching

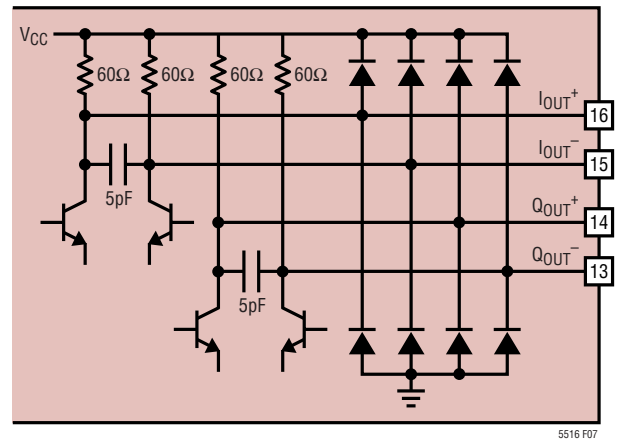
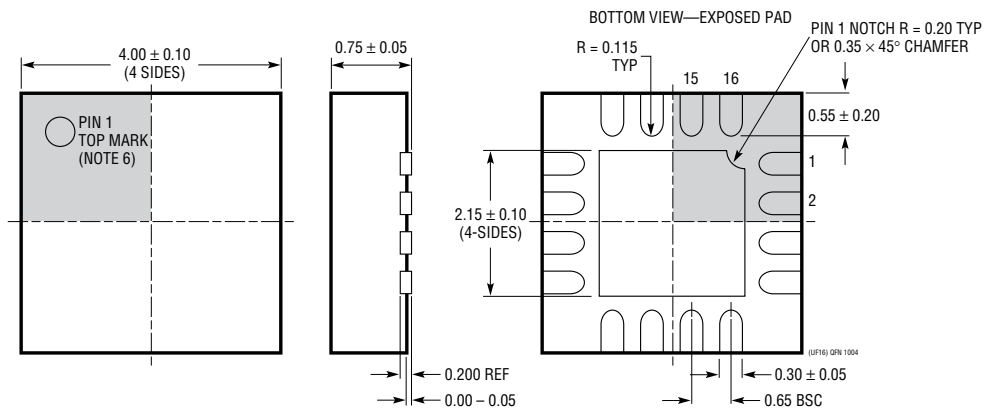
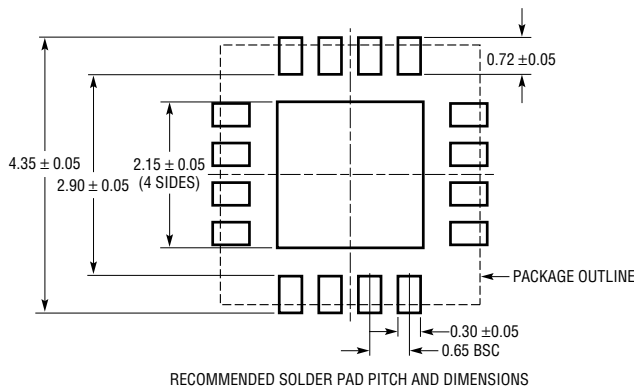

Figure 7. I/Q Output Equivalent Circuit

## PACKAGE DESCRIPTION

UF Package  
16-Lead Plastic QFN (4mm × 4mm)  
(Reference LTC DWG # 05-08-1692)



- NOTE:
1. DRAWING CONFORMS TO JEDEC PACKAGE OUTLINE MO-220 VARIATION (WGCG)
  2. DRAWING NOT TO SCALE
  3. ALL DIMENSIONS ARE IN MILLIMETERS
  4. DIMENSIONS OF EXPOSED PAD ON BOTTOM OF PACKAGE DO NOT INCLUDE MOLD FLASH. MOLD FLASH, IF PRESENT, SHALL NOT EXCEED 0.15mm ON ANY SIDE

5. EXPOSED PAD SHALL BE SOLDER PLATED
6. SHADED AREA IS ONLY A REFERENCE FOR PIN 1 LOCATION ON THE TOP AND BOTTOM OF PACKAGE

## RELATED PARTS

PART NUMBER	DESCRIPTION	COMMENTS
<b>RF Power Controllers</b>		
LTC1757A	RF Power Controller	Multiband GSM/DCS/GPRS Mobile Phones
LTC1758	RF Power Controller	Multiband GSM/DCS/GPRS Mobile Phones
LTC1957	RF Power Controller	Multiband GSM/DCS/GPRS Mobile Phones
LTC4400	SOT-23 RF PA Controller	Multiband GSM/DCS/GPRS Phones, 45dB Dynamic Range, 450kHz Loop BW
LTC4401	SOT-23 RF PA Controller	Multiband GSM/DCS/GPRS Phones, 45dB Dynamic Range, 250kHz Loop BW
LTC4403	RF Power Controller for EDGE/TDMA	Multiband GSM/GPRS/EDGE Mobile Phones
LT5500	RF Front End	Dual LNA gain Setting +13.5dB/-14dB at 2.5GHz, Double-Balanced Mixer, $1.8V \leq V_{SUPPLY} \leq 5.25V$
LT5502	400MHz Quadrature Demodulator with RSSI	1.8V to 5.25V Supply, 70MHz to 400MHz IF, 84dB Limiting Gain, 90dB RSSI Range
LT5503	1.2GHz to 2.7GHz Direct IQ Modulator and Up Converting Mixer	1.8V to 5.25V Supply, Four-Step RF Power Control, 120MHz Modulation Bandwidth
LT5504	800MHz to 2.7GHz RF Measuring Receiver	80dB Dynamic Range, Temperature Compensated, 2.7V to 5.5V Supply
LTC5505	300MHz to 3.5GHz RF Power Detector	>40dB Dynamic Range, Temperature Compensated, 2.7V to 6V Supply
LT5506	500MHz Quadrature IF Demodulator with VGA	1.8V to 5.25V Supply, 40MHz to 500MHz IF, -4dB to 57dB Linear Power Gain
LTC5507	100kHz to 1GHz RF Power Detector	48dB Dynamic Range, Temperature Compensated, 2.7V to 6V Supply
LTC5508	300MHz to 7GHz RF Power Detector	SC70 Package
LTC5509	300MHz to 3GHz RF Power Detector	36dB Dynamic Range, SC70 Package
LT5511	High Signal Level Up Converting Mixer	RF Output to 3GHz, 17dBm IIP3, Integrated LO Buffer
LT5512	High Signal Level Down Converting Mixer	DC-3GHz, 20dBm IIP3, Integrated LO Buffer