

SI-8200L/8300L Series

Switching Type — Self Oscillation Type with Coil

Features

- Integrated switching IC and coil construction
- Requires 2 external components only
- Low switching noise
- Heatsink not required

Applications

- For power supplies in telephone sets
- For power supplies in office equipment

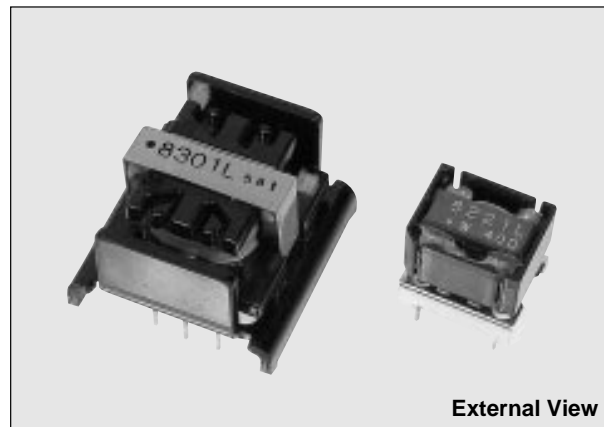

Lineup

8200L Series

Type No.	V _o	I _o
SI-8201L	5V	0.4A
SI-8202L	6V	0.35A
SI-8203L	12V	0.35A
SI-8204L	5.2V	0.4A
SI-8221L	5V	0.4A

8200L Series (high-VIN type)

Type No.	V _o	I _o
SI-8211L	5V	0.3A
SI-8213L	12V	0.28A

8300L Series

Type No.	V _o	I _o
SI-8301L	5V	1A
SI-8303L	5.4V	1A

Absolute Maximum Ratings

Parameter	Symbol	Ratings									Unit
		8200L Series							8300L Series		
		SI-8201L	SI-8202L	SI-8203L	SI-8204L	SI-8221L	SI-8211L	SI-8213L	SI-8301L	SI-8303L	
DC Input Voltage	V _{IN}	45				40	60		45		V
Storage Temperature	T _{stg}	-25 to +85									°C

Recommended Operating Conditions

Parameter	Symbol	Ratings									Unit
		8200L Series							8300L Series		
		SI-8201L	SI-8202L	SI-8203L	SI-8204L	SI-8221L	SI-8211L	SI-8213L	SI-8301L	SI-8303L	
DC Input Voltage Range	V _{IN}	10 to 40	11 to 40	16 to 40	10 to 40	8 to 35	15 to 55	22 to 55	8 to 40	8.5 to 40	V
Output Current Range	I _o	0 to 0.4	0 to 0.35		0 to 0.4		0 to 0.3	0 to 0.28	0 to 1		A
Operating Temperature Range	T _{op}	-10 to +65							-20 to +85		°C

SI-8200L/8300L Series

■ Electrical Characteristics (Ta=25°C)

Parameter	Symbol	Ratings															Unit
		SI-8200L Series															
		SI-8201L			SI-8202L			SI-8203L			SI-8204L			SI-8221L			
	min	typ	max	min	typ	max	min	typ	max	min	typ	max	min	typ	max		
Output Voltage	V _O	4.9	5.0	5.1	5.9	6.0	6.1	11.8	12.0	12.2	5.1	5.2	5.3	4.85	5.00	5.15	V
	Condition	V _{IN} =15V, I _O =0.2A			V _{IN} =20V, I _O =0.2A			V _{IN} =25V, I _O =0.2A			V _{IN} =15V, I _O =0.2A			V _{IN} =15V, I _O =0.2A			
Efficiency	η		73			74			79			73		76	80		%
	Condition	V _{IN} =15V, I _O =0.2A			V _{IN} =20V, I _O =0.2A			V _{IN} =25V, I _O =0.2A			V _{IN} =15V, I _O =0.2A			V _{IN} =15V, I _O =0.2A			
Switching Frequency	f	25			25			25			25			25			kHz
Line Regulation	ΔV _{OLINE}		15	60		15	60		15	60		15	60		5	15	mV
	Condition	V _{IN} =10 to 20V, I _O =0.2A			V _{IN} =11 to 29V, I _O =0.2A			V _{IN} =16 to 34V, I _O =0.2A			V _{IN} =10 to 20V, I _O =0.2A			V _{IN} =10 to 20V, I _O =0.2A			
Load Regulation	ΔV _{OLOAD}		15	60		15	60		60	100		15	60		15	60	mV
	Condition	V _{IN} =15V, I _O =0.02 to 0.25A			V _{IN} =20V, I _O =0.02 to 0.3A			V _{IN} =25V, I _O =0.02 to 0.35A			V _{IN} =15V, I _O =0.02 to 0.25A			V _{IN} =15V, I _O =0.02 to 0.25A			
Temperature Coefficient of Output Voltage	ΔV _O /ΔT			±1.5			±1.5			±1.5			±1.5		±0.5	±1.5	mV/°C
Switching Ripple Voltage (C ₂ =470μF)	ΔV _r		30	60		30			60	100		30			30	60	mVp-p
	Condition	V _{IN} =25V, I _O =0.3A			V _{IN} =25V, I _O =0.3A			V _{IN} =40V, I _O =0.35A			V _{IN} =25V, I _O =0.3A			V _{IN} =25V, I _O =0.3A			

Parameter	Symbol	Ratings												Unit
		SI-8200L Series (high-V _{IN} type)						SI-8300L Series						
		SI-8211L			SI-8213L			SI-8301L			SI-8303L			
	min	typ	max	min	typ	max	min	typ	max	min	typ	max		
Output Voltage	V _O	4.9	5.0	5.1	11.8	12.0	12.2	5.0	5.1	5.2	5.3	5.4	5.5	V
	Condition	V _{IN} =35V, I _O =0.2A			V _{IN} =38V, I _O =0.2A			V _{IN} =15V, I _O =0.5A			V _{IN} =15V, I _O =0.5A			
Efficiency	η		63			78			73			73		%
	Condition	V _{IN} =35V, I _O =0.2A			V _{IN} =38V, I _O =0.2A			V _{IN} =15V, I _O =0.5A			V _{IN} =15V, I _O =0.5A			
Switching Frequency	f	25			25				25			25		kHz
Line Regulation	ΔV _{OLINE}			60			60			50			50	mV
	Condition	V _{IN} =20 to 50V, I _O =0.2A			V _{IN} =22 to 50V, I _O =0.2A			V _{IN} =10 to 20V, I _O =0.5A			V _{IN} =10 to 20V, I _O =0.5A			
Load Regulation	ΔV _{OLOAD}			60			60			80			80	mV
	Condition	V _{IN} =35V, I _O =0.02 to 0.3A			V _{IN} =38V, I _O =0.02 to 0.28A			V _{IN} =15V, I _O =0.3 to 0.7A			V _{IN} =15V, I _O =0.3 to 0.7A			
Temperature Coefficient of Output Voltage	ΔV _O /ΔT			±1.5			±1.5			±1.5			±1.5	mV/°C
Switching Ripple Voltage (C ₂ =470μF)	ΔV _r		30	60		50	100		45			45		mVp-p
	Condition	V _{IN} =48V, I _O =0.3A			V _{IN} =48V, I _O =0.28A			V _{IN} =15V, I _O =0.5A			V _{IN} =15V, I _O =0.5A			

■ Outline Drawing (unit: mm)

SI-8201L•8202L•8203L•8204L

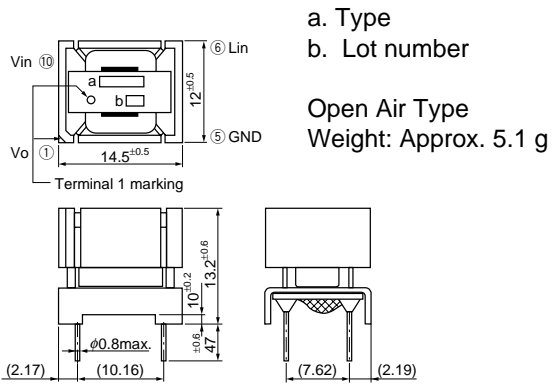

SI-8221L

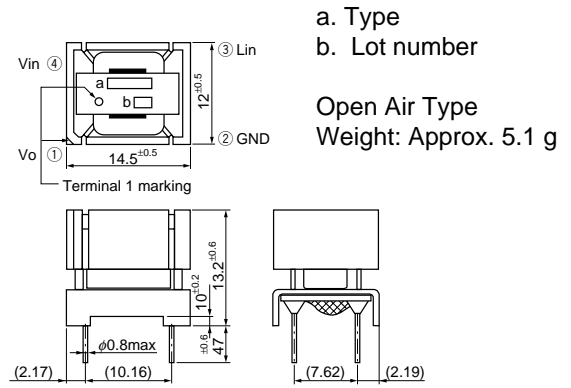

SI-8211L•8213L

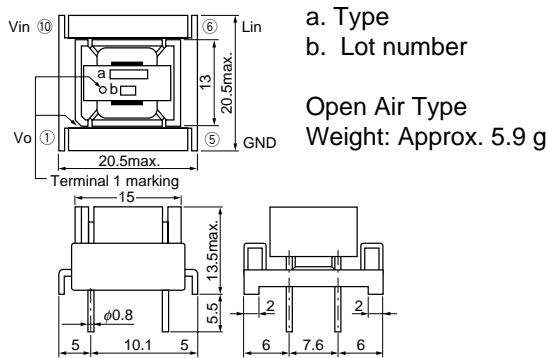

SI-8301L•8303L

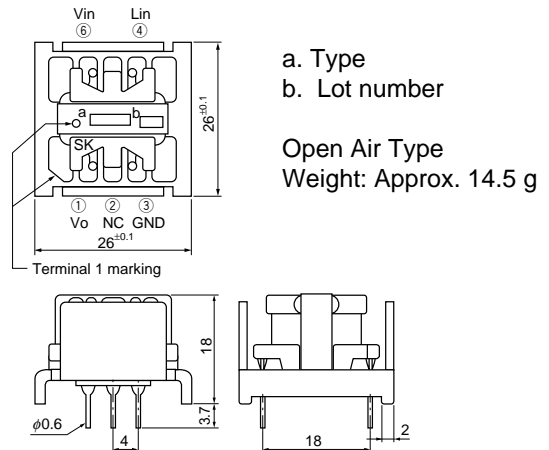

■ Standard External Circuit

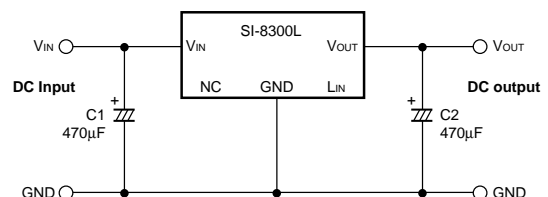
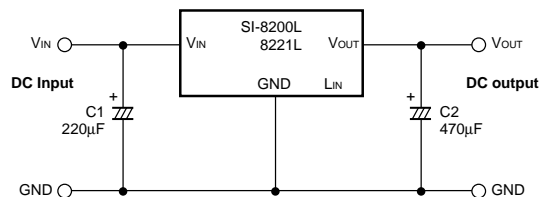

SI-8200L/8300L Series

Switching Type — Self Oscillation Type with Coil

■ Block Diagram

SI-8201L•8202L•8203L•8204L•8221L
SI-8301L•8303L

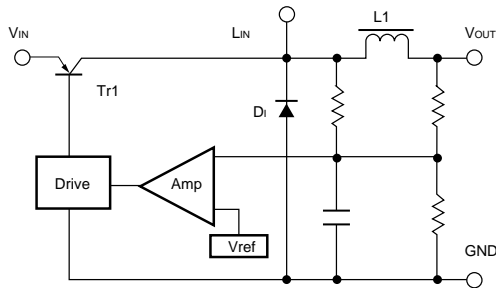

SI-8211L•8213L

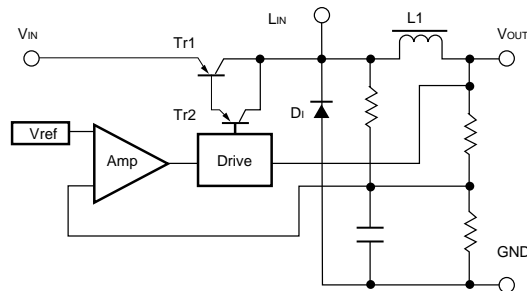

■ Ta-PD Characteristics

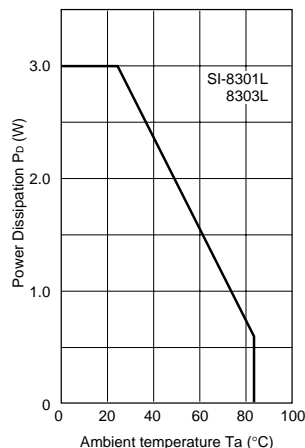
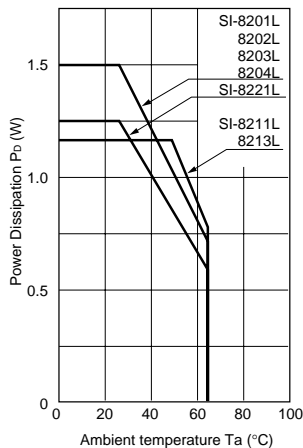

$$P_D = V_o \cdot I_o \left(\frac{100}{\eta\%} - 1 \right)$$

V_o : Output Voltage
 I_o : Output Current
 $\eta\%$: Efficiency

Note : The efficiency depends on the input voltage and the output current. Thus, obtain the value from the efficiency graph and substitute the percentage in the formula above.

■ Caution

1. A low-impedance capacitor suitable for switching applications must be used for the external capacitor and must be connected as close to the IC as possible in order to assure low ripple voltage and stable switching operation.
2. The SI-8200L and 8300L series do not have a built-in overcurrent protection circuit. Thus, avoid short-circuit conditions that may cause a flow of overcurrent.
3. The SI-8300L series may not start up if the input voltage rises too rapidly.
Do not use the SI-8300L series in applications where the input terminal, pin6, is opened and closed directly in a state where the input voltage is already applied.
4. Terminals LIN and NC in the connection diagram must be left unconnected to other circuits.
5. The IC's metallic heatsink is electrically floating. Do not connect it to GND or any other circuit.
6. Since the SI-8200L and 8300L series have an open-package construction, they can only be operated in specific environments. Verify the operating environment and use the IC within the conditions indicated in the reliability data.

SI-8200L/8300L Series Typical Operating Characteristics (Ta=25°C)

■ SI-8201L

Rise Characteristics

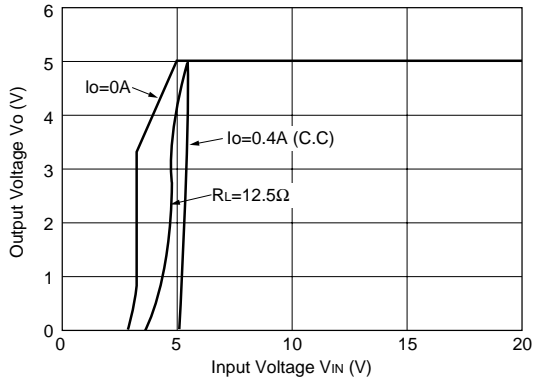

Efficiency Characteristics

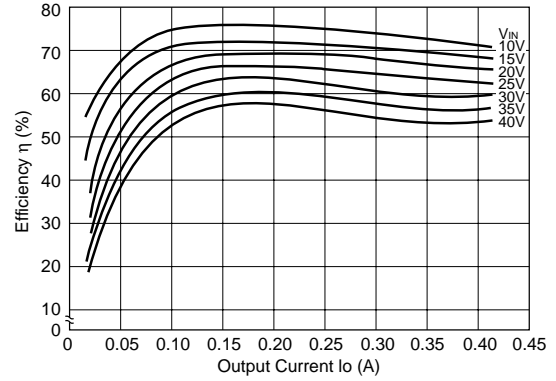

■ SI-8203L

Rise Characteristics

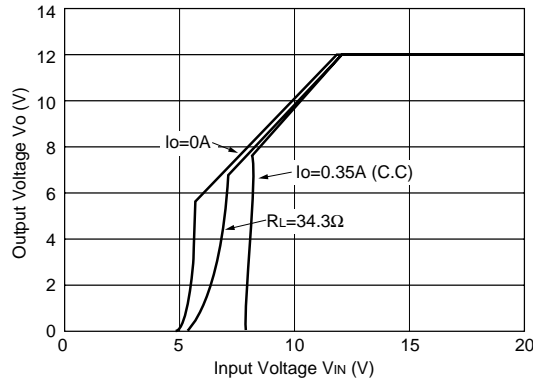

Efficiency Characteristics

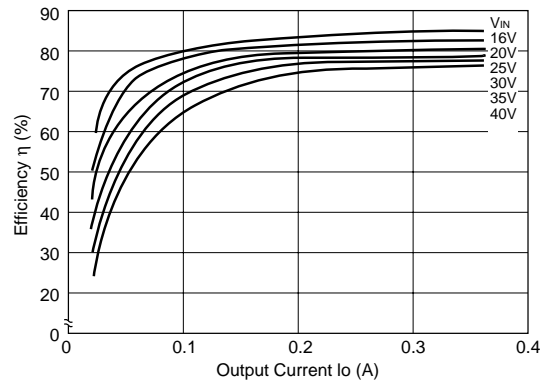

■ SI-8221L

Rise Characteristics

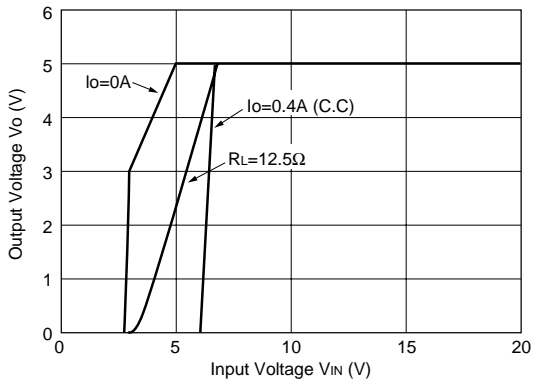

Efficiency Characteristics

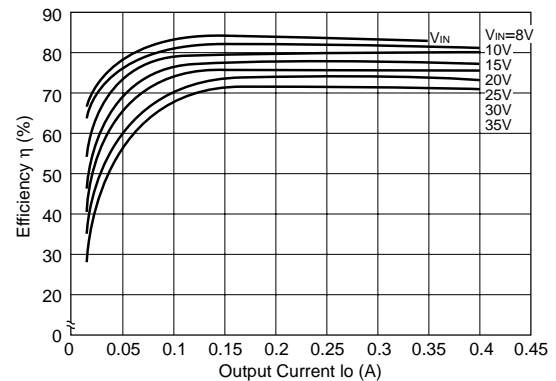

SI-8200L/8300L Series

SI-8200L/8300L Series Typical Operating Characteristics (Ta=25°C)

■ SI-8211L

Rise Characteristics

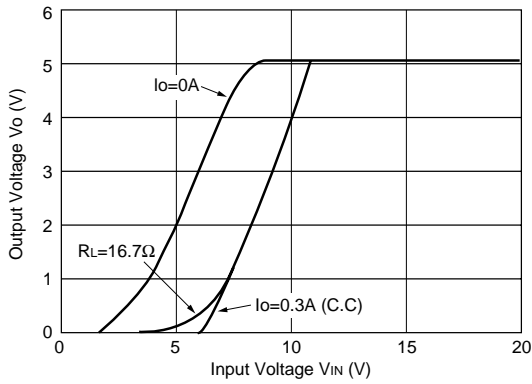

Efficiency Characteristics

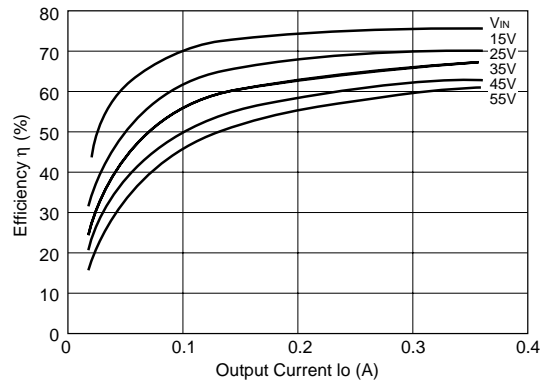

■ SI-8213L

Rise Characteristics

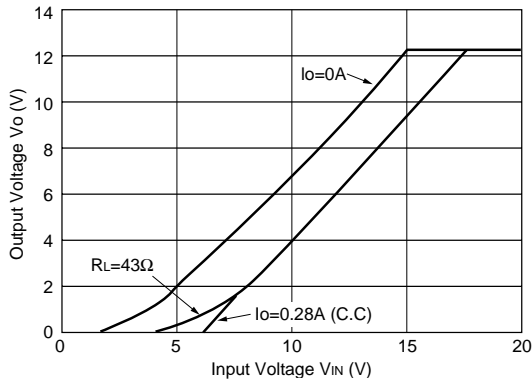

Efficiency Characteristics

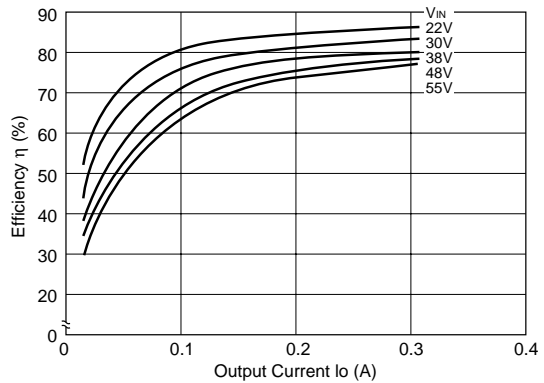

■ SI-8301L

Rise Characteristics

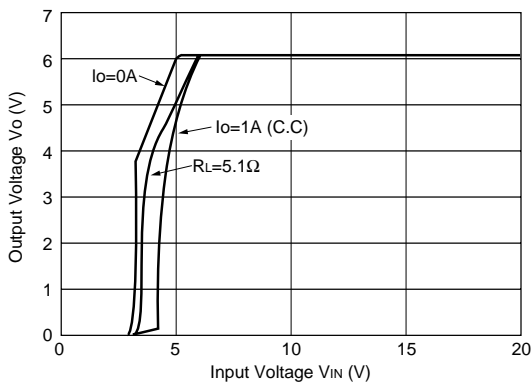

Efficiency Characteristics

