

# LM431

## Adjustable Precision Zener Shunt Regulator

### General Description

The LM431 is a 3-terminal adjustable shunt regulator with guaranteed temperature stability over the entire temperature range of operation. It is now available in a chip sized package (4-Bump micro SMD) using National's micro SMD package technology. The output voltage may be set at any level greater than 2.5V ( $V_{REF}$ ) up to 36V merely by selecting two external resistors that act as a voltage divided network. Due to the sharp turn-on characteristics this device is an excellent replacement for many zener diode applications.

### Features

- Average temperature coefficient 50 ppm/°C
- Temperature compensated for operation over the full temperature range
- Programmable output voltage
- Fast turn-on response
- Low output noise
- LM431 in micro SMD package
- See AN-1112 for micro SMD considerations

### Connection Diagrams

TO-92: Plastic Package

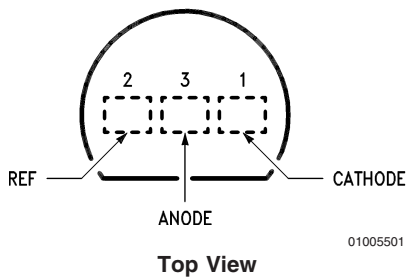

SOT-23: 3-Lead Small Outline

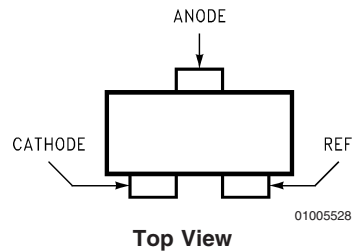

SO-8: 8-Pin Surface Mount

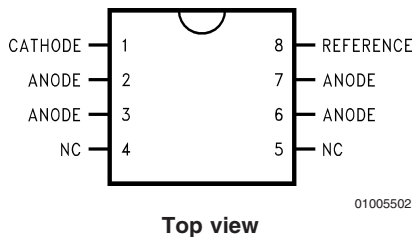

4-Bump micro SMD

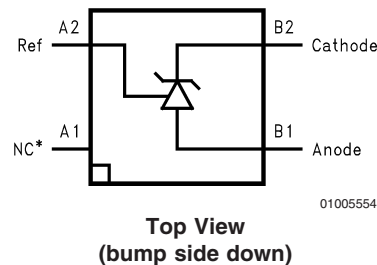

Note: \*NC = Not internally connected. Must be electrically isolated from the rest of the circuit for the microSMD package.

## Ordering Information

Package	Typical Accuracy Order Number/Package Marking			Temperature Range	Transport Media	NSC Drawing
	0.5%	1%	2%			
TO-92	LM431CCZ/ LM431CCZ	LM431BCZ/ LM431BCZ	LM431ACZ/ LM431ACZ	0°C to +70°C	Rails	Z03A
	LM431CIZ/ LM431CIZ	LM431BIZ/ LM431BIZ	LM431AIZ/ LM431AIZ	-40°C to +85°C		
SO-8	LM431CCM/ 431CCM	LM431BCM/ 431BCM	LM431ACM/ LM431ACM	0°C to +70°C	Rails	M08A
	LM431CCMX/ 431CCM	LM431BCM/ 431BCM	LM431ACMX/ LM431ACM		Tape & Reel	
	LM431CIM/ 431CIM	LM431BIM/ 431BIM	LM431AIM/ LM431AIM	-40°C to +85°C	Rails	
	LM431CIMX/ 431CIM	LM431BIMX/ 431BIM	LM431AIMX/ LM431AIM		Tape & Reel	
SOT-23	LM431CCM3/ N1B	LM431BCM3/ N1D	LM431ACM3/ N1F	0°C to +70°C	Rails	MF03A
	LM431CCM3X/ N1B	LM431BCM3X/ N1D	LM431ACM3X/ N1F		Tape & Reel	
	LM431CIM3 N1A	LM431BIM3 N1C	LM431AIM3 N1E	-40°C to +85°C	Rails	
	LM431CIM3X N1A	LM431BIM3X N1C	LM431AIM3X N1E		Tape & Reel	
micro SMD	-	-	LM431AIBP LM431AIBPX (Note 1)	-40°C to +85°C	250 Units Tape and Reel 3k Units Tape and Reel	BPA04AFB

**Note 1:** The micro SMD package marking is a 1 digit manufacturing Date Code only

### micro SMD Top View Marking Example

X = Date Code

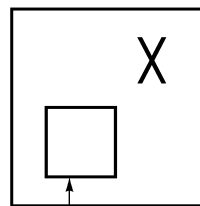

Pin A1 Identifier

01005556

# Symbol and Functional Diagrams

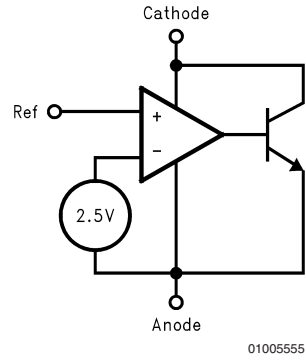
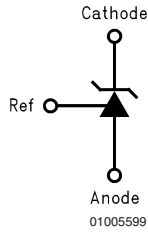

## DC Test Circuits

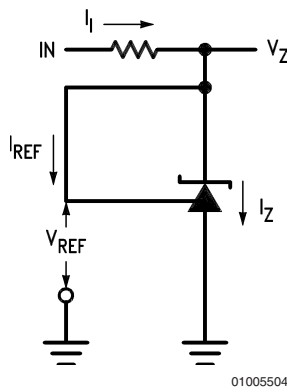
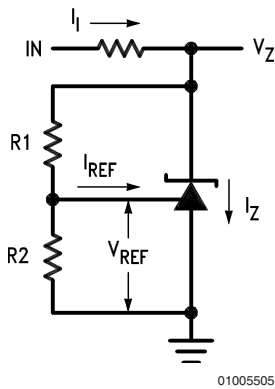
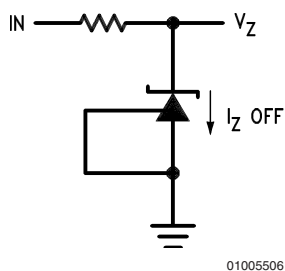

FIGURE 1. Test Circuit for  $V_Z = V_{REF}$



Note:  $V_Z = V_{REF} (1 + R1/R2) + I_{REF} \cdot R1$

FIGURE 2. Test Circuit for  $V_Z > V_{REF}$



Test Circuit for Off-State Current

**Absolute Maximum Ratings** (Note 2)

If Military/Aerospace specified devices are required, please contact the National Semiconductor Sales Office/Distributors for availability and specifications.

Storage Temperature Range	-65°C to +150°C
Operating Temperature Range	
Industrial (LM431xl)	-40°C to +85°C
Commercial (LM431xC)	0°C to +70°C
Soldering Information	
Infrared or Convection (20 sec.)	235°C
Wave Soldering (10 sec.)	260°C (lead temp.)
Cathode Voltage	37V
Continuous Cathode Current	-10 mA to +150 mA

Reference Voltage	-0.5V
Reference Input Current	10 mA
Internal Power Dissipation (Notes 3, 4)	
TO-92 Package	0.78W
SO-8 Package	0.81W
SOT-23 Package	0.28W
micro SMD Package	0.30W

**Operating Conditions**

	Min	Max
Cathode Voltage	$V_{REF}$	37V
Cathode Current	1.0 mA	100 mA

## LM431

### Electrical Characteristics

$T_A = 25^\circ\text{C}$  unless otherwise specified

Symbol	Parameter	Conditions	Min	Typ	Max	Units
$V_{REF}$	Reference Voltage	$V_Z = V_{REF}$ , $I_I = 10\text{ mA}$ LM431A (Figure 1)	2.440	2.495	2.550	V
		$V_Z = V_{REF}$ , $I_I = 10\text{ mA}$ LM431B (Figure 1)	2.470	2.495	2.520	V
		$V_Z = V_{REF}$ , $I_I = 10\text{ mA}$ LM431C (Figure 1)	2.485	2.500	2.510	V
$V_{DEV}$	Deviation of Reference Input Voltage Over Temperature (Note 5)	$V_Z = V_{REF}$ , $I_I = 10\text{ mA}$ , $T_A = \text{Full Range}$ (Figure 1)		8.0	17	mV
$\frac{\Delta V_{REF}}{\Delta V_Z}$	Ratio of the Change in Reference Voltage to the Change in Cathode Voltage	$I_Z = 10\text{ mA}$ (Figure 2)	$V_Z$ from $V_{REF}$ to 10V	-1.4	-2.7	mV/V
			$V_Z$ from 10V to 36V	-1.0	-2.0	
$I_{REF}$	Reference Input Current	$R_1 = 10\text{ k}\Omega$ , $R_2 = \infty$ , $I_I = 10\text{ mA}$ (Figure 2)		2.0	4.0	$\mu\text{A}$
$\infty I_{REF}$	Deviation of Reference Input Current over Temperature	$R_1 = 10\text{ k}\Omega$ , $R_2 = \infty$ , $I_I = 10\text{ mA}$ , $T_A = \text{Full Range}$ (Figure 2)		0.4	1.2	$\mu\text{A}$
$I_{Z(MIN)}$	Minimum Cathode Current for Regulation	$V_Z = V_{REF}$ (Figure 1)		0.4	1.0	mA
$I_{Z(OFF)}$	Off-State Current	$V_Z = 36\text{V}$ , $V_{REF} = 0\text{V}$ (Figure *NO TARGET FOR fi*)		0.3	1.0	$\mu\text{A}$
$r_Z$	Dynamic Output Impedance (Note 6)	$V_Z = V_{REF}$ , LM431A, Frequency = 0 Hz (Figure 1)			0.75	$\Omega$
		$V_Z = V_{REF}$ , LM431B, LM431C Frequency = 0 Hz (Figure 1)			0.50	$\Omega$

**Note 2:** Absolute Maximum Ratings indicate limits beyond which damage to the device may occur. Electrical specifications do not apply when operating the device beyond its rated operating conditions.

**Note 3:**  $T_{J\text{ Max}} = 150^\circ\text{C}$ .

**Note 4:** Ratings apply to ambient temperature at 25°C. Above this temperature, derate the TO-92 at 6.2 mW/°C, the SO-8 at 6.5 mW/°C, the SOT-23 at 2.2 mW/°C and the micro SMD at 3mW/°C.

**Note 5:** Deviation of reference input voltage,  $V_{DEV}$ , is defined as the maximum variation of the reference input voltage over the full temperature range.

## LM431

### Electrical Characteristics (Continued)



01005507

The average temperature coefficient of the reference input voltage,  $\alpha V_{REF}$ , is defined as:

$$\alpha V_{REF} \frac{\text{ppm}}{^{\circ}\text{C}} = \frac{\pm \left[ \frac{V_{\text{Max}} - V_{\text{Min}}}{V_{REF}(\text{at } 25^{\circ}\text{C})} \right] 10^6}{T_2 - T_1} = \frac{\pm \left[ \frac{V_{\text{DEV}}}{V_{REF}(\text{at } 25^{\circ}\text{C})} \right] 10^6}{T_2 - T_1}$$

Where:

$T_2 - T_1$  = full temperature change (0-70°C).

$\alpha V_{REF}$  can be positive or negative depending on whether the slope is positive or negative.

Example:  $V_{DEV} = 8.0 \text{ mV}$ ,  $V_{REF} = 2495 \text{ mV}$ ,  $T_2 - T_1 = 70^{\circ}\text{C}$ , slope is positive.

$$\alpha V_{REF} = \frac{\left[ \frac{8.0 \text{ mV}}{2495 \text{ mV}} \right] 10^6}{70^{\circ}\text{C}} = +46 \text{ ppm}/^{\circ}\text{C}$$

**Note 6:** The dynamic output impedance,  $r_z$ , is defined as:

$$r_z = \frac{\Delta V_z}{\Delta I_z}$$

When the device is programmed with two external resistors,  $R_1$  and  $R_2$ , (see Figure 2), the dynamic output impedance of the overall circuit,  $r_z$ , is defined as:

$$r_z = \frac{\Delta V_z}{\Delta I_z} \cong \left[ r_z \left( 1 + \frac{R_1}{R_2} \right) \right]$$

## Equivalent Circuit



01005503

## Typical Performance Characteristics

Input Current vs  $V_Z$



01005529

Thermal Information



01005530

Input Current vs  $V_Z$



01005531

Dynamic Impedance vs Frequency



01005509



Typical Applications (Continued)

Series Regulator

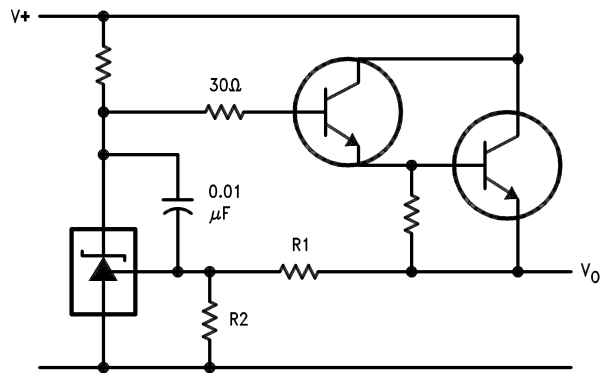

01005516

$$V_O \approx \left(1 + \frac{R_1}{R_2}\right) V_{REF}$$

Output Control of a Three Terminal Fixed Regulator

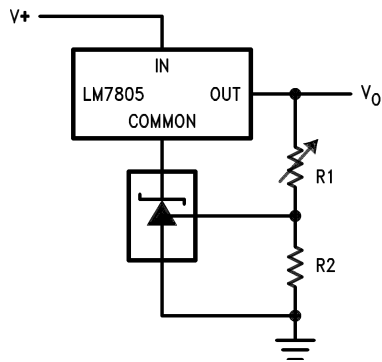

01005517

$$V_O = \left(1 + \frac{R_1}{R_2}\right) V_{REF}$$

$$V_{O\ MIN} = V_{REF} + 5V$$

Higher Current Shunt Regulator



01005518

$$V_O \approx \left(1 + \frac{R_1}{R_2}\right) V_{REF}$$

Crow Bar

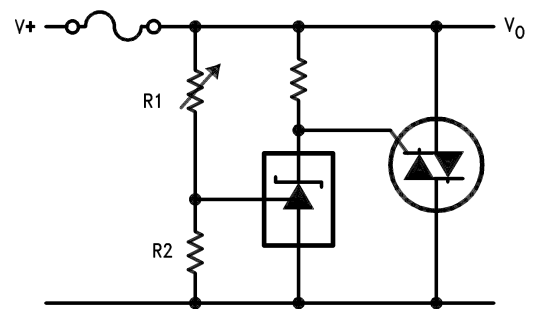

01005519

$$V_{LIMIT} \approx \left(1 + \frac{R_1}{R_2}\right) V_{REF}$$



## Typical Applications (Continued)

### Over Voltage/Under Voltage Protection Circuit



$$\text{LOW LIMIT} \approx V_{\text{REF}} \left( 1 + \frac{R1B}{R2B} \right) + V_{\text{BE}}$$

$$\text{HIGH LIMIT} \approx V_{\text{REF}} \left( 1 + \frac{R1A}{R2A} \right)$$

### Voltage Monitor

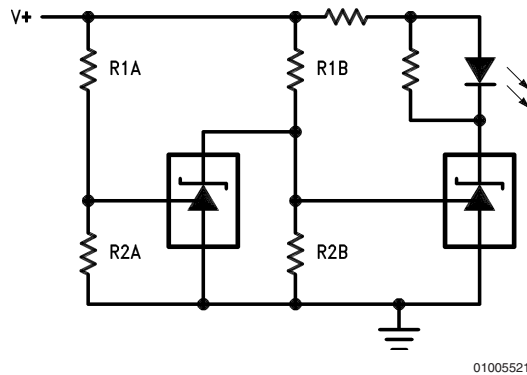

$$\text{LOW LIMIT} \approx V_{\text{REF}} \left( 1 + \frac{R1B}{R2B} \right)$$

$$\text{HIGH LIMIT} \approx V_{\text{REF}} \left( 1 + \frac{R1A}{R2A} \right)$$

## Typical Applications (Continued)

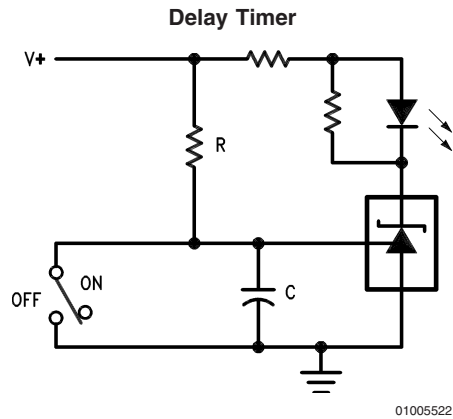

$$\text{DELAY} = R \cdot C \cdot \ln \frac{V+}{(V+) - V_{\text{REF}}}$$

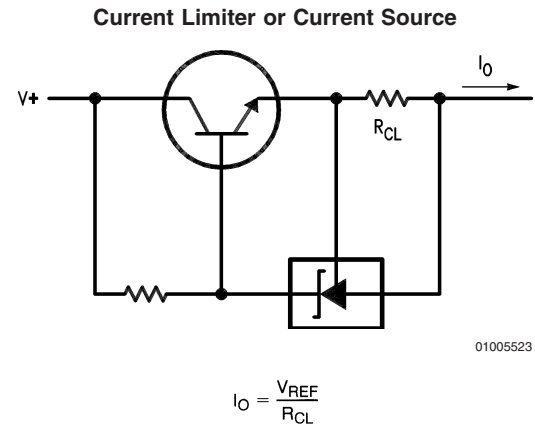

### Constant Current Sink

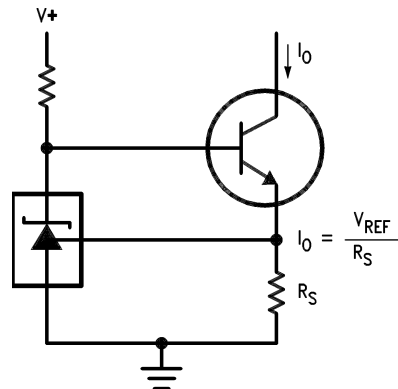

## Application Info

### 1.0 Mounting

To ensure that the geometry of the micro SMD package maintains good physical contact with the printed circuit board, pin A1 (NC) must be soldered to the pcb. Please see AN-1112 for more detailed information regarding board mounting techniques for the micro SMD package.

### 2.0 LM431 micro SMD Light Sensitivity

When the LM431 micro SMD package is exposed to bright sunlight, normal office fluorescent light, and other LED's and lasers, it operates within the guaranteed limits specified in the electrical characteristics table.

**Physical Dimensions** inches (millimeters) unless otherwise noted

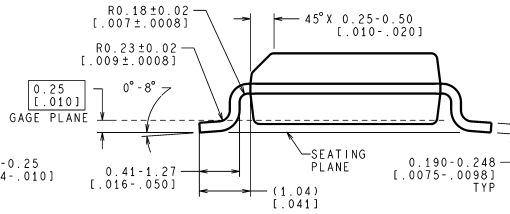
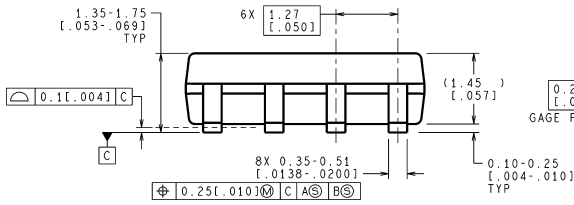
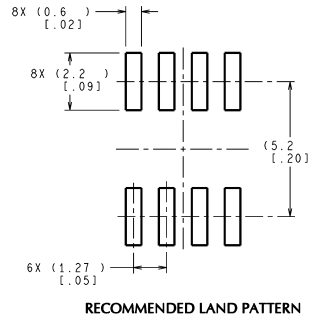
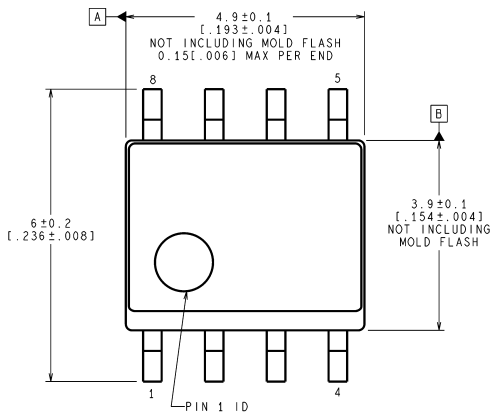

CONTROLLING DIMENSION IS MILLIMETER  
VALUES IN [ ] ARE INCHES  
DIMENSIONS IN ( ) FOR REFERENCE ONLY

M08A (Rev K)

**8-Pin SOIC  
NS Package Number M08A**

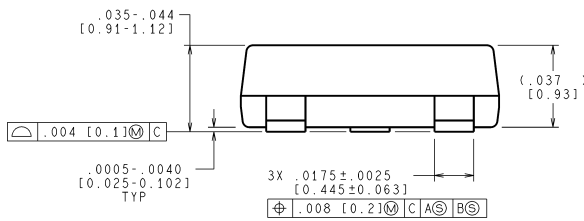
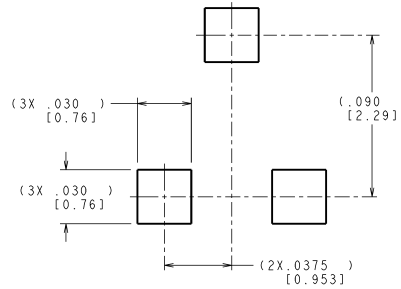

CONTROLLING DIMENSION IS INCH  
VALUES IN [ ] ARE MILLIMETERS

MF03A (Rev B)

**SOT-23 Molded Small Outline Transistor Package (M3)  
NS Package Number MF03A**

**Physical Dimensions** inches (millimeters) unless otherwise noted (Continued)



DIMENSIONS ARE IN MILLIMETERS

Z03A (Rev G)

**NS Package Number Z03A**

**Physical Dimensions** inches (millimeters) unless otherwise noted (Continued)

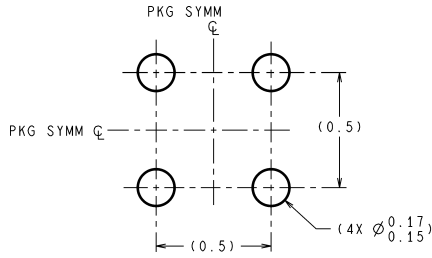

DIMENSIONS ARE IN MILLIMETERS  
DIMENSIONS IN ( ) FOR REFERENCE ONLY

**LAND PATTERN RECOMMENDATION**

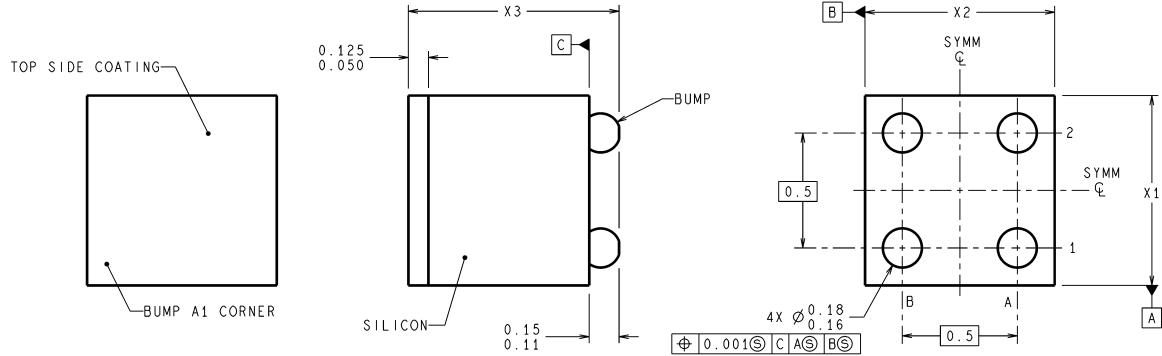

BPA04XXX (Rev E)

NOTES: UNLESS OTHERWISE SPECIFIED

1. EPOXY COATING
2. 63Sn/37Pb EUTECTIC BUMP
3. RECOMMEND NON-SOLDER MASK DEFINED LANDING PAD.
4. PIN A1 IS ESTABLISHED BY LOWER LEFT CORNER WITH RESPECT TO TEXT ORIENTATION. REMAINING PINS ARE NUMBERED.
5. XXX IN DRAWING NUMBER REPRESENTS PACKAGE SIZE VARIATION WHERE X1 IS PACKAGE WIDTH, X2 IS PACKAGE LENGTH AND X3 IS PACKAGE HEIGHT.
6. REFERENCE JEDEC REGISTRATION MO-211, VARIATION BA.

**4-Bump micro SMD**  
**X1 = 0.777 X2 = 0.904 X3 = 0.850**  
**NS Package Number BPA04AFB**

National does not assume any responsibility for use of any circuitry described, no circuit patent licenses are implied and National reserves the right at any time without notice to change said circuitry and specifications.

For the most current product information visit us at [www.national.com](http://www.national.com).

**LIFE SUPPORT POLICY**

NATIONAL'S PRODUCTS ARE NOT AUTHORIZED FOR USE AS CRITICAL COMPONENTS IN LIFE SUPPORT DEVICES OR SYSTEMS WITHOUT THE EXPRESS WRITTEN APPROVAL OF THE PRESIDENT AND GENERAL COUNSEL OF NATIONAL SEMICONDUCTOR CORPORATION. As used herein:

1. Life support devices or systems are devices or systems which, (a) are intended for surgical implant into the body, or (b) support or sustain life, and whose failure to perform when properly used in accordance with instructions for use provided in the labeling, can be reasonably expected to result in a significant injury to the user.
2. A critical component is any component of a life support device or system whose failure to perform can be reasonably expected to cause the failure of the life support device or system, or to affect its safety or effectiveness.

**BANNED SUBSTANCE COMPLIANCE**

National Semiconductor manufactures products and uses packing materials that meet the provisions of the Customer Products Stewardship Specification (CSP-9-111C2) and the Banned Substances and Materials of Interest Specification (CSP-9-111S2) and contain no "Banned Substances" as defined in CSP-9-111S2.

**National Semiconductor**  
**Americas Customer Support Center**  
 Email: [new.feedback@nsc.com](mailto:new.feedback@nsc.com)  
 Tel: 1-800-272-9959

**National Semiconductor**  
**Europe Customer Support Center**  
 Fax: +49 (0) 180-530 85 86  
 Email: [europa.support@nsc.com](mailto:europa.support@nsc.com)  
 Deutsch Tel: +49 (0) 69 9508 6208  
 English Tel: +44 (0) 870 24 0 2171  
 Français Tel: +33 (0) 1 41 91 8790

**National Semiconductor**  
**Asia Pacific Customer Support Center**  
 Email: [ap.support@nsc.com](mailto:ap.support@nsc.com)

**National Semiconductor**  
**Japan Customer Support Center**  
 Fax: 81-3-5639-7507  
 Email: [jpn.feedback@nsc.com](mailto:jpn.feedback@nsc.com)  
 Tel: 81-3-5639-7560

[www.national.com](http://www.national.com)