

PART NUMBER: MEH20

DESCRIPTION: incremental encoder

ELECTRICAL SPECIFICATIONS

output waveform	Square Wave
output signals	A, B, Z phase
current consumption	≤50 mA
frequency response	0~100 KHz
output phase difference	A, B phase difference 90° ± 45° (T/4±T/8) Z phase T±T/2 (see output waveform)
supply voltage	5 V dc ±10% (line driver output only), 5 V ~ 12 V dc ±10%, 24 V dc ± 10% (open collector output only)
output resolution (ppr)	40, 50, 60, 100, 200, 250, 256, 300, 360, 400, 500, 512, 600, 800, 1000, 1024, 1200, 1800, 2000, 2048, 2500, 3600
waveform rise/fall time	2μ or less (outout cable 1m or less)

MECHANICAL SPECIFICATIONS

max shaft load, radial:	19.6N (2kgf)	14.7N (1.5kgf) (600-3600 ppr)
axial:	9.8N (1kgf)	4.9N (0.5kgf) (600-3600 ppr)
starting torque	2 x 10 ⁻³ N·m (20 gf·cm)	
max rotational speed	6000 RPM	
shock resistance	500 m/s ² (50G), 3 times each on XYZ	
vibration proof	55 Hz, double amplitude 1.5mm, 2 hours each on XYZ	
weight	70g (with 1m cable)	
cable	4.2mm outside diameter, 5 core vinyl wire insulated shield cable (1m)	

ENVIRONMENTAL SPECIFICATIONS

operating temp	-10° to +70° C
storage temp	-20° to +80° C
humidity	RH 35%~90% non collecting

ORDERING INSTRUCTIONS
MEH20 - XXXXP-XX-XX

	Resolution (PPR):		Output Circuit:		Input Voltage:		Bore/Hub:
40 = 40 PPR	400 = 400 PPR	2000 = 2000 PPR	"no entry" = Voltage output		1 = 5V dc ± 10%		"no entry" = Through/No Hub
50 = 50 PPR	500 = 500 PPR	2048 = 2048 PPR	C = Open collector output		(line driver output only)		F1 = Through/Hub/Set Screw
60 = 60 PPR	512 = 512 PPR	2500 = 2500 PPR	E = Line driver output		3 = 5 ~ 12V dc ± 10%		
100 = 100 PPR	600 = 600 PPR	3600 = 3600 PPR			4 = 24V dc ± 10%		
200 = 200 PPR	800 = 800 PPR				(open collector output only)		
250 = 250 PPR	1000 = 1000 PPR						
256 = 256 PPR	1024 = 1024 PPR						
300 = 300 PPR	1200 = 1200 PPR						
360 = 360 PPR	1800 = 1800 PPR						

*F1 Bore/Hub is available only in resolutions below and not including 400PPR, see attached mechanical drawing

PART NUMBER: MEH20

DESCRIPTION: incremental encoder

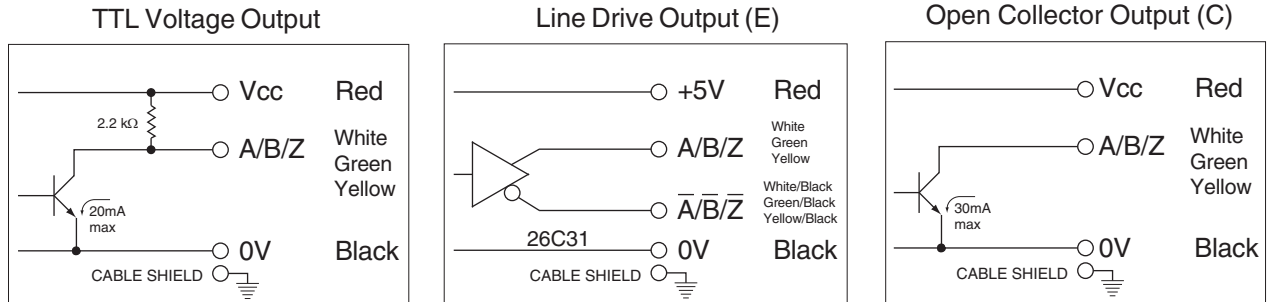
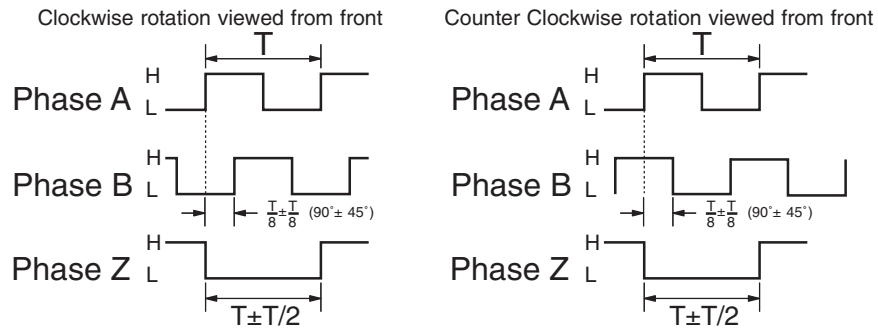
CIRCUIT CONNECTIONS

OUTPUT WAVEFORM

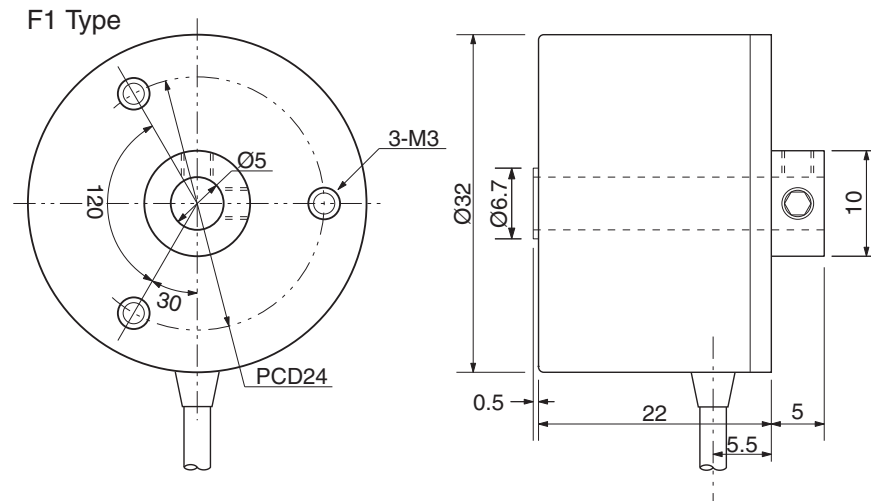
The position of Z phase against A, B phase is not specified

F1 MECHANICAL DRAWING

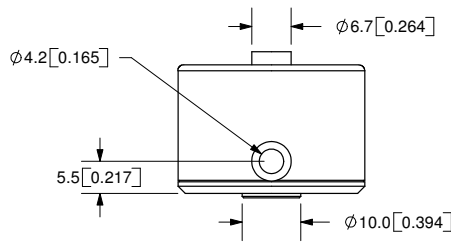
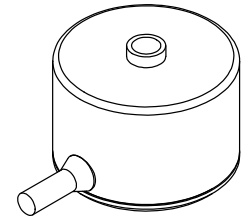
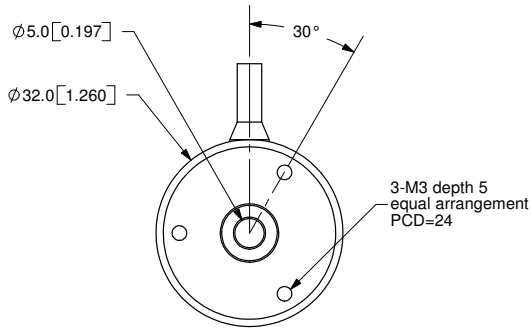
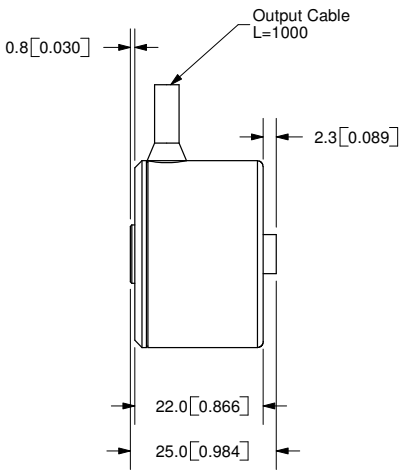
REV.	DESCRIPTION	DATE
A	NEW DRAWING	7/27/2007



TOLERANCE:
±0.3mm UNLESS OTHERWISE
SPECIFIED



20050 SW 112th Ave.
Tualatin, OR 97062
Phone: 503-612-2300
800-275-4899
Fax: 503-612-2383
Website: www.cui.com

TITLE: Incremental Encoder		REV: A
PART NO: MEH20		UNITS: MM [INCHES]
DRAWN BY: JMS	APPROVED BY:	SCALE: 1:1

PC FILE NAME: MEH20
COPYRIGHT 2007 BY CUI INC.

Cable Color	Red	White	Green	Yellow	Black	-	-	-
Output Type	Power	A-Phase	B-Phase	Z-Phase	0V	-	-	-