

**PART NUMBER:** MEH30

**DESCRIPTION:** incremental encoder

**ELECTRICAL SPECIFICATIONS**

output waveform	Square Wave
output signals	A, B, Z phase
current consumption	≤50 mA
frequency response	0~100 KHz
output phase difference	A, B phase difference 90° ± 45° (T/4±T/8) Z phase T±T/2 (see output waveform)
supply voltage	5 V dc (Line driver output only), 5 V ~ 12 V dc ± 10%, 24 V dc ± 10% (open collector output only)
output resolution (ppr)	40, 50, 60, 100, 200, 250, 300, 360, 400, 450, 500, 512, 600, 720, 800, 900, 1000, 1024, 1200, 1500, 1800, 2000, 2048, 2500, 3600, 4500, 9000
waveform rise/fall time	2μ or less (output cable 1m or less)

**MECHANICAL SPECIFICATIONS**

max shaft load, radial:	19.6N (2kgf)	14.7N (1.5kgf) (800-9000 ppr)
axial:	9.8N (1kgf)	4.9N (0.5kgf) (800-9000 ppr)
starting torque	2 x 10 <sup>-3</sup> N·m (20 gf·cm)	
max rotational speed	6000 RPM	
shock resistance	500 m/s <sup>2</sup> (50G), 3 times each on XYZ	
vibration proof	55 Hz, double amplitude 1.5mm, 2 hours each on XYZ	
weight	70g (with 1m cable)	
cable	4.2mm outside diameter, 5 core vinyl wire insulated shield cable (1m)	

**ENVIRONMENTAL SPECIFICATIONS**

operating temp	-10° to +70° C
storage temp	-20° to +80° C
humidity	RH 35%~90% non collecting

**ORDERING INSTRUCTIONS**
**MEH30 - XXXXP-XX-XX-XX**

Resolution (PPR):			Output Circuit:	Input Voltage:	Bore Size:	Bore/Hub:
40 = 40 PPR*	450 = 450 PPR*	1200 = 1200 PPR	"no entry" = Voltage output	1 = 5V dc ± 10%	8 = 8mm	"no entry" = Through/No Hub
50 = 50 PPR*	500 = 500 PPR*	1500 = 1500 PPR	C = Open collector output	(line driver output only)	10 = 10mm	F1 = Through/Hub/Set Screw
60 = 60 PPR*	512 = 512 PPR*	1800 = 1800 PPR	E = Line driver output	3 = 5 ~ 12V dc ± 10%		
100 = 100 PPR*	600 = 600 PPR	2000 = 2000 PPR		4 = 24V dc ± 10%		
200 = 200 PPR*	720 = 720 PPR	2048 = 2048 PPR		(open collector output only)		
250 = 250 PPR*	800 = 800 PPR	2500 = 2500 PPR				
300 = 300 PPR*	900 = 900 PPR	3600 = 3600 PPR				
360 = 360 PPR*	1000 = 1000 PPR	4500 = 4500 PPR				
400 = 400 PPR*	1024 = 1024 PPR	9000 = 9000 PPR				

\*signifies only resolutions available with F1 Bore/Hub

**PART NUMBER:** MEH30

**DESCRIPTION:** incremental encoder

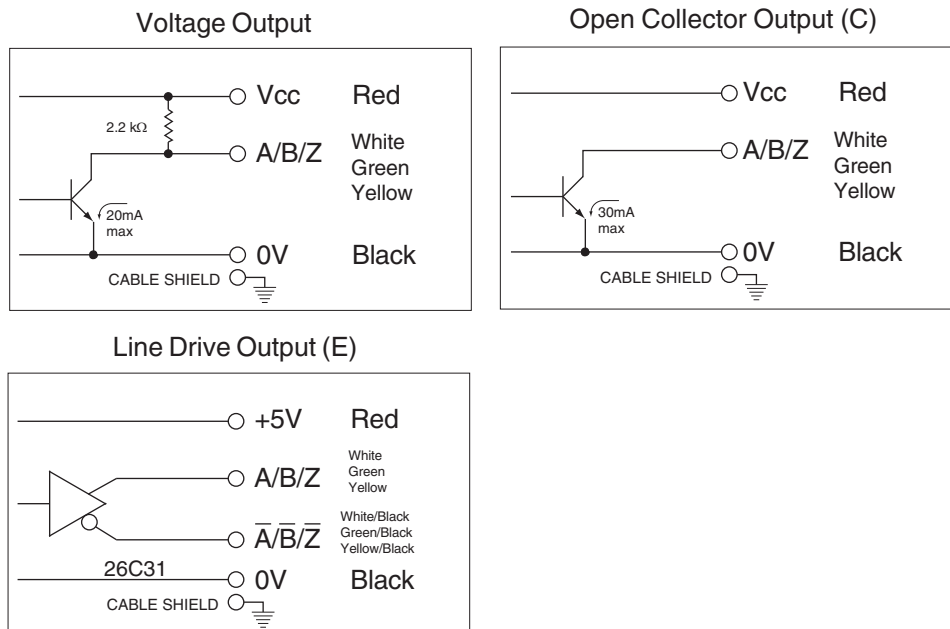
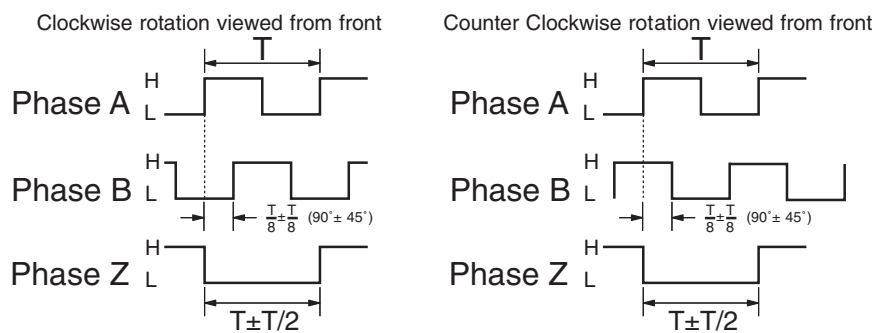
**CIRCUIT CONNECTIONS**

**OUTPUT WAVEFORM**

The position of Z phase against A, B phase is not specified

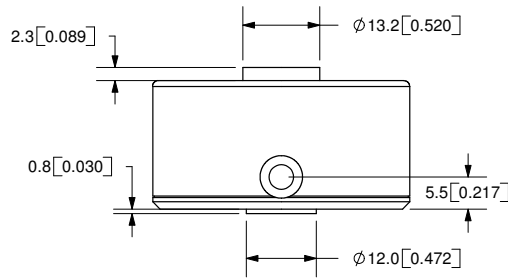
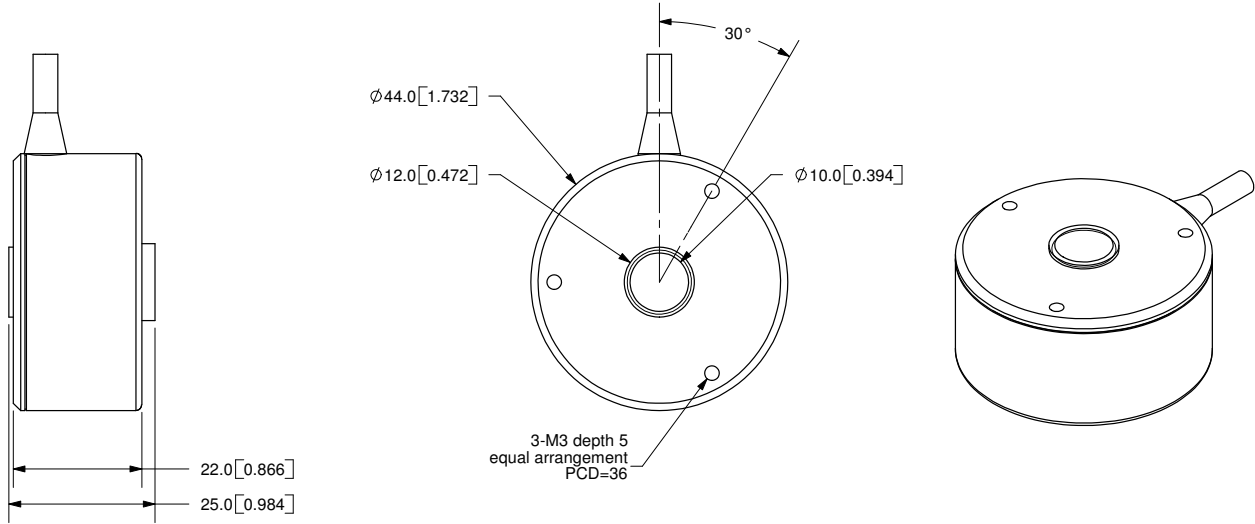
REV.	DESCRIPTION	DATE
A	NEW DRAWING	7/30/2007



TOLERANCE:  
±0.3mm UNLESS OTHERWISE  
SPECIFIED



20050 SW 112th Ave.  
Tualatin, OR 97062  
Phone: 503-612-2300  
800-275-4899  
Fax: 503-612-2383  
Website: www.cui.com

TITLE: Incremental Encoder		REV: A
PART NO. MEH30		UNITS: MM [INCHES]
DRAWN BY: JMS	APPROVED BY:	SCALE: 1:1

PC FILE NAME:  
MEH30

COPYRIGHT 2007  
BY CUI INC.

Cable Color	Red	White	Green	Yellow	Black	-	-	-
Output Type	Power	A-Phase	B-Phase	Z-Phase	0V	-	-	-