

**PART NUMBER:** MES30

**DESCRIPTION:** incremental encoder

**ELECTRICAL SPECIFICATIONS**

output waveform	Square Wave
output signals	A, B, Z phase
current consumption	≤50 mA
frequency response	0~100 KHz
output phase difference	A, B phase difference 90° ± 45° (T/4±T/8) Z phase T±T/2 (see output waveform)
supply voltage	5 V dc ± 10% (line driver output only), 5 ~ 12 V dc ± 10%, 24 V dc ± 10% (open collector output only)
output resolution (ppr)	40, 50, 60, 100, 200, 250, 300, 360, 400, 450, 500, 512, 600, 720, 800, 900, 1000, 1024, 1200, 1500, 1800, 2000, 2048, 2500, 3600, 4500, 9000
waveform rise/fall time	2μ or less (output cable 1m or less)

**MECHANICAL SPECIFICATIONS**

max shaft load, radial:	19.6N (2kgf)	14.7N (1.5kgf) (800-9000 ppr)
axial:	9.8N (1kgf)	4.9N (0.5kgf) (800-9000 ppr)
starting torque	2 x 10 <sup>-3</sup> N·m (20 gf·cm)	
max rotational speed	6000 RPM	
shock resistance	500 m/s <sup>2</sup> (50G), 3 times each on XYZ	
vibration proof	55 Hz, double amplitude 1.5mm, 2 hours each on XYZ	
weight	70g (with 1m cable)	
cable	4.2mm outside diameter, 5 core vinyl wire insulated shield cable (1m)	

**ENVIRONMENTAL SPECIFICATIONS**

operating temp	-10° to +70° C
storage temp	-20° to +80° C
humidity	RH 35%~90% non collecting

**ORDERING INSTRUCTIONS**

## MES30 - XXXXP-XX

	<b>Resolution (PPR):</b>	<b>Output Circuit:</b>	<b>Input Voltage:</b>
40 = 40 PPR	450 = 450 PPR	"no entry" = TTL voltage output	1 = 5V dc ± 10%
50 = 50 PPR	500 = 500 PPR	C = Open collector output	(line driver output only)
60 = 60 PPR	512 = 512 PPR	E = Line driver output	3 = 5 ~ 12V dc ± 10%
100 = 100 PPR	600 = 600 PPR		4 = 24V dc ± 10%
200 = 200 PPR	720 = 720 PPR		(open collector output only)
250 = 250 PPR	800 = 800 PPR		
300 = 300 PPR	900 = 900 PPR		
360 = 360 PPR	1000 = 1000 PPR		
400 = 400 PPR	1024 = 1024 PPR		
	1200 = 1200 PPR		
	1500 = 1500 PPR		
	1800 = 1800 PPR		
	2000 = 2000 PPR		
	2048 = 2048 PPR		
	2500 = 2500 PPR		
	3600 = 3600 PPR		
	4500 = 4500 PPR		
	9000 = 9000 PPR		

**PART NUMBER:** MES30

**DESCRIPTION:** incremental encoder

## CIRCUIT CONNECTIONS

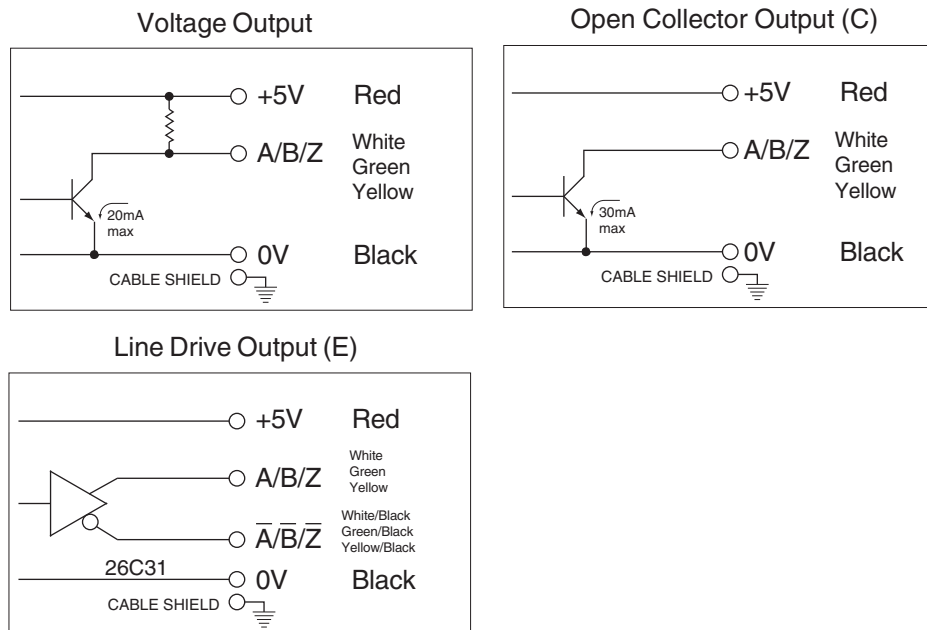

## OUTPUT WAVEFORM

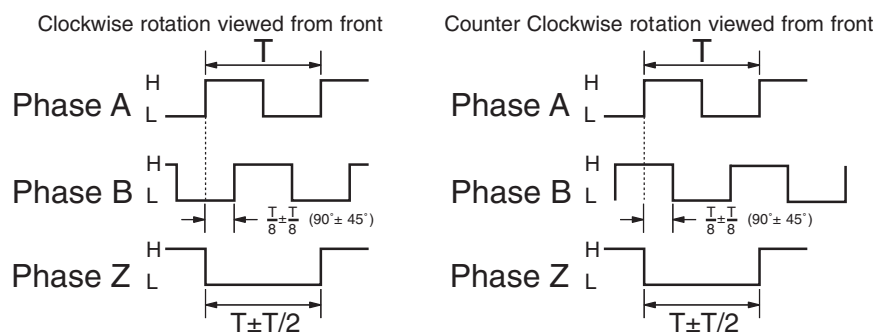

The position of Z phase against A, B phase is not specified

REV.	DESCRIPTION	DATE
A	NEW DRAWING	7/30/2007

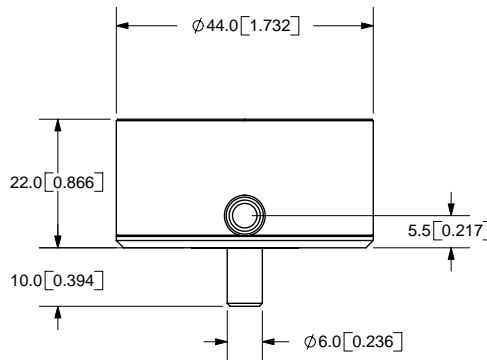
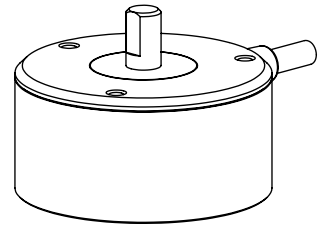
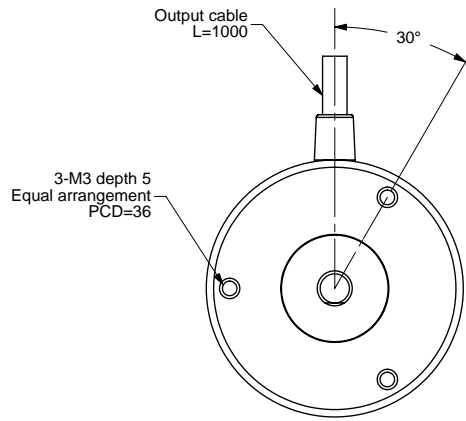
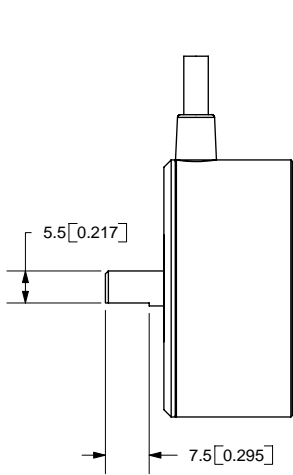

TOLERANCE:  
±0.3mm UNLESS OTHERWISE  
SPECIFIED



20050 SW 112th Ave.  
Tualatin, OR 97062  
Phone: 503-612-2300  
800-275-4899  
Fax: 503-612-2383  
Website: www.cui.com

TITLE: Incremental Encoder		REV: A
PART NO. MES30	UNITS: MM [INCHES]	
DRAWN BY: JMS	APPROVED BY:	SCALE: 1:1

PC FILE NAME:  
MES30

COPYRIGHT 2007  
BY CUI, INC.

Cable Color	Red	White	Green	Yellow	Black	-	-	-
Output Type	Power	A-Phase	B-Phase	Z-Phase	0V	-	-	-