

LM2830

High Frequency 1.0A Load - Step-Down DC-DC Regulator

General Description

The LM2830 regulator is a monolithic, high frequency, PWM step-down DC/DC converter in a 5 pin SOT23 and a 6 Pin LLP package. It provides all the active functions to provide local DC/DC conversion with fast transient response and accurate regulation in the smallest possible PCB area. With a minimum of external components, the LM2830 is easy to use. The ability to drive 1.0A loads with an internal 130 mΩ PMOS switch using state-of-the-art 0.5 μm BiCMOS technology results in the best power density available. The world-class control circuitry allows on-times as low as 30ns, thus supporting exceptionally high frequency conversion over the entire 3V to 5.5V input operating range down to the minimum output voltage of 0.6V. Switching frequency is internally set to 1.6 MHz, or 3.0 MHz, allowing the use of extremely small surface mount inductors and chip capacitors. Even though the operating frequency is high, efficiencies up to 93% are easy to achieve. External shutdown is included, featuring an ultra-low stand-by current of 30 nA. The LM2830 utilizes current-mode control and internal compensation to provide high-performance regulation over a wide range of operating conditions. Additional features include internal soft-start circuitry to reduce inrush current, pulse-by-pulse current limit, thermal shutdown, and output over-voltage protection.

Features

- Space Saving SOT23-5 Package
- Input voltage range of 3.0V to 5.5V
- Output voltage range of 0.6V to 4.5V
- 1.0A output current
- High Switching Frequencies
 - 1.6MHz (LM2830X)
 - 3.0MHz (LM2830Z)
- 130mΩ PMOS switch
- 0.6V, 2% Internal Voltage Reference
- Internal soft-start
- Current mode, PWM operation
- Thermal Shutdown
- Over voltage protection

Applications

- Local 5V to Vcore Step-Down Converters
- Core Power in HDDs
- Set-Top Boxes
- USB Powered Devices
- DSL Modems

Typical Application Circuit

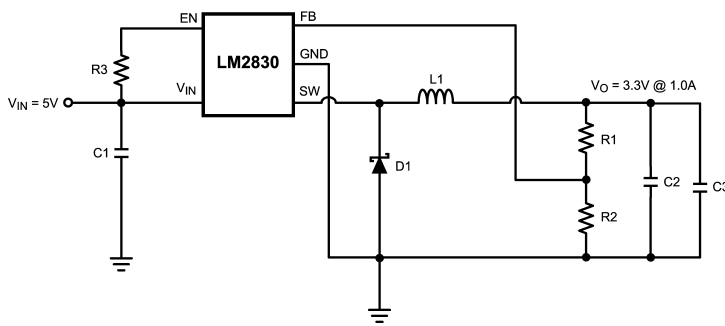

20197464

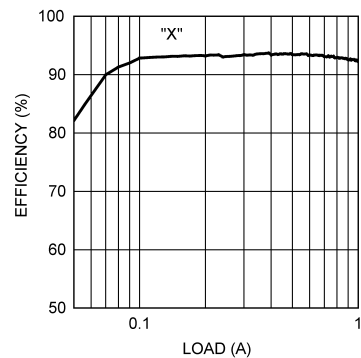

20197481

Connection Diagrams

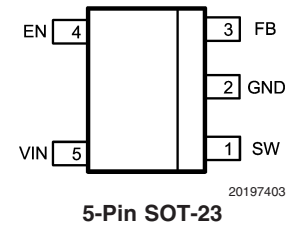
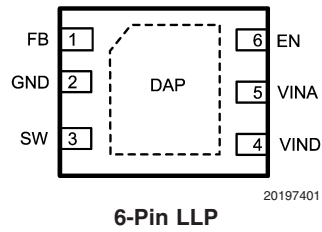

Ordering Information

Order Number	Frequency Option	Package Type	NSC Package Drawing	Top Mark	Supplied As
LM2830XMF	1.6MHz	SOT23-5	MF05A	SKTB	1000 units Tape and Reel
LM2830XMFX					3000 units Tape and Reel
LM2830ZMF	3MHz	SOT23-5	MF05A	SKXB	1000 units Tape and Reel
LM2830ZMFX					3000 units Tape and Reel
LM2830ZSD		LLP-6	SDE06A	L192B	1000 units Tape and Reel
LM2830ZSDX					4500 units Tape and Reel

NOPB versions available as well

Pin Descriptions 5-Pin SOT23

Pin	Name	Function
1	SW	Output switch. Connect to the inductor and catch diode.
2	GND	Signal and power ground pin. Place the bottom resistor of the feedback network as close as possible to this pin.
3	FB	Feedback pin. Connect to external resistor divider to set output voltage.
4	EN	Enable control input. Logic high enables operation. Do not allow this pin to float or be greater than $V_{IN} + 0.3V$.
5	VIN	Input supply voltage.

Pin Descriptions 6-Pin LLP

Pin	Name	Function
1	FB	Feedback pin. Connect to external resistor divider to set output voltage.
2	GND	Signal and power ground pin. Place the bottom resistor of the feedback network as close as possible to this pin.
3	SW	Output switch. Connect to the inductor and catch diode.
4	VIND	Power Input supply.
5	VINA	Control circuitry supply voltage. Connect VINA to VIND on PC board.
6	EN	Enable control input. Logic high enables operation. Do not allow this pin to float or be greater than $V_{INA} + 0.3V$.
DAP	Die Attach Pad	Connect to system ground for low thermal impedance, but it cannot be used as a primary GND connection.

Absolute Maximum Ratings (Note 1)

If Military/Aerospace specified devices are required, please contact the National Semiconductor Sales Office/Distributors for availability and specifications.

V _{IN}	-0.5V to 7V
FB Voltage	-0.5V to 3V
EN Voltage	-0.5V to 7V
SW Voltage	-0.5V to 7V
ESD Susceptibility	2kV
Junction Temperature (Note 2)	150°C

Storage Temperature	-65°C to +150°C
Soldering Information	
Infrared or Convection Reflow (15 sec)	220°C

Operating Ratings

V _{IN}	3V to 5.5V
Junction Temperature	-40°C to +125°C

Electrical Characteristics

V_{IN} = 5V unless otherwise indicated under the **Conditions** column. Limits in standard type are for T_J = 25°C only; limits in **boldface type** apply over the junction temperature (T_J) range of -40°C to +125°C. Minimum and Maximum limits are guaranteed through test, design, or statistical correlation. Typical values represent the most likely parametric norm at T_J = 25°C, and are provided for reference purposes only.

Symbol	Parameter	Conditions	Min	Typ	Max	Units
V _{FB}	Feedback Voltage	LLP-6 and SOT23-5 Package	0.588	0.600	0.612	V
$\Delta V_{FB}/V_{IN}$	Feedback Voltage Line Regulation	V _{IN} = 3V to 5V		0.02		%/V
I _B	Feedback Input Bias Current			0.1	100	nA
UVLO	Undervoltage Lockout	V _{IN} Rising		2.73	2.90	V
		V _{IN} Falling	1.85	2.3		
	UVLO Hysteresis			0.43		V
F _{SW}	Switching Frequency	LM2830-X	1.2	1.6	1.95	MHz
		LM2830-Z	2.25	3.0	3.75	
D _{MAX}	Maximum Duty Cycle	LM2830-X	86	94		%
		LM2830-Z	82	90		
D _{MIN}	Minimum Duty Cycle	LM2830-X		5		%
		LM2830-Z		7		
R _{DS(ON)}	Switch On Resistance	LLP-6 Package		150		mΩ
		SOT23-5 Package		130	195	
I _{CL}	Switch Current Limit	V _{IN} = 3.3V	1.2	1.75		A
V _{EN_TH}	Shutdown Threshold Voltage				0.4	V
	Enable Threshold Voltage		1.8			
I _{SW}	Switch Leakage			100		nA
I _{EN}	Enable Pin Current	Sink/Source		100		nA
I _Q	Quiescent Current (switching)	LM2830X V _{FB} = 0.55		3.3	5	mA
		LM2830Z V _{FB} = 0.55		4.3	6.5	mA
	Quiescent Current (shutdown)	All Options V _{EN} = 0V		30		nA

Electrical Characteristics

$V_{IN} = 5V$ unless otherwise indicated under the **Conditions** column. Limits in standard type are for $T_J = 25^\circ\text{C}$ only; limits in **boldface type** apply over the junction temperature (T_J) range of -40°C to $+125^\circ\text{C}$. Minimum and Maximum limits are guaranteed through test, design, or statistical correlation. Typical values represent the most likely parametric norm at $T_J = 25^\circ\text{C}$, and are provided for reference purposes only. (Continued)

Symbol	Parameter	Conditions	Min	Typ	Max	Units
θ_{JA}	Junction to Ambient 0 LFPM Air Flow (Note 3)	LLP-6 Package		80		$^\circ\text{C/W}$
		SOT23-5 Package		118		
θ_{JC}	Junction to Case (Note 3)	LLP-6 Package		18		$^\circ\text{C/W}$
		SOT23-5 Package		80		
T_{SD}	Thermal Shutdown Temperature			165		$^\circ\text{C}$

Note 1: Absolute maximum ratings indicate limits beyond which damage to the device may occur. Operating Range indicates conditions for which the device is intended to be functional, but does not guarantee specific performance limits. For guaranteed specifications and test conditions, see the Electrical Characteristics.

Note 2: Thermal shutdown will occur if the junction temperature exceeds the maximum junction temperature of the device.

Note 3: Applies for packages soldered directly onto a 3" x 3" PC board with 2oz. copper on 4 layers in still air.

Typical Performance Characteristics All curves taken at $V_{IN} = 5.0V$ with configuration in typical application circuit shown in Application Information section of this datasheet. $T_J = 25^\circ C$, unless otherwise specified.

η vs Load "X" $V_{in} = 5V, V_o = 1.8V \& 3.3V$

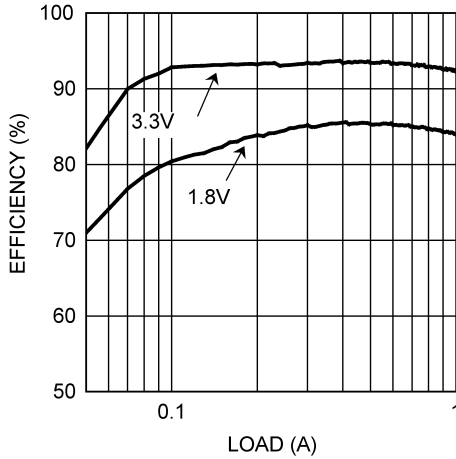

20197439

η vs Load "Z" $V_{in} = 5V, V_o = 3.3V \& 1.8V$

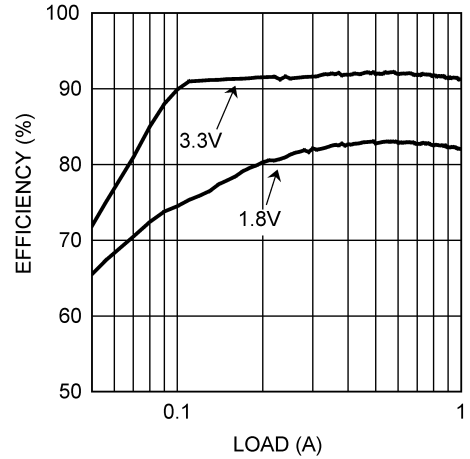

20197442

η vs Load "X and Z" $V_{in} = 3.3V, V_o = 1.8V$

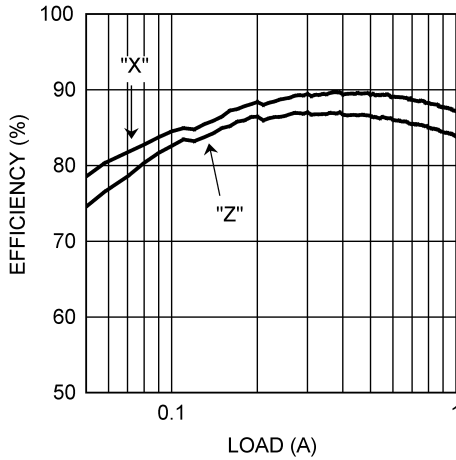

20197489

Load Regulation
 $V_{in} = 3.3V, V_o = 1.8V$ (All Options)

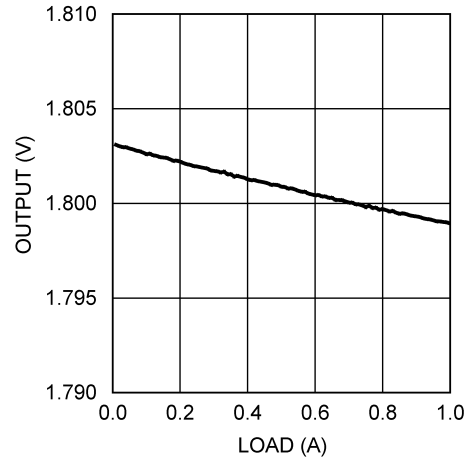

20197483

Load Regulation
 $V_{in} = 5V, V_o = 1.8V$ (All Options)

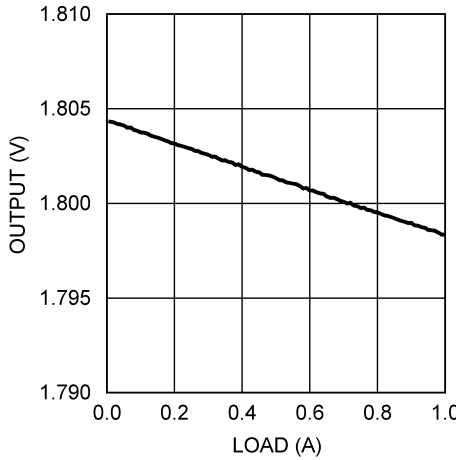

20197484

Load Regulation
 $V_{in} = 5V, V_o = 3.3V$ (All Options)

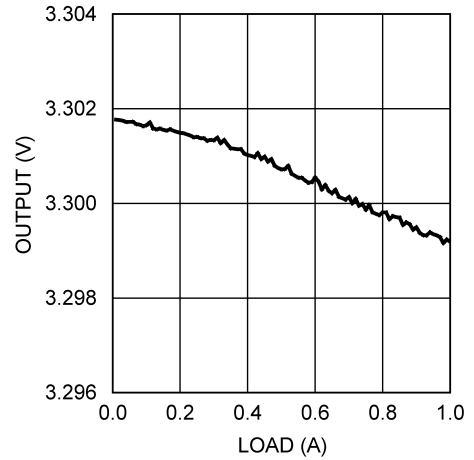

20197485

Typical Performance Characteristics All curves taken at $V_{IN} = 5.0V$ with configuration in typical application circuit shown in Application Information section of this datasheet. $T_J = 25^\circ C$, unless otherwise specified. (Continued)

Oscillator Frequency vs Temperature - "X"

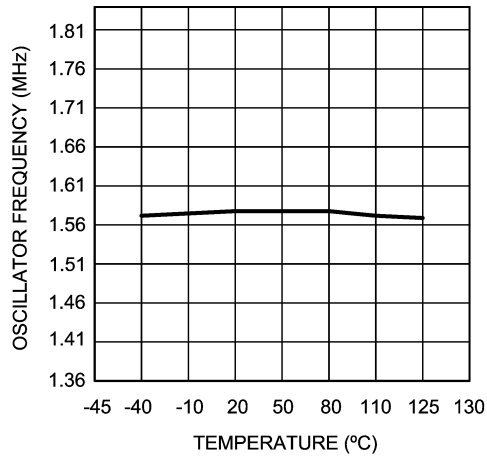

20197424

Oscillator Frequency vs Temperature - "Z"

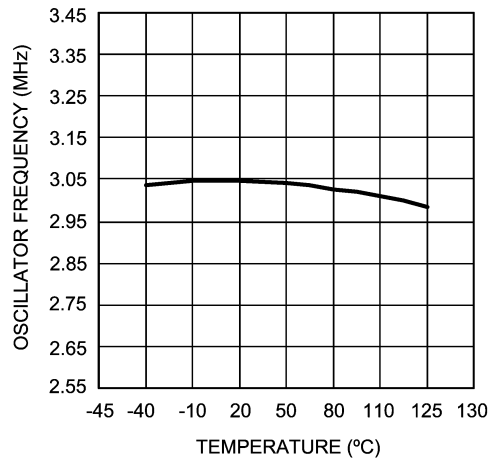

20197436

**Current Limit vs Temperature
 $V_{in} = 3.3V$**

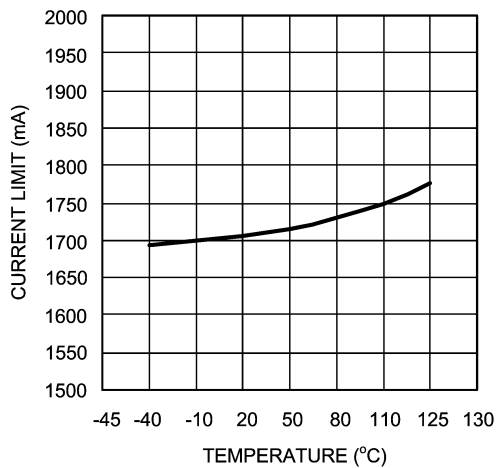

20197486

RDSON vs Temperature (LLP-6 Package)

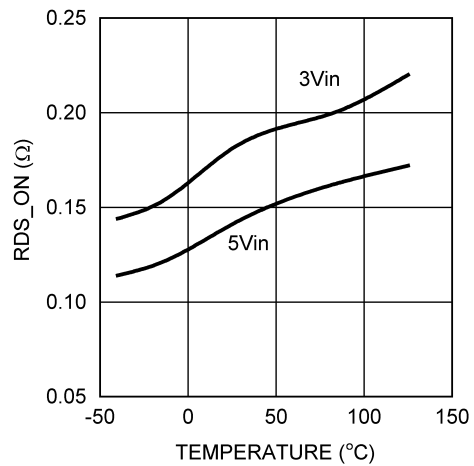

20197487

RDSON vs Temperature (SOT23-5 Package)

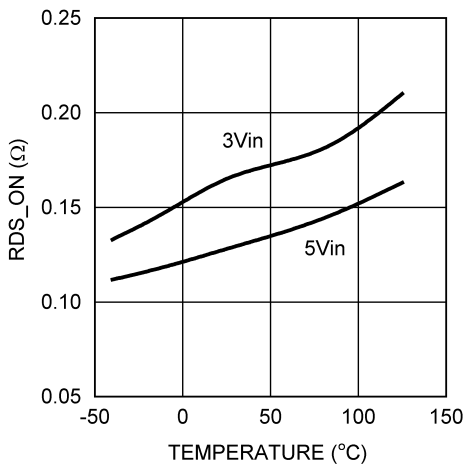

20197488

LM2830X I_Q (Quiescent Current)

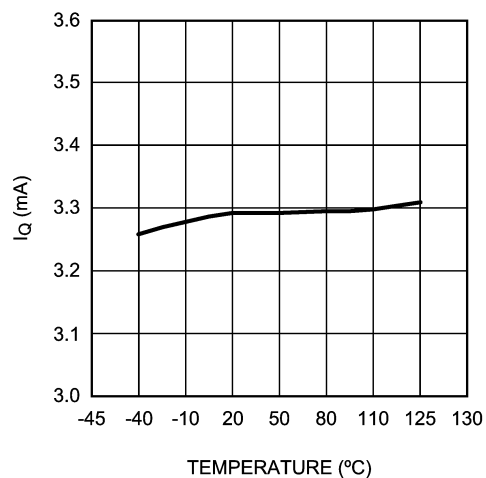

20197428

Typical Performance Characteristics All curves taken at $V_{IN} = 5.0V$ with configuration in typical application circuit shown in Application Information section of this datasheet. $T_J = 25^\circ C$, unless otherwise specified. (Continued)

LM2830Z I_Q (Quiescent Current)

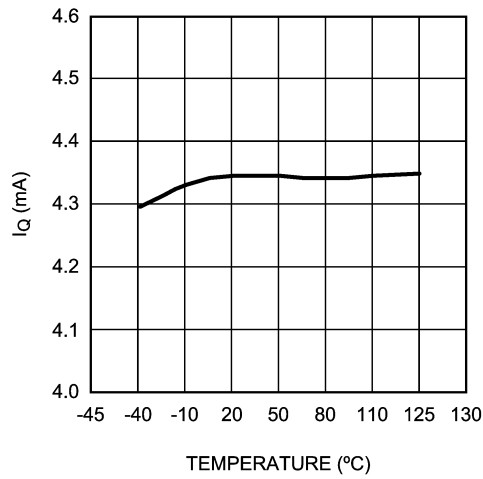

20197437

Line Regulation
 $V_o = 1.8V, I_o = 500mA$

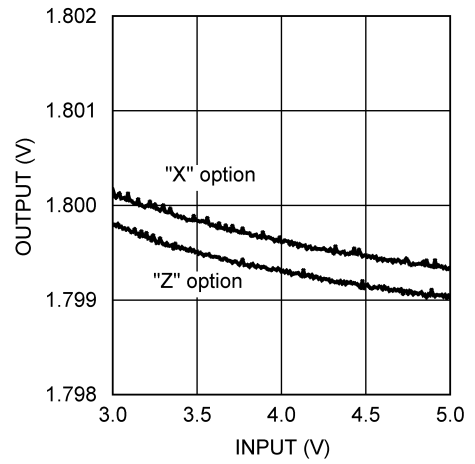

20197453

V_{FB} vs Temperature

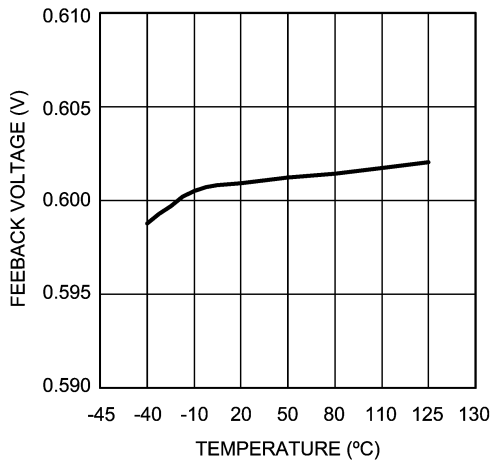

20197427

Gain vs Frequency
($V_{in} = 5V, V_o = 1.2V @ 1A$)

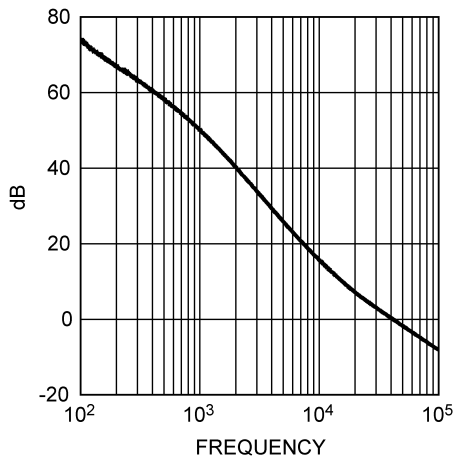

20197456

Phase Plot vs Frequency
($V_{in} = 5V, V_o = 1.2V @ 1A$)

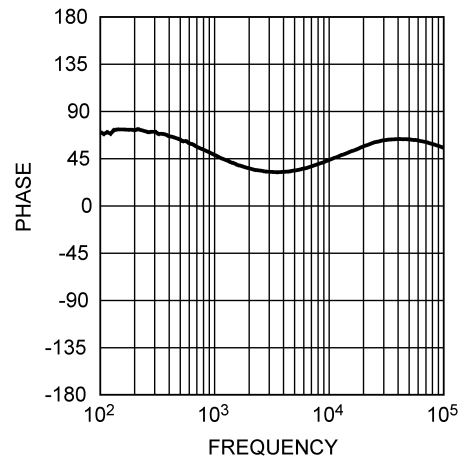

20197457

Simplified Block Diagram

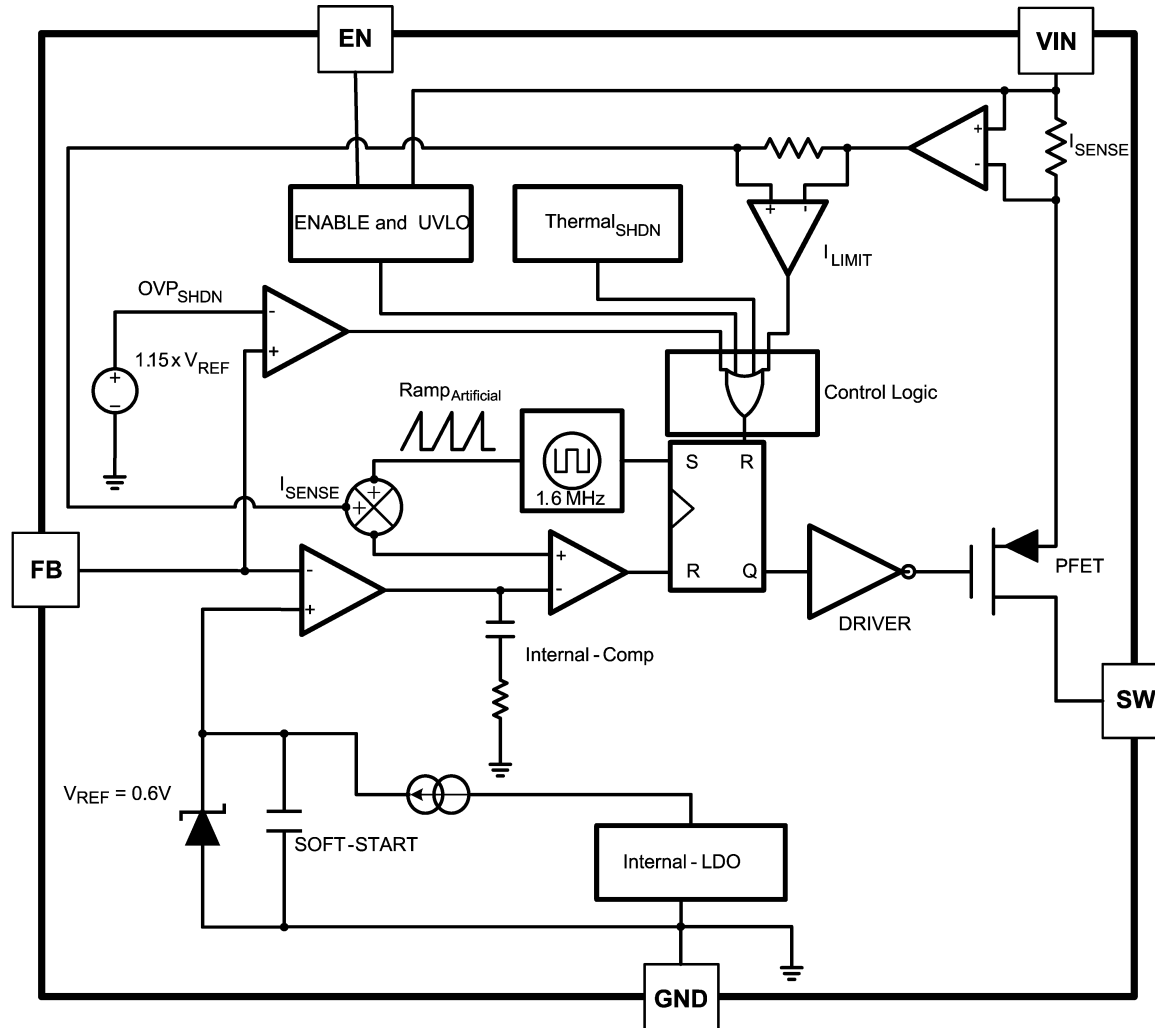

20197404

FIGURE 1.

Applications Information

THEORY OF OPERATION

The LM2830 is a constant frequency PWM buck regulator IC that delivers a 1.0A load current. The regulator has a preset switching frequency of 1.6MHz or 3.0MHz. This high frequency allows the LM2830 to operate with small surface mount capacitors and inductors, resulting in a DC/DC converter that requires a minimum amount of board space. The LM2830 is internally compensated, so it is simple to use and requires few external components. The LM2830 uses current-mode control to regulate the output voltage. The following operating description of the LM2830 will refer to the Simplified Block Diagram (Figure 1) and to the waveforms in Figure 2. The LM2830 supplies a regulated output voltage by switching the internal PMOS control switch at constant frequency and variable duty cycle. A switching cycle begins at the falling edge of the reset pulse generated by the internal oscillator. When this pulse goes low, the output control logic turns on the internal PMOS control switch. During this on-time, the SW pin voltage (V_{SW}) swings up to approximately V_{IN} , and the inductor current (I_L) increases with a linear slope. I_L is measured by the current sense amplifier, which generates an output proportional to the switch current. The sense signal is summed with the regulator's corrective ramp and compared to the error amplifier's output, which is proportional to the difference between the feedback voltage and V_{REF} . When the PWM comparator output goes high, the output switch turns off until the next switching cycle begins. During the switch off-time, inductor current discharges through the Schottky catch diode, which forces the SW pin to swing below ground by the forward voltage (V_D) of the Schottky catch diode. The regulator loop adjusts the duty cycle (D) to maintain a constant output voltage.

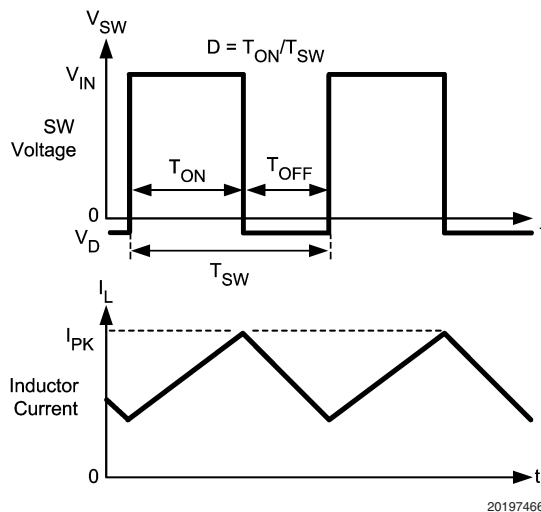

FIGURE 2. Typical Waveforms

SOFT-START

This function forces V_{OUT} to increase at a controlled rate during start up. During soft-start, the error amplifier's reference voltage ramps from 0V to its nominal value of 0.6V in approximately 600 μ s. This forces the regulator output to ramp up in a controlled fashion, which helps reduce inrush current.

OUTPUT OVERVOLTAGE PROTECTION

The over-voltage comparator compares the FB pin voltage to a voltage that is 15% higher than the internal reference V_{REF} . Once the FB pin voltage goes 15% above the internal reference, the internal PMOS control switch is turned off, which allows the output voltage to decrease toward regulation.

UNDERVOLTAGE LOCKOUT

Under-voltage lockout (UVLO) prevents the LM2830 from operating until the input voltage exceeds 2.73V (typ). The UVLO threshold has approximately 430 mV of hysteresis, so the part will operate until V_{IN} drops below 2.3V (typ). Hysteresis prevents the part from turning off during power up if V_{IN} is non-monotonic.

CURRENT LIMIT

The LM2830 uses cycle-by-cycle current limiting to protect the output switch. During each switching cycle, a current limit comparator detects if the output switch current exceeds 1.75A (typ), and turns off the switch until the next switching cycle begins.

THERMAL SHUTDOWN

Thermal shutdown limits total power dissipation by turning off the output switch when the IC junction temperature exceeds 165°C. After thermal shutdown occurs, the output switch doesn't turn on until the junction temperature drops to approximately 150°C.

Design Guide

INDUCTOR SELECTION

The Duty Cycle (D) can be approximated quickly using the ratio of output voltage (V_O) to input voltage (V_{IN}):

$$D = \frac{V_{OUT}}{V_{IN}}$$

The catch diode (D1) forward voltage drop and the voltage drop across the internal PMOS must be included to calculate a more accurate duty cycle. Calculate D by using the following formula:

$$D = \frac{V_{OUT} + V_D}{V_{IN} + V_D - V_{SW}}$$

V_{SW} can be approximated by:

$$V_{SW} = I_{OUT} \times R_{DSON}$$

The diode forward drop (V_D) can range from 0.3V to 0.7V depending on the quality of the diode. The lower the V_D , the higher the operating efficiency of the converter. The inductor value determines the output ripple current. Lower inductor values decrease the size of the inductor, but increase the output ripple current. An increase in the inductor value will decrease the output ripple current.

One must ensure that the minimum current limit (1.2A) is not exceeded, so the peak current in the inductor must be calculated. The peak current ($I_{L(PK)}$) in the inductor is calculated by:

$$I_{L(PK)} = I_{OUT} + \Delta I_L$$

Design Guide (Continued)

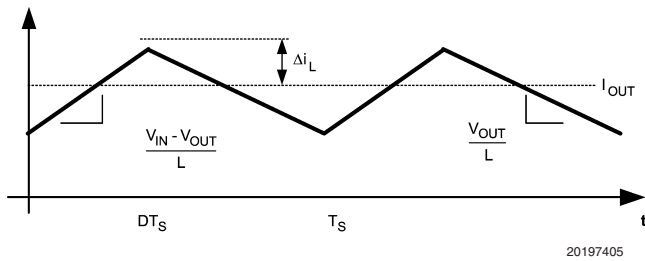

FIGURE 3. Inductor Current

$$\frac{V_{IN} - V_{OUT}}{L} = \frac{2\Delta i_L}{DT_s}$$

In general,

$$\Delta i_L = 0.1 \times (I_{OUT}) \rightarrow 0.2 \times (I_{OUT})$$

If $\Delta i_L = 20\%$ of 1A, the peak current in the inductor will be 1.2A. The minimum guaranteed current limit over all operating conditions is 1.2A. One can either reduce Δi_L , or make the engineering judgment that zero margin will be safe enough. The typical current limit is 1.75A.

The LM2830 operates at frequencies allowing the use of ceramic output capacitors without compromising transient response. Ceramic capacitors allow higher inductor ripple without significantly increasing output ripple. See the output capacitor section for more details on calculating output voltage ripple. Now that the ripple current is determined, the inductance is calculated by:

$$L = \left(\frac{DT_s}{2\Delta i_L} \right) \times (V_{IN} - V_{OUT})$$

Where

$$T_s = \frac{1}{f_s}$$

When selecting an inductor, make sure that it is capable of supporting the peak output current without saturating. Inductor saturation will result in a sudden reduction in inductance and prevent the regulator from operating correctly. Because of the speed of the internal current limit, the peak current of the inductor need only be specified for the required maximum output current. For example, if the designed maximum output current is 1.0A and the peak current is 1.25A, then the inductor should be specified with a saturation current limit of $> 1.25A$. There is no need to specify the saturation or peak current of the inductor at the 1.75A typical switch current limit. The difference in inductor size is a factor of 5. Because of the operating frequency of the LM2830, ferrite based inductors are preferred to minimize core losses. This presents little restriction since the variety of ferrite-based inductors is huge. Lastly, inductors with lower series resistance (R_{DCR}) will provide better operating efficiency. For recommended inductors see Example Circuits.

INPUT CAPACITOR

An input capacitor is necessary to ensure that V_{IN} does not drop excessively during switching transients. The primary specifications of the input capacitor are capacitance, voltage, RMS current rating, and ESL (Equivalent Series Inductance). The recommended input capacitance is 22 μF . The input voltage rating is specifically stated by the capacitor manufacturer. Make sure to check any recommended deratings and also verify if there is any significant change in capacitance at the operating input voltage and the operating temperature. The input capacitor maximum RMS input current rating (I_{RMS-IN}) must be greater than:

$$I_{RMS_IN} \geq \sqrt{D \left[I_{OUT}^2 (1-D) + \frac{\Delta i^2}{3} \right]}$$

Neglecting inductor ripple simplifies the above equation to:

$$I_{RMS_IN} = I_{OUT} \times \sqrt{D(1-D)}$$

It can be shown from the above equation that maximum RMS capacitor current occurs when $D = 0.5$. Always calculate the RMS at the point where the duty cycle D is closest to 0.5. The ESL of an input capacitor is usually determined by the effective cross sectional area of the current path. A large leaded capacitor will have high ESL and a 0805 ceramic chip capacitor will have very low ESL. At the operating frequencies of the LM2830, leaded capacitors may have an ESL so large that the resulting impedance ($2\pi fL$) will be higher than that required to provide stable operation. As a result, surface mount capacitors are strongly recommended.

Sanyo POSCAP, Tantalum or Niobium, Panasonic SP, and multilayer ceramic capacitors (MLCC) are all good choices for both input and output capacitors and have very low ESL. For MLCCs it is recommended to use X7R or X5R type capacitors due to their tolerance and temperature characteristics. Consult capacitor manufacturer datasheets to see how rated capacitance varies over operating conditions.

OUTPUT CAPACITOR

The output capacitor is selected based upon the desired output ripple and transient response. The initial current of a load transient is provided mainly by the output capacitor. The output ripple of the converter is:

$$\Delta V_{OUT} = \Delta i_L \left(R_{ESR} + \frac{1}{8 \times F_{SW} \times C_{OUT}} \right)$$

When using MLCCs, the ESR is typically so low that the capacitive ripple may dominate. When this occurs, the output ripple will be approximately sinusoidal and 90° phase shifted from the switching action. Given the availability and quality of MLCCs and the expected output voltage of designs using the LM2830, there is really no need to review any other capacitor technologies. Another benefit of ceramic capacitors is their ability to bypass high frequency noise. A certain amount of switching edge noise will couple through parasitic capacitances in the inductor to the output. A ceramic capacitor will bypass this noise while a tantalum will not. Since the output capacitor is one of the two external components that control the stability of the regulator control loop, most applications will require a minimum of 22 μF of output capacitance. Capacitance often, but not always, can be increased

Design Guide (Continued)

significantly with little detriment to the regulator stability. Like the input capacitor, recommended multilayer ceramic capacitors are X7R or X5R types.

CATCH DIODE

The catch diode (D1) conducts during the switch off-time. A Schottky diode is recommended for its fast switching times and low forward voltage drop. The catch diode should be chosen so that its current rating is greater than:

$$I_{D1} = I_{OUT} \times (1-D)$$

The reverse breakdown rating of the diode must be at least the maximum input voltage plus appropriate margin. To improve efficiency, choose a Schottky diode with a low forward voltage drop.

OUTPUT VOLTAGE

The output voltage is set using the following equation where R2 is connected between the FB pin and GND, and R1 is connected between V_O and the FB pin. A good value for R2 is 10kΩ. When designing a unity gain converter (V_o = 0.6V), R1 should be between 0Ω and 100Ω, and R2 should be equal or greater than 10kΩ.

$$R1 = \left(\frac{V_{OUT}}{V_{REF}} - 1 \right) \times R2$$

$$V_{REF} = 0.60V$$

PCB LAYOUT CONSIDERATIONS

When planning layout there are a few things to consider when trying to achieve a clean, regulated output. The most important consideration is the close coupling of the GND connections of the input capacitor and the catch diode D1. These ground ends should be close to one another and be connected to the GND plane with at least two through-holes. Place these components as close to the IC as possible. Next in importance is the location of the GND connection of the output capacitor, which should be near the GND connections of C_{IN} and D1. There should be a continuous ground plane on the bottom layer of a two-layer board except under the switching node island. The FB pin is a high impedance node and care should be taken to make the FB trace short to avoid noise pickup and inaccurate regulation. The feedback resistors should be placed as close as possible to the IC, with the GND of R1 placed as close as possible to the GND of the IC. The V_{OUT} trace to R2 should be routed away from the inductor and any other traces that are switching. High AC currents flow through the V_{IN}, SW and V_{OUT} traces, so they should be as short and wide as possible. However, making the traces wide increases radiated noise, so the designer must make this trade-off. Radiated noise can be decreased by choosing a shielded inductor. The remaining components should also be placed as close as possible to the IC. Please see Application Note AN-1229 for further considerations and the LM2830 demo board as an example of a four-layer layout.

Calculating Efficiency, and Junction Temperature

The complete LM2830 DC/DC converter efficiency can be calculated in the following manner.

$$\eta = \frac{P_{OUT}}{P_{IN}}$$

Or

$$\eta = \frac{P_{OUT}}{P_{OUT} + P_{LOSS}}$$

Calculations for determining the most significant power losses are shown below. Other losses totaling less than 2% are not discussed.

Power loss (P_{LOSS}) is the sum of two basic types of losses in the converter: switching and conduction. Conduction losses usually dominate at higher output loads, whereas switching losses remain relatively fixed and dominate at lower output loads. The first step in determining the losses is to calculate the duty cycle (D):

$$D = \frac{V_{OUT} + V_D}{V_{IN} + V_D - V_{SW}}$$

V_{SW} is the voltage drop across the internal PFET when it is on, and is equal to:

$$V_{SW} = I_{OUT} \times R_{DSON}$$

V_D is the forward voltage drop across the Schottky catch diode. It can be obtained from the diode manufacturer's Electrical Characteristics section. If the voltage drop across the inductor (V_{DCR}) is accounted for, the equation becomes:

$$D = \frac{V_{OUT} + V_D + V_{DCR}}{V_{IN} + V_D + V_{DCR} - V_{SW}}$$

The conduction losses in the free-wheeling Schottky diode are calculated as follows:

$$P_{DIODE} = V_D \times I_{OUT} \times (1-D)$$

Often this is the single most significant power loss in the circuit. Care should be taken to choose a Schottky diode that has a low forward voltage drop.

Another significant external power loss is the conduction loss in the output inductor. The equation can be simplified to:

$$P_{IND} = I_{OUT}^2 \times R_{DCR}$$

The LM2830 conduction loss is mainly associated with the internal PFET:

$$P_{COND} = (I_{OUT}^2 \times D) \left(1 + \frac{1}{3} \times \left(\frac{\Delta i_L}{I_{OUT}} \right)^2 \right) R_{DSON}$$

If the inductor ripple current is fairly small, the conduction losses can be simplified to:

$$P_{COND} = I_{OUT}^2 \times R_{DSON} \times D$$

Switching losses are also associated with the internal PFET. They occur during the switch on and off transition periods, where voltages and currents overlap resulting in power loss. The simplest means to determine this loss is to empirically measure the rise and fall times (10% to 90%) of the switch at the switch node.

Switching Power Loss is calculated as follows:

$$P_{SWR} = 1/2(V_{IN} \times I_{OUT} \times F_{SW} \times T_{RISE})$$

$$P_{SWF} = 1/2(V_{IN} \times I_{OUT} \times F_{SW} \times T_{FALL})$$

$$P_{SW} = P_{SWR} + P_{SWF}$$

Another loss is the power required for operation of the internal circuitry:

$$P_Q = I_Q \times V_{IN}$$

I_Q is the quiescent operating current, and is typically around 3.3mA for the 1.6MHz frequency option.

Typical Application power losses are:

Power Loss Tabulation

V_{IN}	5.0V		
V_{OUT}	3.3V	P_{OUT}	3.3W
I_{OUT}	1.0A		
V_D	0.45V	P_{DIODE}	150mW
F_{SW}	1.6MHz		
I_Q	3.3mA	P_Q	17mW
T_{RISE}	4nS	P_{SWR}	6mW
T_{FALL}	4nS	P_{SWF}	6mW
$R_{DS(ON)}$	150m Ω	P_{COND}	100mW
IND_{DCR}	70m Ω	P_{IND}	70mW
D	0.667	P_{LOSS}	345mW
η	88%	$P_{INTERNAL}$	125mW

$$\Sigma P_{COND} + P_{SW} + P_{DIODE} + P_{IND} + P_Q = P_{LOSS}$$

$$\Sigma P_{COND} + P_{SWF} + P_{SWR} + P_Q = P_{INTERNAL}$$

$$P_{INTERNAL} = 125mW$$

Thermal Definitions

T_J = Chip junction temperature

T_A = Ambient temperature

$R_{\theta JC}$ = Thermal resistance from chip junction to device case

$R_{\theta JA}$ = Thermal resistance from chip junction to ambient air

Heat in the LM2830 due to internal power dissipation is removed through conduction and/or convection.

Conduction: Heat transfer occurs through cross sectional areas of material. Depending on the material, the transfer of heat can be considered to have poor to good thermal conductivity properties (insulator vs. conductor).

Heat Transfer goes as:

Silicon \rightarrow package \rightarrow lead frame \rightarrow PCB

Convection: Heat transfer is by means of airflow. This could be from a fan or natural convection. Natural convection occurs when air currents rise from the hot device to cooler air.

Thermal impedance is defined as:

Thermal Definitions (Continued)

$$R_{\theta} = \frac{\Delta T}{\text{Power}}$$

Thermal impedance from the silicon junction to the ambient air is defined as:

$$R_{\theta JA} = \frac{T_J - T_A}{\text{Power}}$$

The PCB size, weight of copper used to route traces and ground plane, and number of layers within the PCB can greatly effect $R_{\theta JA}$. The type and number of thermal vias can also make a large difference in the thermal impedance. Thermal vias are necessary in most applications. They conduct heat from the surface of the PCB to the ground plane. Four to six thermal vias should be placed under the exposed pad to the ground plane if the LLP package is used.

Thermal impedance also depends on the thermal properties of the application operating conditions (V_{in} , V_o , I_o etc), and the surrounding circuitry.

Silicon Junction Temperature Determination Method 1:

To accurately measure the silicon temperature for a given application, two methods can be used. The first method requires the user to know the thermal impedance of the silicon junction to top case temperature.

Some clarification needs to be made before we go any further.

$R_{\theta JC}$ is the thermal impedance from all six sides of an IC package to silicon junction.

$R_{\phi JC}$ is the thermal impedance from top case to the silicon junction.

In this data sheet we will use $R_{\phi JC}$ so that it allows the user to measure top case temperature with a small thermocouple attached to the top case.

$R_{\phi JC}$ is approximately 30°C/Watt for the 6-pin LLP package with the exposed pad. Knowing the internal dissipation from the efficiency calculation given previously, and the case temperature, which can be empirically measured on the bench we have:

$$R_{\phi JC} = \frac{T_J - T_C}{\text{Power}}$$

Therefore:

$$T_J = (R_{\phi JC} \times P_{\text{LOSS}}) + T_C$$

From the previous example:

$$T_J = (R_{\phi JC} \times P_{\text{INTERNAL}}) + T_C$$

$$T_J = 30^{\circ}\text{C/W} \times 0.189\text{W} + T_C$$

The second method can give a very accurate silicon junction temperature.

The first step is to determine $R_{\theta JA}$ of the application. The LM2830 has over-temperature protection circuitry. When the silicon temperature reaches 165°C, the device stops switching. The protection circuitry has a hysteresis of about 15°C. Once the silicon temperature has decreased to approximately 150°C, the device will start to switch again. Knowing this, the $R_{\theta JA}$ for any application can be characterized during the early stages of the design one may calculate the $R_{\theta JA}$ by placing the PCB circuit into a thermal chamber. Raise the

ambient temperature in the given working application until the circuit enters thermal shutdown. If the SW-pin is monitored, it will be obvious when the internal PFET stops switching, indicating a junction temperature of 165°C. Knowing the internal power dissipation from the above methods, the junction temperature, and the ambient temperature $R_{\theta JA}$ can be determined.

$$R_{\theta JA} = \frac{165^{\circ} - T_a}{P_{\text{INTERNAL}}}$$

Once this is determined, the maximum ambient temperature allowed for a desired junction temperature can be found.

An example of calculating $R_{\theta JA}$ for an application using the National Semiconductor LM2830 LLP demonstration board is shown below.

The four layer PCB is constructed using FR4 with 1/2 oz copper traces. The copper ground plane is on the bottom layer. The ground plane is accessed by two vias. The board measures 3.0cm x 3.0cm. It was placed in an oven with no forced airflow. The ambient temperature was raised to 144°C, and at that temperature, the device went into thermal shutdown.

From the previous example:

$$P_{\text{INTERNAL}} = 189\text{mW}$$

$$R_{\theta JA} = \frac{165^{\circ}\text{C} - 144^{\circ}\text{C}}{189\text{ mW}} = 111^{\circ}\text{C/W}$$

If the junction temperature was to be kept below 125°C, then the ambient temperature could not go above 109°C

$$T_J - (R_{\theta JA} \times P_{\text{LOSS}}) = T_A$$

$$125^{\circ}\text{C} - (111^{\circ}\text{C/W} \times 189\text{mW}) = 104^{\circ}\text{C}$$

LLP Package

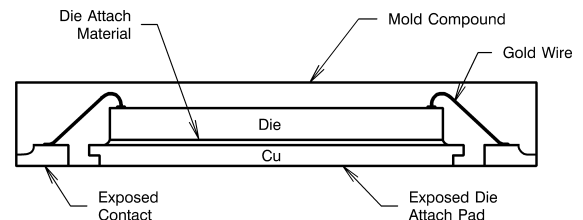

20197468

FIGURE 4. Internal LLP Connection

For certain high power applications, the PCB land may be modified to a "dog bone" shape (see Figure 6). By increasing the size of ground plane, and adding thermal vias, the $R_{\theta JA}$ for the application can be reduced.

LLP Package (Continued)

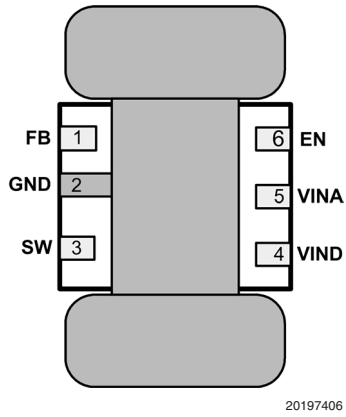
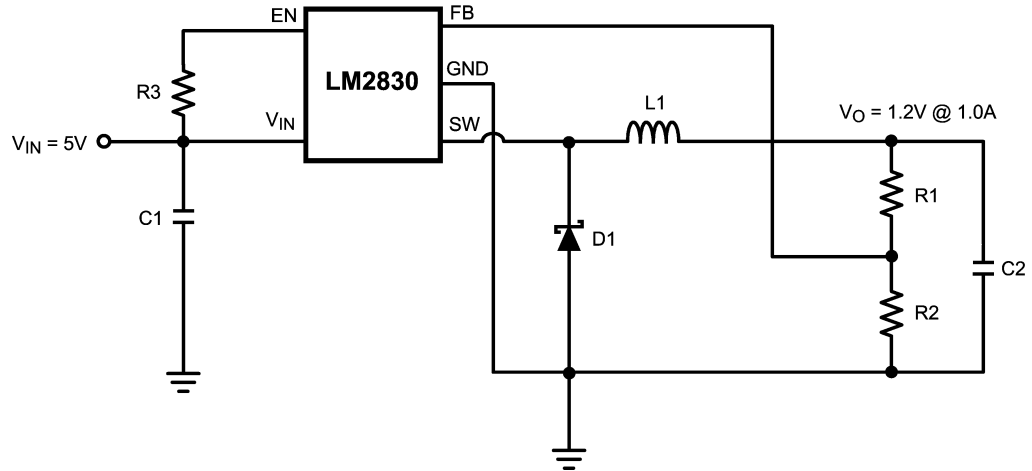

FIGURE 5. 6-Lead LLP PCB Dog Bone Layout

LM2830X Design Example 1



20197407

FIGURE 6. LM2830X (1.6MHz): $V_{in} = 5V$, $V_o = 1.2V @ 1.0A$

Bill of Materials

Part ID	Part Value	Manufacturer	Part Number
U1	1.0A Buck Regulator	NSC	LM2830X
C1, Input Cap	22 μ F, 6.3V, X5R	TDK	C3216X5ROJ226M
C2, Output Cap	22 μ F, 6.3V, X5R	TDK	C3216X5ROJ226M
D1, Catch Diode	0.3V, Schottky 1.5A, 30V _R	TOSHIBA	CRS08
L1	3.3 μ H, 1.3A	Coilcraft	ME3220-332
R2	15.0k Ω , 1%	Vishay	CRCW08051502F
R1	15.0k Ω , 1%	Vishay	CRCW08051502F
R3	100k Ω , 1%	Vishay	CRCW08051003F

LM2830X Design Example 2

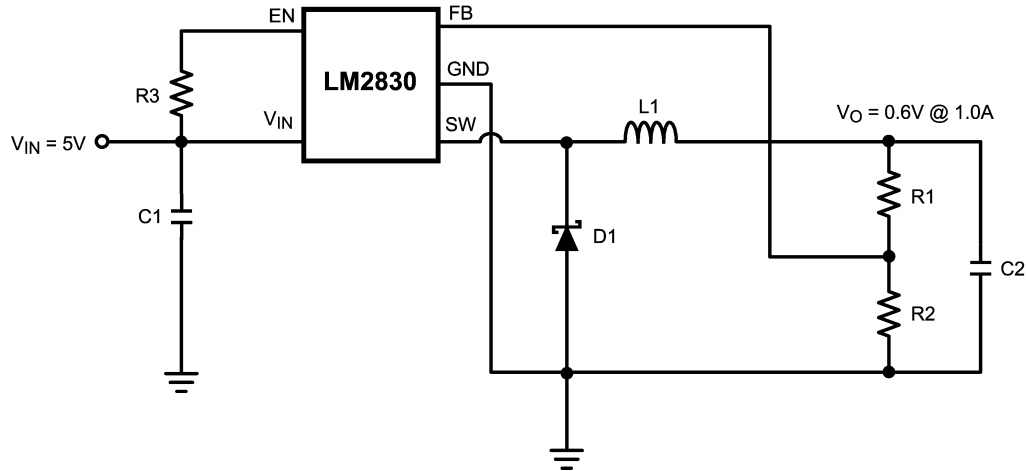

20197460

FIGURE 7. LM2830X (1.6MHz): $V_{in} = 5V$, $V_o = 0.6V @ 1.0A$

Bill of Materials

Part ID	Part Value	Manufacturer	Part Number
U1	1.0A Buck Regulator	NSC	LM2830X
C1, Input Cap	22 μ F, 6.3V, X5R	TDK	C3216X5ROJ226M
C2, Output Cap	22 μ F, 6.3V, X5R	TDK	C3216X5ROJ226M
D1, Catch Diode	0.3V _f Schottky 1.5A, 30V _R	TOSHIBA	CRS08
L1	3.3 μ H, 1.3A	Coilcraft	ME3220-332
R2	10.0k Ω , 1%	Vishay	CRCW08051000F
R1	0 Ω		
R3	100k Ω , 1%	Vishay	CRCW08051003F

LM2830X Design Example 3

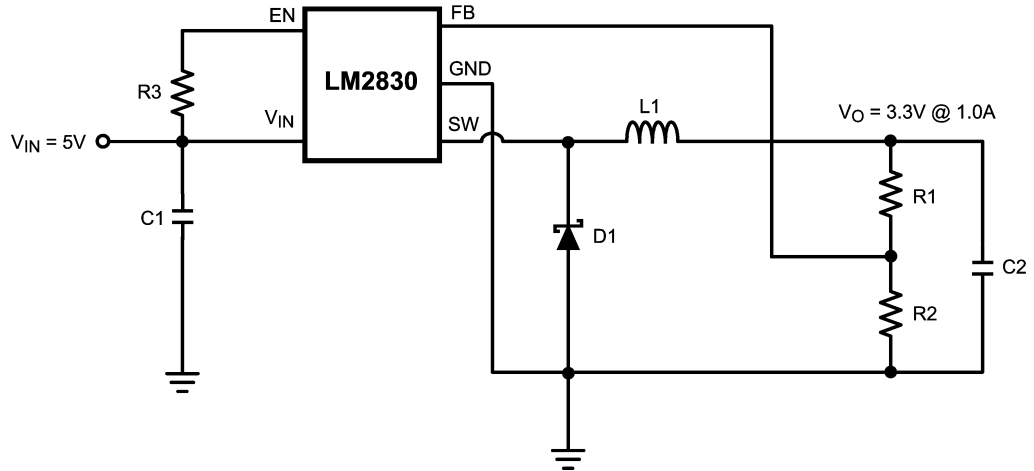

20197408

FIGURE 8. LM2830X (1.6MHz): $V_{in} = 5V$, $V_o = 3.3V @ 1.0A$

Bill of Materials

Part ID	Part Value	Manufacturer	Part Number
U1	1.0A Buck Regulator	NSC	LM2830X
C1, Input Cap	22 μ F, 6.3V, X5R	TDK	C3216X5ROJ226M
C2, Output Cap	22 μ F, 6.3V, X5R	TDK	C3216X5ROJ226M
D1, Catch Diode	0.3V, Schottky 1.5A, 30V _R	TOSHIBA	CRS08
L1	2.2 μ H, 1.8A	Coilcraft	ME3220-222
R2	10.0k Ω , 1%	Vishay	CRCW08051002F
R1	45.3k Ω , 1%	Vishay	CRCW08054532F
R3	100k Ω , 1%	Vishay	CRCW08051003F

LM2830Z Design Example 4

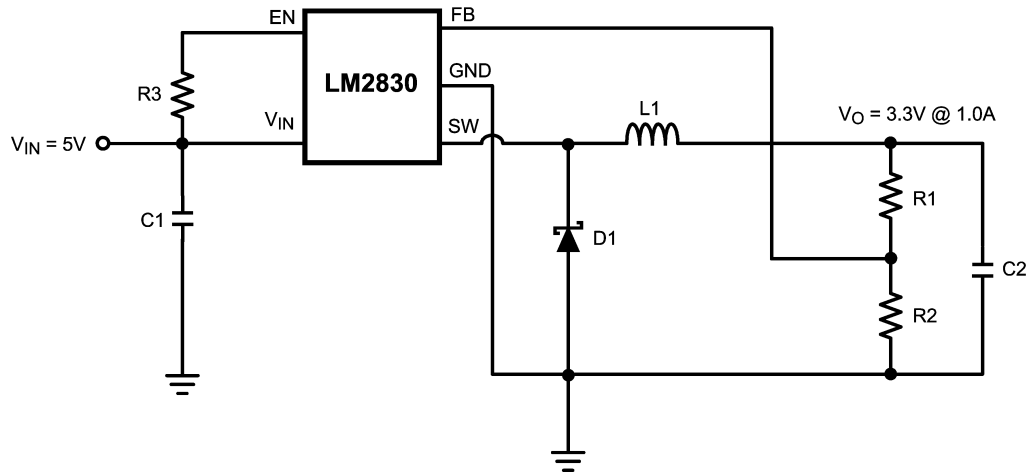

20197408

FIGURE 9. LM2830Z (3MHz): $V_{in} = 5V$, $V_o = 3.3V @ 1.0A$

Bill of Materials

Part ID	Part Value	Manufacturer	Part Number
U1	1.0A Buck Regulator	NSC	LM2830Z
C1, Input Cap	22 μ F, 6.3V, X5R	TDK	C3216X5ROJ226M
C2, Output Cap	22 μ F, 6.3V, X5R	TDK	C3216X5ROJ226M
D1, Catch Diode	0.3V _f Schottky 1.5A, 30V _R	TOSHIBA	CRS08
L1	1.6 μ H, 2.0A	TDK	VLCF4018T-1R6N1R7-2
R2	10.0k Ω , 1%	Vishay	CRCW08051002F
R1	45.3k Ω , 1%	Vishay	CRCW08054532F
R3	100k Ω , 1%	Vishay	CRCW08051003F

LM2830Z Design Example 5

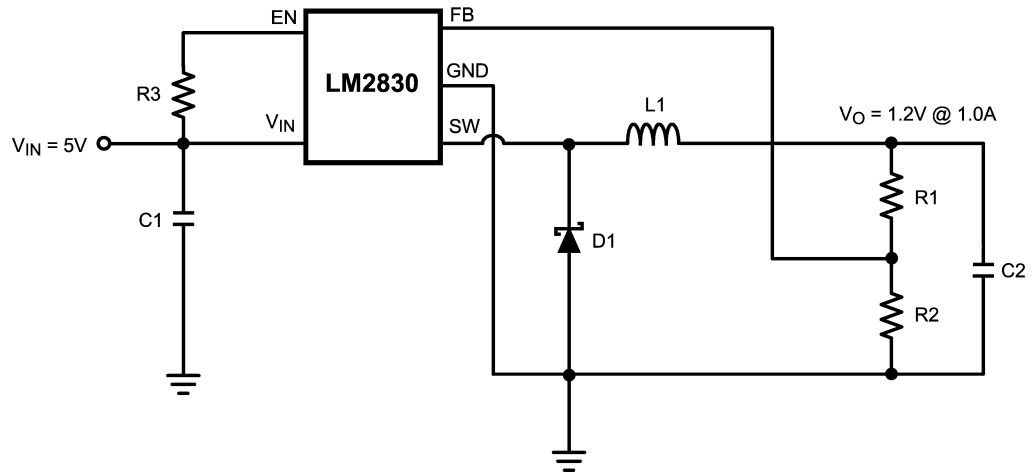

20197407

FIGURE 10. LM2830Z (3MHz): $V_{in} = 5V$, $V_o = 1.2V @ 1.0A$

Bill of Materials

Part ID	Part Value	Manufacturer	Part Number
U1	1.0A Buck Regulator	NSC	LM2830Z
C1, Input Cap	22 μ F, 6.3V, X5R	TDK	C3216X5ROJ226M
C2, Output Cap	22 μ F, 6.3V, X5R	TDK	C3216X5ROJ226M
D1, Catch Diode	0.3V _f Schottky 1.5A, 30V _R	TOSHIBA	CRS08
L1	1.6 μ H, 2.0A	TDK	VLCF4018T-1R6N1R7-2
R2	10.0k Ω , 1%	Vishay	CRCW08051002F
R1	10.0k Ω , 1%	Vishay	CRCW08051002F
R3	100k Ω , 1%	Vishay	CRCW08051003F

LM2830X Dual Converters with Delayed Enabled Design Example 6

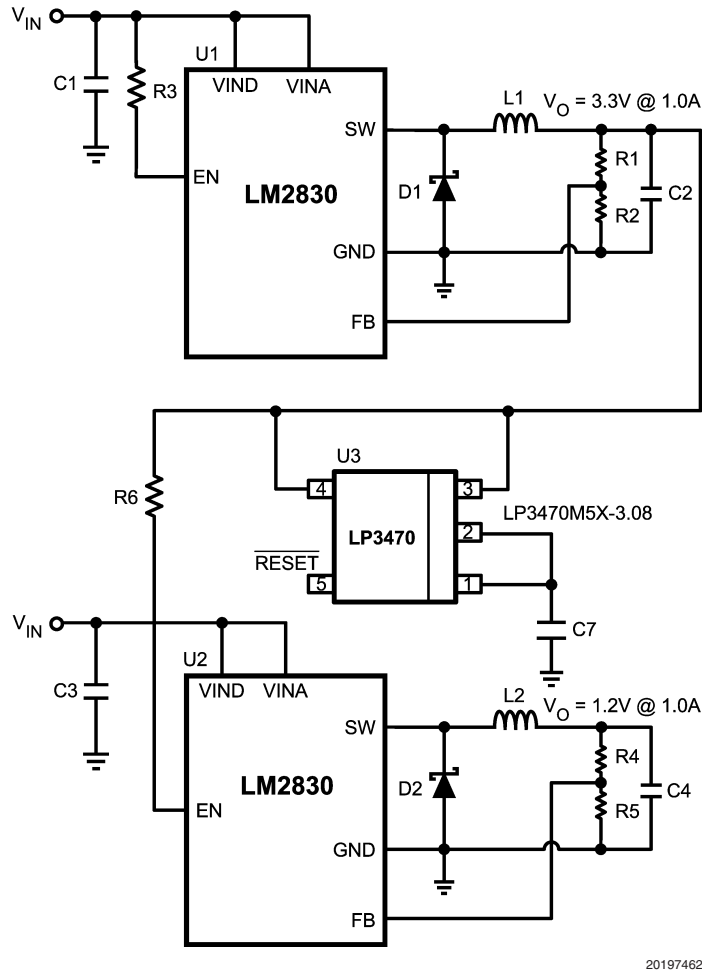

20197462

FIGURE 11. LM2830X (1.6MHz): $V_{in} = 5V$, $V_o = 1.2V @ 1.0A$ & $3.3V @ 1.0A$

Bill of Materials

Part ID	Part Value	Manufacturer	Part Number
U1, U2	1.0A Buck Regulator	NSC	LM2830X
U3	Power on Reset	NSC	LP3470M5X-3.08
C1, C3 Input Cap	22 μ F, 6.3V, X5R	TDK	C3216X5ROJ226M
C2, C4 Output Cap	22 μ F, 6.3V, X5R	TDK	C3216X5ROJ226M
C7	Trr delay capacitor	TDK	
D1, D2 Catch Diode	0.3V _f Schottky 1.5A, 30V _R	TOSHIBA	CRS08
L1, L2	3.3 μ H, 1.3A	Coilcraft	ME3220-332
R2, R4, R5	10.0k Ω , 1%	Vishay	CRCW08051002F
R1, R6	45.3k Ω , 1%	Vishay	CRCW08054532F
R3	100k Ω , 1%	Vishay	CRCW08051003F

LM2830X Buck Converter & Voltage Double Circuit with LDO Follower Design Example 7

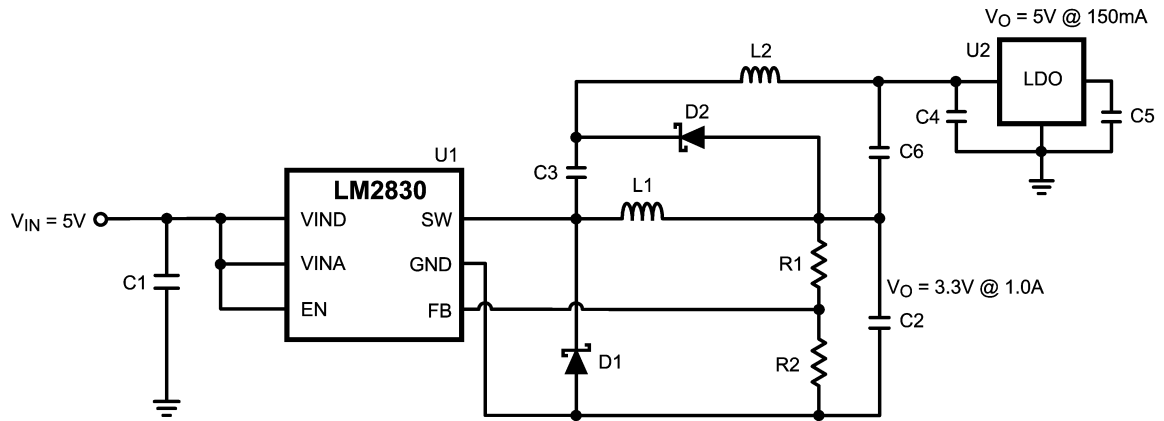

20197463

FIGURE 12. LM2830X (1.6MHz): $V_{in} = 5V$, $V_o = 3.3V @ 1.0A$ & LP2986-5.0 @ 150mA

Bill of Materials

Part ID	Part Value	Manufacturer	Part Number
U1	1.0A Buck Regulator	NSC	LM2830X
U2	200mA LDO	NSC	LP2986-5.0
C1, Input Cap	22 μ F, 6.3V, X5R	TDK	C3216X5ROJ226M
C2, Output Cap	22 μ F, 6.3V, X5R	TDK	C3216X5ROJ226M
C3 – C6	2.2 μ F, 6.3V, X5R	TDK	C1608X5R0J225M
D1, Catch Diode	0.3V _f Schottky 1.5A, 30V _R	TOSHIBA	CRS08
D2	0.4V _f Schottky 20V _R , 500mA	ON Semi	MBR0520
L2	10 μ H, 800mA	CoilCraft	ME3220-103
L1	3.3 μ H, 2.2A	TDK	VLCF5020T-3R3N2R0-1
R2	45.3k Ω , 1%	Vishay	CRCW08054532F
R1	10.0k Ω , 1%	Vishay	CRCW08051002F

Physical Dimensions inches (millimeters) unless otherwise noted

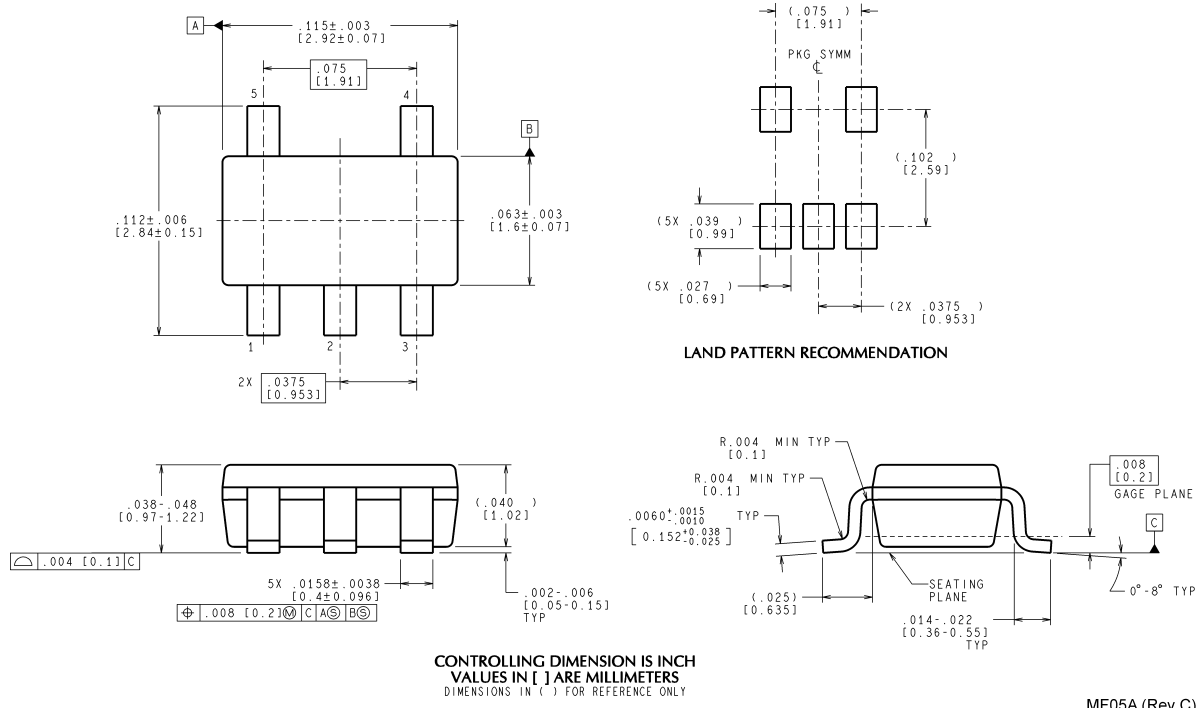

MF05A (Rev C)

5-Lead SOT-23 Package
NS Package Number MF05A

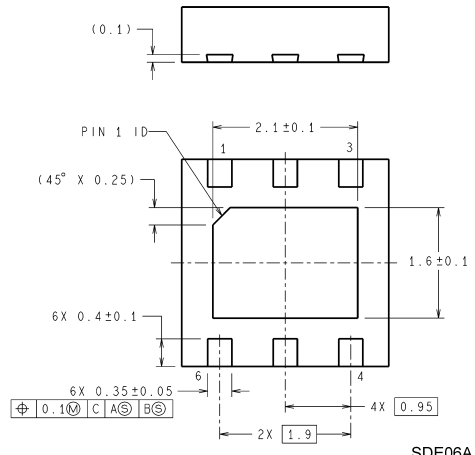
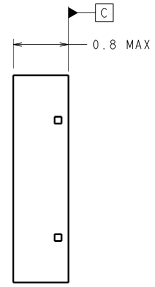
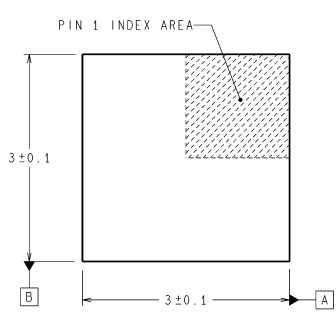
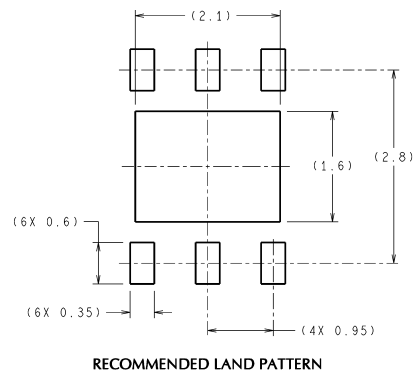

SDE06A (Rev A)

6-Lead LLP Package
NS Package Number SDE06A

Notes

National does not assume any responsibility for use of any circuitry described, no circuit patent licenses are implied and National reserves the right at any time without notice to change said circuitry and specifications.

For the most current product information visit us at www.national.com.

LIFE SUPPORT POLICY

NATIONAL'S PRODUCTS ARE NOT AUTHORIZED FOR USE AS CRITICAL COMPONENTS IN LIFE SUPPORT DEVICES OR SYSTEMS WITHOUT THE EXPRESS WRITTEN APPROVAL OF THE PRESIDENT AND GENERAL COUNSEL OF NATIONAL SEMICONDUCTOR CORPORATION. As used herein:

1. Life support devices or systems are devices or systems which, (a) are intended for surgical implant into the body, or (b) support or sustain life, and whose failure to perform when properly used in accordance with instructions for use provided in the labeling, can be reasonably expected to result in a significant injury to the user.
2. A critical component is any component of a life support device or system whose failure to perform can be reasonably expected to cause the failure of the life support device or system, or to affect its safety or effectiveness.

BANNED SUBSTANCE COMPLIANCE

National Semiconductor follows the provisions of the Product Stewardship Guide for Customers (CSP-9-111C2) and Banned Substances and Materials of Interest Specification (CSP-9-111S2) for regulatory environmental compliance. Details may be found at: www.national.com/quality/green.

Lead free products are RoHS compliant.



National Semiconductor
Americas Customer
Support Center
Email: new.feedback@nsc.com
Tel: 1-800-272-9959

www.national.com

National Semiconductor
Europe Customer Support Center
Fax: +49 (0) 180-530 85 86
Email: europa.support@nsc.com
Deutsch Tel: +49 (0) 69 9508 6208
English Tel: +44 (0) 870 24 0 2171
Français Tel: +33 (0) 1 41 91 8790

National Semiconductor
Asia Pacific Customer
Support Center
Email: ap.support@nsc.com

National Semiconductor
Japan Customer Support Center
Fax: 81-3-5639-7507
Email: jpn.feedback@nsc.com
Tel: 81-3-5639-7560