



### FEATURES

**Wide Input Range, Resistor Programmable**  
**Pin Programmable Output: 4 to 20mA or 0 to 20mA**  
**High CMV Input/Output Isolation:  $\pm 1500V$  pk**  
**Continuous**

**Low Nonlinearity:  $\pm 0.05\%$  max (2B23K)**  
**Low Span Drift:  $\pm 0.005\%/^{\circ}C$  max (2B23K)**  
**Single Supply Operation: +14V to +28V**  
**Small Size: 1.8"  $\times$  2.4"  $\times$  0.6"**  
**Meets IEEE Std. 472: Transient Protection (SWC)**  
**Meets ISA Std. 50.1: Isolated Current Loop Transmitters**

### APPLICATIONS

**Industrial Instrumentation and Process Control**  
**Ground Loop Elimination**  
**Transient Voltage Protection**  
**Analog Transmitters and Controllers**  
**Remote Data Acquisition Systems**

### GENERAL DESCRIPTION

The model 2B23 is a high performance, low cost voltage to current converter featuring  $\pm 1500V$  pk input to output isolation for interfacing with standard process signals. The input stage of the 2B23 may be single resistor programmed to accept voltages within a 0 to +10V range (+0.1V to +10V full scale). The isolated output is pin programmable to provide current in the range of 4 to 20mA or 0 to 20mA and can be operated with 0 to 800 $\Omega$  grounded or floating loads.

The 2B23 uses reliable transformer isolation techniques and is available in two accuracy selections offering guaranteed non-linearity error (2B23K:  $\pm 0.05\%$  max, 2B23J:  $\pm 0.1\%$  max) and guaranteed low span drift (2B23K:  $\pm 0.005\%/^{\circ}C$  max, 2B23J:  $\pm 0.01\%/^{\circ}C$  max). The internally trimmed span and offset errors are  $\pm 0.1\%$  for the 2B23K and  $\pm 0.25\%$  for the 2B23J. Both span and offset may be adjusted using optional external potentiometers.

Featuring wide range, single supply operation (+14V to +28V dc), the 2B23 provides isolated loop power, thus eliminating the need for an external dc/dc converter.

### APPLICATIONS

Model 2B23 has been designed to provide high accuracy, versatility and low cost in industrial and laboratory system applications requiring isolated current transmission. The 2B23 meets the requirements of the Instrument Society of America Std. 50.1 "Compatibility of Analog Signals for Electronic Industrial Process Instruments" and may serve as a transmission link between such system elements as computers, controllers, actuators, recorders and indicators.

### FUNCTIONAL BLOCK DIAGRAM

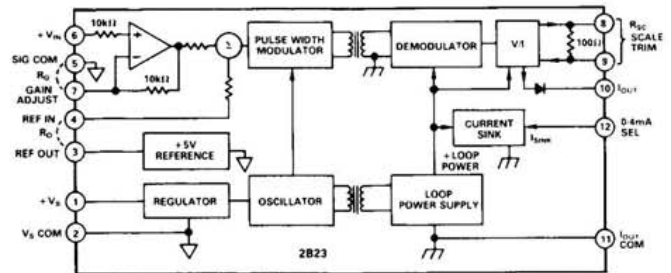

In data acquisition and control systems, the 2B23 may act as an isolated interface between the D/A converter output of a micro-computer analog I/O and standard 4 to 20mA or 0 to 20mA analog loops. In process control systems, the 2B23 may be used as a current output stage of a proportional controller to interface devices such as current-to-position converters and current-to-pneumatic transducers.

### DESIGN FEATURES AND USER BENEFITS

**High CMV Isolation:** The 2B23 features high input to output galvanic isolation to eliminate ground loops and offer protection against damage from transients and fault voltages. Its isolation barrier will withstand continuous CMV of  $\pm 1500V$  pk and 1500V rms @ 60Hz for 60 seconds.

**High Reliability:** To assure high reliability in harsh industrial environments, reliable magnetic isolation is used. The 2B23 meets the IEEE Standard for Transient Voltage Protection (472-1974: Surge Withstand Capability) and offers reliable operation over  $-25^{\circ}C$  to  $+85^{\circ}C$  temperature range.

**Versatility:** The 2B23 can be easily tailored to the user's application, accommodating a wide range of input voltages, providing pin programmable, standard current outputs and offering wide range, single supply operation.

**Small Size:** To conserve board space, the 2B23 is packaged in a compact, 1.8"  $\times$  2.4"  $\times$  0.6" module.

REV. A

1400 PROVIDENCE HIGHWAY • BUILDING 2 NORWOOD, MASSACHUSETTS 02062-5015  
 PHONE: 781-551-5500 FAX: 781-551-5555

# 2B23—SPECIFICATIONS (typical @ +25°C and $V_S = \pm 15V$ unless otherwise noted)

Model	2B23J	2B23K
<b>INPUT SPECIFICATIONS</b>		
Input Voltage Range	0 to +10V	*
Factory Calibrated Full Scale Input	+0.1V min to +10V max	*
Transfer Function (TF)		
Factory Calibrated	1.6mA/V	*
User Programmable	1.6mA/V to 200mA/V	*
Maximum Safe Input	$\pm 15V$	*
Input Impedance	10M $\Omega$	*
<b>OUTPUT SPECIFICATIONS</b>		
Current Output Range		
User Selectable	4 to 20mA, 0 to 20mA	*
Load Resistance Range		
Internal Loop Power	0 to 800 $\Omega$ max	*
Maximum Output Current		
@ Input Overload	22mA typ	*
Output Noise		
100Hz Bandwidth	1.5 $\mu$ A pk-pk	*
<b>NONLINEARITY</b>		
	$\pm 0.1\%$ max	$\pm 0.05\%$ max ( $\pm 0.02\%$ typ)
<b>ISOLATION</b>		
CMV, Input to Output		
ac, 60Hz, 1 min	1500V rms	*
Continuous, ac or dc	$\pm 1500V$ pk	*
Transient Protection	IEEE Std. 472 (SWC)	*
CMR		
@ 60Hz, 1k $\Omega$ Source Imbalance	86dB	*
<b>ACCURACY<sup>1</sup></b>		
Warm Up Time to Rated Performance		
	5 Minutes	*
Total Output Error @ +25°C <sup>2,3</sup>		
Offset ( $V_{IN} = 0V$ )	$\pm 0.25\%$ max	$\pm 0.1\%$ max
Span ( $V_{IN} = +10V$ )	$\pm 0.25\%$ max	$\pm 0.1\%$ max
vs. Temperature (0 to +70°C)		
Offset, 4-20mA Mode	$\pm 0.01\%/^{\circ}C$ max	$\pm 0.005\%/^{\circ}C$ max
0-20mA Mode	$\pm 0.01\%/^{\circ}C$ typ	$\pm 0.005\%/^{\circ}C$ typ
Span, Both Modes	$\pm 0.01\%/^{\circ}C$ max	$\pm 0.005\%/^{\circ}C$ max
<b>DYNAMIC RESPONSE</b>		
Settling Time to 0.1% of FS for 10V Step	5ms	*
Small Signal Bandwidth	400Hz	*
<b>POWER SUPPLY</b>		
Voltage, Rated Performance (+ $V_S$ )	+15V dc	*
Voltage, Operating	+14V min to +28V max	*
Supply Current (@ 20mA Output)	75mA	*
Supply Change Effect on Offset and Span	$\pm 0.0015\%/V$	*
<b>ENVIRONMENTAL</b>		
Temperature Range		
Rated Performance	0 to +70°C	*
Operating	-25°C to +85°C	*
Relative Humidity		
per MIL-STD 202, Method 103B	$\pm 0.2\%$ Error	*
RFI Immunity		
27MHz @ 5W @ 3ft	$\pm 0.1\%$ Error	*
<b>CASE SIZE</b>		
	1.8" x 2.4" x 0.6"	*

## NOTES

<sup>1</sup>Accuracy is guaranteed @ TF = 1.6mA/V with no external trim adjustments when connected in the basic configuration.

<sup>2</sup>All accuracy is % of span where span is 16mA (i.e.,  $\pm 0.1\% = 0.016mA$  error).

<sup>3</sup>Span T.C. for transfer functions higher than 1.6mA/V is  $R_G$  dependent - low T.C. ( $\pm 10ppm/^{\circ}C$ )  $R_G$  recommended for best performance.

\*Specifications same as 2B23J.

Specifications subject to change without notice.

## OUTLINE DIMENSIONS

Dimensions shown in inches and (mm).

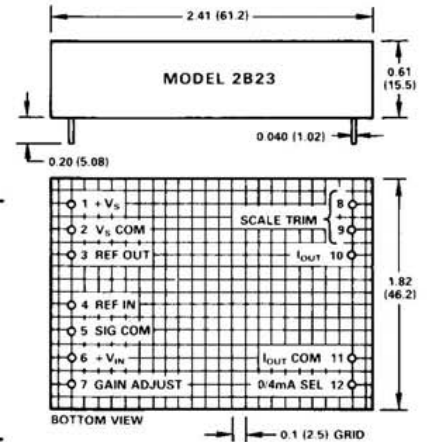

## MATING SOCKET: AC1586

Dimensions shown in inches and (mm).

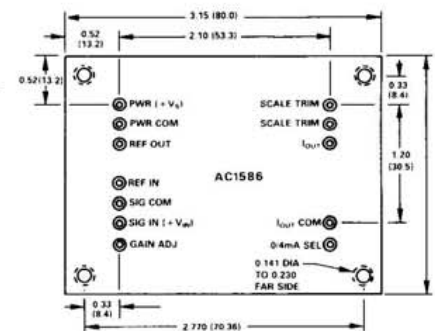

## FUNCTIONAL DESCRIPTION

The high performance of model 2B23 is derived from the carrier isolation technique which is used to transfer both signal and power between the V/I converter's input circuitry and the output stage. High CMV isolation is achieved by the transformer coupling between the input amplifier stage, modulator, and current output circuitry. A block diagram of the 2B23 is shown in Figure 1.

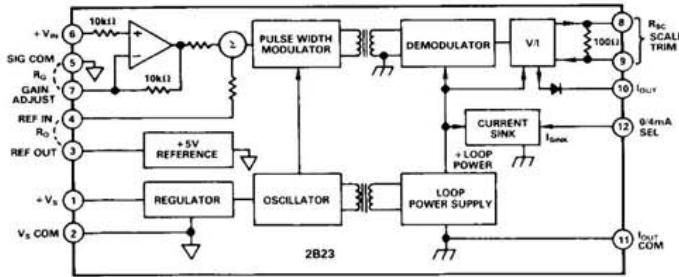

Figure 1. 2B23 Functional Block Diagram

The model 2B23 produces an isolated 4 to 20mA or 0 to 20mA output current which is proportional to the input voltage and independent of the output load resistance. The input amplifier accepts a positive voltage within the range of 0 to +10V. The transfer function of the input stage may be set from 1.6mA/V to 200mA/V (dependent upon the output current range desired) by changing the gain resistor  $R_G$  connected between pins 5 and 7.

An internal, high stability reference having a nominal output voltage of +5V (REF OUT) is used to develop a 4mA output current for a 0 volts input. REF OUT (Pin 3) and REF IN (Pin 4) should be connected via the offset scaling resistor  $R_O$ . An output current bypass section allows scaling of the nominal 4 to 20mA output current to a range of 0 to 20mA. This is accomplished by connecting the output range select pin (Pin 12) to the  $I_{OUT}$  pin (Pin 10) thereby providing a bypass for the 4mA. For 4-20mA operation, the bypass pin is connected to  $I_{OUT}$  COMMON (Pin 11).

The 2B23 is designed to operate from a single positive power supply ( $+V_S$ ) over a range of +14V to +28V dc. The power supply section consists of an input voltage regulator, a dc/dc converter, plus associated rectifying and filtering circuitry. The dc/dc converter generates isolated loop power which is independent of  $V_S$  and capable of driving the maximum load resistance (resistance of receivers plus the resistance of connecting wire) of 800 $\Omega$ . The current capability of the power supply ( $+V_S$ ) must be 75mA minimum to supply full output signal current.

## BASIC INTERCONNECTIONS

The 2B23 may be applied to achieve rated performance as shown in Figure 2. The transfer function of 1.6mA/V, for conversion of the 0 to +10V input signal into a 4 to 20mA output current, is obtained using the values shown ( $R_O = 10k\Omega$ ,  $R_{SC} = 301\Omega$ ,  $R_G$  open). For best performance,  $R_{SC}$  should be a metal film,  $\pm 0.1\%$  tolerance, 25ppm/ $^{\circ}C$  resistor and  $R_O$  should be  $\pm 1\%$ , 100ppm/ $^{\circ}C$ .

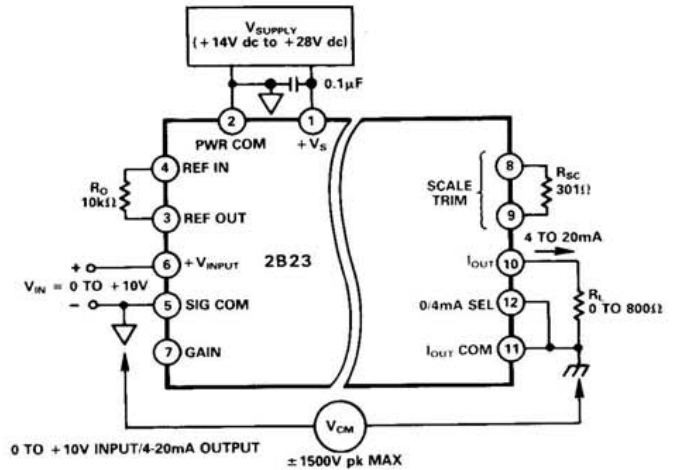

Figure 2. Basic Interconnections

A power supply ( $+V_S$ ) is connected to Pin 1. To avoid ground loops, the user should ensure that the input signal return (SIG COM) does not carry the power supply return current. Power common (Pin 2) and signal common (Pin 5) should be tied at the power supply common terminal.

## OPTIONAL TRIM ADJUSTMENTS

Model 2B23 is factory calibrated for a 0 to +10V input range and an output of 4 to 20mA, meeting its listed specifications without use of any external trim potentiometers. If desired, optional span and zero trim adjustments may be easily accomplished as described in the following sections.

**Input Gain Adjustment:** The input gain of the 2B23 is a scale factor setting that establishes the nominal conversion relationship to accommodate +1V to +10V full scale inputs ( $V_{IN}$ ). In addition, full scale inputs as low as 100mV may be accommodated.

The value of the gain setting resistor  $R_G$  is determined by:  $R_G$  (k $\Omega$ ) =  $10k\Omega / (G - 1)$  where G represents a ratio of  $10V / V_{IN}(V)$  F.S. For example, to convert a 0 to +1V input to 4 to 20mA output,  $V_{IN}$  F.S. = +1V and  $G = 10V / 1V = 10$ , therefore  $R_G = 10k\Omega / 9 = 1.1k\Omega$ . Due to resistor tolerances, allowance should be made to vary  $R_G$  by using a series cermet type potentiometer (Figure 3). For best performance,  $R_G$  should be a metal film, 1% tolerance, 25ppm/ $^{\circ}C$  resistor.

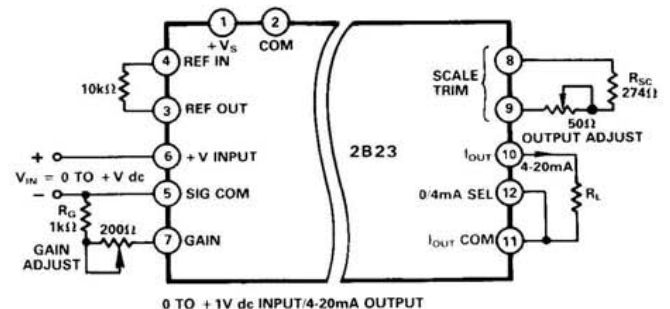
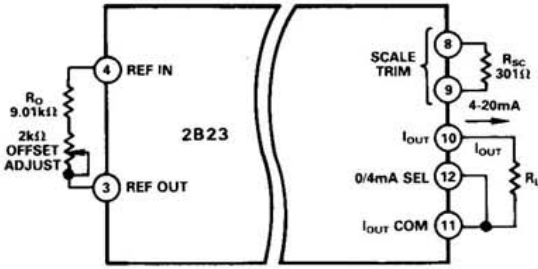

Figure 3. Input Gain Adjustment

# 2B23

**Offset and Output Scaling Adjustments:** After selecting the required input stage gain, the 2B23 must then be configured for either 4 to 20mA or 0 to 20mA output current range. Figures 4a and 4b illustrate the respective methods for each. The value of the offset resistor  $R_O$  is independent from the gain setting and may be adjusted by a series cermet pot.

For fine adjustment of the output current,  $R_{SC}$  value should be trimmed as shown in Figure 3.



4a. 4-20mA Output Connections

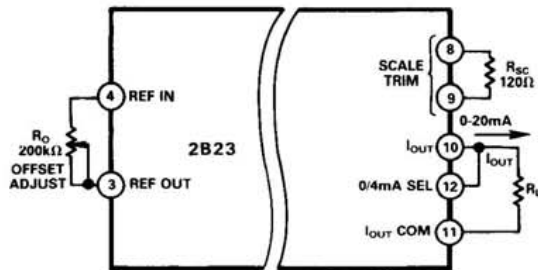

4b. 0-20mA Output Connections

Figure 4. 4-20mA/0-20mA Scaling Connections

## USING MULTIPLE 2B23s

Unlike other transformer-based isolators, the 2B23 does not require any synchronizing circuits to eliminate beat frequency related output errors in multichannel applications. This is due to the use of pulse-width modulation technique in the 2B23. Radiated individual oscillator frequencies will have no effect upon performance, even in situations requiring multiple 2B23s to be located in close proximity to one another. For this reason, no provisions for external synchronization are necessary.

## OUTPUT PROTECTION

The current output terminals (Pins 10 and 11) are protected for reverse voltage and shorts up to +32V dc but in many industrial applications it may be necessary to protect the 4 to 20mA from accidental shorts to ac line voltages. The circuit shown in Figure 5 may be employed for this purpose. The maximum permissible load resistance will be lowered by a fuse resistance value when protection circuitry is utilized.

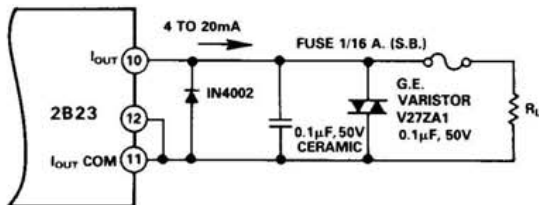

Figure 5. Output Protection Circuitry

## APPLICATIONS

In Figure 6, model 2B23 is used in multiloop application of the data acquisition and control system to provide isolated current interface to a recorder, indicator and a valve positioner.

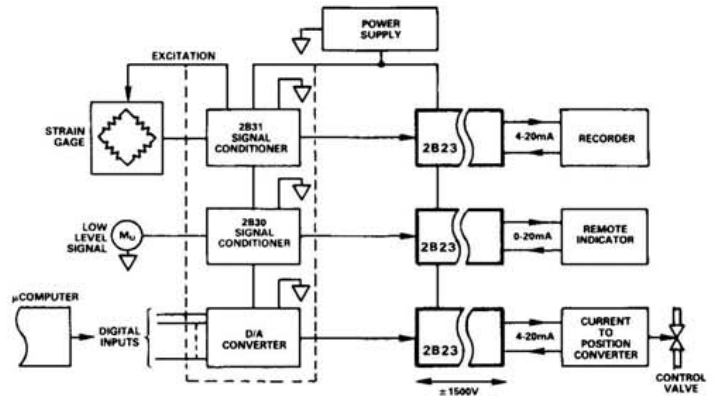

Figure 6. Multiloop Isolation

In applications requiring current to voltage conversion, the 2B23 may be used as shown in Figure 7. An external -10V reference is used to provide necessary input offset. This circuit will provide ±1500V isolation in converting 4-20mA into a 0 to +10V output. The output measurement device must have a high input impedance to avoid loading errors.

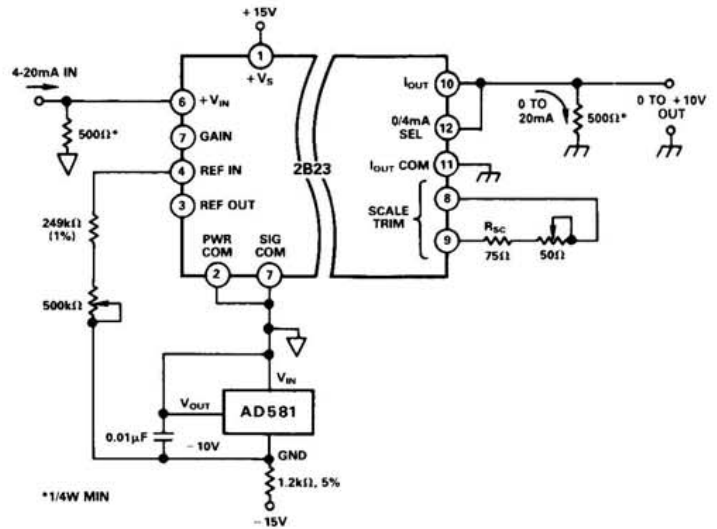

Figure 7. 4-20mA to 0 to +10V Isolated Converter