

C505

C505C

C505A

C505CA

8-Bit Single-Chip Microcontroller

8bit

Microcontrollers



Never stop thinking.

Edition 2000-12

**Published by Infineon Technologies AG,
St.-Martin-Strasse 53,
D-81541 München, Germany**

**© Infineon Technologies AG 2000.
All Rights Reserved.**

Attention please!

The information herein is given to describe certain components and shall not be considered as warranted characteristics.

Terms of delivery and rights to technical change reserved.

We hereby disclaim any and all warranties, including but not limited to warranties of non-infringement, regarding circuits, descriptions and charts stated herein.

Infineon Technologies is an approved CECC manufacturer.

Information

For further information on technology, delivery terms and conditions and prices please contact your nearest Infineon Technologies Office in Germany or our Infineon Technologies Representatives worldwide (see address list).

Warnings

Due to technical requirements components may contain dangerous substances. For information on the types in question please contact your nearest Infineon Technologies Office.

Infineon Technologies Components may only be used in life-support devices or systems with the express written approval of Infineon Technologies, if a failure of such components can reasonably be expected to cause the failure of that life-support device or system, or to affect the safety or effectiveness of that device or system. Life support devices or systems are intended to be implanted in the human body, or to support and/or maintain and sustain and/or protect human life. If they fail, it is reasonable to assume that the health of the user or other persons may be endangered.

C505

C505C

C505A

C505CA

8-Bit Single-Chip Microcontroller

Microcontrollers



Never stop thinking.

C505/C505C/C505A/C505CA Data Sheet		
Revision History :		Current Version : 2000-12
Previous Releases :		08.00, 06.00, 07.99, 12.97
Page (in previous version)	Page (in current version)	Subjects (major changes since last revision)
24	24	Version register VR2 for C505A-4R/C505CA-4R BB step is updated.

Controller Area Network (CAN): License of Robert Bosch GmbH

We Listen to Your Comments

Any information within this document that you feel is wrong, unclear or missing at all?
 Your feedback will help us to continuously improve the quality of this document.
 Please send your proposal (including a reference to this document) to:

mcdocu.comments@infineon.com



8-Bit Single-Chip Microcontroller C500 Family

**C505/C505C/C505A/
C505CA**

Advance Information

- Fully compatible to standard 8051 microcontroller
- Superset of the 8051 architecture with 8 datapointers
- Up to 20 MHz operating frequency
 - 375 ns instruction cycle time @16 MHz
 - 300 ns instruction cycle time @20 MHz (50 % duty cycle)
- On-chip program memory (with optional memory protection)
 - C505(C)(A)-2R : 16K byte on-chip ROM
 - C505A-4R/C505CA-4R: 32K byte on-chip ROM
 - C505A-4E/C505CA-4E: 32K byte on-chip OTP
 - alternatively up to 64k byte external program memory
- 256 byte on-chip RAM
- On-chip XRAM
 - C505/C505C : 256 byte
 - C505A/C505CA : 1K byte

(more features on next page)

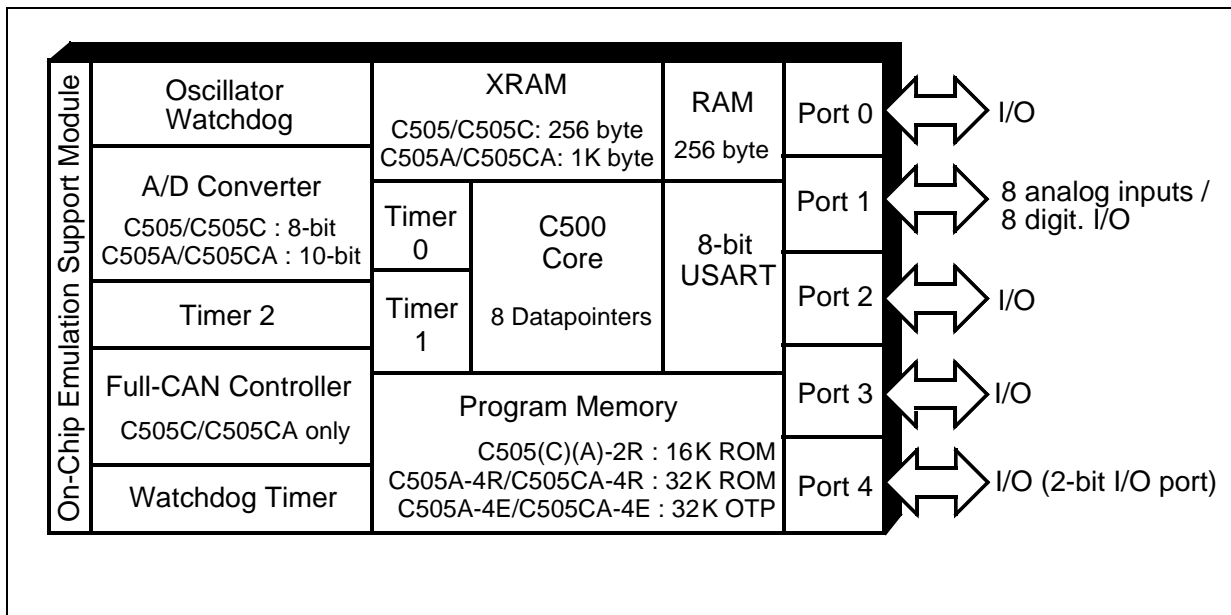

Figure 1
C505 Functional Units

Features (continued) :

- 32 + 2 digital I/O lines
 - Four 8-bit digital I/O ports
 - One 2-bit digital I/O port (port 4)
 - Port 1 with mixed analog/digital I/O capability
- Three 16-bit timers/counters
 - Timer 0 / 1 (C501 compatible)
 - Timer 2 with 4 channels for 16-bit capture/compare operation
- Full duplex serial interface with programmable baudrate generator (USART)
- Full CAN Module, version 2.0 B compliant (C505C and C505CA only)
 - 256 register/data bytes located in external data memory area
 - 1 MBaud CAN baudrate when operating frequency is equal to or above 8 MHz
 - internal CAN clock prescaler when input frequency is over 10 MHz
- On-chip A/D Converter
 - up to 8 analog inputs
 - C505/C505C : 8-bit resolution
 - C505A/C505CA: 10-bit resolution
- Twelve interrupt sources with four priority levels
- On-chip emulation support logic (Enhanced Hooks Technology™)
- Programmable 15-bit watchdog timer
- Oscillator watchdog
- Fast power on reset
- Power Saving Modes
 - Slow-down mode
 - Idle mode (can be combined with slow-down mode)
 - Software power-down mode with wake up capability through P3.2/ $\overline{\text{INT0}}$ or P4.1/RXDC pin
- P-MQFP-44 package
- Pin configuration is compatible to C501, C504, C511/C513-family
- Temperature ranges:

SAB-C505 versions	$T_A = 0 \text{ to } 70 \text{ }^\circ\text{C}$
SAF-C505 versions	$T_A = -40 \text{ to } 85^\circ\text{C}$
SAH-C505 versions	$T_A = -40 \text{ to } 110^\circ\text{C}$
SAK-C505 versions	$T_A = -40 \text{ to } 125^\circ\text{C}$

Table 1
Differences in Functionality of the C505 MCUs

Device	Internal Program Memory		XRAM Size	A/D Converter Resolution	CAN Controller
	ROM	OTP			
C505-2R	16K byte	–	256 byte	8 Bit	–
C505-L	–	–	256 byte	8 Bit	–
C505C-2R	16K byte	–	256 byte	8 Bit	√
C505C-L	–	–	256 byte	8 Bit	√
C505A-4R	32K byte	–	1K byte	10 Bit	–
C505A-2R	16K byte	–	1K byte	10 Bit	–
C505A-L	–	–	1K byte	10 Bit	–
C505CA-4R	32K byte	–	1K byte	10 Bit	√
C505CA-2R	16K byte	–	1K byte	10 Bit	√
C505CA-L	–	–	1K byte	10 Bit	√
C505A-4E	–	32K byte	1K byte	10 Bit	–
C505CA-4E	–	32K byte	1K byte	10 Bit	√

Note: The term C505 refers to all versions described within this document unless otherwise noted. However the term C505 may also be restricted by the context to refer to only CAN-less derivatives with 8-Bit ADC which are C505-2R and C505-L in this document.

Note: The term C505(C)(A)-2R, for simplicity, is used to stand for C505 16K byte ROM versions within this document which are C505-2R, C505C-2R, C505A-2R and C505CA-2R.

Ordering Information

The ordering code for Infineon Technologies' microcontrollers provides an exact reference to the required product. This ordering code identifies:

- the derivative itself, i.e. its function set
- the specified temperature range
- the package and the type of delivery

For the available ordering codes for the C505 please refer to the “**Product information Microcontrollers**”, which summarizes all available microcontroller variants.

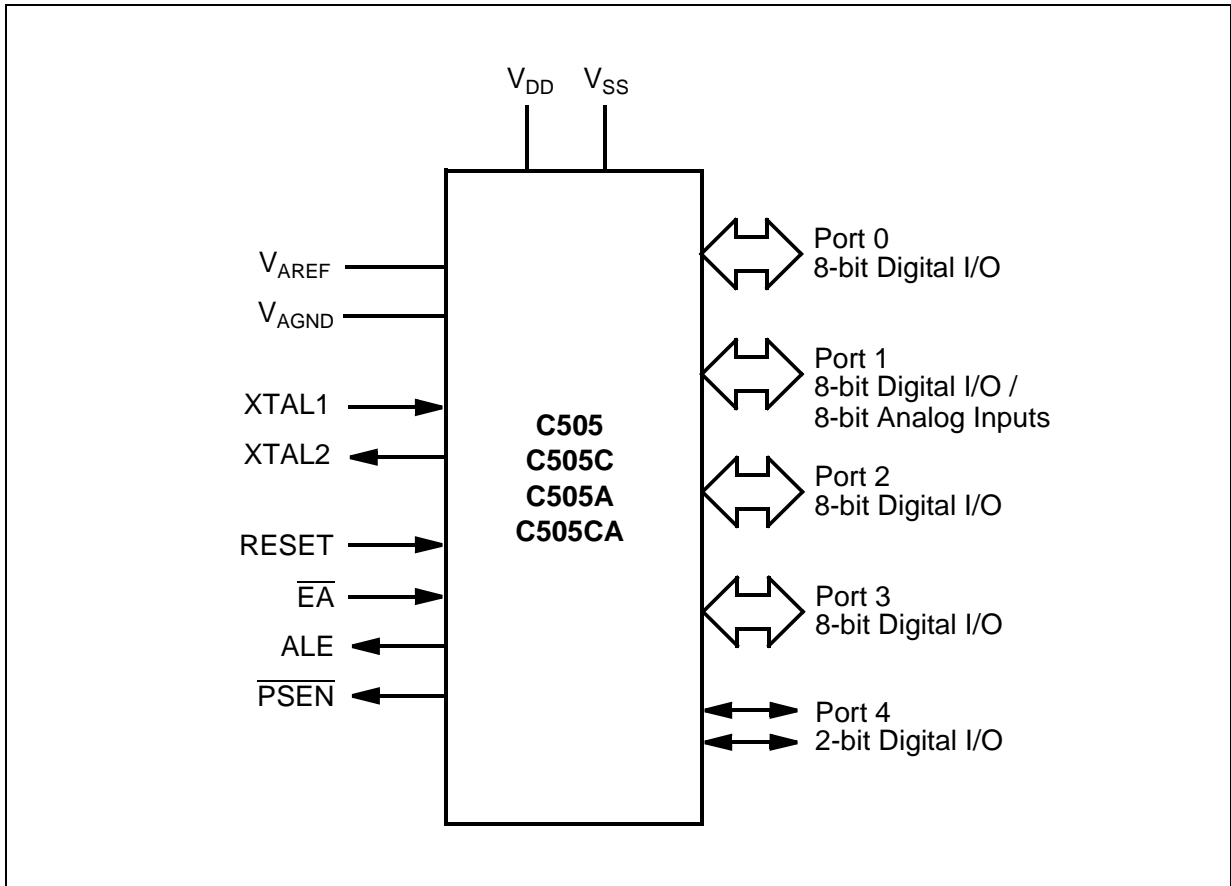

Figure 2
Logic Symbol

Note: The ordering codes for the Mask-ROM versions are defined for each product after verification of the respective ROM code.

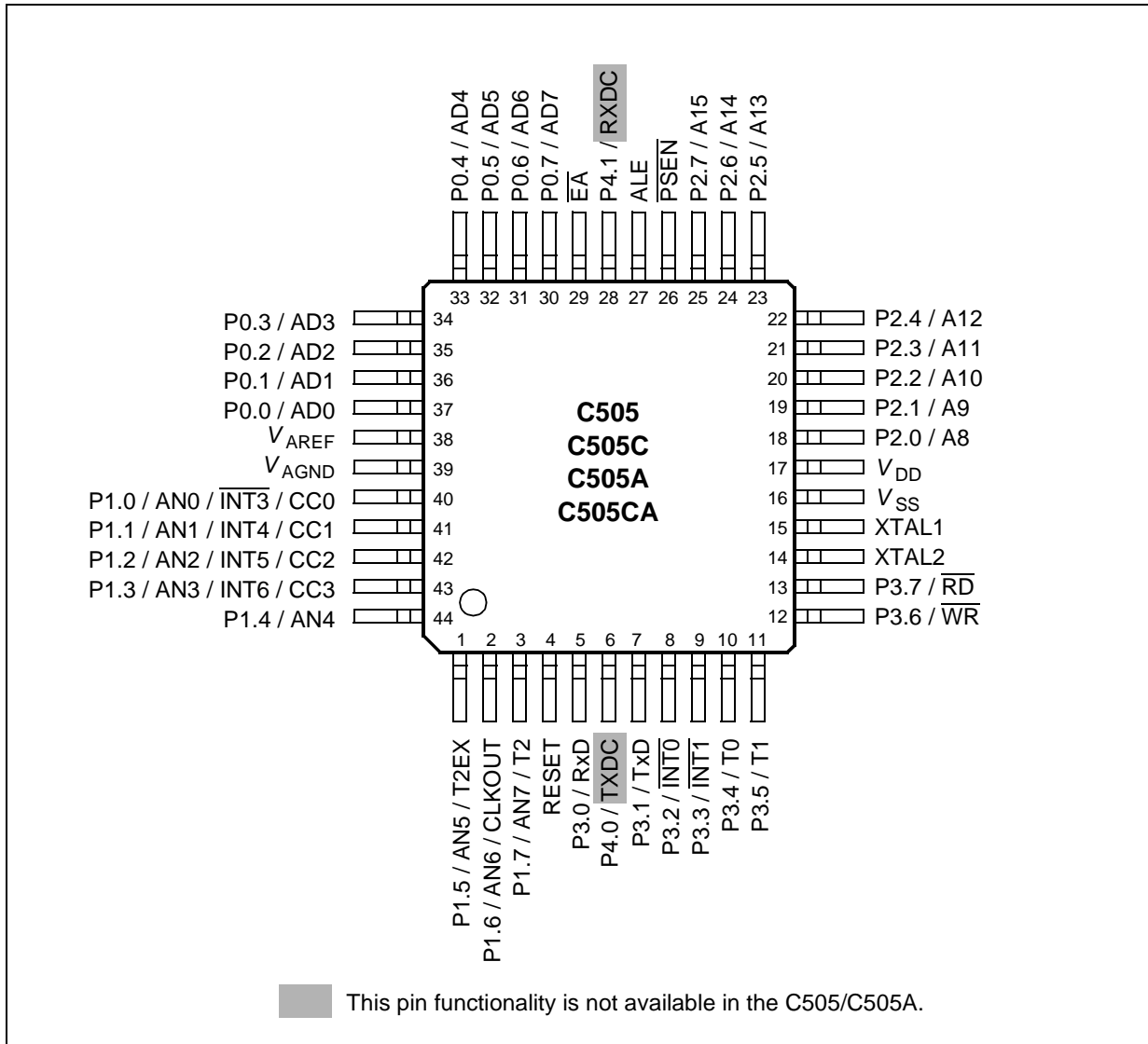

Figure 3
C505 Pin Configuration P-MQFP-44 Package (Top View)

Table 2
Pin Definitions and Functions

Symbol	Pin Number	I/O *)	Function
P1.0-P1.7	40-44,1-3	I/O	<p>Port 1 is an 8-bit quasi-bidirectional port with internal pull-up arrangement. Port 1 pins can be used for digital input/output or as analog inputs of the A/D converter. Port 1 pins that have 1's written to them are pulled high by internal pull-up transistors and in that state can be used as inputs. As inputs, port 1 pins being externally pulled low will source current (I_{IL}, in the DC characteristics) because of the internal pullup transistors. Port 1 pins are assigned to be used as analog inputs via the register P1ANA.</p> <p>As secondary digital functions, port 1 contains the interrupt, timer, clock, capture and compare pins. The output latch corresponding to a secondary function must be programmed to a one (1) for that function to operate (except for compare functions). The secondary functions are assigned to the pins of port 1 as follows:</p>
	40		P1.0 / AN0 / $\overline{INT3}$ / CC0 Analog input channel 0 interrupt 3 input / capture/compare channel 0 I/O
	41		P1.1 / AN1 / INT4 / CC1 Analog input channel 1/ interrupt 4 input / capture/compare channel 1 I/O
	42		P1.2 / AN2 / INT5 / CC2 Analog input channel 2 / interrupt 5 input / capture/compare channel 2 I/O
	43		P1.3 / AN3 / INT6 / CC3 Analog input channel 3 interrupt 6 input / capture/compare channel 3 I/O
	44		P1.4 / AN4 Analog input channel 4
	1		P1.5 / AN5 / T2EX Analog input channel 5 / Timer 2 external reload / trigger input
	2		P1.6 / AN6 / CLKOUT Analog input channel 6 / system clock output
	3		P1.7 / AN7 / T2 Analog input channel 7 / counter 2 input
			Port 1 is used for the low-order address byte during program verification of the C505 ROM versions (i.e. C505(C)(A)-2R/C505A-4R/C505CA-4R).

*) I = Input
O = Output

Table 2
Pin Definitions and Functions (cont'd)

Symbol	Pin Number	I/O)	Function
RESET	4	I	RESET A high level on this pin for two machine cycle while the oscillator is running resets the device. An internal diffused resistor to V_{SS} permits power-on reset using only an external capacitor to V_{DD} .
P3.0-P3.7	5, 7-13	I/O	Port 3 is an 8-bit quasi-bidirectional port with internal pull-up arrangement. Port 3 pins that have 1's written to them are pulled high by the internal pull-up transistors and in that state can be used as inputs. As inputs, port 3 pins being externally pulled low will source current (I_{IL} , in the DC characteristics) because of the internal pullup transistors. The output latch corresponding to a secondary function must be programmed to a one (1) for that function to operate (except for TxD and \overline{WR}). The secondary functions are assigned to the pins of port 3 as follows:
	5		P3.0 / RxD Receiver data input (asynch.) or data input/output (synch.) of serial interface
	7		P3.1 / TxD Transmitter data output (asynch.) or clock output (synch.) of serial interface
	8		P3.2 / $\overline{INT0}$ External interrupt 0 input / timer 0 gate control input
	9		P3.3 / $\overline{INT1}$ External interrupt 1 input / timer 1 gate control input
	10		P3.4 / T0 Timer 0 counter input
	11		P3.5 / T1 Timer 1 counter input
	12		P3.6 / \overline{WR} \overline{WR} control output; latches the data byte from port 0 into the external data memory
	13		P3.7 / \overline{RD} \overline{RD} control output; enables the external data memory

*) I = Input
 O = Output

Table 2
Pin Definitions and Functions (cont'd)

Symbol	Pin Number	I/O)	Function
P4.0 P4.1	6 28	I/O I/O	<p>Port 4 is a 2-bit quasi-bidirectional port with internal pull-up arrangement. Port 4 pins that have 1's written to them are pulled high by the internal pull-up transistors and in that state can be used as inputs. As inputs, port 4 pins being externally pulled low will source current (I_{IL}, in the DC characteristics) because of the internal pullup transistors. The output latch corresponding to the secondary function RXDC must be programmed to a one (1) for that function to operate. The secondary functions are assigned to the two pins of port 4 as follows (C505C and C505CA only) :</p> <p>P4.0 / TXDC Transmitter output of CAN controller P4.1 / RXDC Receiver input of CAN controller</p>
XTAL2	14	O	<p>XTAL2 Output of the inverting oscillator amplifier.</p>
XTAL1	15	I	<p>XTAL1 Input to the inverting oscillator amplifier and input to the internal clock generator circuits. To drive the device from an external clock source, XTAL1 should be driven, while XTAL2 is left unconnected. To operate above a frequency of 16 MHz, a duty cycle of the external clock signal of 50 % should be maintained. Minimum and maximum high and low times as well as rise/fall times specified in the AC characteristics must be observed.</p>

*) I = Input
O = Output

Table 2
Pin Definitions and Functions (cont'd)

Symbol	Pin Number	I/O)	Function
P2.0-P2.7	18-25	I/O	Port 2 is a an 8-bit quasi-bidirectional I/O port with internal pullup resistors. Port 2 pins that have 1's written to them are pulled high by the internal pullup resistors, and in that state can be used as inputs. As inputs, port 2 pins being externally pulled low will source current (I_{IL} , in the DC characteristics) because of the internal pullup resistors. Port 2 emits the high-order address byte during fetches from external program memory and during accesses to external data memory that use 16-bit addresses (MOVX @DPTR). In this application it uses strong internal pullup transistors when issuing 1s. During accesses to external data memory that use 8-bit addresses (MOVX @Ri), port 2 issues the contents of the P2 special function register and uses only the internal pullup resistors.
$\overline{\text{PSEN}}$	26	O	The Program Store Enable output is a control signal that enables the external program memory to the bus during external fetch operations. It is activated every three oscillator periods except during external data memory accesses. Remains high during internal program execution. This pin should not be driven during reset operation.
ALE	27	O	The Address Latch Enable output is used for latching the low-byte of the address into external memory during normal operation. It is activated every three oscillator periods except during an external data memory access. When instructions are executed from internal ROM or OTP ($\overline{\text{EA}}=1$) the ALE generation can be disabled by bit EALE in SFR SYSCON. ALE should not be driven during reset operation.

*) I = Input
 O = Output

Table 2
Pin Definitions and Functions (cont'd)

Symbol	Pin Number	I/O *)	Function
\overline{EA}	29	I	External Access Enable When held at high level, instructions are fetched from the internal program memory when the PC is less than 4000 _H (C505(C)(A)-2R) or 8000 _H (C505A-4R/C505CA-4R/C505A-4E/C505CA-4E). When held at low level, the C505 fetches all instructions from external program memory. For the C505 romless versions (i.e. C505-L, C505C-L, C505A-L and C505CA-L) this pin must be tied low. For the ROM protection version \overline{EA} pin is latched during reset.
P0.0-P0.7	37-30	I/O	Port 0 is an 8-bit open-drain bidirectional I/O port. Port 0 pins that have 1's written to them float, and in that state can be used as high-impedance inputs. Port 0 is also the multiplexed low-order address and data bus during accesses to external program or data memory. In this application it uses strong internal pullup transistors when issuing 1's. Port 0 also outputs the code bytes during program verification in the C505 ROM versions. External pullup resistors are required during program verification.
V_{AREF}	38	–	Reference voltage for the A/D converter.
V_{AGND}	39	–	Reference ground for the A/D converter.
V_{SS}	16	–	Ground (0V)
V_{DD}	17	–	Power Supply (+5V)

*) I = Input
 O = Output

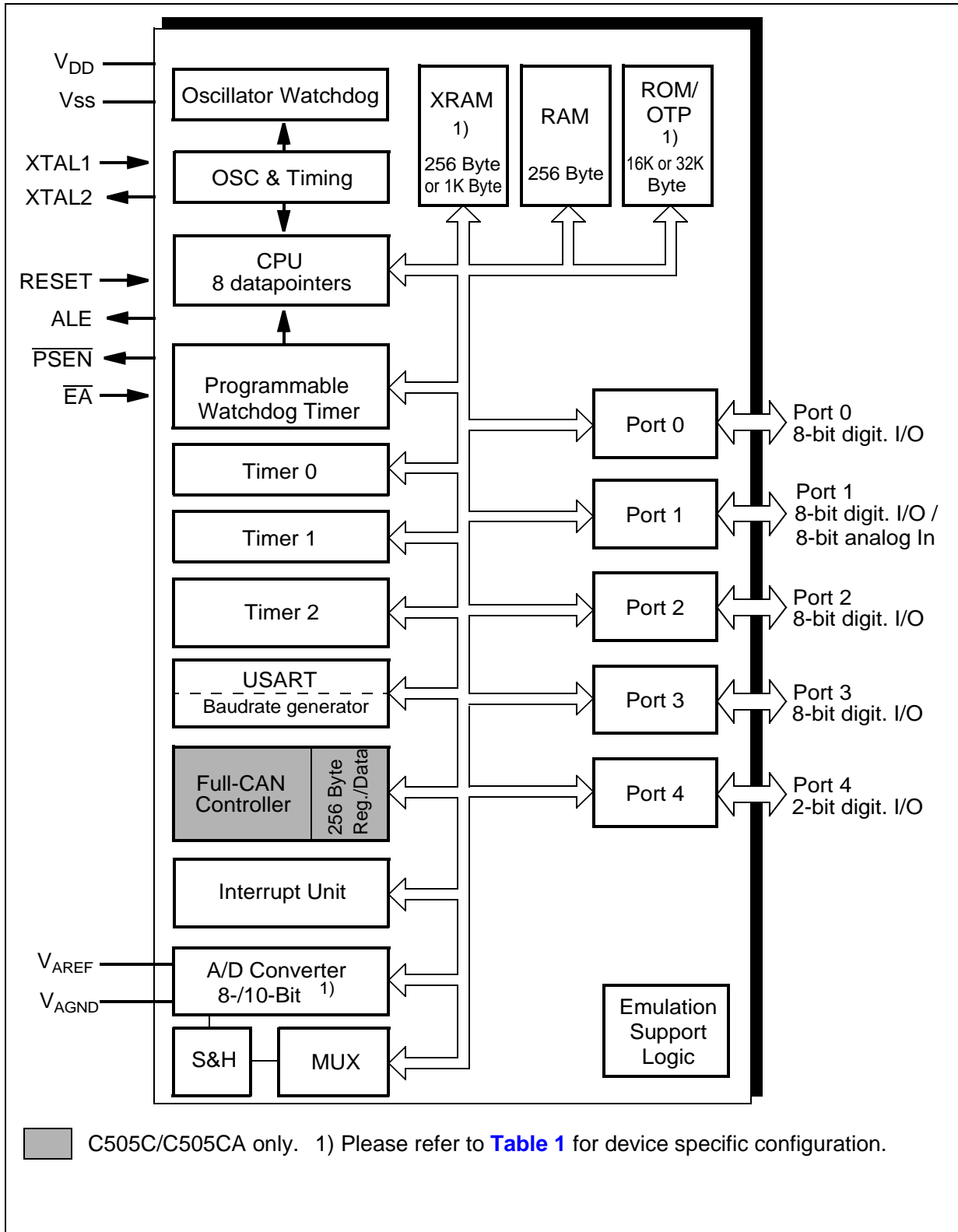

Figure 4
Block Diagram of the C505/C505C/C505A/C505CA

CPU

The C505 is efficient both as a controller and as an arithmetic processor. It has extensive facilities for binary and BCD arithmetic and excels in its bit-handling capabilities. Efficient use of program memory results from an instruction set consisting of 44 % one-byte, 41 % two-byte, and 15% three-byte instructions. With a 16 MHz crystal, 58% of the instructions are executed in 375 ns (20MHz: 300 ns).

Special Function Register PSW (Address D0_H)
Reset Value : 00_H

Bit No.	MSB							LSB	
	D7 _H	D6 _H	D5 _H	D4 _H	D3 _H	D2 _H	D1 _H	D0 _H	
D0 _H	CY	AC	F0	RS1	RS0	OV	F1	P	PSW

Bit	Function															
CY	Carry Flag Used by arithmetic instruction.															
AC	Auxiliary Carry Flag Used by instructions which execute BCD operations.															
F0	General Purpose Flag															
RS1 RS0	Register Bank Select Control Bits These bits are used to select one of the four register banks.															
	<table border="1"> <thead> <tr> <th>RS1</th> <th>RS0</th> <th>Function</th> </tr> </thead> <tbody> <tr> <td>0</td> <td>0</td> <td>Bank 0 selected, data address 00_H-07_H</td> </tr> <tr> <td>0</td> <td>1</td> <td>Bank 1 selected, data address 08_H-0F_H</td> </tr> <tr> <td>1</td> <td>0</td> <td>Bank 2 selected, data address 10_H-17_H</td> </tr> <tr> <td>1</td> <td>1</td> <td>Bank 3 selected, data address 18_H-1F_H</td> </tr> </tbody> </table>	RS1	RS0	Function	0	0	Bank 0 selected, data address 00 _H -07 _H	0	1	Bank 1 selected, data address 08 _H -0F _H	1	0	Bank 2 selected, data address 10 _H -17 _H	1	1	Bank 3 selected, data address 18 _H -1F _H
RS1	RS0	Function														
0	0	Bank 0 selected, data address 00 _H -07 _H														
0	1	Bank 1 selected, data address 08 _H -0F _H														
1	0	Bank 2 selected, data address 10 _H -17 _H														
1	1	Bank 3 selected, data address 18 _H -1F _H														
OV	Overflow Flag Used by arithmetic instruction.															
F1	General Purpose Flag															
P	Parity Flag Set/cleared by hardware after each instruction to indicate an odd/even number of "one" bits in the accumulator, i.e. even parity.															

Memory Organization

The C505 CPU manipulates operands in the following four address spaces:

- On-chip program memory : 16K byte ROM (C505(C)(A)-2R) or
32K byte ROM (C505A-4R/C505CA-4R) or
32K byte OTP (C505A-4E/C505CA-4E)
- Totally up to 64K byte internal/external program memory
- up to 64 Kbyte of external data memory
- 256 bytes of internal data memory
- Internal XRAM data memory : 256 byte (C505/C505C)
1K byte (C505A/C505CA)
- a 128 byte special function register area

Figure 5 illustrates the memory address spaces of the C505 versions.

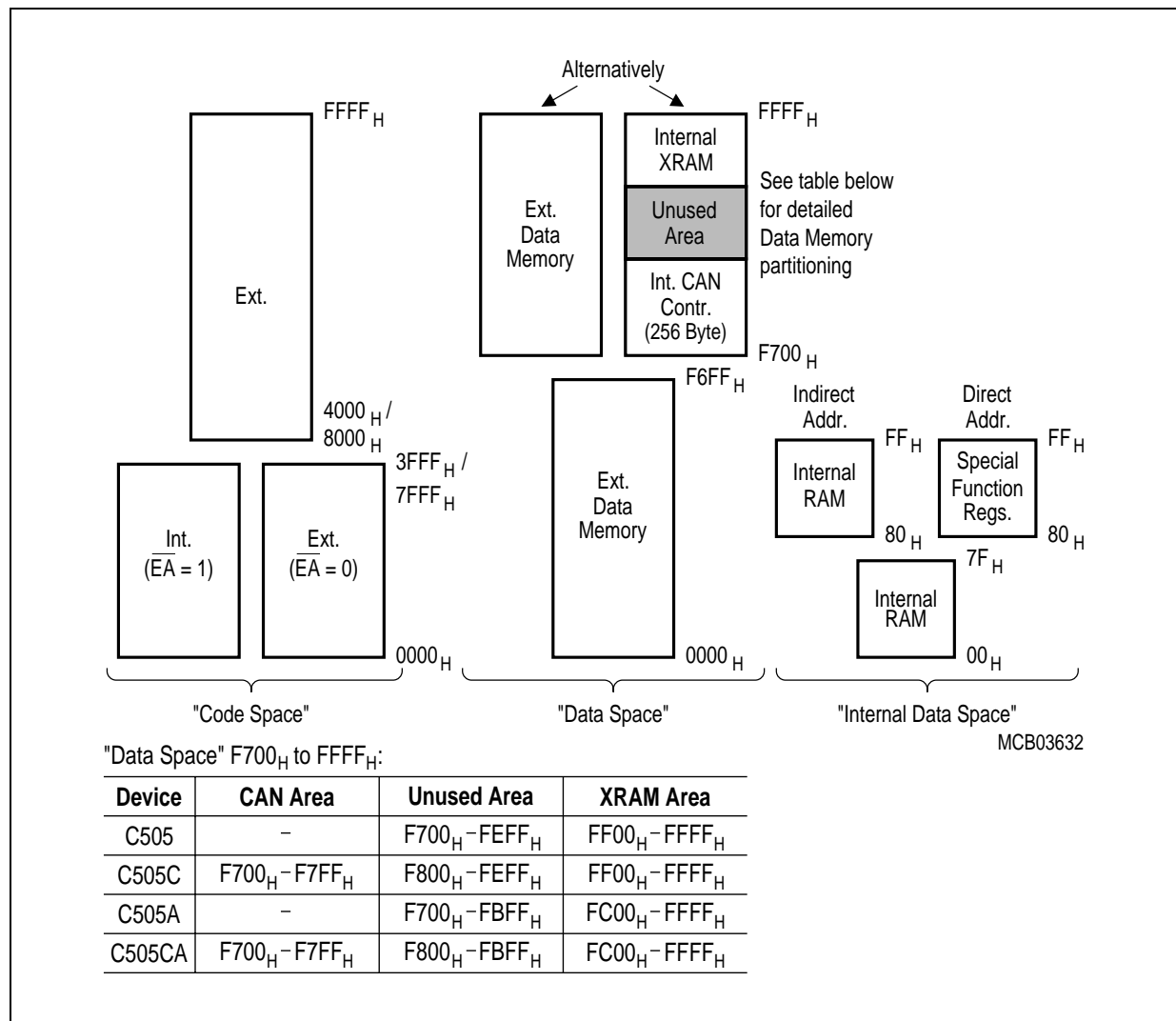

Figure 5
C505 Memory Map Memory Map

Reset and System Clock

The reset input is an active high input at pin RESET. Since the reset is synchronized internally, the RESET pin must be held high for at least two machine cycles (12 oscillator periods) while the oscillator is running. A pulldown resistor is internally connected to V_{SS} to allow a power-up reset with an external capacitor only. An automatic reset can be obtained when V_{DD} is applied by connecting the RESET pin to V_{DD} via a capacitor. **Figure 6** shows the possible reset circuitries.

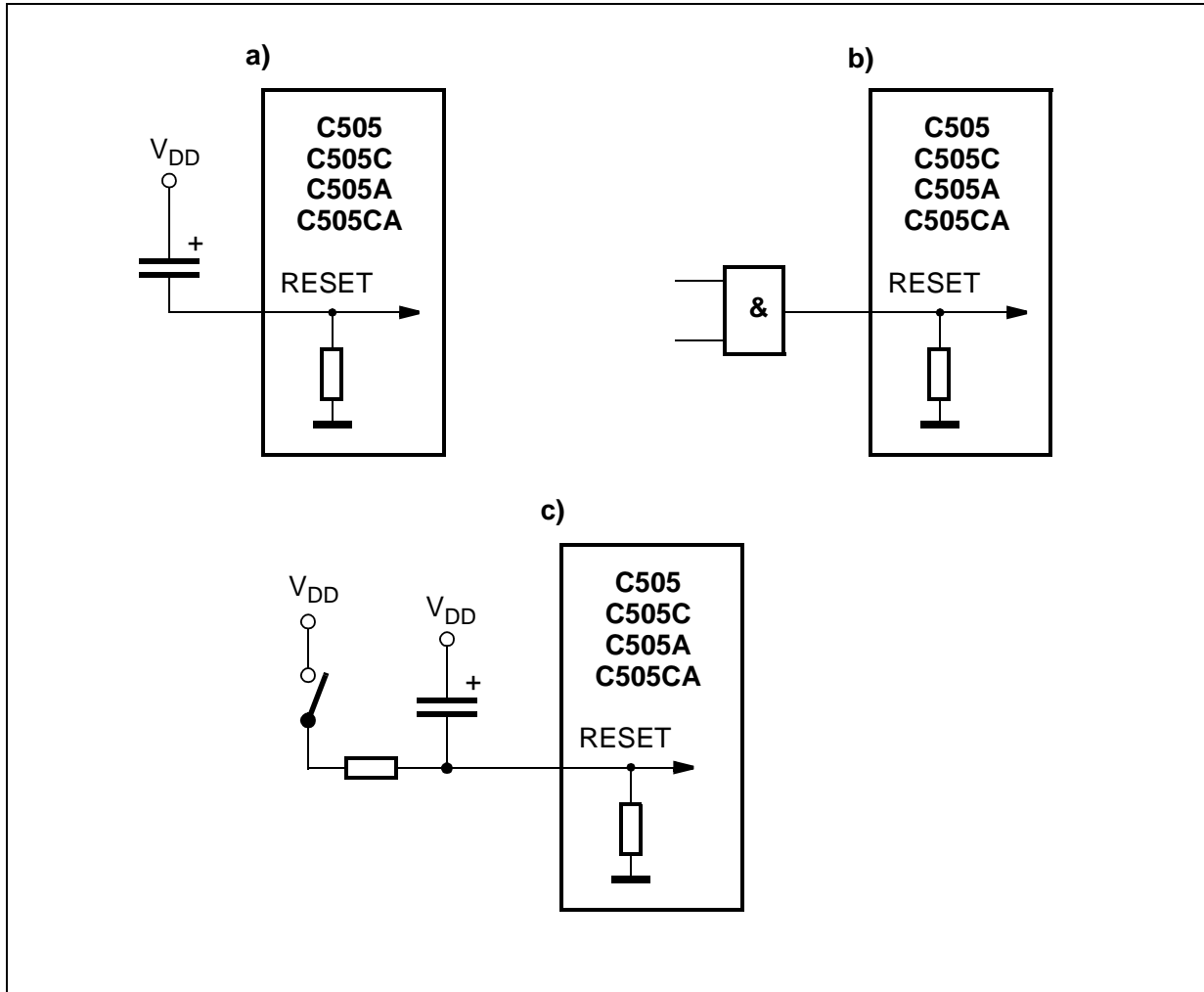

Figure 6
Reset Circuitries

Figure 7 shows the recommended oscillator circuits for crystal and external clock operation.

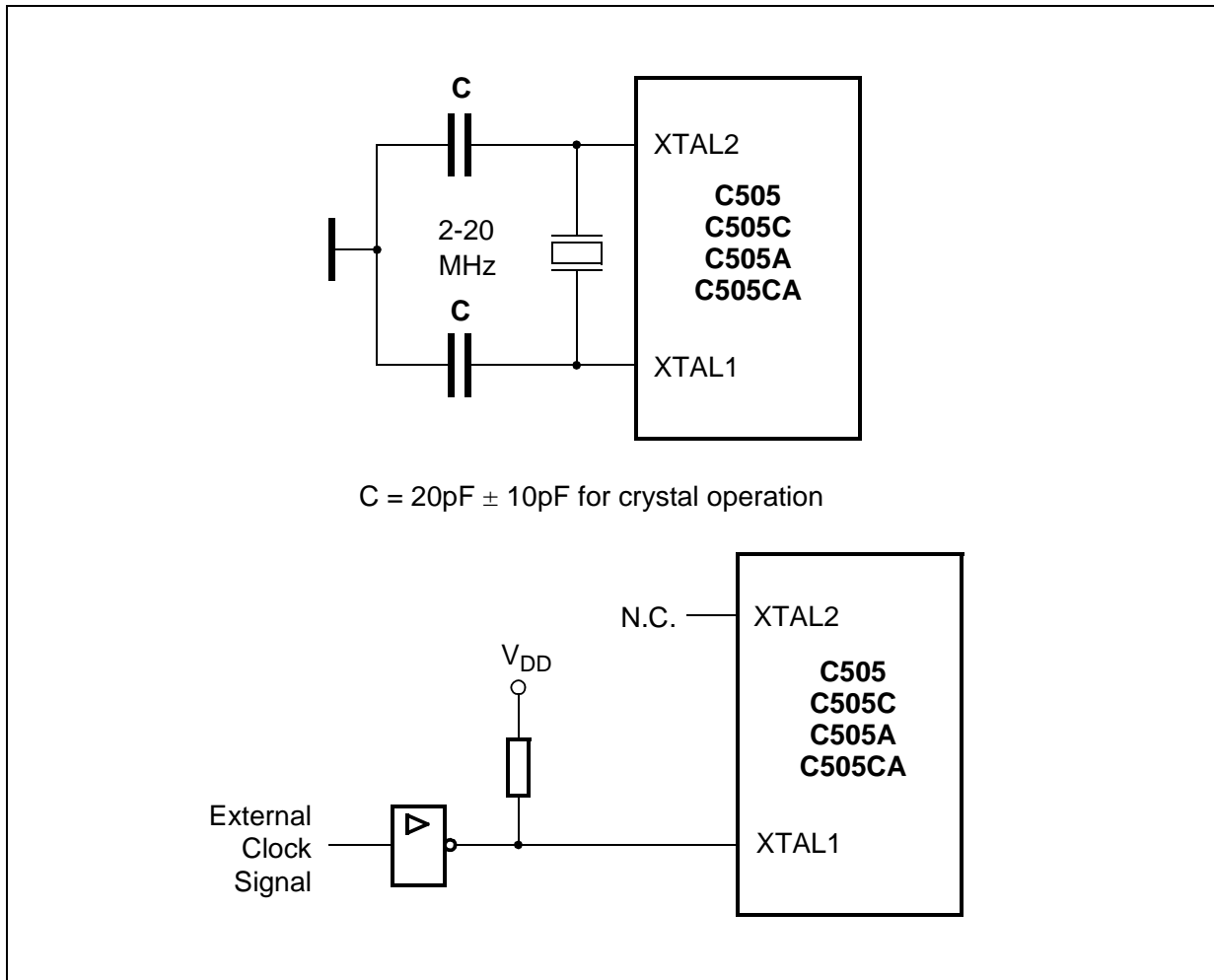

Figure 7
Recommended Oscillator Circuitries

Multiple Datapointers

As a functional enhancement to the standard 8051 architecture, the C505 contains eight 16-bit datapointers instead of only one datapointer. The instruction set uses just one of these datapointers at a time. The selection of the actual datapointer is done in the special function register DPSEL. **Figure 8** illustrates the datapointer addressing mechanism.

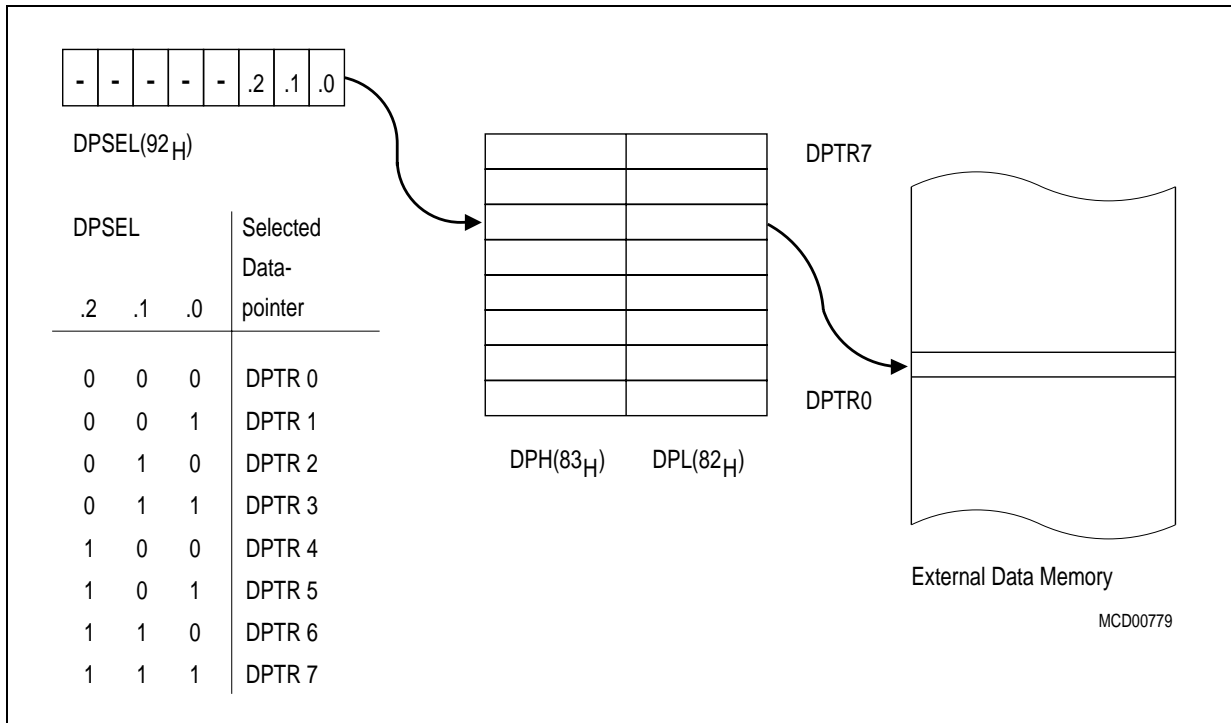

Figure 8
External Data Memory Addressing using Multiple Datapointers

Enhanced Hooks Emulation Concept

The Enhanced Hooks Emulation Concept of the C500 microcontroller family is a new, innovative way to control the execution of C500 MCUs and to gain extensive information on the internal operation of the controllers. Emulation of on-chip ROM based programs is possible, too.

Each production chip has built-in logic for the support of the Enhanced Hooks Emulation Concept. Therefore, no costly bond-out chips are necessary for emulation. This also ensure that emulation and production chips are identical.

The Enhanced Hooks Technology^{TM 1)}, which requires embedded logic in the C500 allows the C500 together with an EH-IC to function similar to a bond-out chip. This simplifies the design and reduces costs of an ICE-system. ICE-systems using an EH-IC and a compatible C500 are able to emulate all operating modes of the different versions of the C500 microcontrollers. This includes emulation of ROM, ROM with code rollover and ROMless modes of operation. It is also able to operate in single step mode and to read the SFRs after a break.

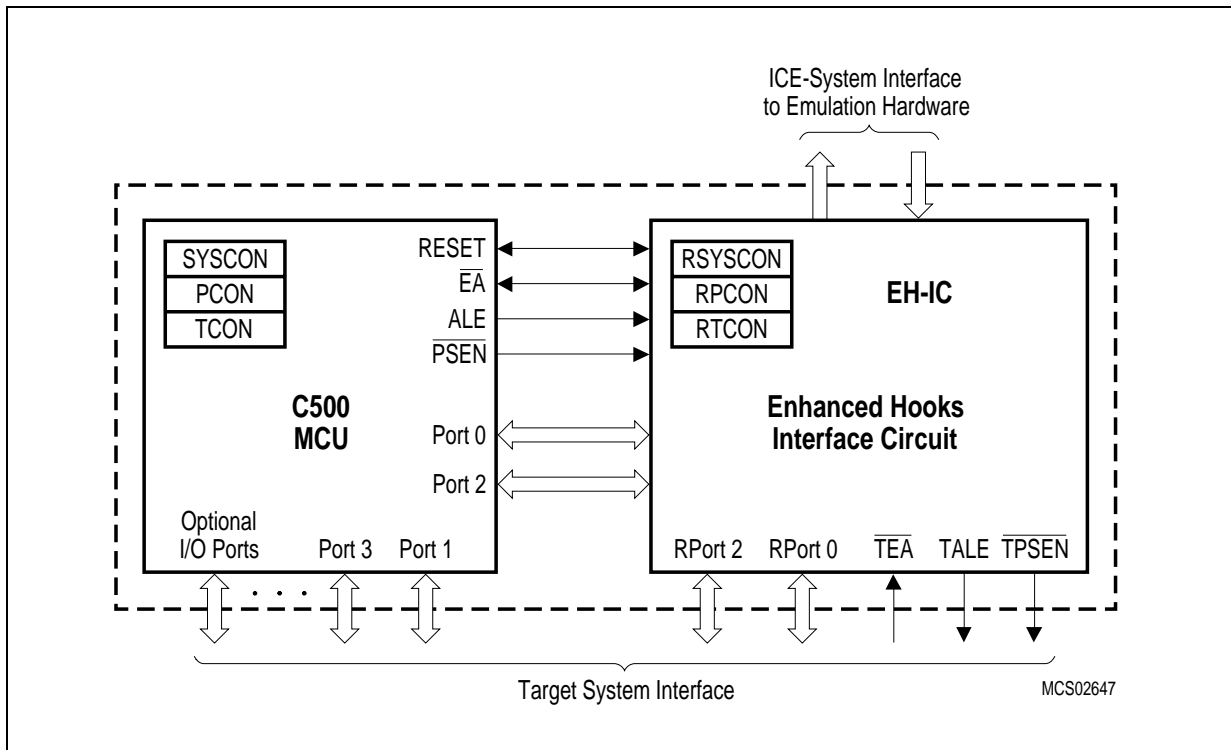

Figure 9
Basic C500 MCU Enhanced Hooks Concept Configuration

Port 0, port 2 and some of the control lines of the C500 based MCU are used by Enhanced Hooks Emulation Concept to control the operation of the device during emulation and to transfer informations about the programm execution and data transfer between the external emulation hardware (ICE-system) and the C500 MCU.

1) "Enhanced Hooks Technology" is a trademark and patent of Metalink Corporation licensed to Infineon Technologies.

Special Function Registers

The registers, except the program counter and the four general purpose register banks, reside in the special function register area. The special function register area consists of two portions : the standard special function register area and the mapped special function register area. Five special function register of the C505 (PCON1,P1ANA, VR0, VR1, VR2) are located in the mapped special function register area. For accessing the mapped special function register area, bit RMAP in special function register SYSCON must be set. All other special function registers are located in the standard special function register area which is accessed when RMAP is cleared ("0").

The registers and data locations of the CAN controller (CAN-SFRs) are located in the external data memory area at addresses F700_H to F7FF_H..

Special Function Register SYSCON (Address B1_H) (C505CA only)

Reset Value : XX100X01_B
Reset Value : XX100001_B

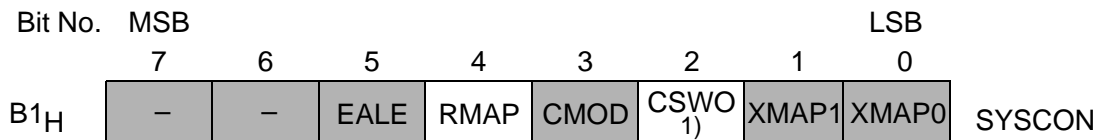

The functions of the shaded bits are not described here.
1) This bit is only available in the C505CA.

Bit	Function
RMAP	Special function register map bit RMAP = 0 : The access to the non-mapped (standard) special function register area is enabled. RMAP = 1 : The access to the mapped special function register area is enabled.
CSWO	CAN Controller switch-off bit CSWO = 0 : CAN Controller is enabled (default after reset). CSWO = 1 : CAN Controller is switched off.

As long as bit RMAP is set, mapped special function register area can be accessed. This bit is not cleared by hardware automatically. Thus, when non-mapped/mapped registers are to be accessed, the bit RMAP must be cleared/set respectively by software.

All SFRs with addresses where address bits 0-2 are 0 (e.g. 80_H, 88_H, 90_H, 98_H, ..., F8_H, FF_H) are bitaddressable.

The 52 special function registers (SFRs) in the standard and mapped SFR area include pointers and registers that provide an interface between the CPU and the other on-chip peripherals. The SFRs of the C505 are listed in [Table 3](#) and [Table 4](#). In [Table 3](#) they are organized in groups which refer to the functional blocks of the C505. The CAN-SFRs (applicable for the C505C and C505CA only) are also included in [Table 3](#). [Table 4](#) illustrates the contents of the SFRs in numeric order of their addresses. [Table 5](#) list the CAN-SFRs in numeric order of their addresses.

Table 3
Special Function Registers - Functional Blocks

Block	Symbol	Name	Address	Contents after Reset
CPU	ACC	Accumulator	E0H ¹⁾	00H
	B	B-Register	F0H ¹⁾	00H
	DPH	Data Pointer, High Byte	83H	00H
	DPL	Data Pointer, Low Byte	82H	00H
	DPSEL	Data Pointer Select Register	92H	XXXXX000B ³⁾
	PSW	Program Status Word Register	D0H ¹⁾	00H
	SP	Stack Pointer	81H	07H
	SYSCON ²⁾	System Control Register	B1H	XX100X01B ^{3) 6)} XX100001B ^{3) 7)}
	VR0 ⁴⁾	Version Register 0	FC _H	C5 _H
	VR1 ⁴⁾	Version Register 1	FD _H	05 _H
VR2 ⁴⁾	Version Register 2	FE _H	⁵⁾	
A/D- Converter	ADCON0 ²⁾	A/D Converter Control Register 0	D8H ¹⁾	00X00000B ³⁾
	ADCON1	A/D Converter Control Register 1	DC _H	01XXX000B ³⁾
	ADDAT	A/D Converter Data Reg. (C505/C505C)	D9 _H	00 _H
	ADST	A/D Converter Start Reg. (C505/C505C)	DA _H	XX _H ³⁾
	ADDATH	A/D Converter High Byte Data Register (C505A/C505CA)	D9 _H	00 _H
	ADDATL	A/D Converter Low Byte Data Register (C505A/C505CA)	DA _H	00XXXXXXB ³⁾
	P1ANA ^{2) 4)}	Port 1 Analog Input Selection Register	90 _H	FF _H
Interrupt System	IEN0 ²⁾	Interrupt Enable Register 0	A8H ¹⁾	00 _H
	IEN1 ²⁾	Interrupt Enable Register 1	B8H ¹⁾	00 _H
	IPO ²⁾	Interrupt Priority Register 0	A9 _H	00 _H
	IP1	Interrupt Priority Register 1	B9 _H	XX000000B ³⁾
	TCON ²⁾	Timer Control Register	88H ¹⁾	00 _H
	T2CON ²⁾	Timer 2 Control Register	C8H ¹⁾	00X00000B
	SCON ²⁾	Serial Channel Control Register	98H ¹⁾	00 _H
	IRCON	Interrupt Request Control Register	C0H ¹⁾	00 _H
XRAM	XPAGE	Page Address Register for Extended on-chip XRAM and CAN Controller	91 _H	00 _H
	SYSCON ²⁾	System Control Register	B1 _H	XX100X01B ^{3) 6)} XX100001B ^{3) 7)}

1) Bit-addressable special function registers

2) This special function register is listed repeatedly since some bits of it also belong to other functional blocks.

3) "X" means that the value is undefined and the location is reserved

4) This SFR is a mapped SFR. For accessing this SFR, bit RMAP in SFR SYSCON must be set.

5) The content of this SFR varies with the actual step of the C505 (eg. 01_H for the first step)

6) C505 / C505A/C505C only

7) C505CA only

Table 3
Special Function Registers - Functional Blocks (cont'd)

Block	Symbol	Name	Address	Contents after Reset
Ports	P0	Port 0	80H ¹⁾	FF _H
	P1	Port 1	90H ¹⁾	FF _H
	P1ANA ^{2) 4)}	Port 1 Analog Input Selection Register	90H ¹⁾	FF _H
	P2	Port 2	A0H ¹⁾	FF _H
	P3	Port 3	B0H ¹⁾	FF _H
	P4	Port 4	E8H ¹⁾	XXXXXX11 _B
Serial Channel	ADCON0 ²⁾	A/D Converter Control Register 0	D8H ¹⁾	00X00000 _B ³⁾
	PCON ²⁾	Power Control Register	87 _H	00 _H
	SBUF	Serial Channel Buffer Register	99 _H	XX _H ³⁾
	SCON	Serial Channel Control Register	98H ¹⁾	00 _H
	SRELL	Serial Channel Reload Register, low byte	AA _H	D9 _H
	SRELH	Serial Channel Reload Register, high byte	BA _H	XXXXXX11 _B ³⁾
Timer 0/ Timer 1	TCON	Timer 0/1 Control Register	88H ¹⁾	00 _H
	TH0	Timer 0, High Byte	8C _H	00 _H
	TH1	Timer 1, High Byte	8D _H	00 _H
	TL0	Timer 0, Low Byte	8A _H	00 _H
	TL1	Timer 1, Low Byte	8B _H	00 _H
	TMOD	Timer Mode Register	89 _H	00 _H
Compare/ Capture Unit / Timer 2	CCEN	Comp./Capture Enable Reg.	C1 _H	00 _H ³⁾
	CCH1	Comp./Capture Reg. 1, High Byte	C3 _H	00 _H
	CCH2	Comp./Capture Reg. 2, High Byte	C5 _H	00 _H
	CCH3	Comp./Capture Reg. 3, High Byte	C7 _H	00 _H
	CCL1	Comp./Capture Reg. 1, Low Byte	C2 _H	00 _H
	CCL2	Comp./Capture Reg. 2, Low Byte	C4 _H	00 _H
	CCL3	Comp./Capture Reg. 3, Low Byte	C6 _H	00 _H
	CRCH	Reload Register High Byte	CB _H	00 _H
	CRCL	Reload Register Low Byte	CA _H	00 _H
	TH2	Timer 2, High Byte	CD _H	00 _H
	TL2	Timer 2, Low Byte	CC _H	00 _H
	T2CON	Timer 2 Control Register	C8H ¹⁾	00X00000 _B ³⁾
	IEN0 ²⁾	Interrupt Enable Register 0	A8H ¹⁾	00 _H
	IEN1 ²⁾	Interrupt Enable Register 1	B8H ¹⁾	00 _H
	Watchdog	WDTREL	Watchdog Timer Reload Register	86 _H
IEN0 ²⁾		Interrupt Enable Register 0	A8H ¹⁾	00 _H
IEN1 ²⁾		Interrupt Enable Register 1	B8H ¹⁾	00 _H
IPO ²⁾		Interrupt Priority Register 0	A9 _H	00 _H
Pow. Save Modes	PCON ²⁾	Power Control Register	87 _H	00 _H
	PCON1 ⁴⁾	Power Control Register 1	88H ¹⁾	0XX0XXXX _B ³⁾

1) Bit-addressable special function registers

2) This special function register is listed repeatedly since some bits of it also belong to other functional blocks.

3) "X" means that the value is undefined and the location is reserved

4) SFR is located in the mapped SFR area. For accessing this SFR, bit RMAP in SFR SYSCON must be set.

Table 3
Special Function Registers - Functional Blocks (cont'd)

Block	Symbol	Name	Address	Contents after Reset	
CAN Controller	CR	Control Register	F700 _H	01 _H	
	SR	Status Register	F701 _H	XX _H ³⁾	
(C505C/ C505CA only)	IR	Interrupt Register	F702 _H	XX _H ³⁾	
	BTR0	Bit Timing Register Low	F704 _H	UU _H ³⁾	
	BTR1	Bit Timing Register High	F705 _H	0UUUUUU _B ³⁾	
	GMS0	Global Mask Short Register Low	F706 _H	UU _H ³⁾	
	GMS1	Global Mask Short Register High	F707 _H	UUU11111 _B ³⁾	
	UGML0	Upper Global Mask Long Register Low	F708 _H	UU _H ³⁾	
	UGML1	Upper Global Mask Long Register High	F709 _H	UU _H ³⁾	
	LGML0	Lower Global Mask Long Register Low	F70A _H	UU _H ³⁾	
	LGML1	Lower Global Mask Long Register High	F70B _H	UUUUU000 _B ³⁾	
	UMLM0	Upper Mask of Last Message Register Low	F70C _H	UU _H ³⁾	
	UMLM1	Upper Mask of Last Message Register High	F70D _H	UU _H ³⁾	
	LMLM0	Lower Mask of Last Message Register Low	F70E _H	UU _H ³⁾	
	LMLM1	Lower Mask of Last Message Register High	F70F _H	UUUUU000 _B ³⁾	
			Message Object Registers :		
		MCR0	Message Control Register Low	F7n0 _H ⁵⁾	UU _H ³⁾
		MCR1	Message Control Register High	F7n1 _H ⁵⁾	UU _H ³⁾
		UAR0	Upper Arbitration Register Low	F7n2 _H ⁵⁾	UU _H ³⁾
		UAR1	Upper Arbitration Register High	F7n3 _H ⁵⁾	UU _H ³⁾
		LAR0	Lower Arbitration Register Low	F7n4 _H ⁵⁾	UU _H ³⁾
		LAR1	Lower Arbitration Register High	F7n5 _H ⁵⁾	UUUUU000 _B ³⁾
		MCFG	Message Configuration Register	F7n6 _H ⁵⁾	UUUUUU00 _B ³⁾
		DB0	Message Data Byte 0	F7n7 _H ⁵⁾	XX _H ³⁾
		DB1	Message Data Byte 1	F7n8 _H ⁵⁾	XX _H ³⁾
		DB2	Message Data Byte 2	F7n9 _H ⁵⁾	XX _H ³⁾
		DB3	Message Data Byte 3	F7nA _H ⁵⁾	XX _H ³⁾
		DB4	Message Data Byte 4	F7nB _H ⁵⁾	XX _H ³⁾
		DB5	Message Data Byte 5	F7nC _H ⁵⁾	XX _H ³⁾
	DB6	Message Data Byte 6	F7nD _H ⁵⁾	XX _H ³⁾	
	DB7	Message Data Byte 7	F7nE _H ⁵⁾	XX _H ³⁾	

1) Bit-addressable special function registers

2) This special function register is listed repeatedly since some bits of it also belong to other functional blocks.

3) "X" means that the value is undefined and the location is reserved. "U" means that the value is unchanged by a reset operation. "U" values are undefined (as "X") after a power-on reset operation

4) SFR is located in the mapped SFR area. For accessing this SFR, bit RMAP in SFR SYSCON must be set.

5) The notation "n" (n= 1 to F) in the message object address definition defines the number of the related message object.

Table 4
Contents of the SFRs, SFRs in numeric order of their addresses

Addr	Register	Content after Reset ¹⁾	Bit 7	Bit 6	Bit 5	Bit 4	Bit 3	Bit 2	Bit 1	Bit 0
80 _H ²⁾	P0	FF _H	.7	.6	.5	.4	.3	.2	.1	.0
81 _H	SP	07 _H	.7	.6	.5	.4	.3	.2	.1	.0
82 _H	DPL	00 _H	.7	.6	.5	.4	.3	.2	.1	.0
83 _H	DPH	00 _H	.7	.6	.5	.4	.3	.2	.1	.0
86 _H	WDTREL	00 _H	WDT PSEL	.6	.5	.4	.3	.2	.1	.0
87 _H	PCON	00 _H	SMOD	PDS	IDLS	SD	GF1	GF0	PDE	IDLE
88 _H ²⁾	TCON	00 _H	TF1	TR1	TF0	TR0	IE1	IT1	IE0	IT0
88 _H ³⁾	PCON1	0XX0- XXXX _B	EWPD	–	–	WS	–	–	–	–
89 _H	TMOD	00 _H	GATE	C/ \bar{T}	M1	M0	GATE	C/ \bar{T}	M1	M0
8A _H	TL0	00 _H	.7	.6	.5	.4	.3	.2	.1	.0
8B _H	TL1	00 _H	.7	.6	.5	.4	.3	.2	.1	.0
8C _H	TH0	00 _H	.7	.6	.5	.4	.3	.2	.1	.0
8D _H	TH1	00 _H	.7	.6	.5	.4	.3	.2	.1	.0
90 _H ²⁾	P1	FF _H	T2	CLK- OUT	T2EX	.4	INT6	INT5	INT4	$\bar{INT3}$
90 _H ³⁾	P1ANA	FF _H	EAN7	EAN6	EAN5	EAN4	EAN3	EAN2	EAN1	EAN0
91 _H	XPAGE	00 _H	.7	.6	.5	.4	.3	.2	.1	.0
92 _H	DPSEL	XXXX- X000 _B	–	–	–	–	–	.2	.1	.0
98 _H ²⁾	SCON	00 _H	SM0	SM1	SM2	REN	TB8	RB8	TI	RI
99 _H	SBUF	XX _H	.7	.6	.5	.4	.3	.2	.1	.0
A0 _H ²⁾	P2	FF _H	.7	.6	.5	.4	.3	.2	.1	.0
A8 _H ²⁾	IEN0	00 _H	EA	WDT	ET2	ES	ET1	EX1	ET0	EX0
A9 _H	IP0	00 _H	OWDS	WDTS	.5	.4	.3	.2	.1	.0
AA _H	SRELL	D9 _H	.7	.6	.5	.4	.3	.2	.1	.0

1) X means that the value is undefined and the location is reserved

2) Bit-addressable special function registers

3) SFR is located in the mapped SFR area. For accessing this SFR, bit RMAP in SFR SYSCON must be set.

Table 4
Contents of the SFRs, SFRs in numeric order of their addresses (cont'd)

Addr	Register	Content after Reset ¹⁾	Bit 7	Bit 6	Bit 5	Bit 4	Bit 3	Bit 2	Bit 1	Bit 0
B0 _H ²⁾	P3	FF _H	R \bar{D}	WR	T1	T0	$\bar{INT}1$	$\bar{INT}0$	TxD	RxD
B1 _H	SYSCON ³⁾	XX10-0X01 _B	–	–	EALE	RMAP	CMOD	–	XMAP1	XMAP0
B1 _H	SYSCON ⁴⁾	XX10-0001 _B	–	–	EALE	RMAP	CMOD	CSWO	XMAP1	XMAP0
B8 _H ²⁾	IEN1	00 _H	EXEN2	SWDT	EX6	EX5	EX4	EX3	ECAN	EADC
B9 _H	IP1	XX00-0000 _B	–	–	.5	.4	.3	.2	.1	.0
BA _H	SRELH	XXXX-XX11 _B	–	–	–	–	–	–	.1	.0
C0 _H ²⁾	IRCON	00 _H	EXF2	TF2	IEX6	IEX5	IEX4	IEX3	SWI	IADC
C1 _H	CCEN	00 _H	COCA H3	COCAL 3	COCA H2	COCAL 2	COCA H1	COCAL 1	COCA H0	COCAL 0
C2 _H	CCL1	00 _H	.7	.6	.5	.4	.3	.2	.1	.0
C3 _H	CCH1	00 _H	.7	.6	.5	.4	.3	.2	.1	.0
C4 _H	CCL2	00 _H	.7	.6	.5	.4	.3	.2	.1	.0
C5 _H	CCH2	00 _H	.7	.6	.5	.4	.3	.2	.1	.0
C6 _H	CCL3	00 _H	.7	.6	.5	.4	.3	.2	.1	.0
C7 _H	CCH3	00 _H	.7	.6	.5	.4	.3	.2	.1	.0
C8 _H ²⁾	T2CON	00X0-0000 _B	T2PS	I3FR	–	T2R1	T2R0	T2CM	T2I1	T2I0
CA _H	CRCL	00 _H	.7	.6	.5	.4	.3	.2	.1	.0
CB _H	CRCH	00 _H	.7	.6	.5	.4	.3	.2	.1	.0
CC _H	TL2	00 _H	.7	.6	.5	.4	.3	.2	.1	.0
CD _H	TH2	00 _H	.7	.6	.5	.4	.3	.2	.1	.0
D0 _H ²⁾	PSW	00 _H	CY	AC	F0	RS1	RS0	OV	F1	P
D8 _H ²⁾	ADCON0	00X0-0000 _B	BD	CLK	–	BSY	ADM	MX2	MX1	MX0

1) X means that the value is undefined and the location is reserved

2) Bit-addressable special function registers

3) C505 /C505C/C505A only

4) C505CA only

Table 4
Contents of the SFRs, SFRs in numeric order of their addresses (cont'd)

Addr	Register	Content after Reset ¹⁾	Bit 7	Bit 6	Bit 5	Bit 4	Bit 3	Bit 2	Bit 1	Bit 0
D9 _H	ADDAT ⁶⁾	00 _H	.7	.6	.5	.4	.3	.2	.1	.0
D9 _H	ADDATH ⁷⁾	00 _H	.9	.8	.7	.6	.5	.4	.3	.2
DA _H	ADST ⁶⁾	XXXX-XXXX _B	–	–	–	–	–	–	–	–
DA _H	ADDATL ⁷⁾	00XX-XXXX _B	.1	.0	–	–	–	–	–	–
DC _H	ADCON1	01XX-X000 _B	ADCL1	ADCL0	–	–	–	MX2	MX1	MX0
E0 _H ²⁾	ACC	00 _H	.7	.6	.5	.4	.3	.2	.1	.0
E8 _H ²⁾	P4	XXXX-XX11 _B	–	–	–	–	–	–	RXDC	TXDC
F0 _H ²⁾	B	00 _H	.7	.6	.5	.4	.3	.2	.1	.0
FC _H ^{3,4)}	VR0	C5 _H	1	1	0	0	0	1	0	1
FD _H ^{3,4)}	VR1	05 _H	0	0	0	0	0	1	0	1
FE _H ^{3,4)}	VR2 ⁵⁾	01 _H ⁸⁾ 12 _H ⁹⁾ 33 _H ¹⁰⁾	.7	.6	.5	.4	.3	.2	.1	.0

1) X means that the value is undefined and the location is reserved

2) Bit-addressable special function registers

3) SFR is located in the mapped SFR area. For accessing this SFR, bit RMAP in SFR SYSCON must be set.

4) These are read-only registers

5) The content of this SFR varies with the actual of the step C505 (eg. 01_H or 11_H or 21_H for the first step)

6) C505 / C505C only

7) C505A / C505CA only

8) C505 / C505C AB step only

9) C505A-4E / C505CA-4E BA step only (11_H for the AA step)

10) C505A-4R / C505CA-4R BB step only (32_H for the BA step)

Table 5
Contents of the CAN Registers in numeric order of their addresses
(C505C/C505CA only)

Addr. n=1-F _H 1)	Register	Content after Reset ²⁾	Bit 7	Bit 6	Bit 5	Bit 4	Bit 3	Bit 2	Bit 1	Bit 0
F700 _H	CR	01 _H	TEST	CCE	0	0	EIE	SIE	IE	INIT
F701 _H	SR	XX _H	BOFF	EWRN	–	RXOK	TXOK	LEC2	LEC1	LEC0
F702 _H	IR	XX _H	INTID							
F704 _H	BTR0	UU _H	SJW		BRP					
F705 _H	BTR1	0UUU. UUUU _B	0	TSEG2			TSEG1			
F706 _H	GMS0	UU _H	ID28-21							
F707 _H	GMS1	UUU1. 1111 _B	ID20-18			1	1	1	1	1
F708 _H	UGML0	UU _H	ID28-21							
F709 _H	UGML1	UU _H	ID20-13							
F70A _H	LGML0	UU _H	ID12-5							
F70B _H	LGML1	UUUU. U000 _B	ID4-0				0	0	0	
F70C _H	UMLM0	UU _H	ID28-21							
F70D _H	UMLM1	UU _H	ID20-18			ID17-13				
F70E _H	LMLM0	UU _H	ID12-5							
F70F _H	LMLM1	UUUU. U000 _B	ID4-0				0	0	0	
F7n0 _H	MCR0	UU _H	MSGVAL		TXIE		RXIE		INTPND	
F7n1 _H	MCR1	UU _H	RMTPND		TXRQ		MSGLST CPUUPD		NEWDAT	
F7n2 _H	UAR0	UU _H	ID28-21							
F7n3 _H	UAR1	UU _H	ID20-18			ID17-13				
F7n4 _H	LAR0	UU _H	ID12-5							
F7n5 _H	LAR1	UUUU. U000 _B	ID4-0				0	0	0	

- 1) The notation “n” (n= 1 to F) in the address definition defines the number of the related message object.
2) “X” means that the value is undefined and the location is reserved. “U” means that the value is unchanged by a reset operation. “U” values are undefined (as “X”) after a power-on reset operation

Table 5
Contents of the CAN Registers in numeric order of their addresses (cont'd)
(C505C/C505CA only)

Addr. n=1-F _H 1)	Register	Content after Reset ²⁾	Bit 7	Bit 6	Bit 5	Bit 4	Bit 3	Bit 2	Bit 1	Bit 0
F7n6 _H	MCFG	UUUU. UU00 _B	DLC				DIR	XTD	0	0
F7n7 _H	DB0	XX _H	.7	.6	.5	.4	.3	.2	.1	.0
F7n8 _H	DB1	XX _H	.7	.6	.5	.4	.3	.2	.1	.0
F7n9 _H	DB2	XX _H	.7	.6	.5	.4	.3	.2	.1	.0
F7nA _H	DB3	XX _H	.7	.6	.5	.4	.3	.2	.1	.0
F7nB _H	DB4	XX _H	.7	.6	.5	.4	.3	.2	.1	.0
F7nC _H	DB5	XX _H	.7	.6	.5	.4	.3	.2	.1	.0
F7nD _H	DB6	XX _H	.7	.6	.5	.4	.3	.2	.1	.0
F7nE _H	DB7	XX _H	.7	.6	.5	.4	.3	.2	.1	.0

1) The notation “n” (n= 1 to F) in the address definition defines the number of the related message object.

2) “X” means that the value is undefined and the location is reserved. “U” means that the value is unchanged by a reset operation. “U” values are undefined (as “X”) after a power-on reset operation

I/O Ports

The C505 has four 8-bit I/O ports and one 2-bit I/O port. Port 0 is an open-drain bidirectional I/O port, while ports 1 to 4 are quasi-bidirectional I/O ports with internal pullup resistors. That means, when configured as inputs, ports 1 to 4 will be pulled high and will source current when externally pulled low. Port 0 will float when configured as input.

The output drivers of port 0 and 2 and the input buffers of port 0 are also used for accessing external memory. In this application, port 0 outputs the low byte of the external memory address, time multiplexed with the byte being written or read. Port 2 outputs the high byte of the external memory address when the address is 16 bits wide. Otherwise, the port 2 pins continue emitting the P2 SFR contents. In this function, port 0 is not an open-drain port, but uses a strong internal pullup FET .

Port 4 is 2-bit I/O port with CAN controller specific alternate functions. The eight analog input lines are realized as mixed digital/analog inputs. The 8 analog inputs, AN0-AN7, are located at the port 1 pins P1.0 to P1.7. After reset, all analog inputs are disabled and the related pins of port 1 are configured as digital inputs. The analog function of a specific port 1 pin is enabled by bits in the SFR P1ANA. Writing a 0 to a bit position of P1ANA assigns the corresponding pin to operate as analog input.

Note : P1ANA is a mapped SFR and can be only accessed if bit RMAP in SFR SYSCON is set.

Timer / Counter 0 and 1

Timer/Counter 0 and 1 can be used in four operating modes as listed in **Table 6** :

Table 6
Timer/Counter 0 and 1 Operating Modes

Mode	Description	TMOD		Input Clock	
		M1	M0	internal	external (max)
0	8-bit timer/counter with a divide-by-32 prescaler	0	0	$f_{osc}/6 \times 32$	$f_{osc}/12 \times 32$
1	16-bit timer/counter	0	1	$f_{osc}/6$	$f_{osc}/12$
2	8-bit timer/counter with 8-bit autoreload	1	0		
3	Timer/counter 0 used as one 8-bit timer/counter and one 8-bit timer Timer 1 stops	1	1		

In the “timer” function ($C/\bar{T} = '0'$) the register is incremented every machine cycle. Therefore the count rate is $f_{osc}/6$.

In the “counter” function the register is incremented in response to a 1-to-0 transition at its corresponding external input pin (P3.4/T0, P3.5/T1). Since it takes two machine cycles to detect a falling edge the max. count rate is $f_{osc}/12$. External inputs $\overline{INT0}$ and $\overline{INT1}$ (P3.2, P3.3) can be programmed to function as a gate to facilitate pulse width measurements. **Figure 10** illustrates the input clock logic.

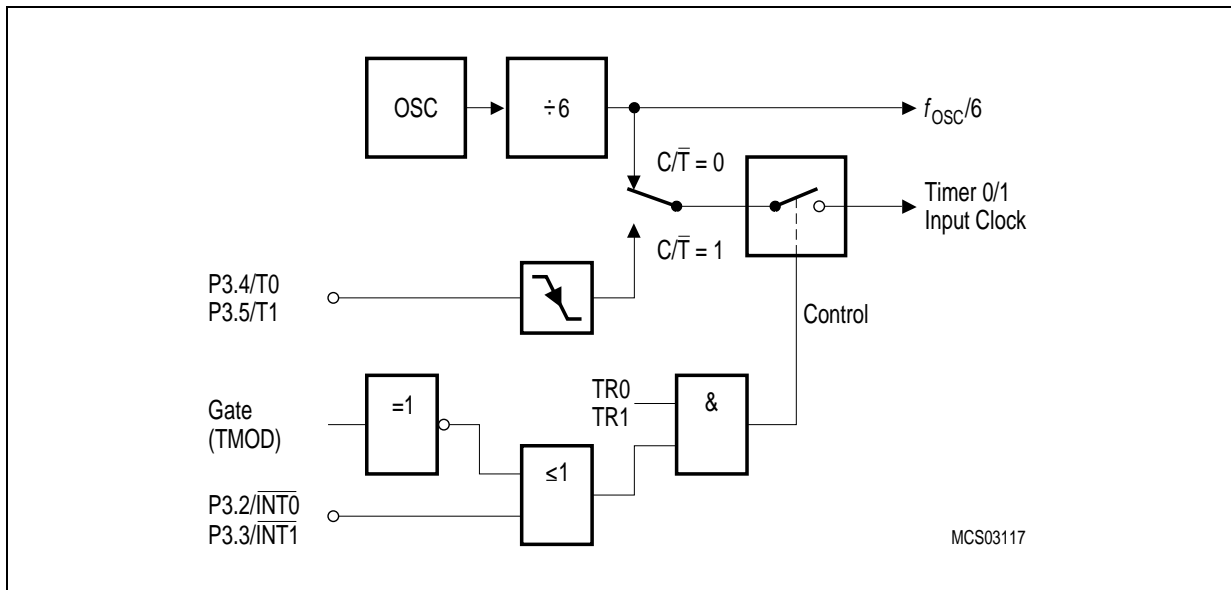

Figure 10
Timer/Counter 0 and 1 Input Clock Logic

Timer/Counter 2 with Compare/Capture/Reload

The timer 2 of the C505 provides additional compare/capture/reload features, which allow the selection of the following operating modes:

- Compare : up to 4 PWM signals with 16-bit/300 ns resolution (@ 20 MHz clock)
- Capture : up to 4 high speed capture inputs with 300 ns resolution
- Reload : modulation of timer 2 cycle time

The block diagram in **Figure 11** shows the general configuration of timer 2 with the additional compare/capture/reload registers. The I/O pins which can be used for timer 2 control are located as multifunctional port functions at port 1.

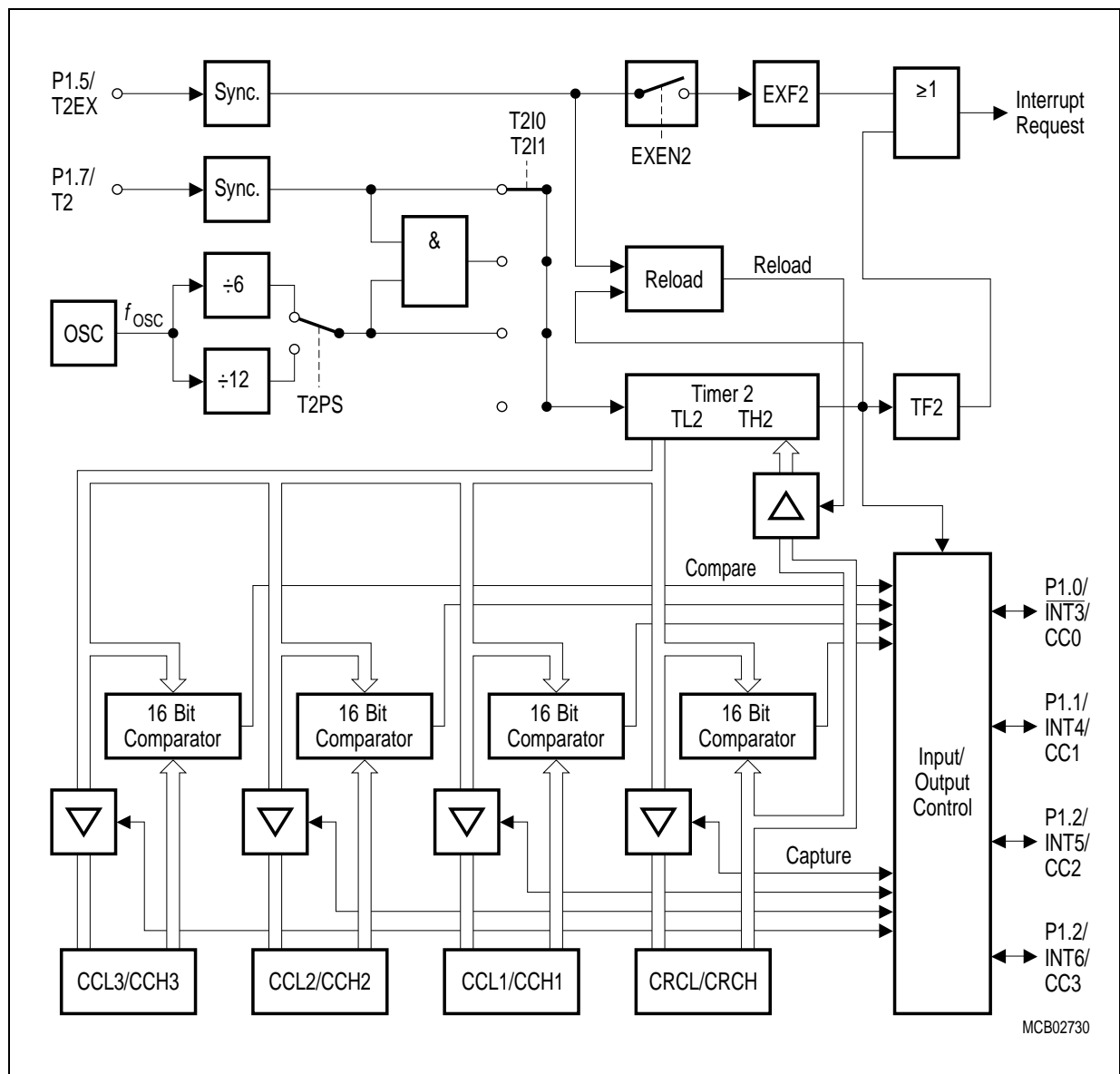

Figure 11
Timer 2 Block Diagram

Timer 2 Operating Modes

The timer 2, which is a 16-bit-wide register, can operate as timer, event counter, or gated timer. A roll-over of the count value in TL2/TH2 from all 1's to all 0's sets the timer overflow flag TF2 in SFR IRCON, which can generate an interrupt. The bits in register T2CON are used to control the timer 2 operation.

Timer Mode : In timer function, the count rate is derived from the oscillator frequency. A prescaler offers the possibility of selecting a count rate of 1/6 or 1/12 of the oscillator frequency.

Gated Timer Mode : In gated timer function, the external input pin T2 (P1.7) functions as a gate to the input of timer 2. If T2 is high, the internal clock input is gated to the timer. T2 = 0 stops the counting procedure. This facilitates pulse width measurements. The external gate signal is sampled once every machine cycle.

Event Counter Mode : In the event counter function, the timer 2 is incremented in response to a 1-to-0 transition at its corresponding external input pin T2 (P1.7). In this function, the external input is sampled every machine cycle. Since it takes two machine cycles (12 oscillator periods) to recognize a 1-to-0 transition, the maximum count rate is 1/6 of the oscillator frequency. There are no restrictions on the duty cycle of the external input signal, but to ensure that a given level is sampled at least once before it changes, it must be held for at least one full machine cycle.

Reload of Timer 2 : Two reload modes are selectable:

In mode 0, when timer 2 rolls over from all 1's to all 0's, it not only sets TF2 but also causes the timer 2 registers to be loaded with the 16-bit value in the CRC register, which is preset by software.

In mode 1, a 16-bit reload from the CRC register is caused by a negative transition at the corresponding input pin P1.5/T2EX. This transition will also set flag EXF2 if bit EXEN2 in SFR IEN1 has been set.

Timer 2 Compare Modes

The compare function of a timer/register combination operates as follows : the 16-bit value stored in a compare or compare/capture register is compared with the contents of the timer register; if the count value in the timer register matches the stored value, an appropriate output signal is generated at a corresponding port pin and an interrupt can be generated.

Compare Mode 0

In compare mode 0, upon matching the timer and compare register contents, the output signal changes from low to high. It goes back to a low level on timer overflow. As long as compare mode 0 is enabled, the appropriate output pin is controlled by the timer circuit only and writing to the port will have no effect. **Figure 12** shows a functional diagram of a port circuit when used in compare mode 0. The port latch is directly controlled by the timer overflow and compare match signals. The input line from the internal bus and the write-to-latch line of the port latch are disconnected when compare mode 0 is enabled.

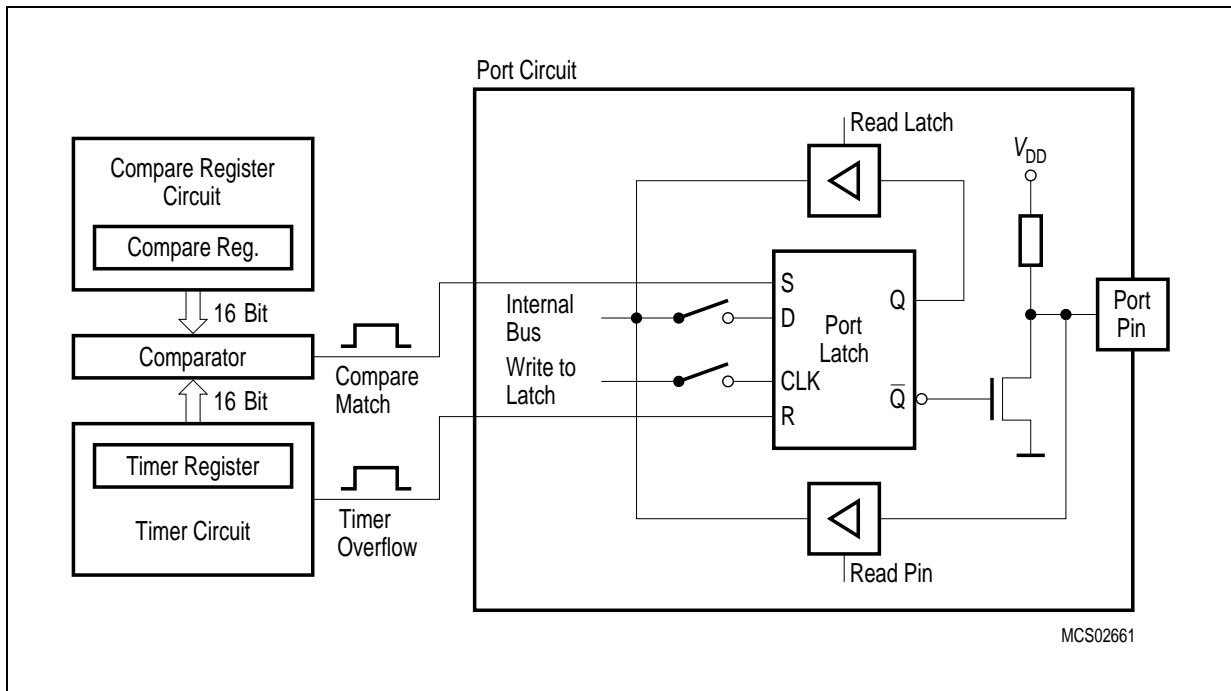

Figure 12
Port Latch in Compare Mode 0

Compare Mode 1

If compare mode 1 is enabled and the software writes to the appropriate output latch at the port, the new value will not appear at the output pin until the next compare match occurs. Thus, it can be chosen whether the output signal has to make a new transition (1-to-0 or 0-to-1, depending on the actual pin-level) or should keep its old value at the time when the timer value matches the stored compare value.

In compare mode 1 (see **Figure 13**) the port circuit consists of two separate latches. One latch (which acts as a "shadow latch") can be written under software control, but its value will only be transferred to the port latch (and thus to the port pin) when a compare match occurs.

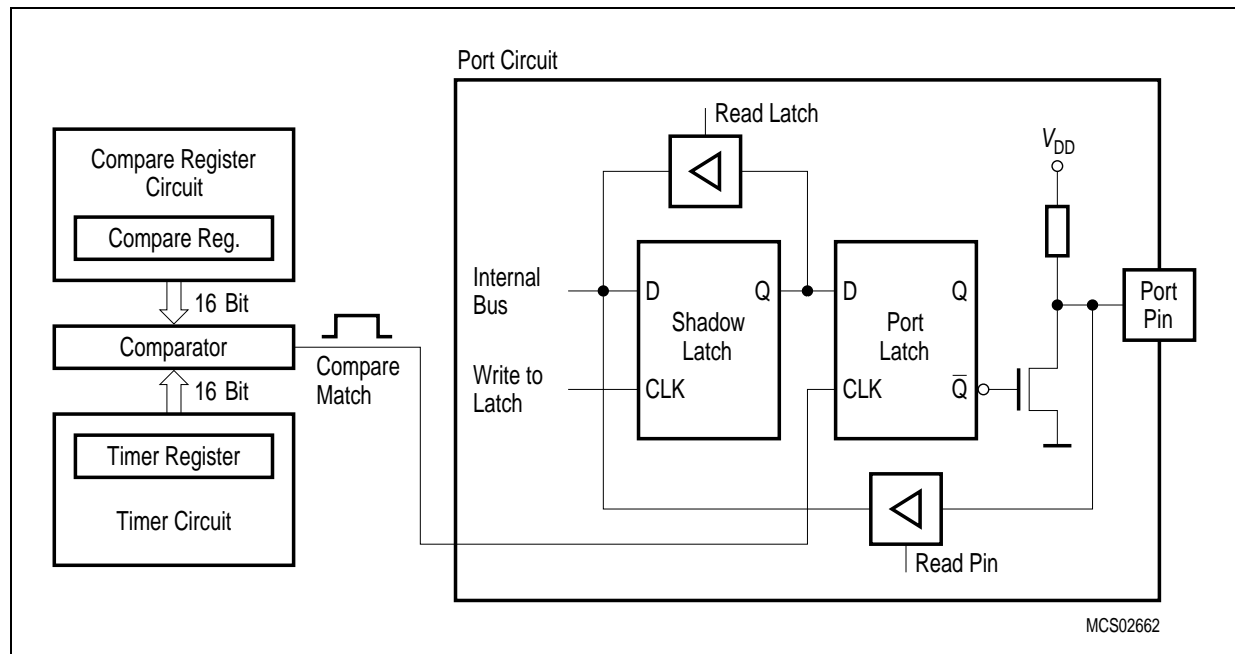

Figure 13
Compare Function in Compare Mode 1

Timer 2 Capture Modes

Each of the compare/capture registers CC1 to CC3 and the CRC register can be used to latch the current 16-bit value of the timer 2 registers TL2 and TH2. Two different modes are provided for this function.

In mode 0, the external event causing a capture is :

- for CC registers 1 to 3: a positive transition at pins CC1 to CC3 of port 1
- for the CRC register: a positive or negative transition at the corresponding pin, depending on the status of the bit I3FR in SFR T2CON.

In mode 1 a capture occurs in response to a write instruction to the low order byte of a capture register. The write-to-register signal (e.g. write-to-CRCL) is used to initiate a capture. The timer 2 contents will be latched into the appropriate capture register in the cycle following the write instruction. In this mode no interrupt request will be generated.

Serial Interface (USART)

The serial port is full duplex and can operate in four modes (one synchronous mode, three asynchronous modes) as illustrated in [Table 7](#).

Table 7
USART Operating Modes

Mode	SCON		Description
	SM0	SM1	
0	0	0	Shift register mode, fixed baud rate Serial data enters and exits through RxD; TxD outputs the shift clock; 8-bit are transmitted/received (LSB first)
1	0	1	8-bit UART, variable baud rate 10 bits are transmitted (through TxD) or received (at RxD)
2	1	0	9-bit UART, fixed baud rate 11 bits are transmitted (through TxD) or received (at RxD)
3	1	1	9-bit UART, variable baud rate Like mode 2

For clarification some terms regarding the difference between "baud rate clock" and "baud rate" should be mentioned. In the asynchronous modes the serial interfaces require a clock rate which is 16 times the baud rate for internal synchronization. Therefore, the baud rate generators/timers have to provide a "baud rate clock" (output signal in [Figure 14](#) to the serial interface which - there divided by 16 - results in the actual "baud rate". Further, the abbreviation f_{OSC} refers to the oscillator frequency (crystal or external clock operation).

The variable baud rates for modes 1 and 3 of the serial interface can be derived either from timer 1 or from a dedicated baud rate generator (see [Figure 14](#)).

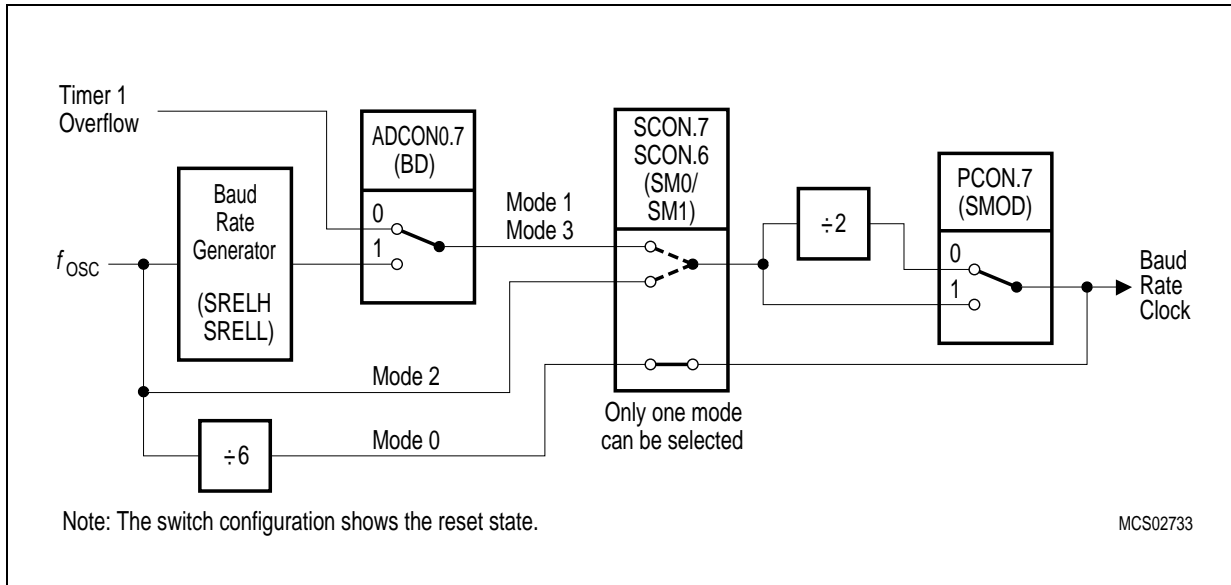

Figure 14
Block Diagram of Baud Rate Generation for the Serial Interface

Table 8 below lists the values/formulas for the baud rate calculation of the serial interface with its dependencies of the control bits BD and SMOD.

Table 8
Serial Interface - Baud Rate Dependencies

Serial Interface Operating Modes	Active Control Bits		Baud Rate Calculation
	BD	SMOD	
Mode 0 (Shift Register)	–	–	$f_{osc} / 6$
Mode 1 (8-bit UART) Mode 3 (9-bit UART)	0	X	Controlled by timer 1 overflow : $(2^{SMOD} \times \text{timer 1 overflow rate}) / 32$
	1	X	Controlled by baud rate generator $(2^{SMOD} \times f_{osc}) / (32 \times \text{baud rate generator overflow rate})$
Mode 2 (9-bit UART)	–	0	$f_{osc} / 32$
		1	$f_{osc} / 16$

CAN Controller (C505C and C505CA only)

The on-chip CAN controller, compliant to version 2.0B, is the functional heart which provides all resources that are required to run the standard CAN protocol (11-bit identifiers) as well as the extended CAN protocol (29-bit identifiers). It provides a sophisticated object layer to relieve the CPU of as much overhead as possible when controlling many different message objects (up to 15). This includes bus arbitration, resending of garbled messages, error handling, interrupt generation, etc. In order to implement the physical layer, external components have to be connected to the C505C/C505CA.

The internal bus interface connects the on-chip CAN controller to the internal bus of the microcontroller. The registers and data locations of the CAN interface are mapped to a specific 256 byte wide address range of the external data memory area (F700_H to F7FF_H) and can be accessed using MOVX instructions. **Figure 15** shows a block diagram of the on-chip CAN controller.

The **TX/RX Shift Register** holds the destuffed bit stream from the bus line to allow the parallel access to the whole data or remote frame for the acceptance match test and the parallel transfer of the frame to and from the Intelligent Memory.

The **Bit Stream Processor (BSP)** is a sequencer controlling the sequential data stream between the TX/RX Shift Register, the CRC Register, and the bus line. The BSP also controls the EML and the parallel data stream between the TX/RX Shift Register and the Intelligent Memory such that the processes of reception, arbitration, transmission, and error signalling are performed according to the CAN protocol. Note that the automatic retransmission of messages which have been corrupted by noise or other external error conditions on the bus line is handled by the BSP.

The **Cyclic Redundancy Check Register (CRC)** generates the Cyclic Redundancy Check code to be transmitted after the data bytes and checks the CRC code of incoming messages. This is done by dividing the data stream by the code generator polynomial.

The **Error Management Logic (EML)** is responsible for the fault confinement of the CAN device. Its counters, the Receive Error Counter and the Transmit Error Counter, are incremented and decremented by commands from the Bit Stream Processor. According to the values of the error counters, the CAN controller is set into the states error *active*, error *passive* and busoff.

The **Bit Timing Logic (BTL)** monitors the busline input RXDC and handles the busline related bit timing according to the CAN protocol. The BTL synchronizes on a *recessive* to *dominant* busline transition at *Start of Frame* (hard synchronization) and on any further *recessive* to *dominant* busline transition, if the CAN controller itself does not transmit a *dominant* bit (resynchronization). The BTL also provides programmable time segments to compensate for the propagation delay time and for phase shifts and to define the position of the Sample Point in the bit time. The programming of the BTL depends on the baudrate and on external physical delay times.

The **Intelligent Memory** (CAM/RAM array) provides storage for up to 15 message objects of maximum 8 data bytes length. Each of these objects has a unique identifier and its own set of control and status bits. After the initial configuration, the Intelligent Memory can handle the reception and transmission of data without further microcontroller actions.

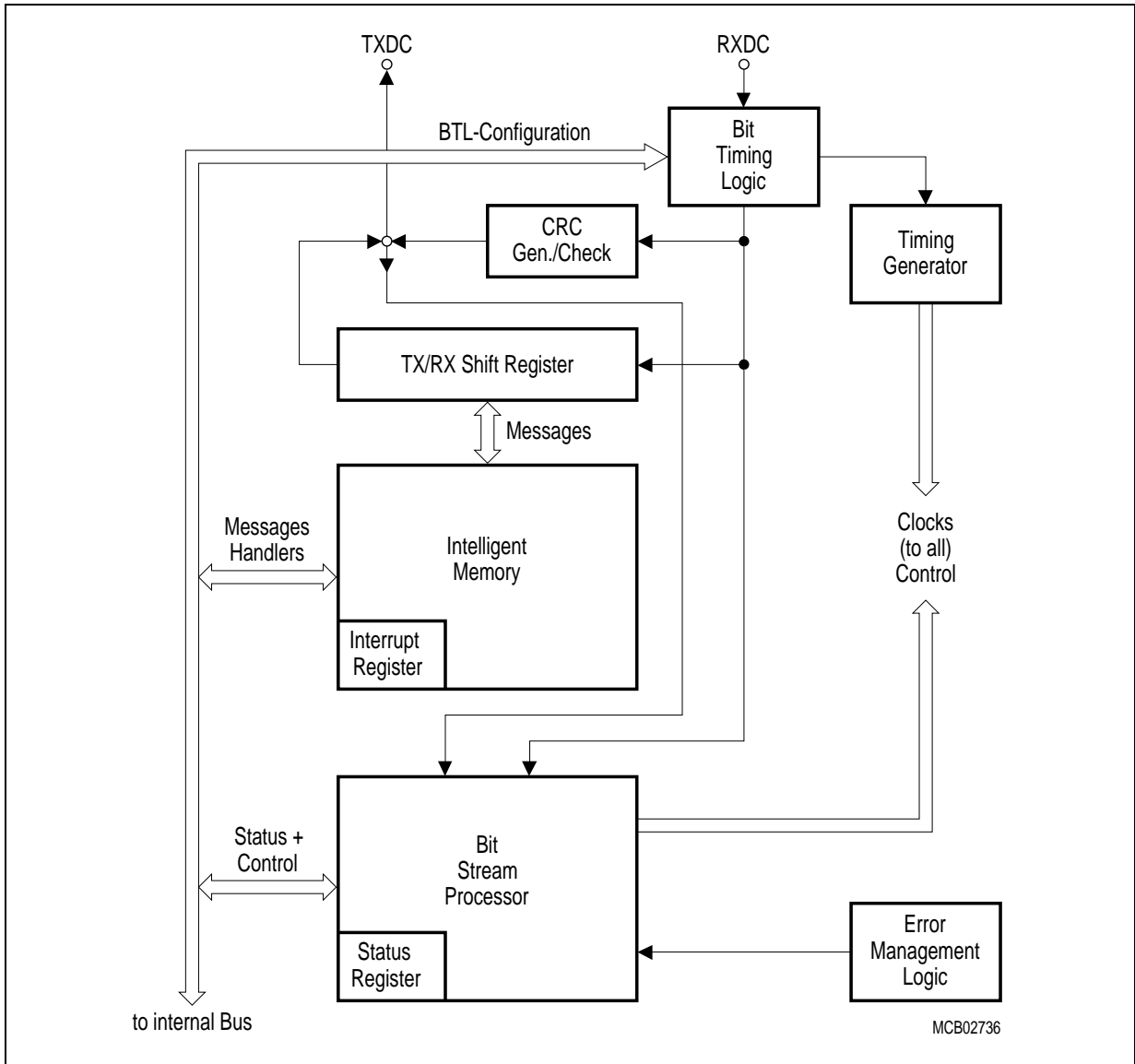

Figure 15
CAN Controller Block Diagram

CAN Controller Software Initialization

The very first step of the initialization is the CAN controller input clock selection. A divide-by-2 prescaler is enabled by default after reset (**Figure 16**). Setting bit CMOD (SYSCON.3) disables the prescaler. The purpose of the prescaler selection is:

- to ensure that the CAN controller is operable when f_{OSC} is over 10 MHz (bit CMOD =0)
- to achieve the maximum CAN baudrate of 1 Mbaud when f_{OSC} is 8 MHz (bit CMOD=1)

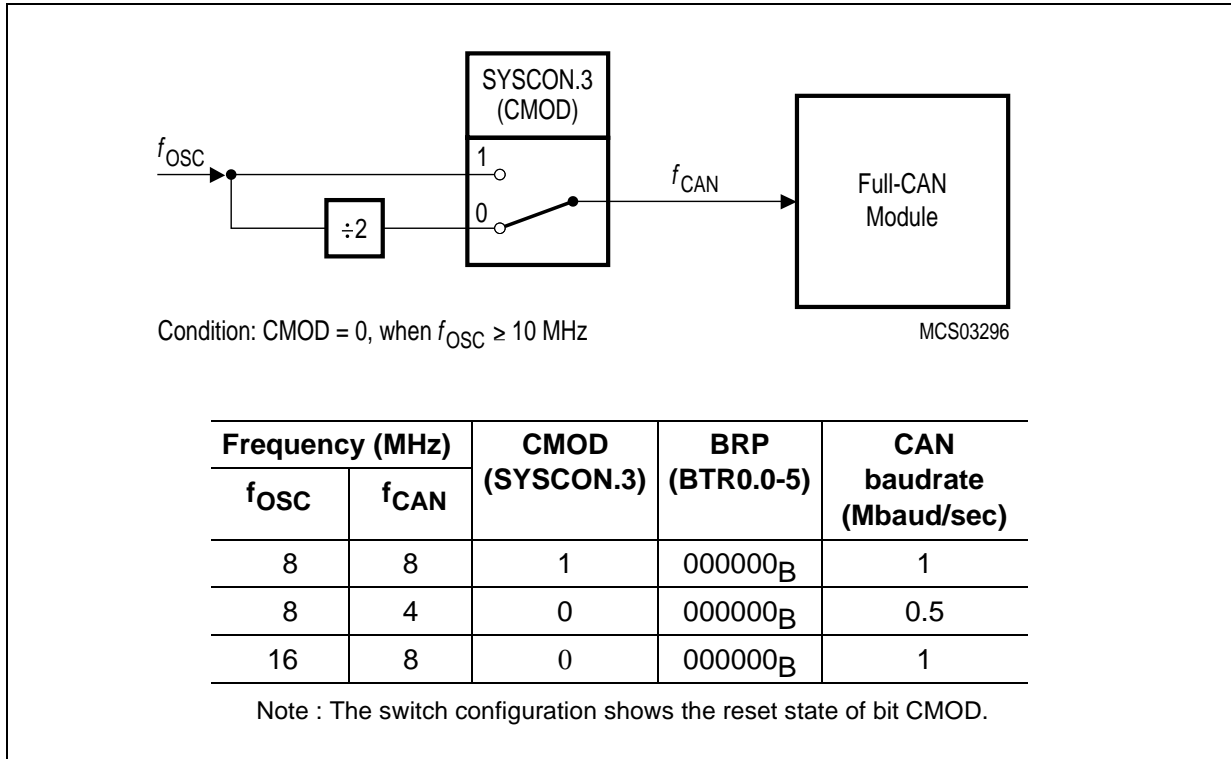

Figure 16
CAN controller Input Clock Selection

8-Bit A/D Converter (C505 and C505C only)

The C505/C505C includes a high performance / high speed 8-bit A/D converter (ADC) with 8 analog input channels. It operates with a successive approximation technique and provides the following features:

- 8 multiplexed input channels (port 1), which can also be used as digital outputs/inputs
- 8-bit resolution
- Internal start-of-conversion trigger
- Interrupt request generation after each conversion
- Single or continuous conversion mode

The 8-bit ADC uses two clock signals for operation : the conversion clock f_{ADC} ($=1/t_{ADC}$) and the input clock f_{IN} ($1/t_{IN}$). f_{ADC} is derived from the C505 system clock f_{OSC} which is applied at the XTAL pins via the ADC clock prescaler as shown in **Figure 17**. The input clock is equal to f_{OSC} . The conversion clock f_{ADC} is limited to a maximum frequency of 1.25 MHz. Therefore, the ADC clock prescaler must be programmed to a value which assures that the conversion clock does not exceed 1.25 MHz. The prescaler ratio is selected by the bits ADCL1 and ADCL0 of SFR ADCON1.

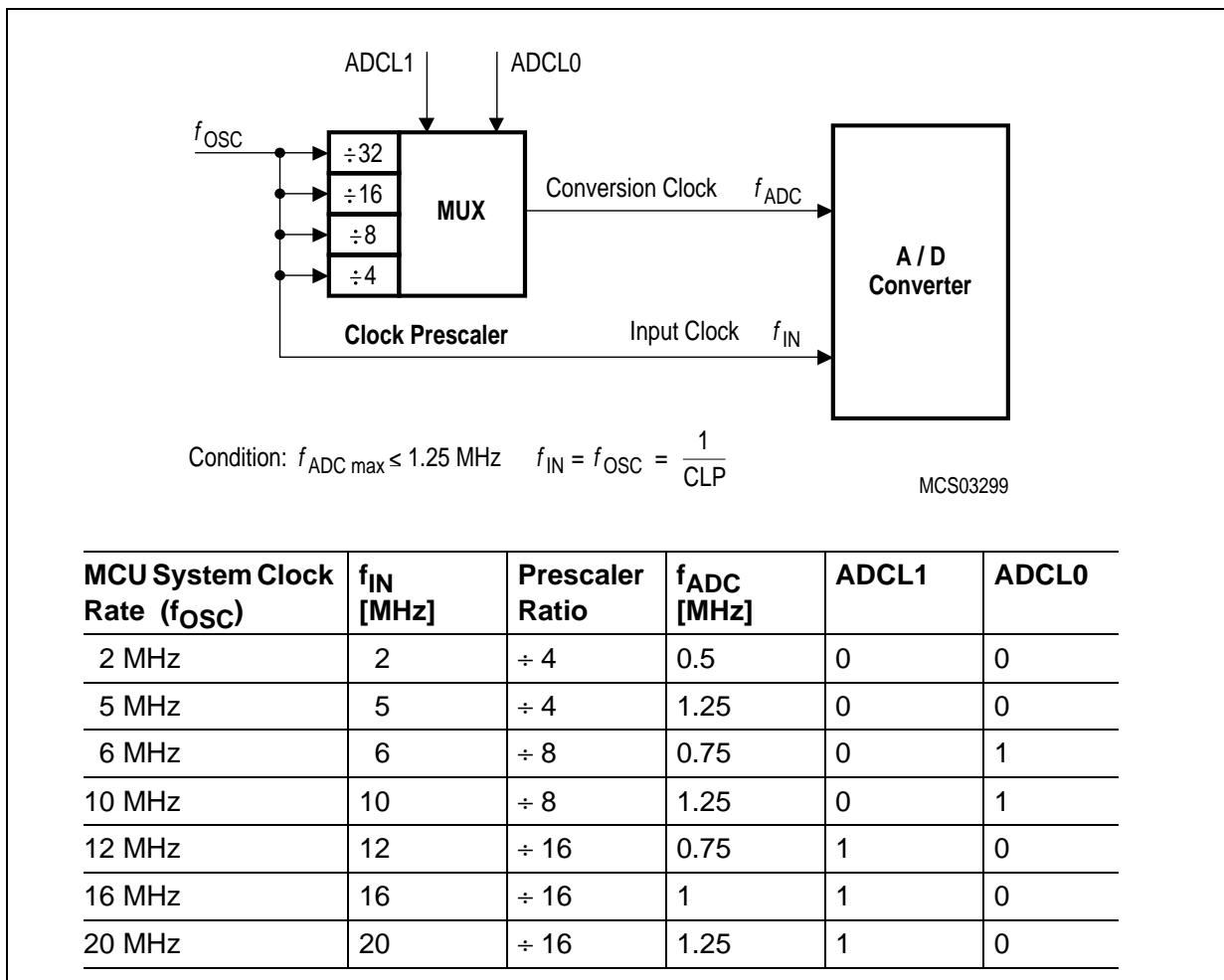

Figure 17
8-Bit A/D Converter Clock Selection

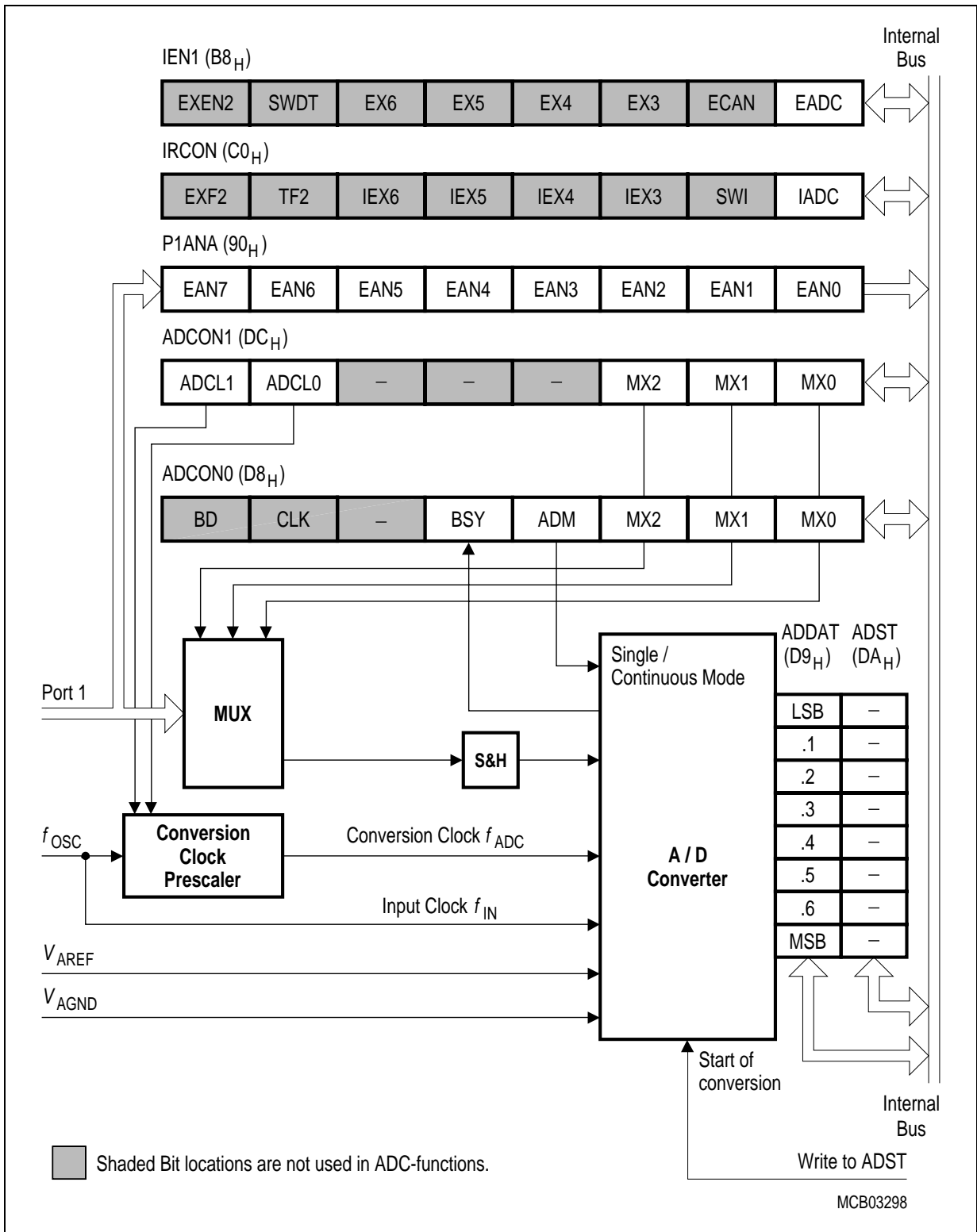

Figure 18
Block Diagram of the 8-Bit A/D Converter

10-Bit A/D Converter (C505A and C505CA only)

The C505A/C505CA includes a high performance / high speed 10-bit A/D-Converter (ADC) with 8 analog input channels. It operates with a successive approximation technique and uses self calibration mechanisms for reduction and compensation of offset and linearity errors. The A/D converter provides the following features:

- 8 multiplexed input channels (port 1), which can also be used as digital inputs/outputs
- 10-bit resolution
- Single or continuous conversion mode
- Internal start-of-conversion trigger capability
- Interrupt request generation after each conversion
- Using successive approximation conversion technique via a capacitor array
- Built-in hidden calibration of offset and linearity errors

The 10-bit ADC uses two clock signals for operation : the conversion clock f_{ADC} ($=1/t_{ADC}$) and the input clock f_{IN} ($=1/t_{IN}$). f_{ADC} is derived from the C505 system clock f_{OSC} which is applied at the XTAL pins. The input clock f_{IN} is equal to f_{OSC} . The conversion f_{ADC} clock is limited to a maximum frequency of 2 MHz. Therefore, the ADC clock prescaler must be programmed to a value which assures that the conversion clock does not exceed 2 MHz. The prescaler ratio is selected by the bits ADCL1 and ADCL0 of SFR ADCON1.

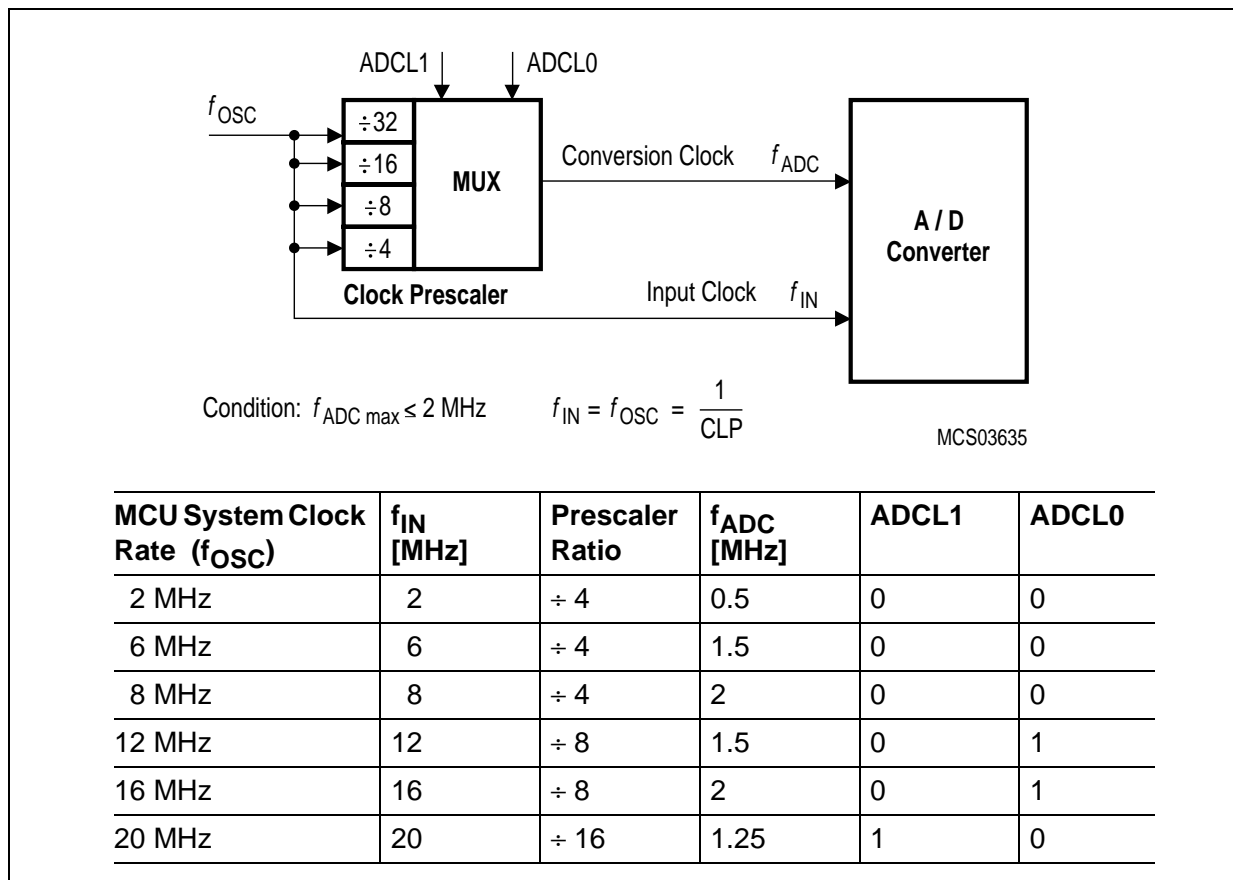

Figure 19
10-Bit A/D Converter Clock Selection

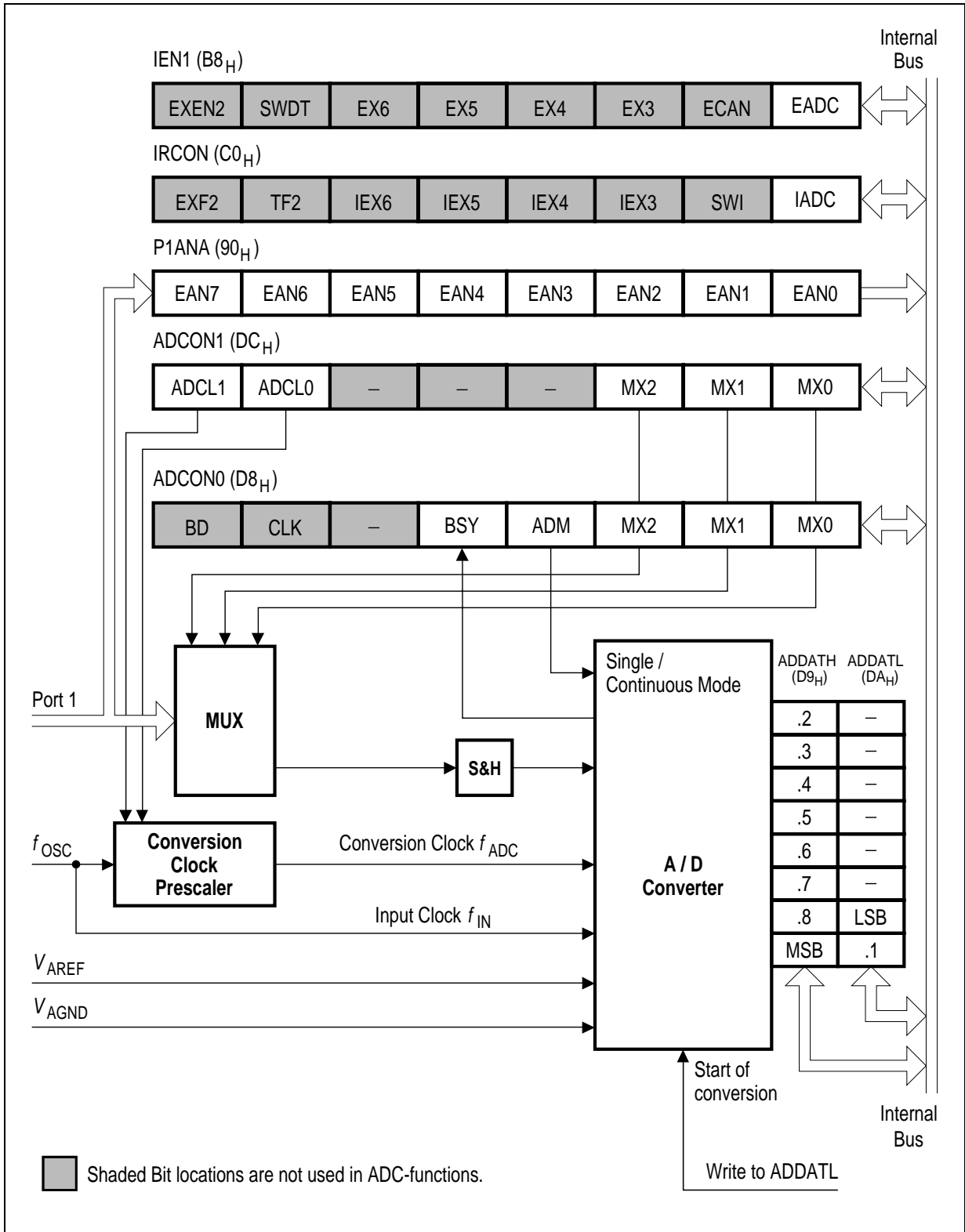

Figure 20
Block Diagram of the 10-Bit A/D Converter

Interrupt System

The C505 provides 12 interrupt vectors with four priority levels. Five interrupt requests can be generated by the on-chip peripherals (timer 0, timer 1, timer 2, serial interface, A/D converter). One interrupt can be generated by the CAN controller (C505C and C505CA only) or by a software setting and in this case the interrupt vector is the same. Six interrupts may be triggered externally (P3.2/ $\overline{\text{INT0}}$, P3.3/ $\overline{\text{INT1}}$, P1.0/ $\overline{\text{AN0}}/\overline{\text{INT3}}/\text{CC0}$, P1.1/ $\overline{\text{AN1}}/\overline{\text{INT4}}/\text{CC1}$, P1.2/ $\overline{\text{AN2}}/\overline{\text{INT5}}/\text{CC2}$, P1.3/ $\overline{\text{AN3}}/\overline{\text{INT6}}/\text{CC3}$). Additionally, the P1.5/ $\overline{\text{AN5}}/\text{T2EX}$ can trigger an interrupt. The wake-up from power-down mode interrupt has a special functionality which allows to exit from the software power-down mode by a short low pulse at either pin P3.2/ $\overline{\text{INT0}}$ or the pin P4.1/ $\overline{\text{RXDC}}$.

Figure 21 to **Figure 23** give a general overview of the interrupt sources and illustrate the request and the control flags which are described in the next sections. **Table 9** lists all interrupt sources with their request flags and interrupt vector addresses.

Table 9
Interrupt Source and Vectors

Interrupt Source	Interrupt Vector Address	Interrupt Request Flags
External Interrupt 0	0003 _H	IE0
Timer 0 Overflow	000B _H	TF0
External Interrupt 1	0013 _H	IE1
Timer 1 Overflow	001B _H	TF1
Serial Channel	0023 _H	RI / TI
Timer 2 Overflow / Ext. Reload	002B _H	TF2 / EXF2
A/D Converter	0043 _H	IADC
CAN Controller / Software Interrupt	004B _H	– / SWI
External interrupt 3	0053 _H	IEX3
External Interrupt 4	005B _H	IEX4
External Interrupt 5	0063 _H	IEX5
External interrupt 6	006B _H	IEX6
Wake-up from power-down mode	007B _H	–

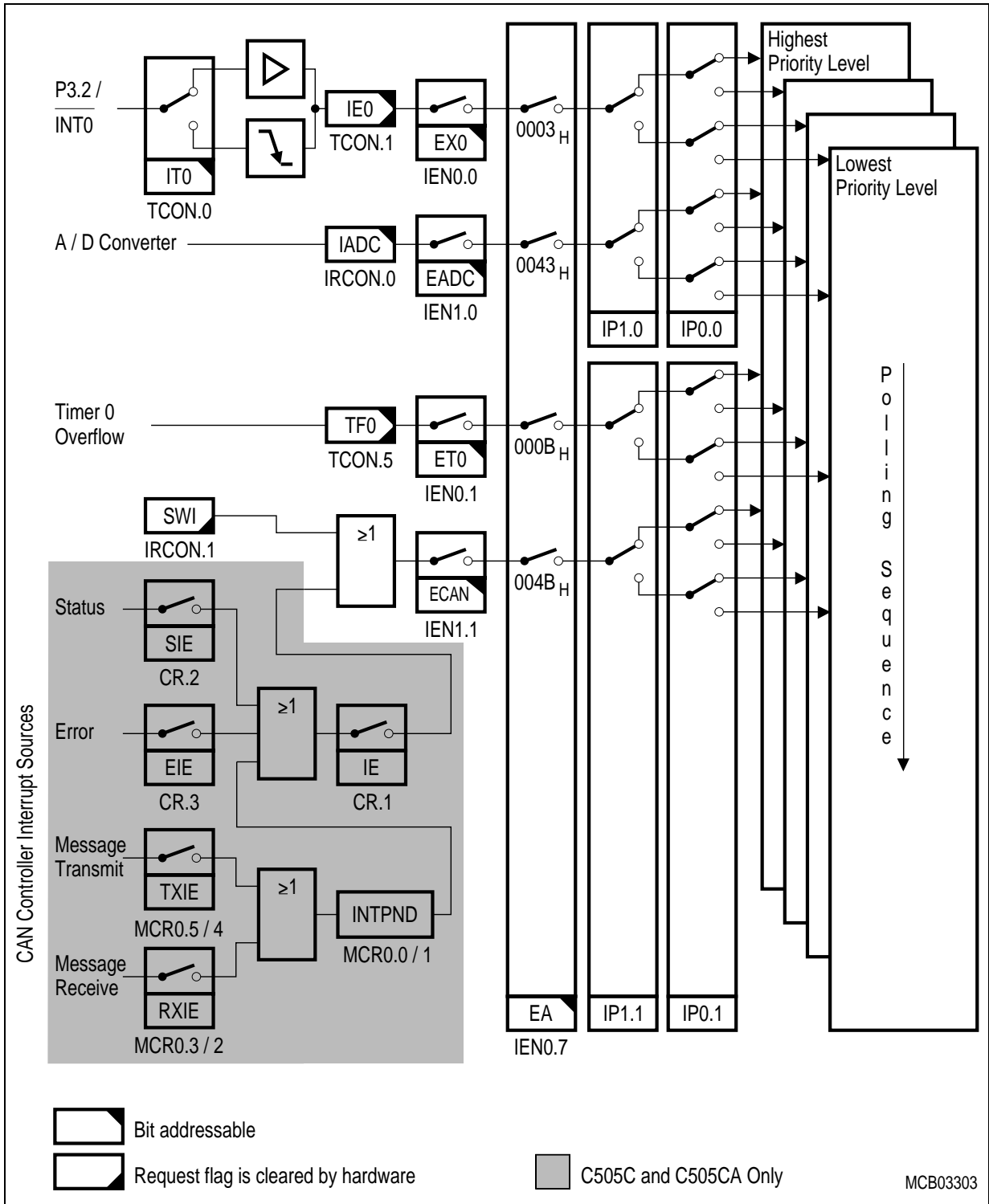

Figure 21
Interrupt Structure, Overview Part 1

Note: Each of the 15 CAN controller message objects (C505C and C505CA only), shown in the shaded area of [Figure 21](#) provides the bits/flags.

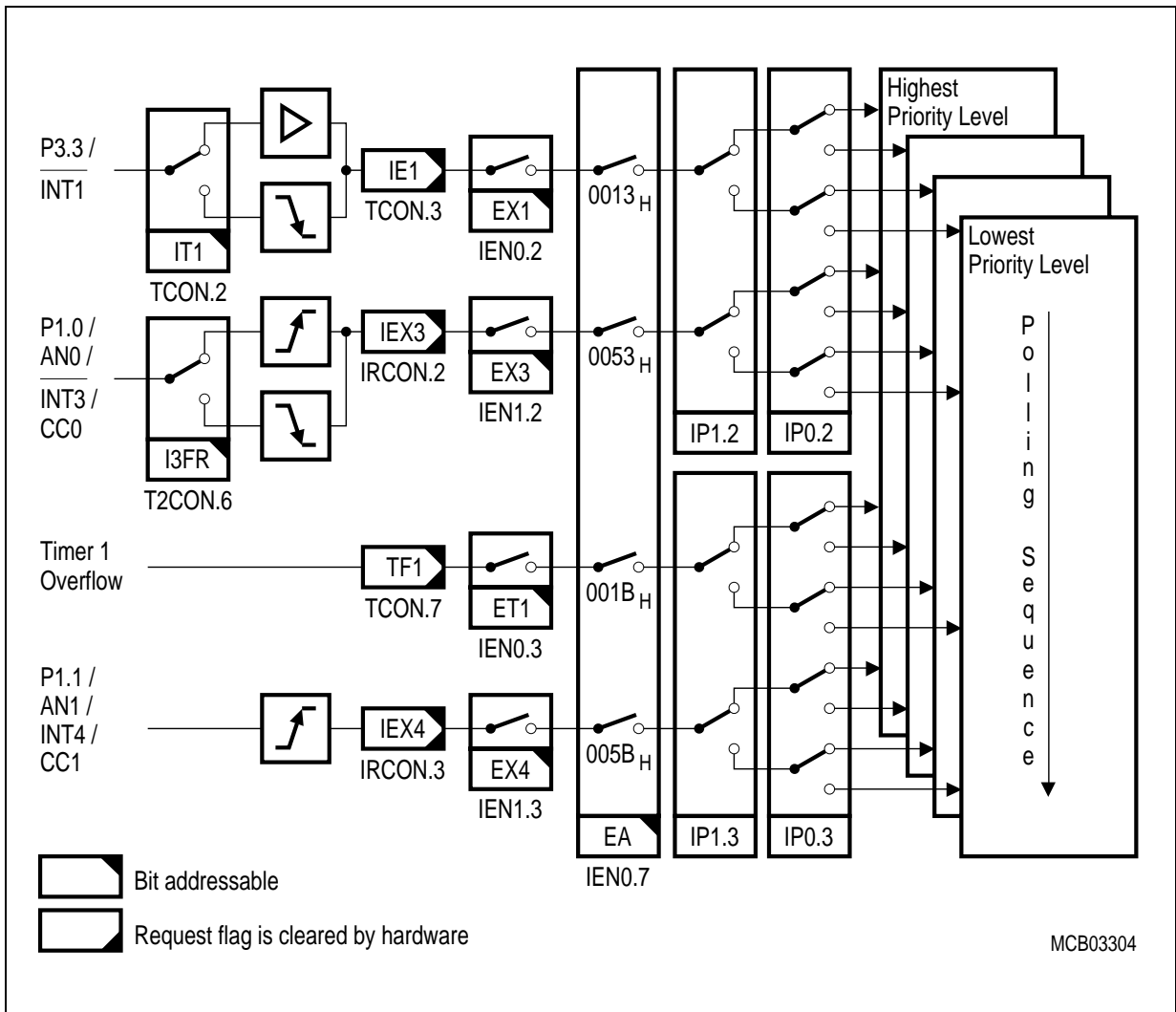

Figure 22
Interrupt Structure, Overview Part 2

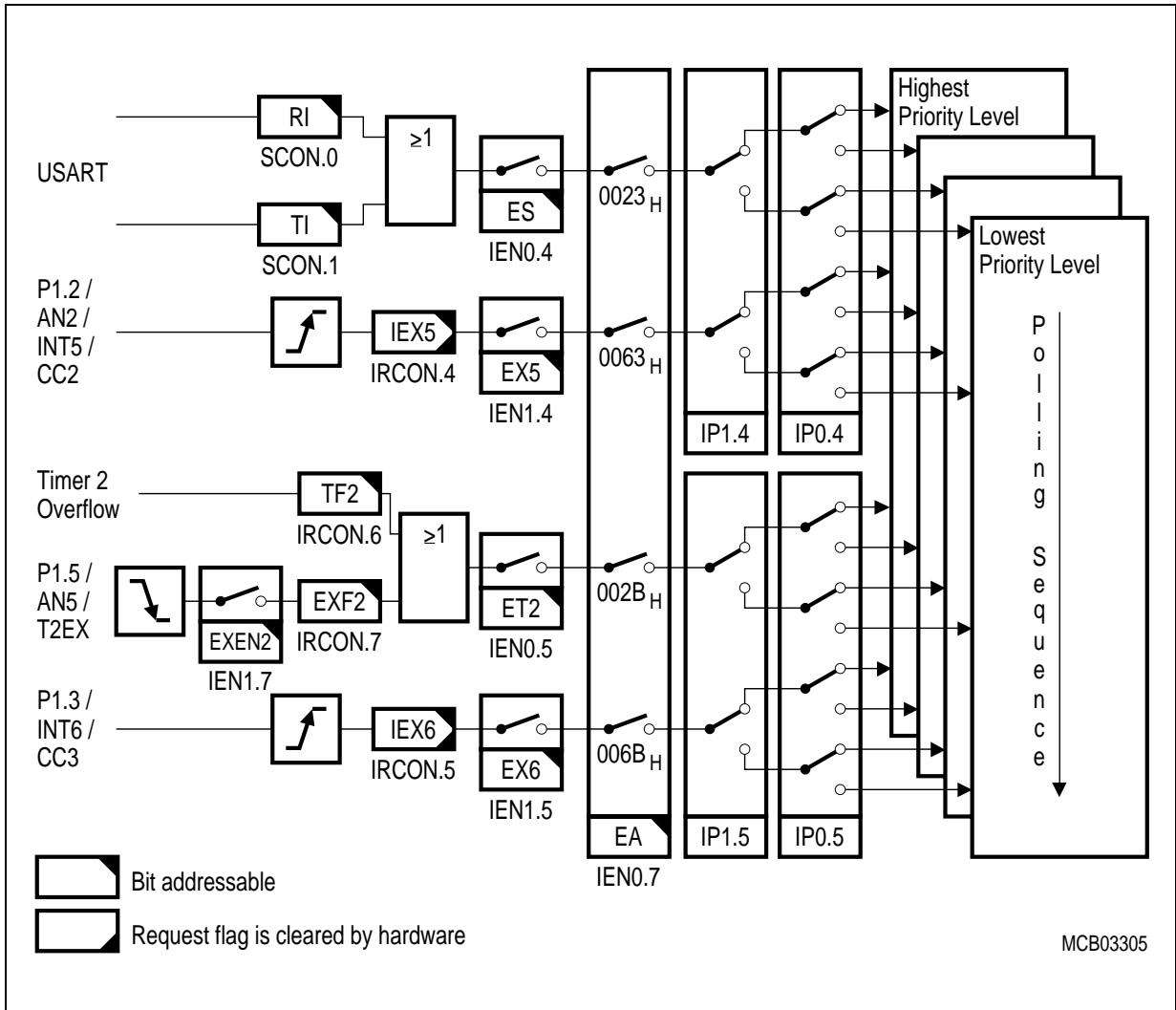

Figure 23
Interrupt Structure, Overview Part 3

Fail Save Mechanisms

The C505 offers enhanced fail safe mechanisms, which allow an automatic recovery from software upset or hardware failure :

- a programmable watchdog timer (WDT), with variable time-out period from 192 μs up to approx. 393.2 ms at 16 MHz (314.5 ms at 20 MHz).
- an oscillator watchdog (OWD) which monitors the on-chip oscillator and forces the microcontroller into reset state in case the on-chip oscillator fails; it also provides the clock for a fast internal reset after power-on.

The watchdog timer in the C505 is a 15-bit timer, which is incremented by a count rate of $f_{OSC}/12$ upto $f_{OSC}/192$. The system clock of the C505 is divided by two prescalers, a divide-by-two and a divide-by-16 prescaler. For programming of the watchdog timer overflow rate, the upper 7 bits of the watchdog timer can be written. **Figure 24** shows the block diagram of the watchdog timer unit.

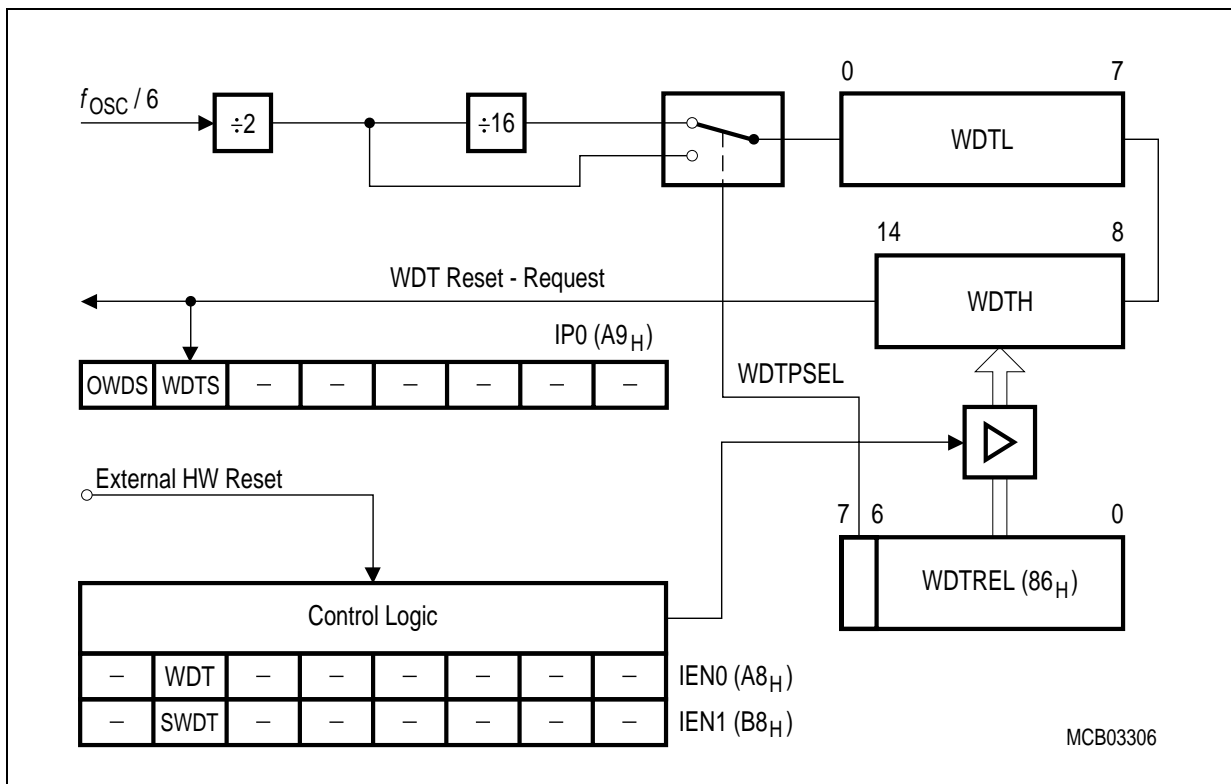

Figure 24
Block Diagram of the Programmable Watchdog Timer

The watchdog timer can be started by software (bit SWDT in SFR IEN1) but it cannot be stopped during active mode of the device. If the software fails to refresh the running watchdog timer an internal reset will be initiated on watchdog timer overflow. For refreshing of the watchdog timer the content of the SFR WDTREL is transferred to the upper 7-bit of the watchdog timer. The refresh sequence consists of two consecutive instructions which set the bits WDT and SWDT each. The reset cause (external reset or reset caused by the watchdog) can be examined by software (flag WDTs). It must be noted, however, that the watchdog timer is halted during the idle mode and power down mode of the processor.

Oscillator Watchdog

The oscillator watchdog unit serves for three functions:

- **Monitoring of the on-chip oscillator's function**

The watchdog supervises the on-chip oscillator's frequency; if it is lower than the frequency of the auxiliary RC oscillator in the watchdog unit, the internal clock is supplied by the RC oscillator and the device is brought into reset; if the failure condition disappears (i.e. the on-chip oscillator has a higher frequency than the RC oscillator), the part, in order to allow the oscillator to stabilize, executes a final reset phase of typ. 1 ms; then the oscillator watchdog reset is released and the part starts program execution from address 0000_H again.

- **Fast internal reset after power-on**

The oscillator watchdog unit provides a clock supply for the reset before the on-chip oscillator has started. The oscillator watchdog unit also works identically to the monitoring function.

- **Control of external wake-up from software power-down mode**

When the power-down mode is left by a low level at the P3.2/ $\overline{\text{INT0}}$ pin or the P4.1/RXDC pin, the oscillator watchdog unit assures that the microcontroller resumes operation (execution of the power-down wake-up interrupt) with the nominal clock rate. In the power-down mode the RC oscillator and the on-chip oscillator are stopped. Both oscillators are started again when power-down mode is released. When the on-chip oscillator has a higher frequency than the RC oscillator, the microcontroller starts program execution by processing a power down interrupt after a final delay of typ. 1 ms in order to allow the on-chip oscillator to stabilize.

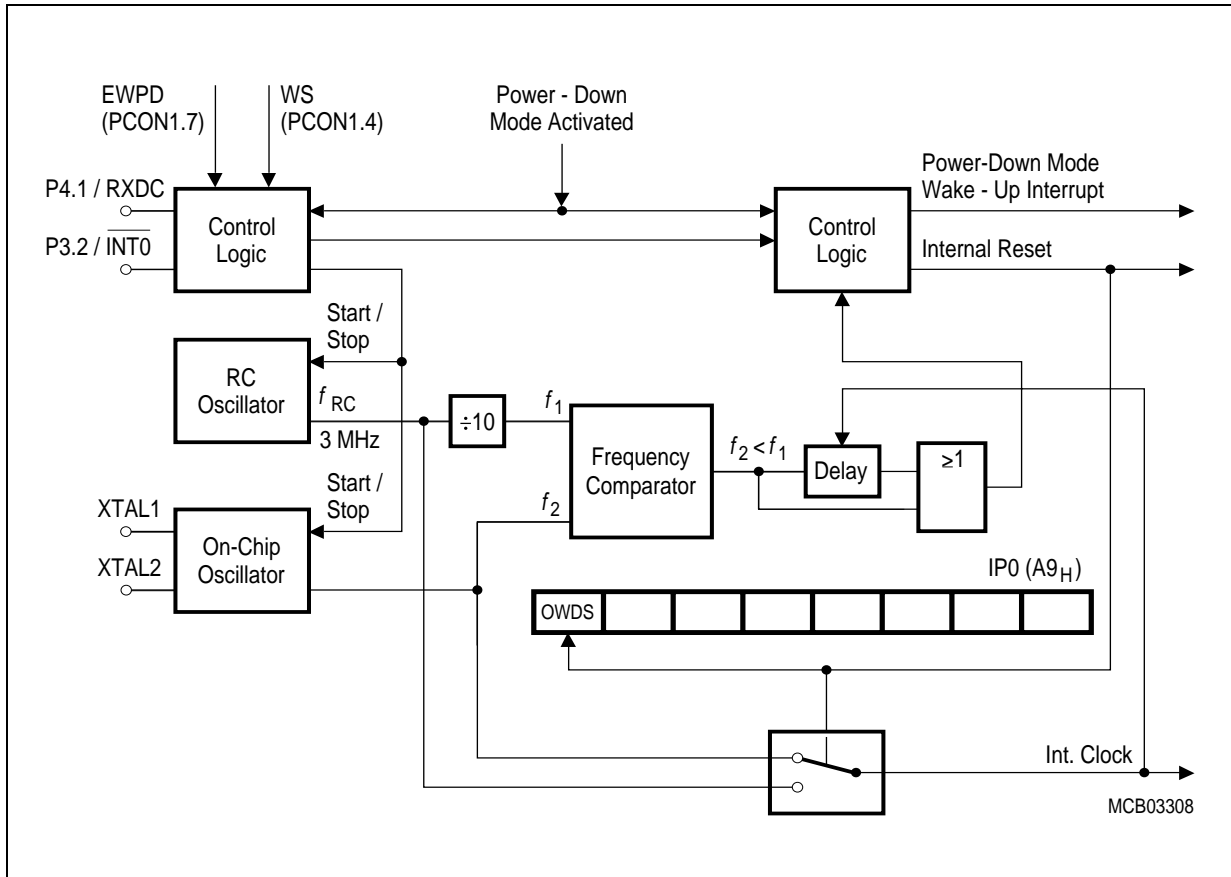

Figure 25
Functional Block Diagram of the Oscillator Watchdog

Power Saving Modes

The C505 provides two basic power saving modes, the idle mode and the power down mode. Additionally, a slow down mode is available. This power saving mode reduces the internal clock rate in normal operating mode and it can be also used for further power reduction in idle mode.

– **Idle mode**

In the idle mode the main oscillator of the C505 continues to run, but the CPU is gated off from the clock signal. All peripheral units are further provided with the clock. The CPU status is preserved in its entirety. The idle mode can be terminated by any enabled interrupt of a peripheral unit or by a hardware reset.

– **Power down mode**

The operation of the C505 is completely stopped and the oscillator is turned off. This mode is used to save the contents of the internal RAM with a very low standby current. Power down mode is entered by software and can be left by reset or by a short low pulse at pin P3.2/ $\overline{\text{INT0}}$ or P4.1/RXDC.

– **Slow down mode**

The controller keeps up the full operating functionality, but its normal clock frequency is internally divided by 32. This slows down all parts of the controller, the CPU and all peripherals, to 1/32-th of their normal operating frequency. Slowing down the frequency significantly reduces power consumption.

In the power down mode of operation, V_{DD} can be reduced to minimize power consumption. It must be ensured, however, that V_{DD} is not reduced before the power down mode is invoked, and that V_{DD} is restored to its normal operating level, before the power down mode is terminated. **Table 10** gives a general overview of the entry and exit procedures of the power saving modes.

Table 10
Power Saving Modes Overview

Mode	Entering (Instruction Example)	Leaving by	Remarks
Idle Mode	ORL PCON, #01H ORL PCON, #20H	Ocurrence of an interrupt from a peripheral unit	CPU clock is stopped; CPU maintains their data; peripheral units are active (if enabled) and provided with clock
		Hardware Reset	
Power Down Mode	ORL PCON, #02H ORL PCON, #40H	Hardware Reset	Oscillator is stopped; contents of on-chip RAM and SFR's are maintained;
		Short low pulse at pin P3.2/ $\overline{\text{INT0}}$ or P4.1/RXDC	
Slow Down Mode	ORL PCON, #10H	ANL PCON, #0EFH or Hardware Reset	Oscillator frequency is reduced to 1/32 of its nominal frequency

OTP Memory Operation (C505A-4E and C505CA-4E only)

The C505A-4E/C505CA-4E contains a 32K byte one-time programmable (OTP) program memory. With the C505A-4E/C505CA-4E fast programming cycles are achieved (1 byte in 100 μ sec). Also several levels of OTP memory protection can be selected.

For programming of the device, the C505A-4E/C505CA-4E must be put into the programming mode. This typically is done not in-system but in a special programming hardware. In the programming mode the C505A-4E/C505CA-4E operates as a slave device similar as an EPROM standalone memory device and must be controlled with address/data information, control lines, and an external 11.5V programming voltage. **Figure 26** shows the pins of the C505A-4E/C505CA-4E which are required for controlling of the OTP programming mode.

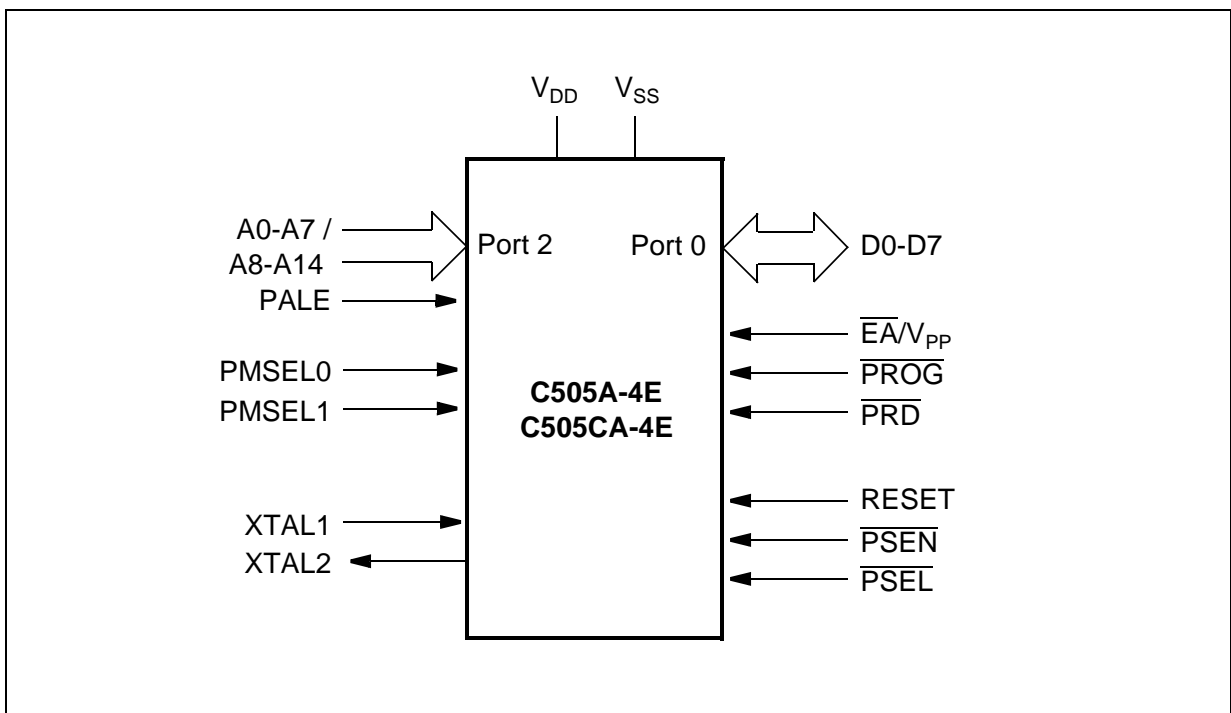

Figure 26
Programming Mode Configuration

Pin Configuration in Programming Mode

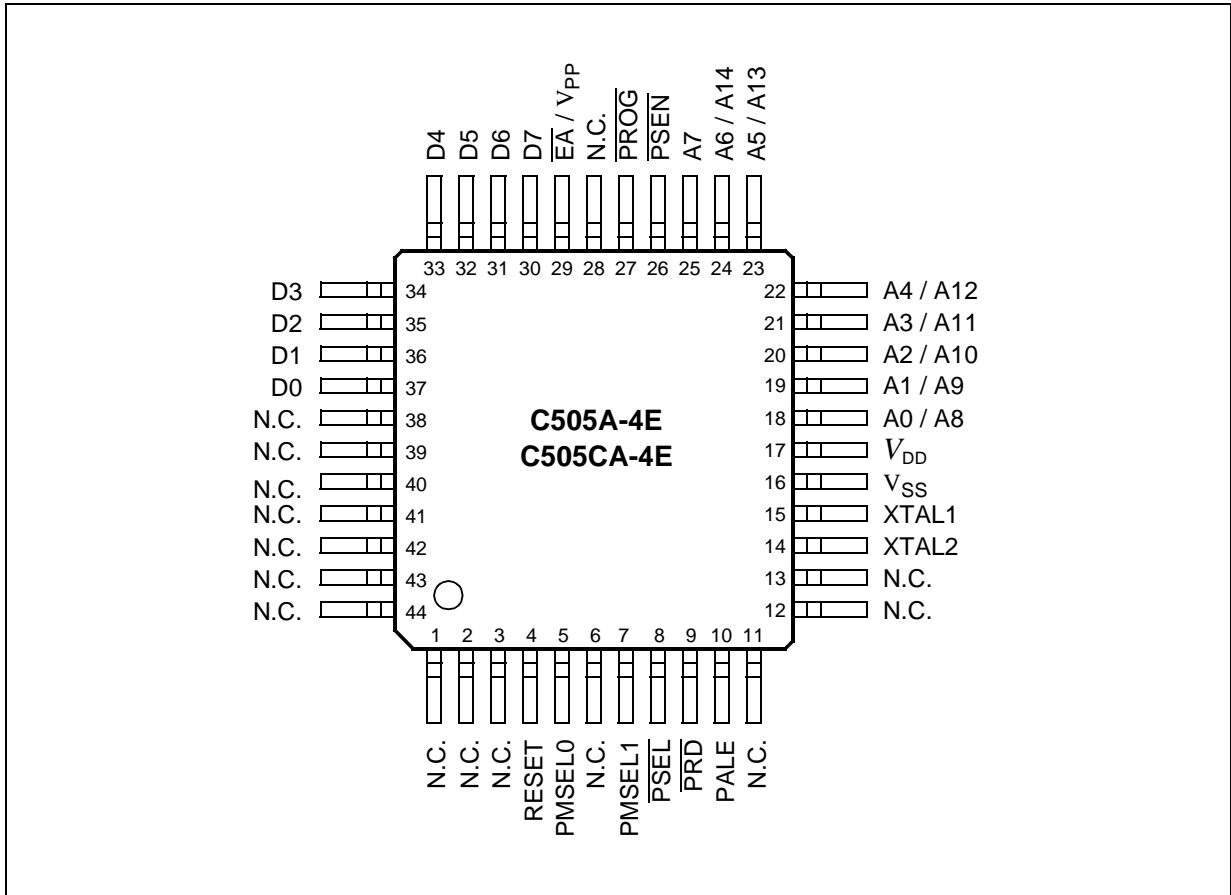

Figure 27
P-MQFP-44 Pin Configuration of the C505A-4E/C505CA-4E in Programming Mode (Top View)

The following **Table 11** contains the functional description of all C505A-4E/C505CA-4E pins which are required for OTP memory programming.

Table 11
Pin Definitions and Functions in Programming Mode

Symbol	Pin Number	I/O *)	Function															
RESET	4	I	Reset This input must be at static "1" (active) level during the whole programming mode.															
PMSEL0 PMSEL1	5 7	I I	Programming mode selection pins These pins are used to select the different access modes in programming mode. PMSEL1,0 must satisfy a setup time to the rising edge of PALE. When the logic level of PMSEL1,0 is changed, PALE must be at low level. <table border="1" data-bbox="646 842 1411 1079"> <thead> <tr> <th>PMSEL1</th> <th>PMSEL0</th> <th>Access Mode</th> </tr> </thead> <tbody> <tr> <td>0</td> <td>0</td> <td>Reserved</td> </tr> <tr> <td>0</td> <td>1</td> <td>Read version bytes</td> </tr> <tr> <td>1</td> <td>0</td> <td>Program/read lock bits</td> </tr> <tr> <td>1</td> <td>1</td> <td>Program/read OTP memory byte</td> </tr> </tbody> </table>	PMSEL1	PMSEL0	Access Mode	0	0	Reserved	0	1	Read version bytes	1	0	Program/read lock bits	1	1	Program/read OTP memory byte
PMSEL1	PMSEL0	Access Mode																
0	0	Reserved																
0	1	Read version bytes																
1	0	Program/read lock bits																
1	1	Program/read OTP memory byte																
PSEL	8	I	Basic programming mode select This input is used for the basic programming mode selection and must be switched according Figure 28 .															
PRD	9	I	Programming mode read strobe This input is used for read access control for OTP memory read, Version Register read, and lock bit read operations.															
PALE	10	I	Programming address latch enable PALE is used to latch the high address lines. The high address lines must satisfy a setup and hold time to/from the falling edge of PALE. PALE must be at low level when the logic level of PMSEL1,0 is changed.															
XTAL2	14	O	XTAL2 Output of the inverting oscillator amplifier.															
XTAL1	15	I	XTAL1 Input to the oscillator amplifier.															
V _{SS}	16	–	Circuit ground potential must be applied in programming mode.															
V _{DD}	17	–	Power supply terminal must be applied in programming mode.															

*) I = Input
O = Output

Table 11
Pin Definitions and Functions in Programming Mode (cont'd)

Symbol	Pin Number	I/O)	Function
P2.0-7	18-25	I	Address lines P2.0-7 are used as multiplexed address input lines A0-A7 and A8-A14. A8-A14 must be latched with PALE.
$\overline{\text{PSEN}}$	26	I	Program store enable This input must be at static "0" level during the whole programming mode.
$\overline{\text{PROG}}$	27	I	Programming mode write strobe This input is used in programming mode as a write strobe for OTP memory program, and lock bit write operations During basic programming mode selection a low level must be applied to $\overline{\text{PROG}}$.
$\overline{\text{EA}}/V_{\text{PP}}$	29	–	External Access / Programming voltage This pin must be at 11.5V (V_{PP}) voltage level during programming of an OTP memory byte or lock bit. During an OTP memory read operation this pin must be at V_{IH} high level. This pin is also used for basic programming mode selection. At basic programming mode selection a low level must be applied to $\overline{\text{EA}}/V_{\text{PP}}$.
D7-0	30-37	I/O	Data lines 0-7 During programming mode, data bytes are transferred via the bidirectional port 0 data lines.
N.C.	1-3, 6, 11-13, 28, 38-44	–	Not Connected These pins should not be connected in programming mode.

*) I = Input
 O = Output

Basic Programming Mode Selection

The basic programming mode selection scheme is shown in [Figure 28](#).

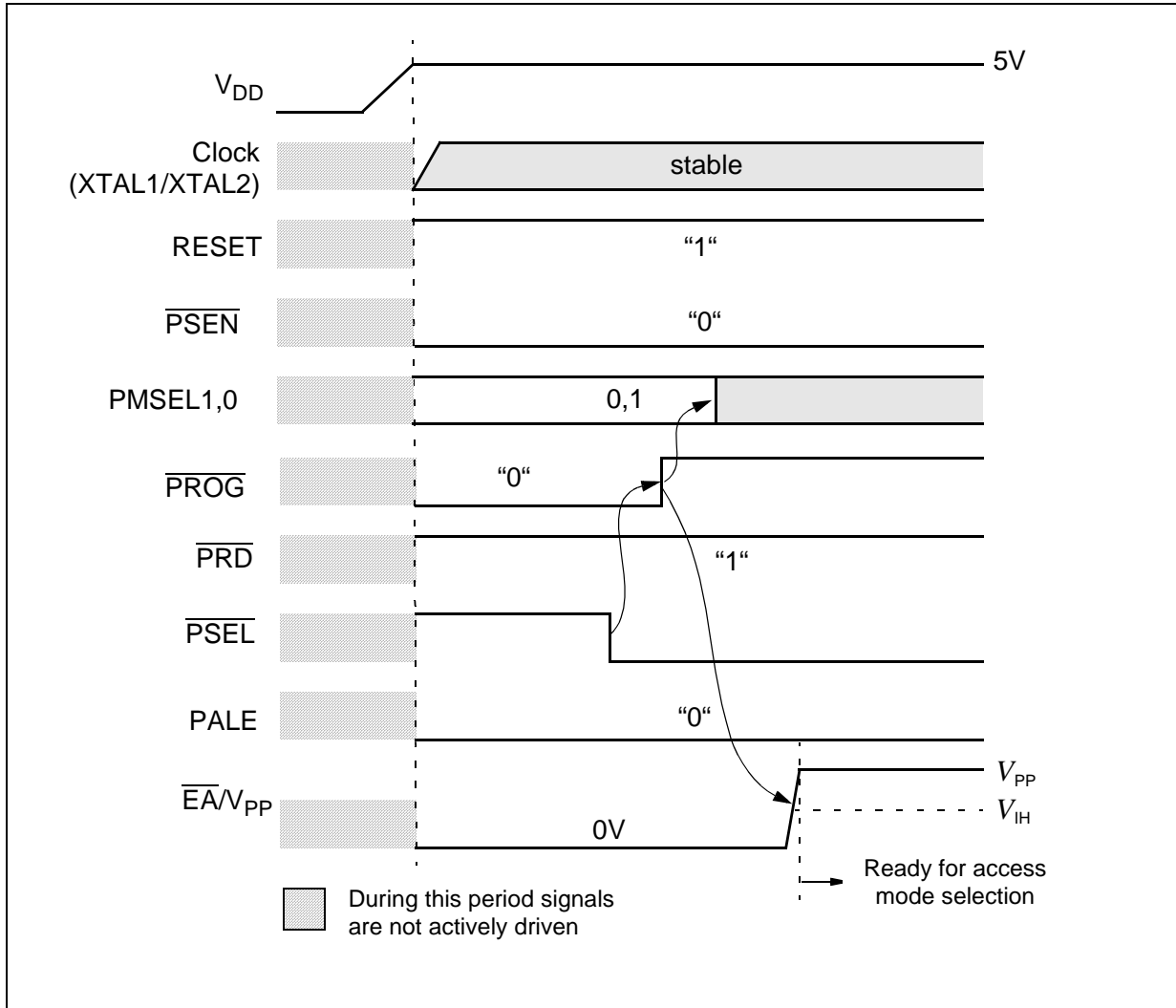

Figure 28
Basic Programming Mode Selection

Table 12
Access Modes Selection

Access Mode	\overline{EA}/V_{PP}	\overline{PROG}	\overline{PRD}	PMSEL		Address (Port 2)	Data (Port 0)
				1	0		
Program OTP memory byte	V_{PP}		H	H	H	A0-7	D0-7
Read OTP memory byte	V_{IH}	H				A8-14	
Program OTP lock bits	V_{PP}		H	H	L	–	D1,D0 see Table 13
Read OTP lock bits	V_{IH}	H					
Read OTP version byte	V_{IH}	H		L	H	Byte addr. of sign. byte	D0-7

Lock Bits Programming / Read

The C505A-4E/C505CA-4E has two programmable lock bits which, when programmed according to [Table 13](#), provide four levels of protection for the on-chip OTP code memory. The state of the lock bits can also be read.

Table 13
Lock Bit Protection Types

Lock Bits at D1,D0		Protection Level	Protection Type
D1	D0		
1	1	Level 0	The OTP lock feature is disabled. During normal operation of the C505A-4E/C505CA-4E, the state of the \overline{EA} pin is not latched on reset.
1	0	Level 1	During normal operation of the C505A-4E/C505CA-4E, MOV _C instructions executed from external program memory are disabled from fetching code bytes from internal memory. \overline{EA} is sampled and latched on reset. An OTP memory read operation is only possible using the ROM/OTP verification mode 2 for protection level 1. Further programming of the OTP memory is disabled (reprogramming security).
0	1	Level 2	Same as level 1, but also OTP memory read operation using OTP verification mode is disabled.
0	0	Level 3	Same as level 2; but additionally external code execution by setting \overline{EA} =low during normal operation of the C505A-4E/C505CA-4E is no more possible. External code execution, which is initiated by an internal program (e.g. by an internal jump instruction above the ROM boundary), is still possible.

Absolute Maximum Ratings

Parameter	Symbol	Limit Values		Unit	Notes
		min.	max.		
Storage temperature	T_{ST}	- 65	150	°C	-
Voltage on V_{DD} pins with respect to ground (V_{SS})	V_{DD}	- 0.5	6.5	V	-
Voltage on any pin with respect to ground (V_{SS})	V_{IN}	- 0.5	$V_{DD} + 0.5$	V	-
Input current on any pin during overload condition		- 10	10	mA	-
Absolute sum of all input currents during overload condition			100 mA	mA	-
Power dissipation	P_{DISS}		1	W	-

Note: Stresses above those listed under “Absolute Maximum Ratings” may cause permanent damage of the device. This is a stress rating only and functional operation of the device at these or any other conditions above those indicated in the operational sections of this specification is not implied. Exposure to absolute maximum rating conditions for longer periods may affect device reliability. During absolute maximum rating overload conditions ($V_{IN} > V_{DD}$ or $V_{IN} < V_{SS}$) the voltage on V_{DD} pins with respect to ground (V_{SS}) must not exceed the values defined by the absolute maximum ratings.

Operating Conditions

Parameter	Symbol	Limit Values		Unit	Notes
		min.	max.		
Supply voltage	V_{DD}	4.25	5.5	V	Active mode, $f_{osc\ max} = 20\ MHz$
		2	5.5	V	PowerDown mode
Ground voltage	V_{SS}	0		V	Reference voltage
Ambient temperature				$^{\circ}C$	–
SAB-C505	T_A	0	70		
SAF-C505	T_A	-40	85		
SAH-C505	T_A	-40	110		
SAK-C505	T_A	-40	125		
Analog reference voltage	V_{AREF}	4	$V_{DD} + 0.1$	V	–
Analog ground voltage	V_{AGND}	$V_{SS} - 0.1$	$V_{SS} + 0.2$	V	–
Analog input voltage	V_{AIN}	$V_{AGND} - 0.2$	$V_{AREF} + 0.2$	V	–
XTAL clock	f_{OSC}	2	20 (with 50% duty cycle)	MHz	¹⁾

1) For the extended temperature range -40 °C to 110 °C (SAH) and -40 °C to 125 °C (SAK), the devices C505-2R, C505-L, C505C-2R and C505C-L have the max. operating frequency of 16MHz with 50% clock duty cycle.

Parameter Interpretation

The parameters listed in the following partly represent the characteristics of the C505 and partly its demands on the system. To aid in interpreting the parameters right, when evaluating them for a design, they are marked in column “Symbol”:

CC (Controller Characteristics):

The logic of the C505 will provide signals with the respective characteristics.

SR (System Requirement):

The external system must provide signals with the respective characteristics to the C505.

DC Characteristics

(Operating Conditions apply)

Parameter	Symbol	Limit Values		Unit	Test Condition
		min.	max.		
Input low voltages all except \overline{EA} , RESET	V_{IL}	- 0.5	$0.2 V_{DD} - 0.1$	V	-
\overline{EA} pin	V_{IL1}	- 0.5	$0.2 V_{DD} - 0.3$	V	-
RESET pin	V_{IL2}	- 0.5	$0.2 V_{DD} + 0.1$	V	-
Input high voltages all except XTAL1, RESET	V_{IH}	$0.2 V_{DD} + 0.9$	$V_{DD} + 0.5$	V	-
XTAL1 pin	V_{IH1}	$0.7 V_{DD}$	$V_{DD} + 0.5$	V	-
RESET pin	V_{IH2}	$0.6 V_{DD}$	$V_{DD} + 0.5$	V	-
Output low voltages Ports 1, 2, 3, 4	V_{OL}	-	0.45	V	$I_{OL} = 1.6 \text{ mA}^1$
Port 0, ALE, PSEN	V_{OL1}	-	0.45	V	$I_{OL} = 3.2 \text{ mA}^1$
Output high voltages Ports 1, 2, 3, 4	V_{OH}	2.4 $0.9 V_{DD}$	-	V V	$I_{OH} = - 80 \mu\text{A}$ $I_{OH} = - 10 \mu\text{A}$
Port 0 in external bus mode, ALE, PSEN	V_{OH2}	2.4 $0.9 V_{DD}$	-	V V	$I_{OH} = - 800 \mu\text{A}$ $I_{OH} = - 80 \mu\text{A}^2$
Logic 0 input current Ports 1, 2, 3, 4	I_{IL}	- 10	- 70	μA	$V_{IN} = 0.45 \text{ V}$
Logical 1-to-0 transition current Ports 1, 2, 3, 4	I_{TL}	- 65	- 650	μA	$V_{IN} = 2 \text{ V}$
Input leakage current Port 0, AN0-7 (Port 1), \overline{EA}	I_{LI}	-	± 1	μA	$0.45 < V_{IN} < V_{DD}$
Input high current to RESET	I_{IH}	5	100	μA	¹⁴⁾ $0.6 V_{DD} < V_{IN} < V_{DD}$
Pin capacitance	C_{IO}	-	10	pF	$f_c = 1 \text{ MHz}$, $T_A = 25 \text{ }^\circ\text{C}$
Overload current	I_{OV}	-	± 5	mA	^{3) 4)}
Programming voltage	V_{PP}	10.9	12.1	V	$11.5 \text{ V} \pm 5\%^5$
Supply current at \overline{EA}/V_{PP}			30	mA	⁶⁾

 Notes see [Page 60](#)

Power Supply Currents

Parameter			Symbol	Limit Values		Unit	Test Condition
				typ. ¹²⁾	max. ¹³⁾		
C505 / C505C	Active Mode	12 MHz	I_{DD}	19.3	27.0	mA	7)
		20 MHz	I_{DD}	31.3	39		
	Idle Mode	12 MHz	I_{DD}	10.3	13.0	mA	8)
		20 MHz	I_{DD}	16.2	21.0		
	Active Mode with slow-down enabled	12 MHz	I_{DD}	3.9	5.5	mA	9)
20 MHz		I_{DD}	4.8	7.5			
Idle Mode with slow-down enabled	12 MHz	I_{DD}	3.2	5.0	mA	10)	
	20 MHz	I_{DD}	4.0	7.0			
Power down mode			I_{PD}	10	50	μ A	$V_{DD} = 2..5.5 V$ ¹¹⁾
C505A-4E /C505CA-4E	Active Mode	16 MHz	I_{DD}	28.7	30.7	mA	7)
		20 MHz	I_{DD}	35.2	37.6		
	Idle Mode	16 MHz	I_{DD}	14.9	15.9	mA	8)
		20 MHz	I_{DD}	17.7	18.9		
	Active Mode with slow-down enabled	16 MHz	I_{DD}	9.9	12.8	mA	9)
20 MHz		I_{DD}	12.3	15.6			
Idle Mode with slow-down enabled	16 MHz	I_{DD}	5.1	5.6	mA	10)	
	20 MHz	I_{DD}	6.3	6.8			
Power down mode			I_{PD}	5.6	20	μ A	$V_{DD} = 2..5.5 V$ ¹¹⁾
C505A-4R / C505CA-4R /C505A-2R / C505CA-2R /C505A-L / C505CA-L	Active Mode	16 MHz	I_{DD}	22.8	29.2	mA	7)
		20 MHz	I_{DD}	27.6	35.3		
	Idle Mode	16 MHz	I_{DD}	12.7	16.3	mA	8)
		20 MHz	I_{DD}	15.0	19.3		
	Active Mode with slow-down enabled	16 MHz	I_{DD}	6.6	8.2	mA	9)
20 MHz		I_{DD}	7.3	9.3			
Idle Mode with slow-down enabled	16 MHz	I_{DD}	5.0	5.9	mA	10)	
	20 MHz	I_{DD}	5.3	6.5			
Power down mode			I_{PD}	5.3	30	μ A	$V_{DD} = 2..5.5 V$ ¹¹⁾

 Notes see [Page 60](#)

Note:

- 1) Capacitive loading on ports 0 and 2 may cause spurious noise pulses to be superimposed on the V_{OL} of ALE and port 3. The noise is due to external bus capacitance discharging into the port 0 and port 2 pins when these pins make 1-to-0 transitions during bus operation. In the worst case (capacitive loading > 100 pF), the noise pulse on ALE line may exceed 0.8 V. In such cases it may be desirable to qualify ALE with a schmitt-trigger, or use an address latch with a schmitt-trigger strobe input.
- 2) Capacitive loading on ports 0 and 2 may cause the V_{OH} on ALE and \overline{PSEN} to momentarily fall below the $0.9 V_{DD}$ specification when the address lines are stabilizing.
- 3) Overload conditions under operating conditions occur if the voltage on the respective pin exceeds the specified operating range (i.e. $V_{OV} > V_{DD} + 0.5 \text{ V}$ or $V_{OV} < V_{SS} - 0.5 \text{ V}$). The absolute sum of input currents on all port pins may not exceed 50 mA. The supply voltage V_{DD} and V_{SS} must remain within the specified limits.
- 4) Not 100% tested, guaranteed by design characterization.
- 5) Only valid for C505A-4E and C505CA-4E.
- 6) Only valid for C505A-4E and C505CA-4E in programming mode.
- 7) I_{DD} (active mode) is measured with:
XTAL1 driven with $t_R, t_F = 5 \text{ ns}$, 50% duty cycle, $V_{IL} = V_{SS} + 0.5 \text{ V}$, $V_{IH} = V_{DD} - 0.5 \text{ V}$; XTAL2 = N.C.;
 $\overline{EA} = \text{Port 0} = \text{RESET} = V_{DD}$; all other pins are disconnected.
- 8) I_{DD} (idle mode) is measured with all output pins disconnected and with all peripherals disabled;
XTAL1 driven with $t_R, t_F = 5 \text{ ns}$, 50% duty cycle, $V_{IL} = V_{SS} + 0.5 \text{ V}$, $V_{IH} = V_{DD} - 0.5 \text{ V}$; XTAL2 = N.C.;
 $\text{RESET} = \overline{EA} = V_{SS}$; $\text{Port0} = V_{DD}$; all other pins are disconnected; the microcontroller is put into idle mode by software;
- 9) I_{DD} (active mode with slow-down mode) is measured with all output pins disconnected and with all peripherals disabled;
XTAL1 driven with $t_R, t_F = 5 \text{ ns}$, 50% duty cycle, $V_{IL} = V_{SS} + 0.5 \text{ V}$, $V_{IH} = V_{DD} - 0.5 \text{ V}$; XTAL2 = N.C.;
 $\text{RESET} = \overline{EA} = V_{SS}$; all other pins are disconnected; the microcontroller is put into slow-down mode by software;
- 10) I_{DD} (idle mode with slow-down mode) is measured with all output pins disconnected and with all peripherals disabled;
XTAL1 driven with $t_R, t_F = 5 \text{ ns}$, 50% duty cycle, $V_{IL} = V_{SS} + 0.5 \text{ V}$, $V_{IH} = V_{DD} - 0.5 \text{ V}$; XTAL2 = N.C.;
 $\text{RESET} = \overline{EA} = V_{SS}$; $\text{Port0} = V_{DD}$; all other pins are disconnected; the microcontroller is put into idle mode with slow-down enabled by software;
- 11) I_{PD} (power-down mode) is measured under following conditions:
 $\text{Port 0} = \overline{EA} = V_{DD}$; $\text{RESET} = V_{SS}$; XTAL2 = N.C.; XTAL1 = V_{SS} ; $V_{AGND} = V_{SS}$; $V_{AREF} = V_{DD}$;
all other pins are disconnected.
- 12) The typical I_{DD} values are periodically measured at $T_A = +25 \text{ }^\circ\text{C}$ but not 100% tested.
- 13) The maximum I_{DD} values are measured under worst case conditions ($T_A = 0 \text{ }^\circ\text{C}$ or $-40 \text{ }^\circ\text{C}$ and $V_{DD} = 5.5 \text{ V}$)
- 14) The values are valid for C505CA-4R, C505CA-2R, C505CA-L, C505A-4R, C505A-2R and C505A-L only.

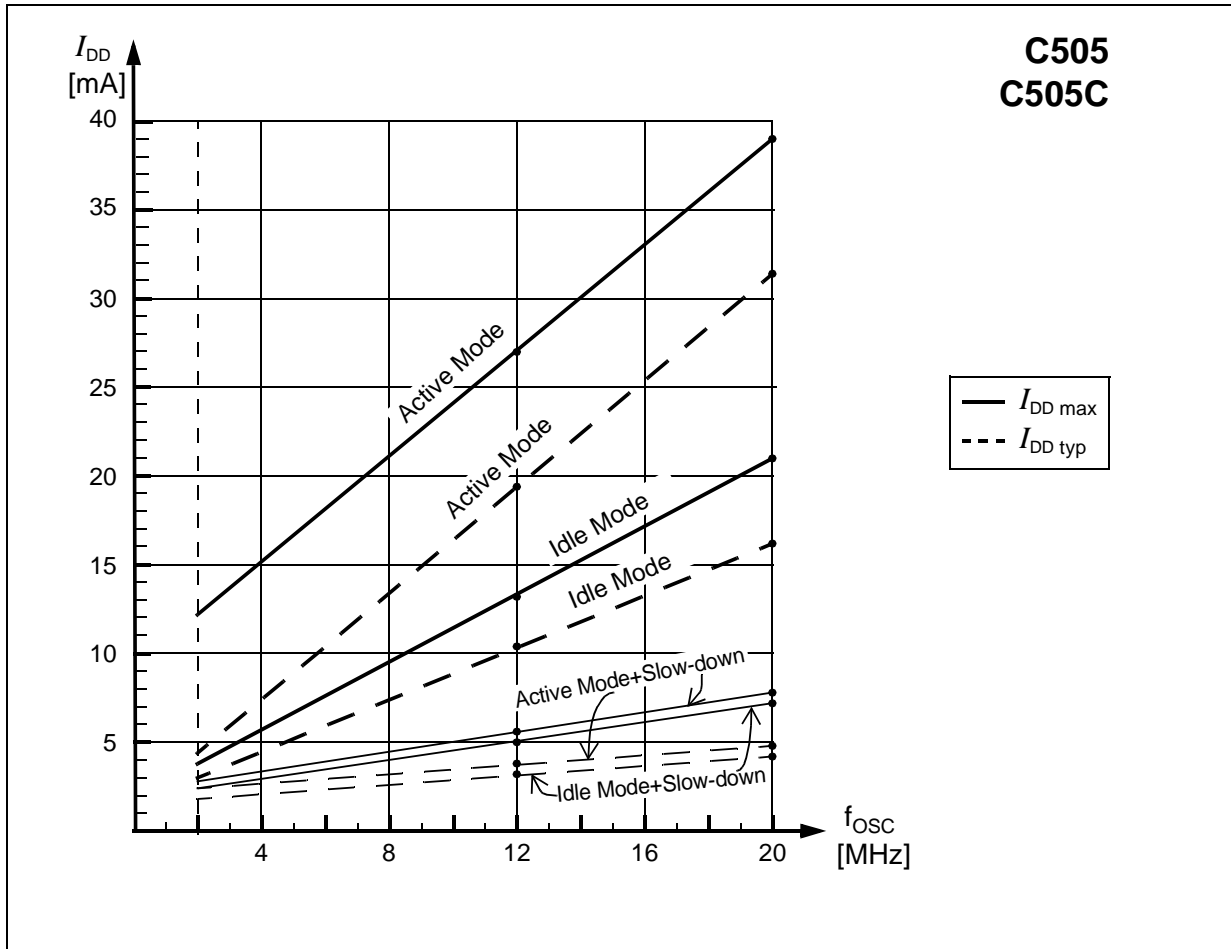

Figure 29
IDD Diagram of C505 and C505C

C505/C505C : Power Supply Current Calculation Formulas

Parameter	Symbol	Formula
Active mode	$I_{DD\ typ}$	$1.5 * f_{OSC} + 1.3$
	$I_{DD\ max}$	$1.5 * f_{OSC} + 9.0$
Idle mode	$I_{DD\ typ}$	$0.74 * f_{OSC} + 1.4$
	$I_{DD\ max}$	$1.0 * f_{OSC} + 1.0$
Active mode with slow-down enabled	$I_{DD\ typ}$	$0.11 * f_{OSC} + 2.6$
	$I_{DD\ max}$	$0.25 * f_{OSC} + 2.5$
Idle mode with slow-down enabled	$I_{DD\ typ}$	$0.1 * f_{OSC} + 2.0$
	$I_{DD\ max}$	$0.25 * f_{OSC} + 2.0$

Note: f_{OSC} is the oscillator frequency in MHz. I_{DD} values are given in mA.

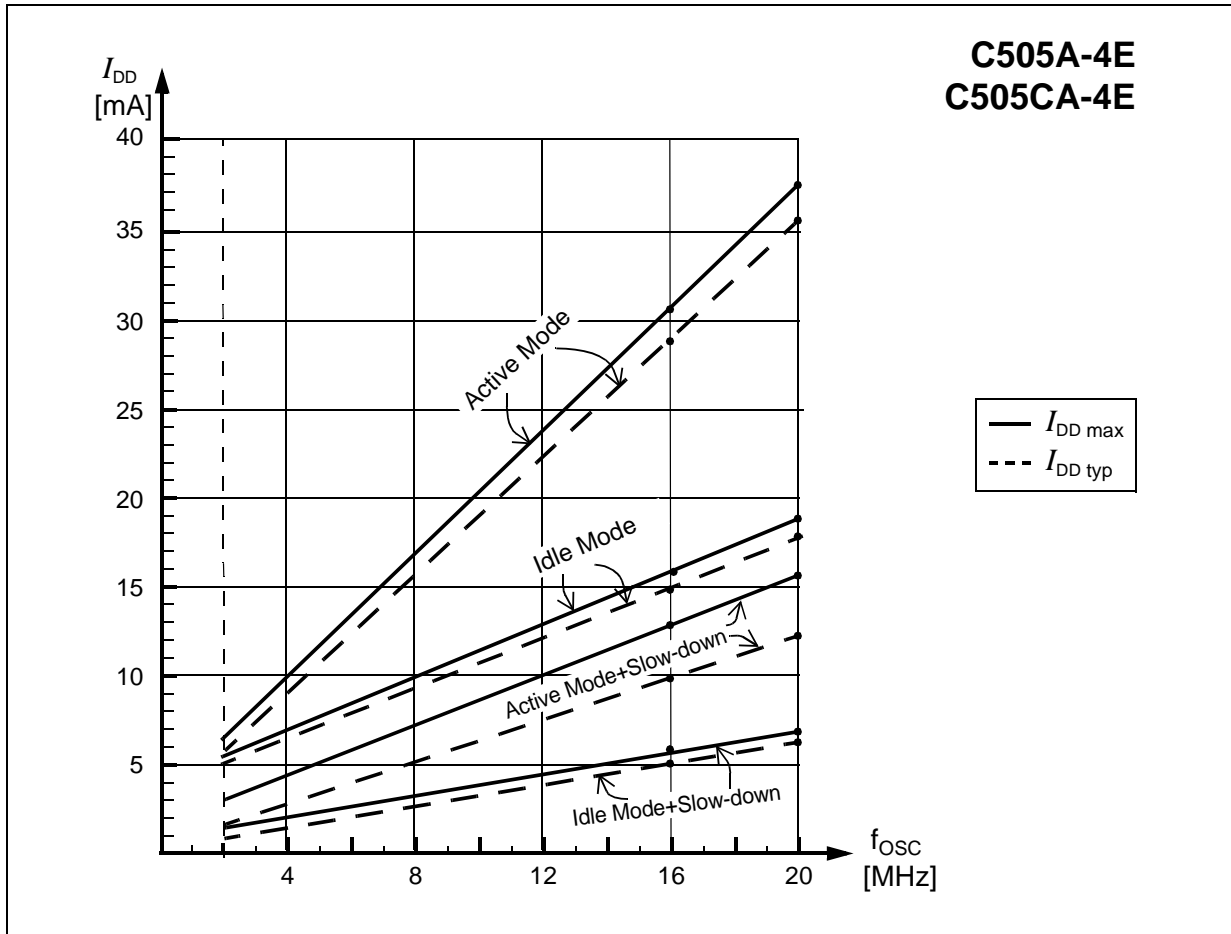

Figure 30
IDD Diagram of C505A-4E and C505CA-4E

C505A-4E/C505CA-4E : Power Supply Current Calculation Formulas

Parameter	Symbol	Formula
Active mode	$I_{DD\ typ}$	$1.63 * f_{OSC} + 2.6$
	$I_{DD\ max}$	$1.74 * f_{OSC} + 2.8$
Idle mode	$I_{DD\ typ}$	$0.69 * f_{OSC} + 3.9$
	$I_{DD\ max}$	$0.74 * f_{OSC} + 4.1$
Active mode with slow-down enabled	$I_{DD\ typ}$	$0.6 * f_{OSC} + 0.3$
	$I_{DD\ max}$	$0.7 * f_{OSC} + 1.6$
Idle mode with slow-down enabled	$I_{DD\ typ}$	$0.3 * f_{OSC} + 0.3$
	$I_{DD\ max}$	$0.3 * f_{OSC} + 0.8$

Note: f_{OSC} is the oscillator frequency in MHz. I_{DD} values are given in mA.

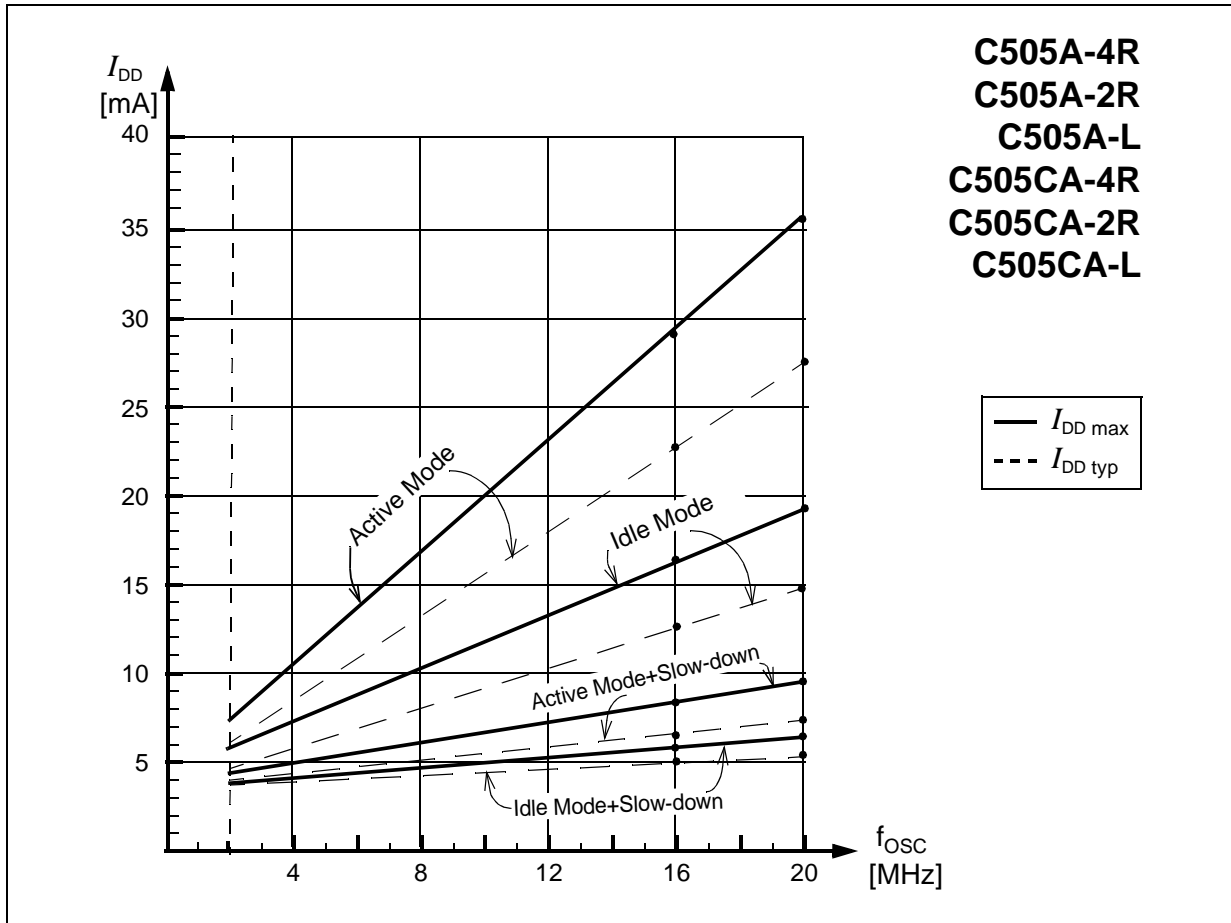

Figure 31
 I_{DD} Diagram of C505A-4R/C505A-2R/C505A-L/C505CA-4R/C505CA-2R/C505CA-L

C505A-4R/C505A-2R/C505A-L/C505CA-4R/C505CA-2R/C505CA-L :
Power Supply Current Calculation Formulas

Parameter	Symbol	Formula
Active mode	$I_{DD\ typ}$	$1.19 * f_{OSC} + 3.77$
	$I_{DD\ max}$	$1.54 * f_{OSC} + 4.47$
Idle mode	$I_{DD\ typ}$	$0.57 * f_{OSC} + 3.55$
	$I_{DD\ max}$	$0.75 * f_{OSC} + 4.26$
Active mode with slow-down enabled	$I_{DD\ typ}$	$0.18 * f_{OSC} + 3.74$
	$I_{DD\ max}$	$0.28 * f_{OSC} + 3.67$
Idle mode with slow-down enabled	$I_{DD\ typ}$	$0.07 * f_{OSC} + 3.91$
	$I_{DD\ max}$	$0.14 * f_{OSC} + 3.64$

Note: f_{OSC} is the oscillator frequency in MHz. I_{DD} values are given in mA.

A/D Converter Characteristics of C505 and C505C

(Operating Conditions apply)

Parameter	Symbol	Limit Values		Unit	Test Condition
		min.	max.		
Analog input voltage	V_{AIN}	$V_{AGND} - 0.2$	$V_{AREF} + 0.2$	V	¹⁾
Sample time	t_S	–	$64 \times t_{IN}$ $32 \times t_{IN}$ $16 \times t_{IN}$ $8 \times t_{IN}$	ns	Prescaler ÷ 32 Prescaler ÷ 16 Prescaler ÷ 8 Prescaler ÷ 4 ²⁾
Conversion cycle time	t_{ADCC}	–	$320 \times t_{IN}$ $160 \times t_{IN}$ $80 \times t_{IN}$ $40 \times t_{IN}$	ns	Prescaler ÷ 32 Prescaler ÷ 16 Prescaler ÷ 8 Prescaler ÷ 4 ³⁾
Total unadjusted error	T_{UE}	–	± 2	LSB	$V_{SS} + 0.5V \leq V_{AIN} \leq V_{DD} - 0.5V$ ⁴⁾
Internal resistance of reference voltage source	R_{AREF}	–	$t_{ADC} / 500 - 1$	kΩ	t_{ADC} in [ns] ^{5) 6)}
Internal resistance of analog source	R_{ASRC}	–	$t_S / 500 - 1$	kΩ	t_S in [ns] ^{2) 6)}
ADC input capacitance	C_{AIN}	–	50	pF	⁶⁾

Notes see next page.

Clock calculation table :

Clock Prescaler Ratio	ADCL1, 0	t_{ADC}	t_S	t_{ADCC}
÷ 32	1 1	$32 \times t_{IN}$	$64 \times t_{IN}$	$320 \times t_{IN}$
÷ 16	1 0	$16 \times t_{IN}$	$32 \times t_{IN}$	$160 \times t_{IN}$
÷ 8	0 1	$8 \times t_{IN}$	$16 \times t_{IN}$	$80 \times t_{IN}$
÷ 4	0 0	$4 \times t_{IN}$	$8 \times t_{IN}$	$40 \times t_{IN}$

 Further timing conditions : $t_{ADC} \text{ min} = 800 \text{ ns}$
 $t_{IN} = 1 / f_{OSC} = t_{CLP}$

Note:

- 1) V_{AIN} may exceed V_{AGND} or V_{AREF} up to the absolute maximum ratings. However, the conversion result in these cases will be 00_H or FF_H , respectively.
- 2) During the sample time the input capacitance C_{AIN} must be charged/discharged by the external source. The internal resistance of the analog source must allow the capacitance to reach their final voltage level within t_S . After the end of the sample time t_S , changes of the analog input voltage have no effect on the conversion result.
- 3) This parameter includes the sample time t_S , the time for determining the digital result. Values for the conversion clock t_{ADC} depend on programming and can be taken from the table on the previous page.
- 4) T_{UE} (max.) is tested at $-40 \leq T_A \leq 125 \text{ }^\circ\text{C}$; $V_{DD} \leq 5.5 \text{ V}$; $V_{AREF} \leq V_{DD} + 0.1 \text{ V}$ and $V_{SS} \leq V_{AGND}$. It is guaranteed by design characterization for all other voltages within the defined voltage range.
If an overload condition occurs on maximum 2 unused analog input pins and the absolute sum of input overload currents on all analog input pins does not exceed 10 mA, an additional conversion error of 1/2 LSB is permissible.
- 5) During the conversion the ADC's capacitance must be repeatedly charged or discharged. The internal resistance of the reference source must allow the capacitance to reach their final voltage level within the indicated time. The maximum internal resistance results from the programmed conversion timing.
- 6) Not 100% tested, but guaranteed by design characterization.

A/D Converter Characteristics of C505A and C505CA

(Operating Conditions apply)

Parameter	Symbol	Limit Values		Unit	Test Condition
		min.	max.		
Analog input voltage	V_{AIN}	V_{AGND}	V_{AREF}	V	¹⁾
Sample time	t_S	–	$64 \times t_{IN}$ $32 \times t_{IN}$ $16 \times t_{IN}$ $8 \times t_{IN}$	ns	Prescaler ÷ 32 Prescaler ÷ 16 Prescaler ÷ 8 Prescaler ÷ 4 ²⁾
Conversion cycle time	t_{ADCC}	–	$384 \times t_{IN}$ $192 \times t_{IN}$ $96 \times t_{IN}$ $48 \times t_{IN}$	ns	Prescaler ÷ 32 Prescaler ÷ 16 Prescaler ÷ 8 Prescaler ÷ 4 ³⁾
Total unadjusted error	T_{UE}	–	± 2	LSB	$V_{SS}+0.5V \leq V_{AIN} \leq V_{DD}-0.5V$ ⁴⁾
		–	± 4	LSB	$V_{SS} < V_{AIN} < V_{DD}+0.5V$ $V_{DD} - 0.5 V < V_{AIN} < V_{DD}$ ⁴⁾
Internal resistance of reference voltage source	R_{AREF}	–	$t_{ADC} / 250$ – 0.25	kΩ	t_{ADC} in [ns] ^{5) 6)}
Internal resistance of analog source	R_{ASRC}	–	$t_S / 500$ – 0.25	kΩ	t_S in [ns] ^{2) 6)}
ADC input capacitance	C_{AIN}	–	50	pF	⁶⁾

Notes see next page.

Clock calculation table :

Clock Prescaler Ratio	ADCL1, 0		t_{ADC}	t_S	t_{ADCC}
÷ 32	1	1	$32 \times t_{IN}$	$64 \times t_{IN}$	$384 \times t_{IN}$
÷ 16	1	0	$16 \times t_{IN}$	$32 \times t_{IN}$	$192 \times t_{IN}$
÷ 8	0	1	$8 \times t_{IN}$	$16 \times t_{IN}$	$96 \times t_{IN}$
÷ 4	0	0	$4 \times t_{IN}$	$8 \times t_{IN}$	$48 \times t_{IN}$

 Further timing conditions : $t_{ADC} \text{ min} = 500 \text{ ns}$
 $t_{IN} = 1 / f_{OSC} = t_{CLP}$

Note:

- 1) V_{AIN} may exceed V_{AGND} or V_{AREF} up to the absolute maximum ratings. However, the conversion result in these cases will be $X000_H$ or $X3FF_H$, respectively.
- 2) During the sample time the input capacitance C_{AIN} must be charged/discharged by the external source. The internal resistance of the analog source must allow the capacitance to reach their final voltage level within t_S . After the end of the sample time t_S , changes of the analog input voltage have no effect on the conversion result.
- 3) This parameter includes the sample time t_S , the time for determining the digital result and the time for the calibration. Values for the conversion clock t_{ADC} depend on programming and can be taken from the table on the previous page.
- 4) T_{UE} is tested at $V_{AREF} = 5.0\text{ V}$, $V_{AGND} = 0\text{ V}$, $V_{DD} = 4.9\text{ V}$. It is guaranteed by design characterization for all other voltages within the defined voltage range.
If an overload condition occurs on maximum 2 unused analog input pins and the absolute sum of input overload currents on all analog input pins does not exceed 10 mA, an additional conversion error of 1/2 LSB is permissible.
- 5) During the conversion the ADC's capacitance must be repeatedly charged or discharged. The internal resistance of the reference source must allow the capacitance to reach their final voltage level within the indicated time. The maximum internal resistance results from the programmed conversion timing.
- 6) Not 100% tested, but guaranteed by design characterization.

AC Characteristics (16 MHz, 0.4 to 0.6 Duty Cycle)

(Operating Conditions apply)

 (C_L for port 0, ALE and $\overline{\text{PSEN}}$ outputs = 100 pF; C_L for all other outputs = 80 pF)

Program Memory Characteristics

Parameter	Symbol	Limit Values				Unit
		16-MHz clock Duty Cycle 0.4 to 0.6		Variable Clock 1/CLP= 2 MHz to 16 MHz		
		min.	max.	min.	max.	
ALE pulse width	t_{LHLL}	48	–	CLP - 15	–	ns
Address setup to ALE	t_{AVLL}	10	–	$TCL_{Hmin} - 15$	–	ns
Address hold after ALE	t_{LLAX}	10	–	$TCL_{Hmin} - 15$	–	ns
ALE to valid instruction in	t_{LLIV}	–	75	–	2 CLP - 50	ns
ALE to $\overline{\text{PSEN}}$	t_{LLPL}	10	–	$TCL_{Lmin} - 15$	–	ns
$\overline{\text{PSEN}}$ pulse width	t_{PLPH}	73	–	CLP+ $TCL_{Hmin} - 15$	–	ns
$\overline{\text{PSEN}}$ to valid instruction in	t_{PLIV}	–	38	–	CLP+ $TCL_{Hmin} - 50$	ns
Input instruction hold after $\overline{\text{PSEN}}$	t_{PXIX}	0	–	0	–	ns
Input instruction float after $\overline{\text{PSEN}}$	$t_{PXIZ}^*)$	–	15	–	$TCL_{Lmin} - 10$	ns
Address valid after $\overline{\text{PSEN}}$	$t_{PXAV}^*)$	20	–	$TCL_{Lmin} - 5$	–	ns
Address to valid instruction in	t_{AVIV}	–	95	–	2 CLP + $TCL_{Hmin} - 55$	ns
Address float to $\overline{\text{PSEN}}$	t_{AZPL}	-5	–	-5	–	ns

^{*)} Interfacing the C505 to devices with float times up to 20 ns is permissible. This limited bus contention will not cause any damage to port 0 drivers.

AC Characteristics (16 MHz, 0.4 to 0.6 Duty Cycle, cont'd)
External Data Memory Characteristics

Parameter	Symbol	Limit Values				Unit
		16-MHz clock Duty Cycle 0.4 to 0.6		Variable Clock 1/CLP= 2 MHz to 16 MHz		
		min.	max.	min.	max.	
$\overline{\text{RD}}$ pulse width	t_{RLRH}	158	–	3 CLP - 30	–	ns
$\overline{\text{WR}}$ pulse width	t_{WLWH}	158	–	3 CLP - 30	–	ns
Address hold after ALE	t_{LLAX2}	48	–	CLP - 15	–	ns
$\overline{\text{RD}}$ to valid data in	t_{RLDV}	–	100	–	2 CLP+ $\text{TCL}_{\text{Hmin}} - 50$	ns
Data hold after $\overline{\text{RD}}$	t_{RHDX}	0	–	0	–	ns
Data float after $\overline{\text{RD}}$	t_{RHDZ}	–	51	–	CLP - 12	ns
ALE to valid data in	t_{LLDV}	–	200	–	4 CLP - 50	ns
Address to valid data in	t_{AVDV}	–	200	–	4 CLP + $\text{TCL}_{\text{Hmin}} - 75$	ns
ALE to $\overline{\text{WR}}$ or $\overline{\text{RD}}$	t_{LLWL}	73	103	CLP + $\text{TCL}_{\text{Lmin}} - 15$	CLP+ $\text{TCL}_{\text{Lmin}} + 15$	ns
Address valid to $\overline{\text{WR}}$	t_{AVWL}	95	–	2 CLP - 30	–	ns
$\overline{\text{WR}}$ or $\overline{\text{RD}}$ high to ALE high	t_{WHLH}	10	40	$\text{TCL}_{\text{Hmin}} - 15$	$\text{TCL}_{\text{Hmin}} + 15$	ns
Data valid to $\overline{\text{WR}}$ transition	t_{QVWX}	5	–	$\text{TCL}_{\text{Lmin}} - 20$	–	ns
Data setup before $\overline{\text{WR}}$	t_{QVWH}	163	–	3 CLP + $\text{TCL}_{\text{Lmin}} - 50$	–	ns
Data hold after $\overline{\text{WR}}$	t_{WHQX}	5	–	$\text{TCL}_{\text{Hmin}} - 20$	–	ns
Address float after $\overline{\text{RD}}$	t_{RLAZ}	–	0	–	0	ns

AC Characteristics (16 MHz, 0.4 to 0.6 Duty Cycle, cont'd)
External Clock Drive Characteristics

Parameter	Symbol	CPU Clock = 16 MHz Duty Cycle 0.4 to 0.6		Variable CPU Clock 1/CLP = 2 to 16 MHz		Unit
		min.	max.	min.	max.	
Oscillator period	CLP	62.5	62.5	62.5	500	ns
High time	TCL _H	25	–	25	CLP - TCL _L	ns
Low time	TCL _L	25	–	25	CLP - TCL _H	ns
Rise time	t _R	–	10	–	10	ns
Fall time	t _F	–	10	–	10	ns
Oscillator duty cycle	DC	0.4	0.6	25 / CLP	1 - 25 / CLP	–
Clock cycle	TCL	25	37.5	CLP * DC _{min}	CLP * DC _{max}	ns

Note: The 16 MHz values in the tables are given as an example for a typical duty cycle variation of the oscillator clock from 0.4 to 0.6.

AC Characteristics (20 MHz, 0.5 Duty Cycle)

(Operating Conditions apply)

 (C_L for port 0, ALE and $\overline{\text{PSEN}}$ outputs = 100 pF; C_L for all other outputs = 80 pF)

Program Memory Characteristics

Parameter	Symbol	Limit Values				Unit
		20 MHz clock 0.5 Duty Cycle		Variable Clock 1/CLP = 2 MHz to 20 MHz		
		min.	max.	min.	max.	
ALE pulse width	t_{LHLL}	35	–	CLP - 15	–	ns
Address setup to ALE	t_{AVLL}	10	–	CLP/2 - 15	–	ns
Address hold after ALE	t_{LLAX}	10	–	CLP/2 - 15	–	ns
ALE to valid instruction in	t_{LLIV}	–	55	–	2 CLP - 45	ns
ALE to $\overline{\text{PSEN}}$	t_{LLPL}	10	–	CLP/2 - 15	–	ns
$\overline{\text{PSEN}}$ pulse width	t_{PLPH}	60	–	3/2 CLP - 15	–	ns
$\overline{\text{PSEN}}$ to valid instruction in	t_{PLIV}	–	25	–	3/2 CLP - 50	ns
Input instruction hold after $\overline{\text{PSEN}}$	t_{PXIX}	0	–	0	–	ns
Input instruction float after $\overline{\text{PSEN}}$	$t_{PXIZ}^{*)}$	–	20	–	CLP/2 - 5	ns
Address valid after $\overline{\text{PSEN}}$	$t_{PXAV}^{*)}$	20	–	CLP/2 - 5	–	ns
Address to valid instruction in	t_{AVIV}	–	65	–	5/2 CLP - 60	ns
Address float to $\overline{\text{PSEN}}$	t_{AZPL}	- 5	–	- 5	–	ns

^{*)} Interfacing the C505 to devices with float times up to 20 ns is permissible. This limited bus contention will not cause any damage to port 0 drivers.

AC Characteristics (20 MHz, 0.5 Duty Cycle, cont'd)
External Data Memory Characteristics

Parameter	Symbol	Limit Values				Unit
		20 MHz clock 0.5 Duty Cycle		Variable Clock 1/CLP = 2 MHz to 20 MHz		
		min.	max.	min.	max.	
\overline{RD} pulse width	t_{RLRH}	120	–	3 CLP - 30	–	ns
\overline{WR} pulse width	t_{WLWH}	120	–	3 CLP - 30	–	ns
Address hold after ALE	t_{LLAX2}	35	–	CLP - 15	–	ns
\overline{RD} to valid data in	t_{RLDV}	–	75	–	5/2 CLP - 50	ns
Data hold after \overline{RD}	t_{RHDX}	0	–	0	–	ns
Data float after \overline{RD}	t_{RHDZ}	–	38	–	CLP - 12	ns
ALE to valid data in	t_{LLDV}	–	150	–	4 CLP - 50	ns
Address to valid data in	t_{AVDV}	–	150	–	9/2 CLP - 75	ns
ALE to \overline{WR} or \overline{RD}	t_{LLWL}	60	90	3/2 CLP - 15	3/2 CLP + 15	ns
Address valid to \overline{WR}	t_{AVWL}	70	–	2 CLP - 30	–	ns
\overline{WR} or \overline{RD} high to ALE high	t_{WHLH}	10	40	CLP/2 - 15	CLP/2 + 15	ns
Data valid to \overline{WR} transition	t_{QVWX}	5	–	CLP/2 - 20	–	ns
Data setup before \overline{WR}	t_{QVWH}	125	–	7/2 CLP - 50	–	ns
Data hold after \overline{WR}	t_{WHQX}	5	–	CLP/2 - 20	–	ns
Address float after \overline{RD}	t_{RLAZ}	–	0	–	0	ns

External Clock Drive Characteristics

Parameter	Symbol	Limit Values		Unit
		Variable Clock Freq. = 2 MHz to 20 MHz		
		min.	max.	
Oscillator period	CLP	50	500	ns
High time	TCL_H	15	$CLP - TCL_L$	ns
Low time	TCL_L	15	$CLP - TCL_H$	ns
Rise time	t_R	–	10	ns
Fall time	t_F	–	10	ns
Oscillator duty cycle	DC	0.5	0.5	–

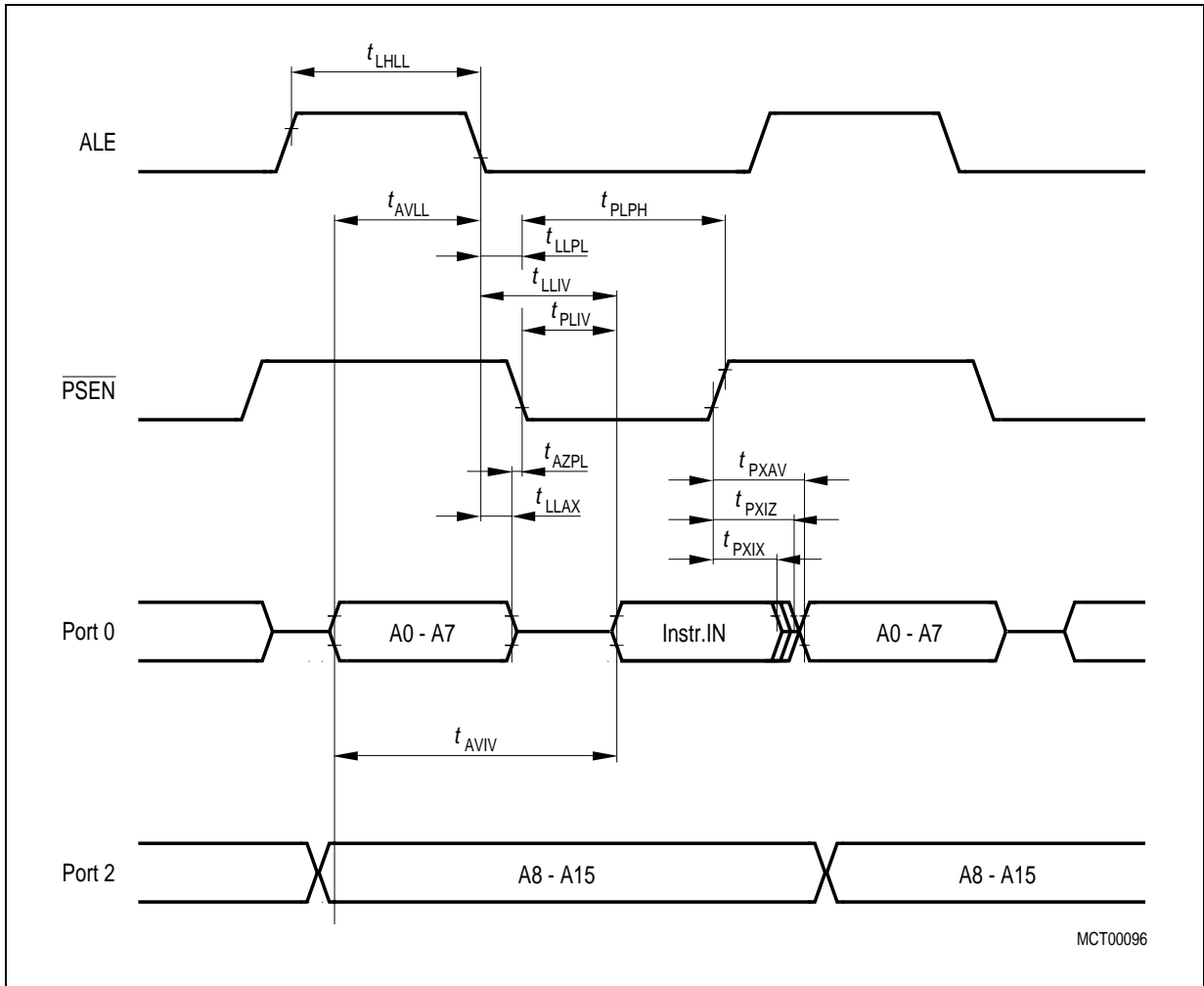
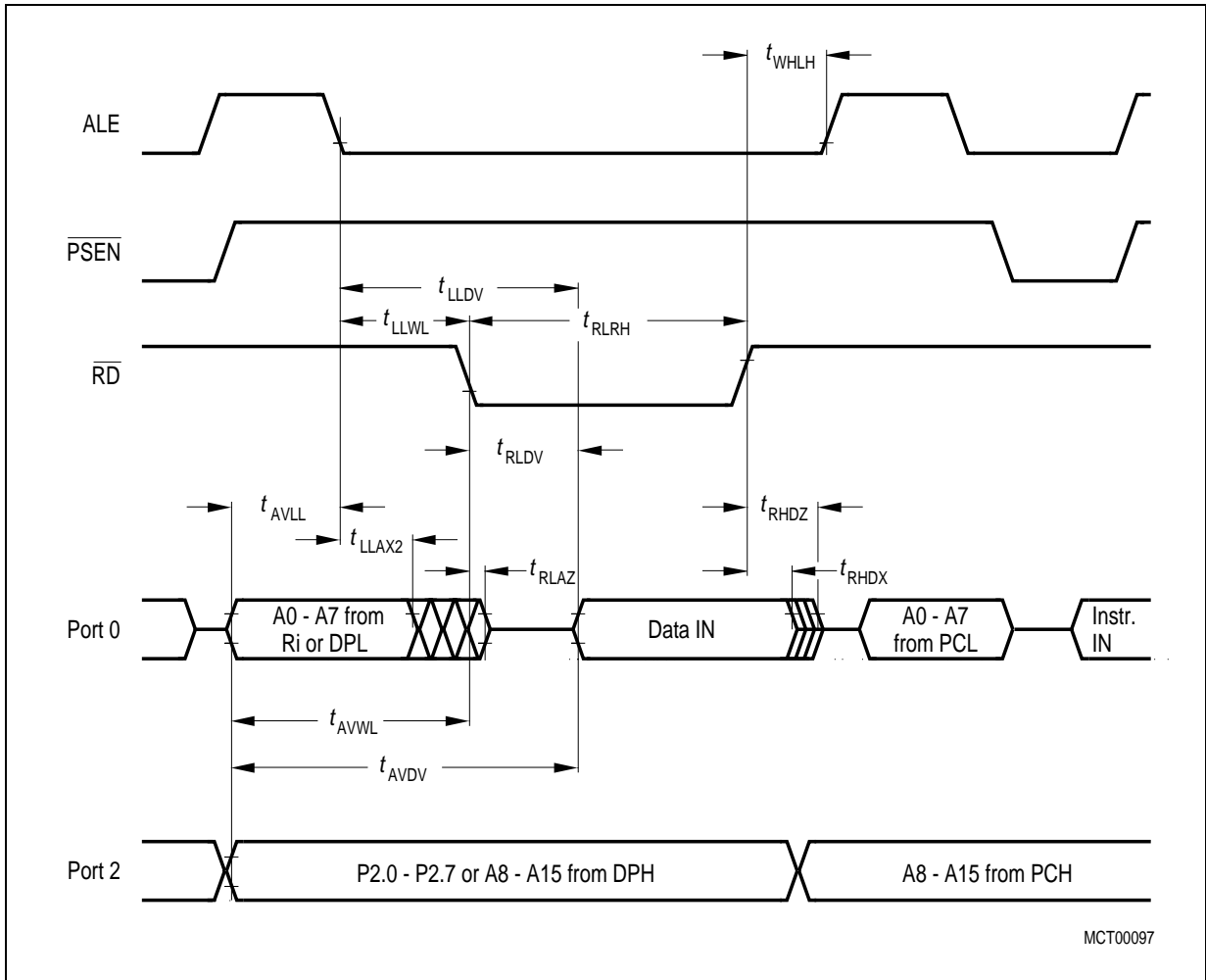

Figure 32
Program Memory Read Cycle



MCT00097

Figure 33
Data Memory Read Cycle

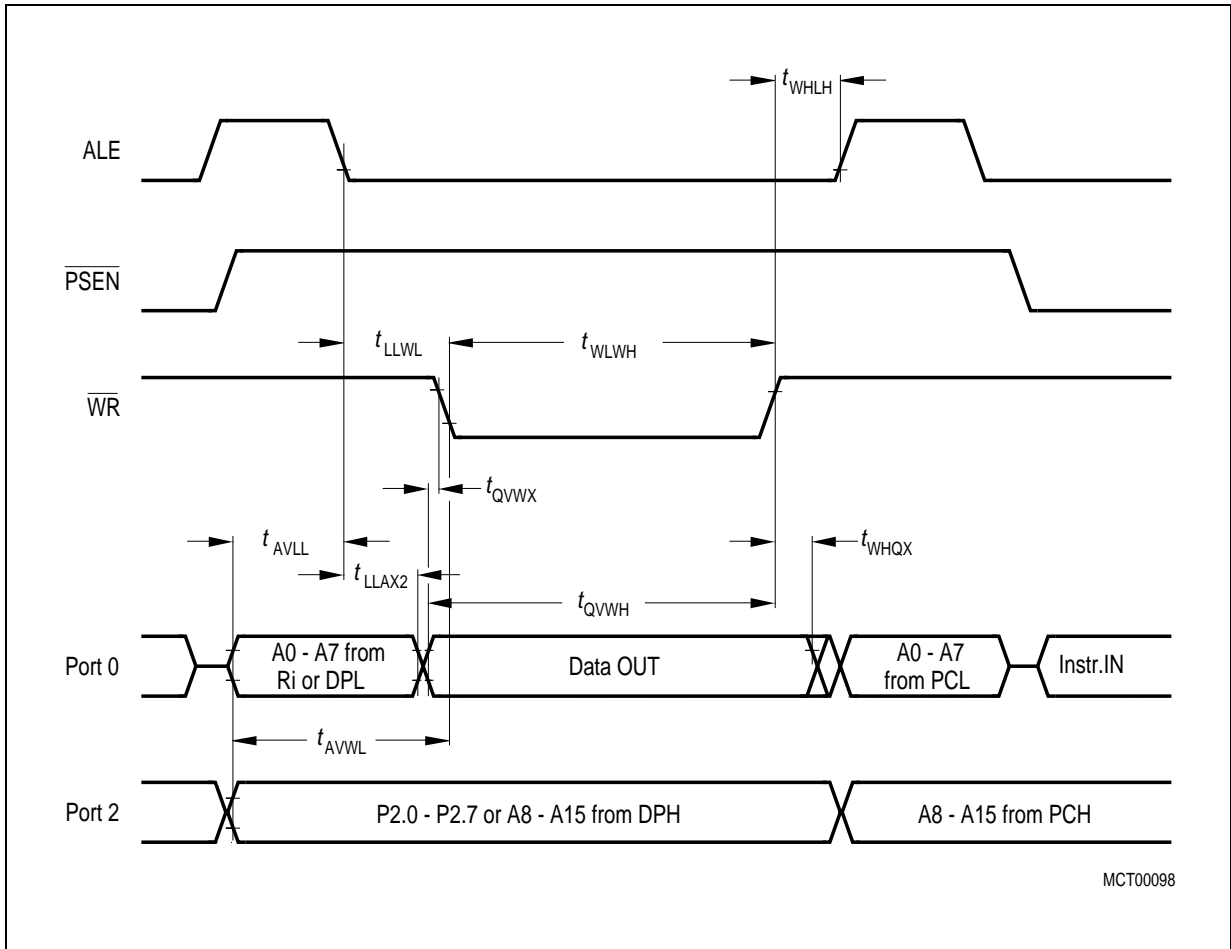

Figure 34
Data Memory Write Cycle

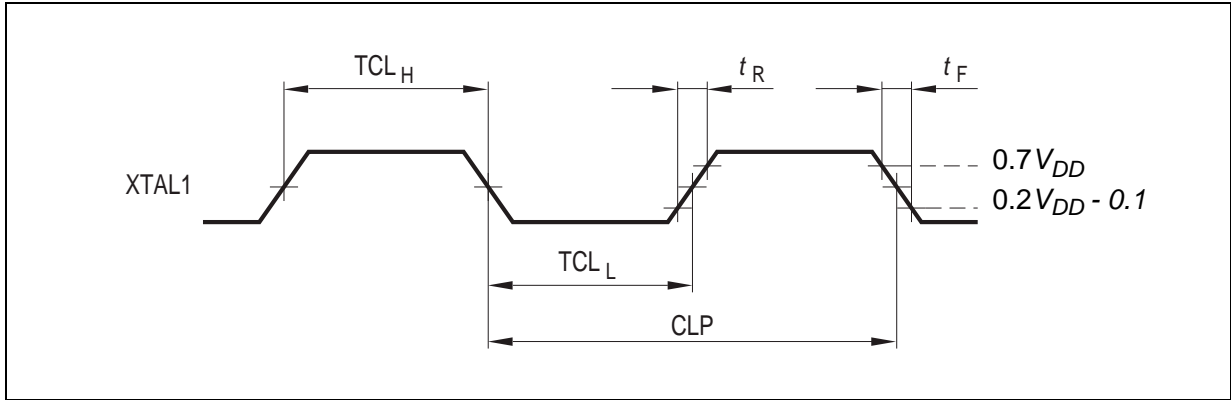

Figure 35
External Clock Drive on XTAL1

AC Characteristics of Programming Mode (C505A-4E and C505CA-4E only)
 $V_{DD} = 5\text{ V} \pm 10\%$; $V_{PP} = 11.5\text{ V} \pm 5\%$; $T_A = 25\text{ }^\circ\text{C} \pm 10\text{ }^\circ\text{C}$

Parameter	Symbol	Limit Values		Unit
		min.	max.	
PALE pulse width	t_{PAW}	35	–	ns
PMSEL setup to PALE rising edge	t_{PMS}	10	–	
Address setup to PALE, $\overline{\text{PROG}}$, or $\overline{\text{PRD}}$ falling edge	t_{PAS}	10	–	ns
Address hold after PALE, $\overline{\text{PROG}}$, or $\overline{\text{PRD}}$ falling edge	t_{PAH}	10	–	ns
Address, data setup to $\overline{\text{PROG}}$ or $\overline{\text{PRD}}$	t_{PCS}	100	–	ns
Address, data hold after $\overline{\text{PROG}}$ or $\overline{\text{PRD}}$	t_{PCH}	0	–	ns
PMSEL setup to $\overline{\text{PROG}}$ or $\overline{\text{PRD}}$	t_{PMS}	10	–	ns
PMSEL hold after $\overline{\text{PROG}}$ or $\overline{\text{PRD}}$	t_{PMH}	10	–	ns
$\overline{\text{PROG}}$ pulse width	t_{PWW}	100	–	μs
$\overline{\text{PRD}}$ pulse width	t_{PRW}	100	–	ns
Address to valid data out	t_{PAD}	–	75	ns
$\overline{\text{PRD}}$ to valid data out	t_{PRD}	–	20	ns
Data hold after $\overline{\text{PRD}}$	t_{PDH}	0	–	ns
Data float after $\overline{\text{PRD}}$	t_{PDF}	–	20	ns
$\overline{\text{PROG}}$ high between two consecutive $\overline{\text{PROG}}$ low pulses	t_{PWH1}	1	–	μs
$\overline{\text{PRD}}$ high between two consecutive $\overline{\text{PRD}}$ low pulses	t_{PWH2}	100		ns
XTAL clock period	t_{CLKP}	83.3	500	ns

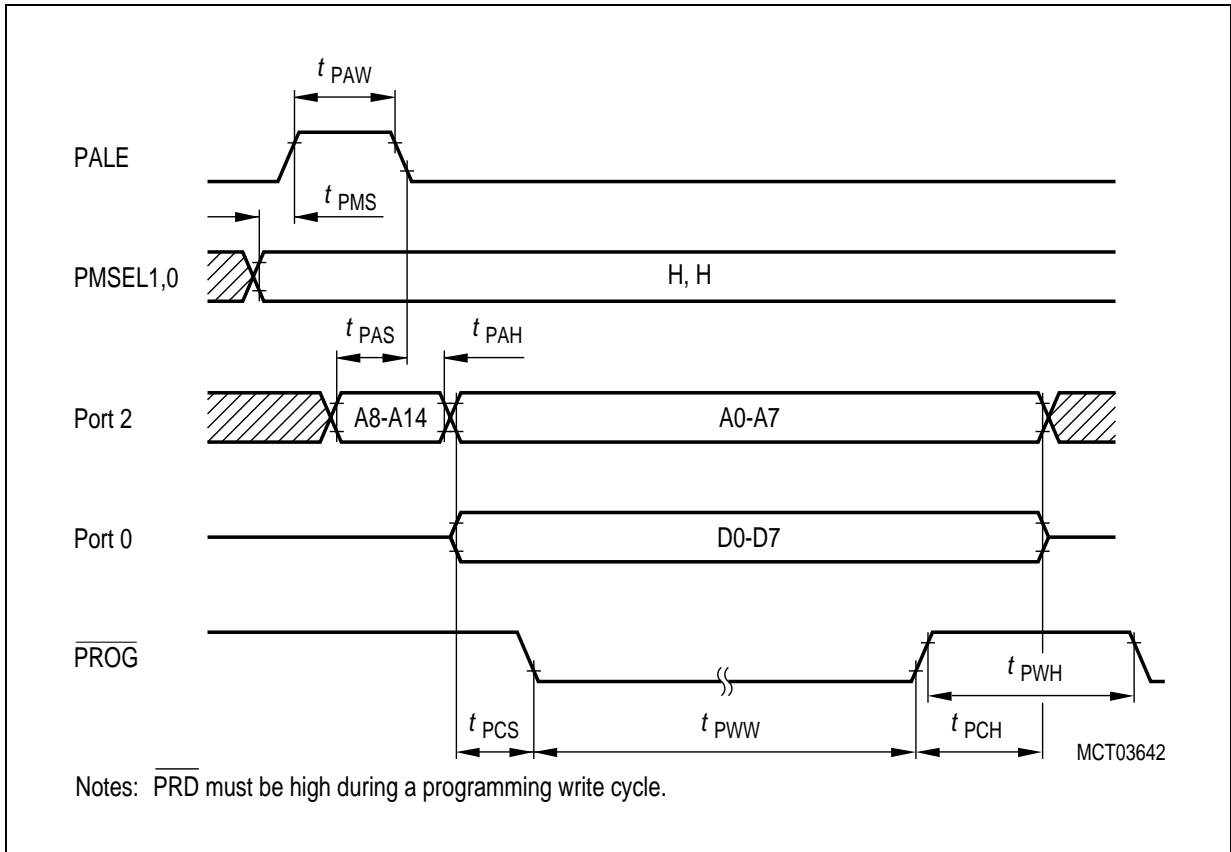

Figure 36
Programming Code Byte - Write Cycle Timing

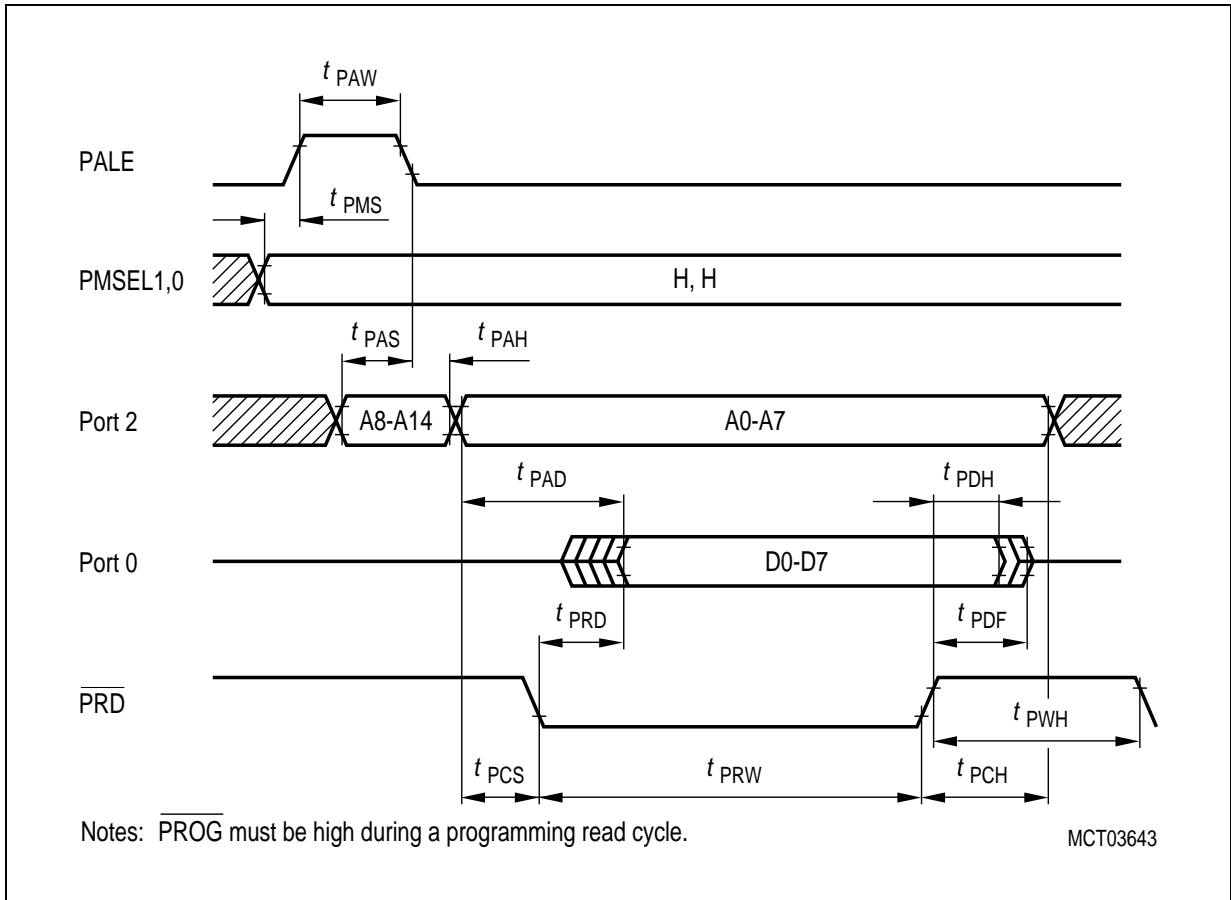

Figure 37
Verify Code Byte - Read Cycle Timing

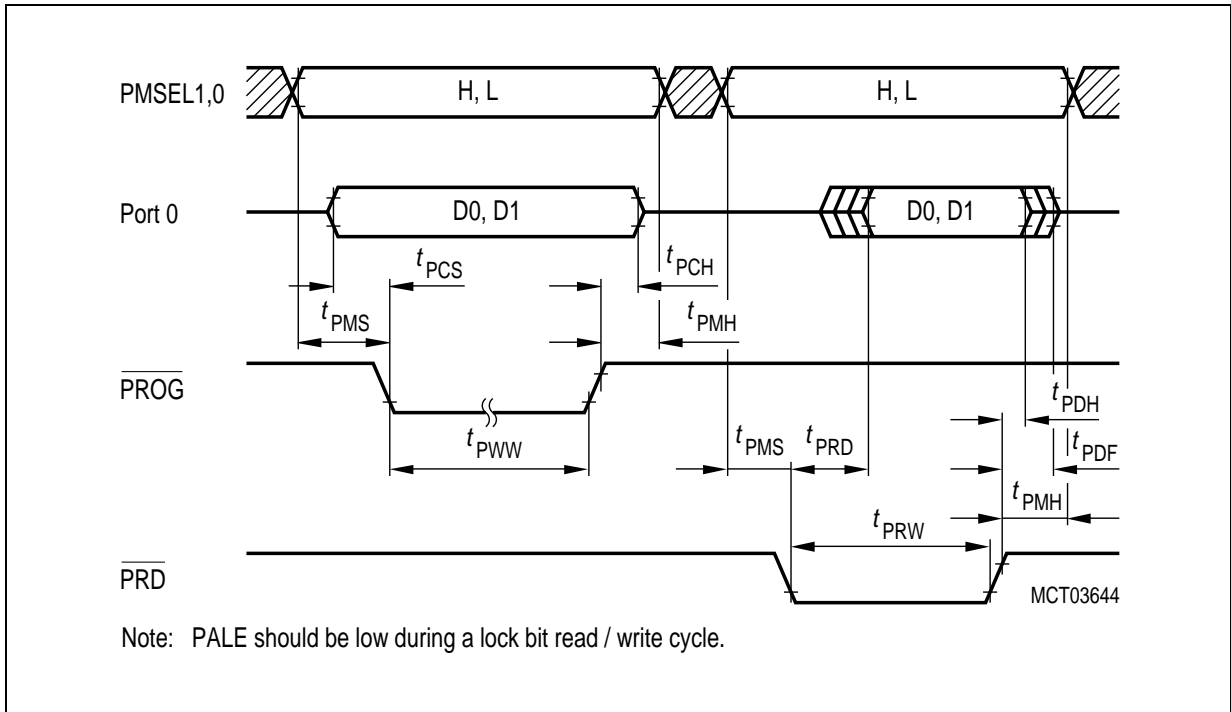

Figure 38
Lock Bit Access Timing

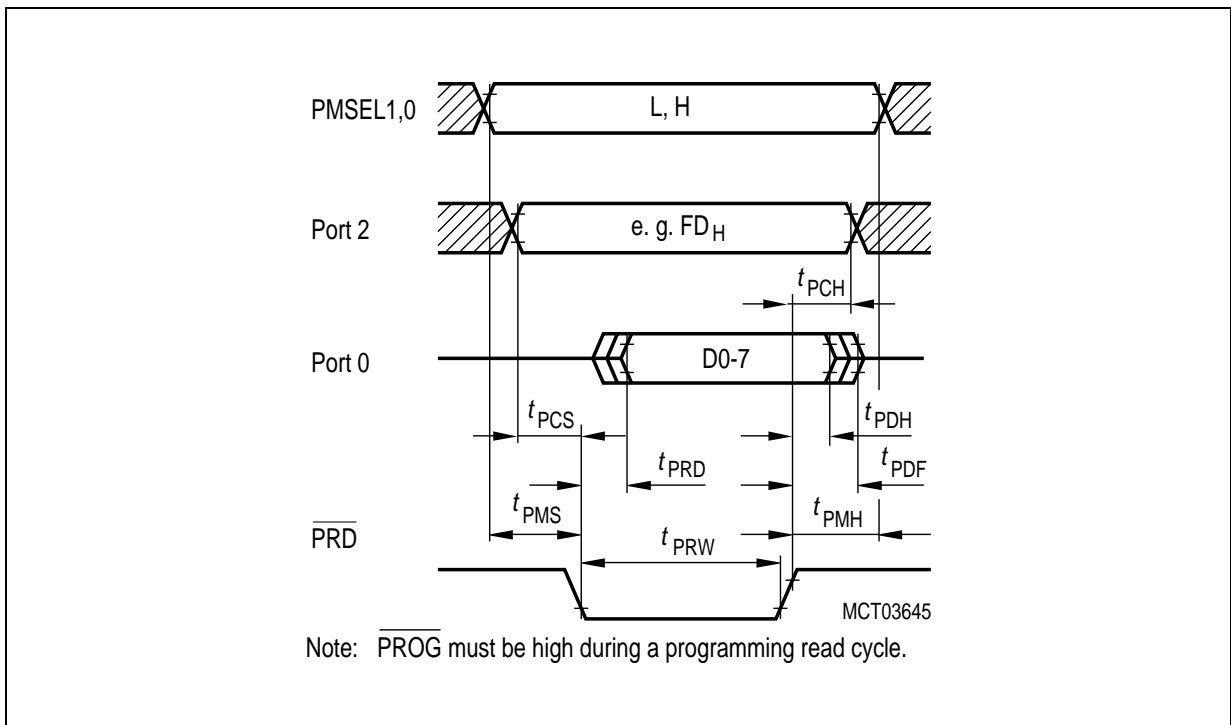

Figure 39
Version Byte Read Timing

ROM/OTP Verification Characteristics for C505

ROM Verification Mode 1 (C505(C)(A)-2R and C505(C)A-4R only)

Parameter	Symbol	Limit Values		Unit
		min.	max.	
Address to valid data	t_{AVQV}	–	5 CLP	ns

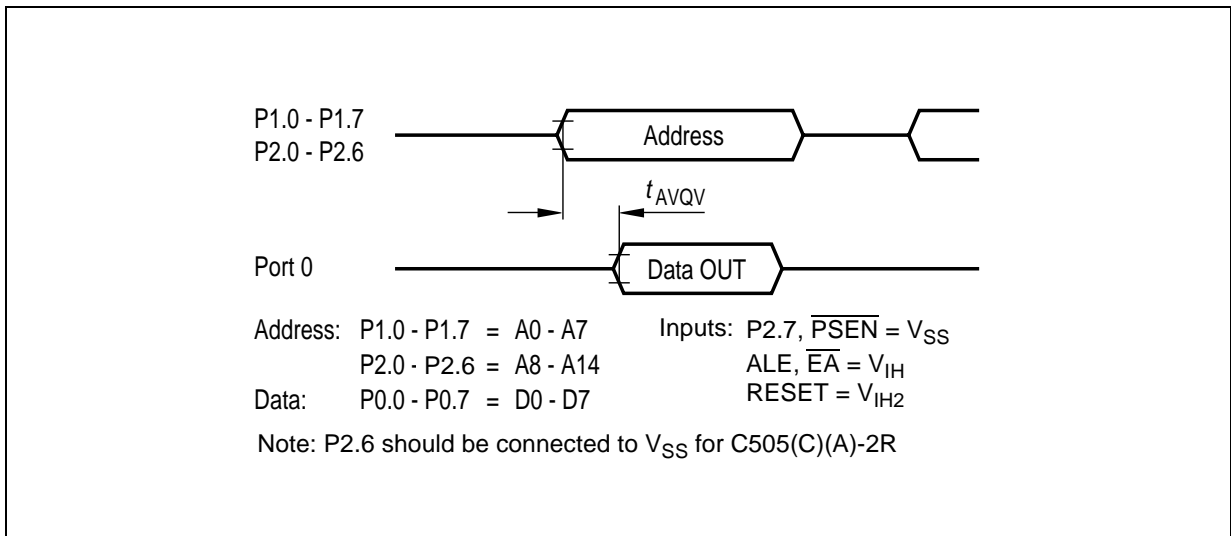

Figure 40
ROM Verification Mode 1

ROM/OTP Verification Characteristics for C505 (cont'd)

ROM/OTP Verification Mode 2

Parameter	Symbol	Limit Values			Unit
		min.	typ	max.	
ALE pulse width	t_{AWD}	–	CLP	–	ns
ALE period	t_{ACY}	–	6 CLP	–	ns
Data valid after ALE	t_{DVA}	–	–	2 CLP	ns
Data stable after ALE	t_{DSA}	4 CLP	–	–	ns
P3.5 setup to ALE low	t_{AS}	–	t_{CL}	–	ns
Oscillator frequency	1/ CLP	4	–	6	MHz

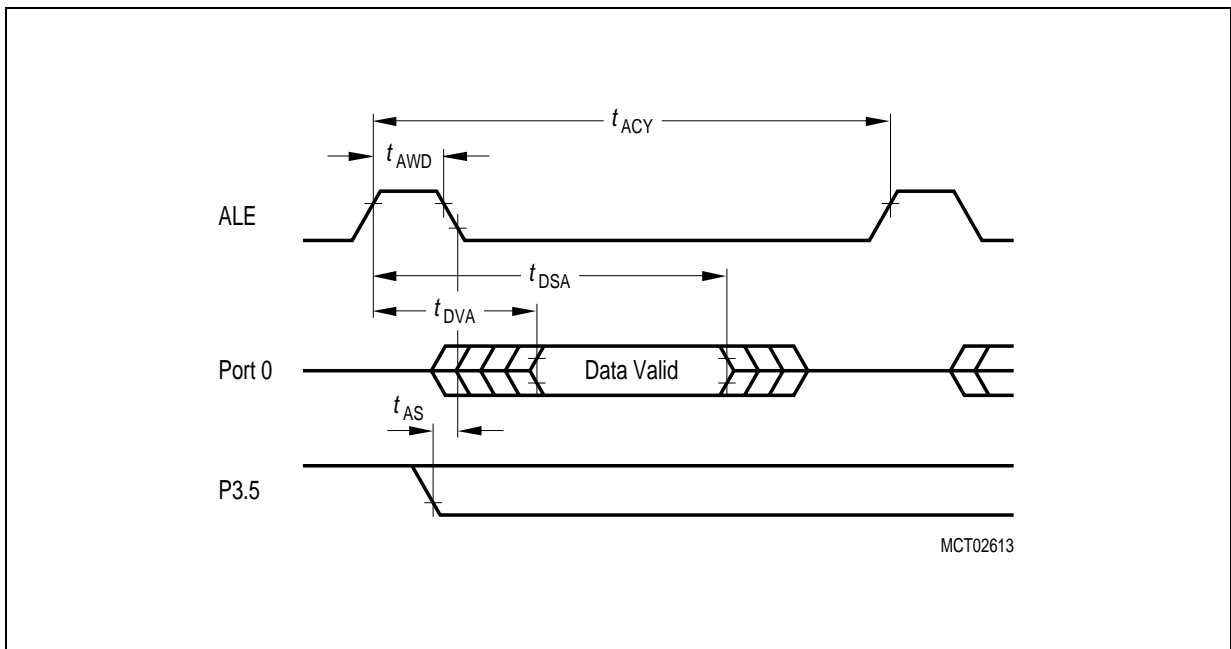

Figure 41
ROM/OTP Verification Mode 2

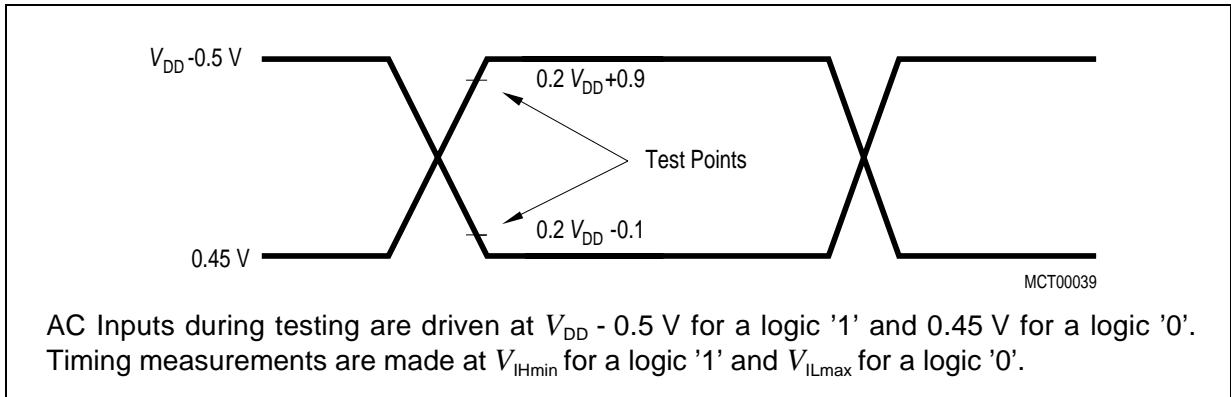

Figure 42
AC Testing: Input, Output Waveforms

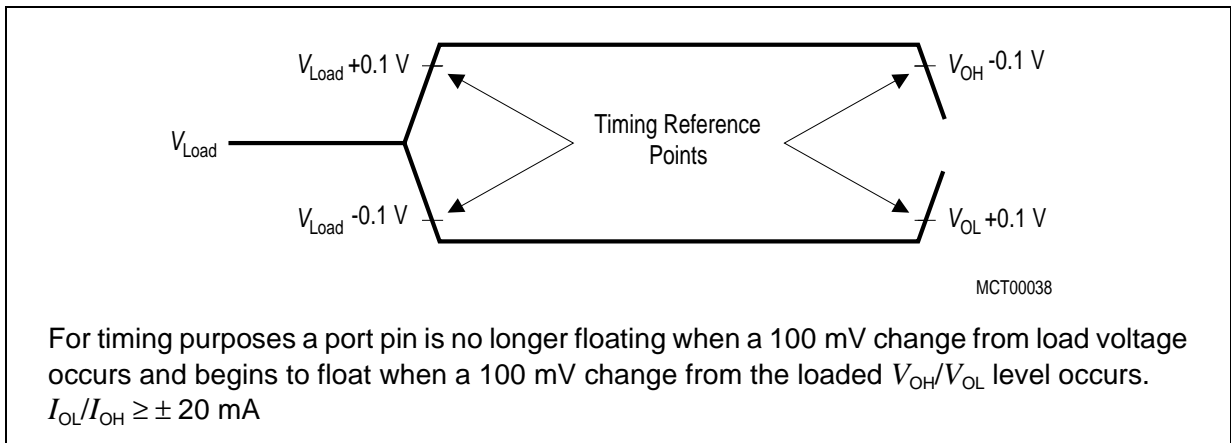

Figure 43
AC Testing : Float Waveforms

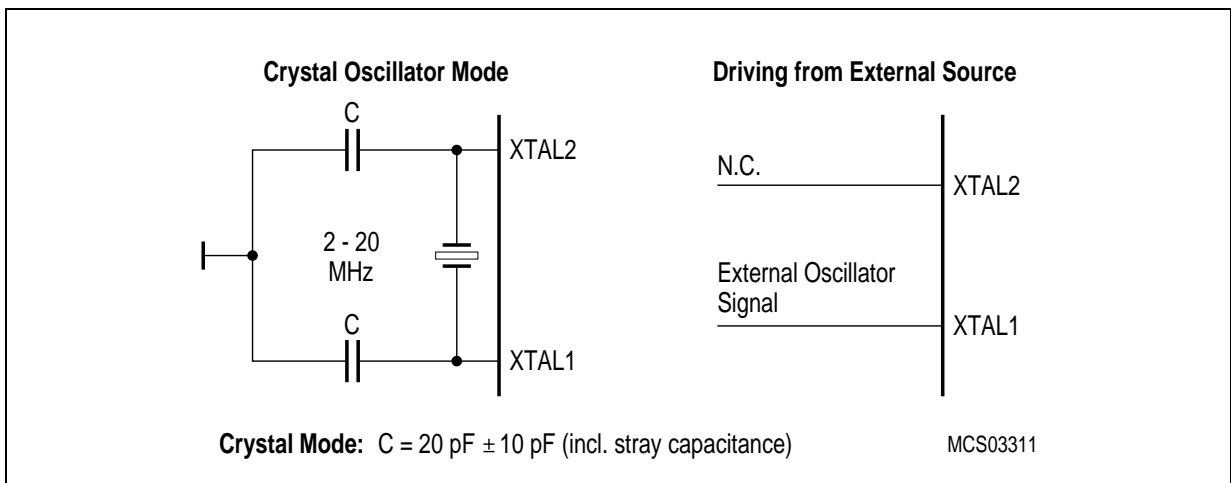

Figure 44
Recommended Oscillator Circuits for Crystal Oscillator

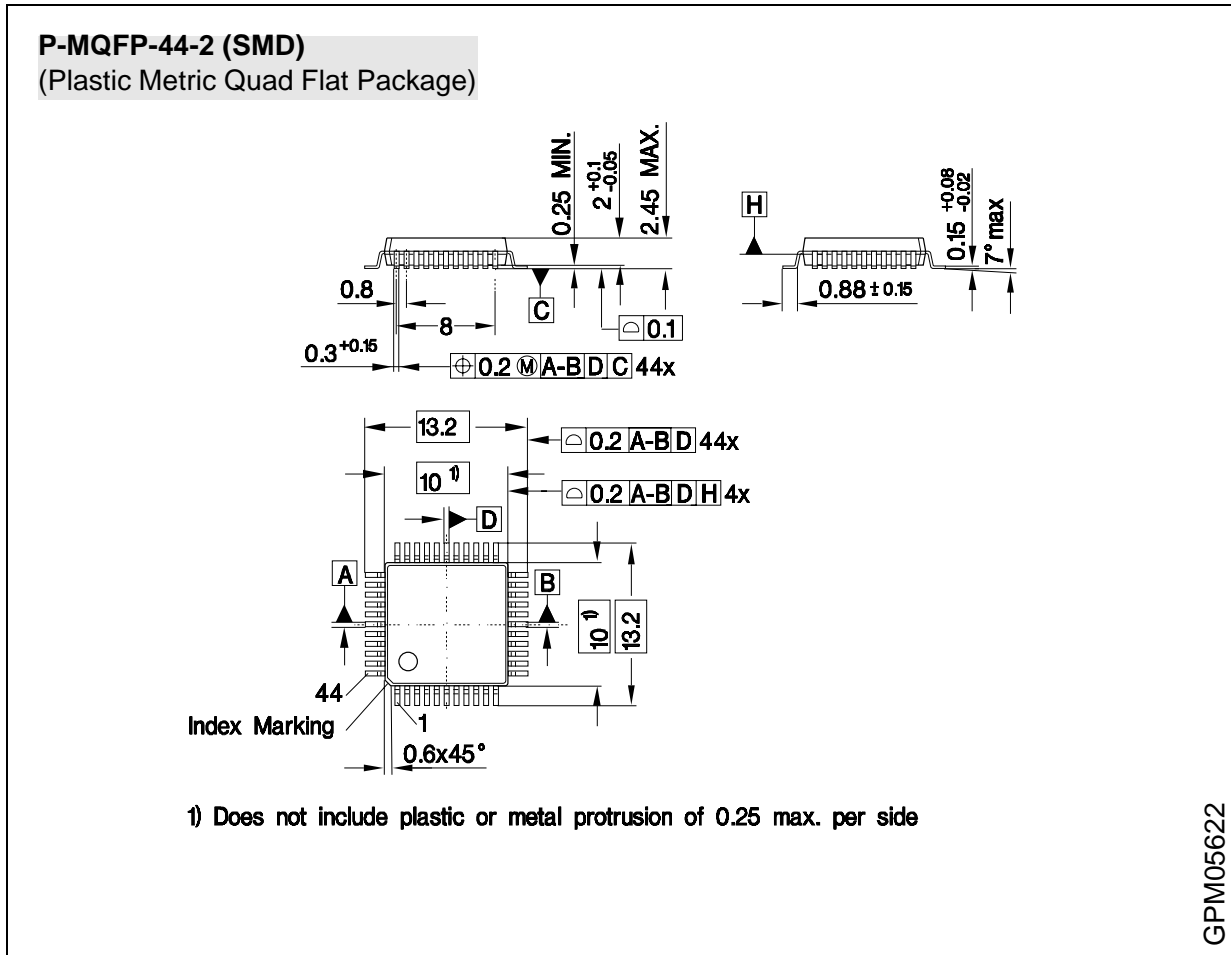

Figure 45
P-MQFP-44 Package Outline

Sorts of Packing

Package outlines for tubes, trays etc. are contained in our Data Book "Package Information"
SMD = Surface Mounted Device

Dimensions in mm

Infineon goes for Business Excellence

“Business excellence means intelligent approaches and clearly defined processes, which are both constantly under review and ultimately lead to good operating results.

Better operating results and business excellence mean less idleness and wastefulness for all of us, more professional success, more accurate information, a better overview and, thereby, less frustration and more satisfaction.”

Dr. Ulrich Schumacher

<http://www.infineon.com>

Published by Infineon Technologies AG