

LM3410

PowerWise® 525kHz/1.6MHz, Constant Current Boost and SEPIC LED Driver with Internal Compensation

General Description

The LM3410 constant current LED driver is a monolithic, high frequency, PWM DC/DC converter in 5-pin SOT23, 6-pin LLP, & 8-pin eMSOP packages. With a minimum of external components the LM3410 is easy to use. It can drive 2.8A typical peak currents with an internal 170 mΩ NMOS switch. Switching frequency is internally set to either 525 kHz or 1.60 MHz, allowing the use of extremely small surface mount inductors and chip capacitors. Even though the operating frequency is high, efficiencies up to 88% are easy to achieve. External shutdown is included, featuring an ultra-low standby current of 80 nA. The LM3410 utilizes current-mode control and internal compensation to provide high-performance over a wide range of operating conditions. Additional features include dimming, cycle-by-cycle current limit, and thermal shutdown.

Features

- Space Saving SOT23-5 & 6-LLP Package
- Input voltage range of 2.7V to 5.5V
- Output voltage range of 3V to 24V
- 2.8A Typical Switch Current
- High Switching Frequency
 - 525 KHz (LM3410-Y)
 - 1.6 MHz (LM3410-X)
- 170 mΩ NMOS Switch
- 190 mV Internal Voltage Reference
- Internal Soft-Start
- Current-Mode, PWM Operation
- Thermal Shutdown

Applications

- LED Backlight Current Source
- Lilon Backlight OLED & HB LED Driver
- Handheld Devices
- LED Flash Driver

Typical Boost Application Circuit

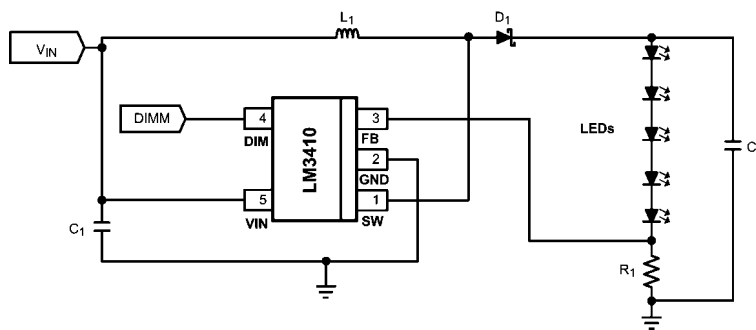

30038501

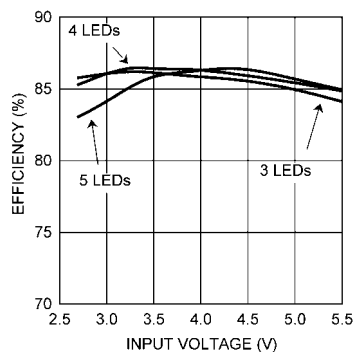

30038502

Connection Diagrams

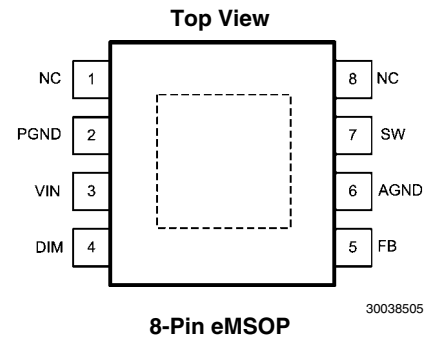
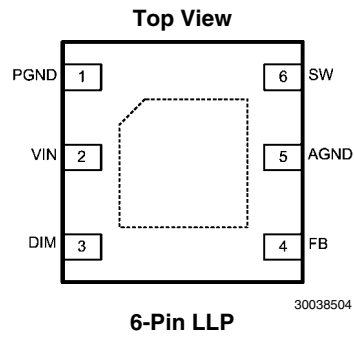
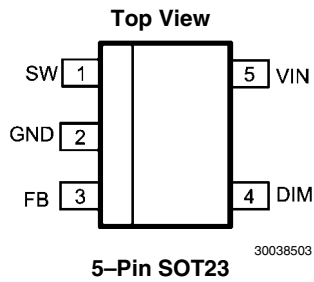

Ordering Information

| Order Number | Frequency | Package Type | Package Drawing | Supplied As |
|--------------|-----------|--------------|-----------------|------------------------|
| LM3410YMF | 525 kHz | SOT23-5 | MF05A | 1000 units Tape & Reel |
| LM3410YMFY | | | | 3000 units Tape & Reel |
| LM3410YSD | | LLP-6 | SDE06A | 1000 units Tape & Reel |
| LM3410YSDX | | | | 4500 units Tape & Reel |
| LM3410YMY | | eMSOP-8 | MUJ08A | 1000 units Tape & Reel |
| LM3410YMYX | | | | 3500 units Tape & Reel |
| LM3410XMF | 1.6 MHz | SOT23-5 | MF05A | 1000 units Tape & Reel |
| LM3410XMFY | | | | 3000 units Tape & Reel |
| LM3410XSD | | LLP-6 | SDE06A | 1000 units tape & reel |
| LM3410XSDX | | | | 4500 units Tape & Reel |
| LM3410XMY | | eMSOP-8 | MUJ08A | 1000 units Tape & Reel |
| LM3410XMYX | | | | 3500 units Tape & Reel |

Pin Descriptions - 5-Pin SOT23

| Pin | Name | Function |
|-----|------|--|
| 1 | SW | Output switch. Connect to the inductor, output diode. |
| 2 | GND | Signal and power ground pin. Place the bottom resistor of the feedback network as close as possible to this pin. |
| 3 | FB | Feedback pin. Connect FB to external resistor divider to set output voltage. |
| 4 | DIM | Dimming & shutdown control input. Logic high enables operation. Duty Cycle from 0 to 100%. Do not allow this pin to float or be greater than VIN + 0.3V. |
| 5 | VIN | Supply voltage pin for power stage, and input supply voltage. |

Pin Descriptions - 6-Pin LLP

| Pin | Name | Function |
|-----|------|--|
| 1 | PGND | Power ground pin. Place PGND and output capacitor GND close together. |
| 2 | VIN | Supply voltage for power stage, and input supply voltage. |
| 3 | DIM | Dimming & shutdown control input. Logic high enables operation. Duty Cycle from 0 to 100%. Do not allow this pin to float or be greater than VIN + 0.3V. |
| 4 | FB | Feedback pin. Connect FB to external resistor divider to set output voltage. |
| 5 | AGND | Signal ground pin. Place the bottom resistor of the feedback network as close as possible to this pin & pin 4. |
| 6 | SW | Output switch. Connect to the inductor, output diode. |
| DAP | GND | Signal & Power ground. Connect to pin 1 & pin 5 on top layer. Place 4-6 vias from DAP to bottom layer GND plane. |

Pin Descriptions - 8-Pin eMSOP

| Pin | Name | Function |
|-----|------|--|
| 1 | - | No Connect |
| 2 | PGND | Power ground pin. Place PGND and output capacitor GND close together. |
| 3 | VIN | Supply voltage for power stage, and input supply voltage. |
| 4 | DIM | Dimming & shutdown control input. Logic high enables operation. Duty Cycle from 0 to 100%. Do not allow this pin to float or be greater than VIN + 0.3V. |
| 5 | FB | Feedback pin. Connect FB to external resistor divider to set output voltage. |
| 6 | AGND | Signal ground pin. Place the bottom resistor of the feedback network as close as possible to this pin & pin 5 |
| 7 | SW | Output switch. Connect to the inductor, output diode. |
| 8 | - | No Connect |
| DAP | GND | Signal & Power ground. Connect to pin 2 & pin 6 on top layer. Place 4-6 vias from DAP to bottom layer GND plane. |

Absolute Maximum Ratings (Note 1)

If Military/Aerospace specified devices are required, please contact the National Semiconductor Sales Office/Distributors for availability and specifications.

| | |
|-------------------------------|----------------|
| V_{IN} | -0.5V to 7V |
| SW Voltage | -0.5V to 26.5V |
| FB Voltage | -0.5V to 3.0V |
| DIM Voltage | -0.5V to 7.0V |
| ESD Susceptibility (Note 4) | |
| Human Body Model | 2kV |
| Junction Temperature (Note 2) | 150°C |

| | |
|------------------------------------|----------------|
| Storage Temp. Range | -65°C to 150°C |
| Soldering Information | |
| Infrared/Convection Reflow (15sec) | 220°C |

Operating Ratings (Note 1)

| | |
|--------------------------------------|----------------|
| V_{IN} | 2.7V to 5.5V |
| V_{DIM} (Note 5) | 0V to V_{IN} |
| V_{SW} | 3V to 24V |
| Junction Temperature Range | -40°C to 125°C |
| Power Dissipation (Internal) SOT23-5 | 400 mW |

Electrical Characteristics Limits in standard type are for $T_J = 25^\circ\text{C}$ only; limits in **boldface type** apply over the junction temperature (T_J) range of -40°C to 125°C . Minimum and Maximum limits are guaranteed through test, design, or statistical correlation. Typical values represent the most likely parametric norm at $T_J = 25^\circ\text{C}$, and are provided for reference purposes only. $V_{IN} = 5\text{V}$, unless otherwise indicated under the Conditions column.

| Symbol | Parameter | Conditions | Min | Typ | Max | Units |
|------------------------|----------------------------------|--|-------------|------|-------------|------------------|
| V_{FB} | Feedback Voltage | | 178 | 190 | 202 | mV |
| $\Delta V_{FB}/V_{IN}$ | Feedback Voltage Line Regulation | $V_{IN} = 2.7\text{V to } 5.5\text{V}$ | - | 0.06 | - | %/V |
| I_{FB} | Feedback Input Bias Current | | - | 0.1 | 1 | μA |
| F_{SW} | Switching Frequency | LM3410-X | 1200 | 1600 | 2000 | kHz |
| | | LM3410-Y | 360 | 525 | 680 | |
| D_{MAX} | Maximum Duty Cycle | LM3410-X | 88 | 92 | - | % |
| | | LM3410-Y | 90 | 95 | - | |
| D_{MIN} | Minimum Duty Cycle | LM3410-X | - | 5 | - | % |
| | | LM3410-Y | - | 2 | - | |
| $R_{DS(ON)}$ | Switch On Resistance | SOT23-5 and eMSOP-8 | - | 170 | 330 | $\text{m}\Omega$ |
| | | LLP-6 | - | 190 | 350 | |
| I_{CL} | Switch Current Limit | | 2.1 | 2.80 | - | A |
| SU | Start Up Time | | - | 20 | - | μs |
| I_Q | Quiescent Current (switching) | LM3410-X $V_{FB} = 0.25$ | - | 7.0 | 11 | mA |
| | | LM3410-Y $V_{FB} = 0.25$ | - | 3.4 | 7 | |
| | Quiescent Current (shutdown) | All Options $V_{DIM} = 0\text{V}$ | - | 80 | - | nA |
| UVLO | Undervoltage Lockout | V_{IN} Rising | - | 2.3 | 2.65 | V |
| | | V_{IN} Falling | 1.7 | 1.9 | - | |
| V_{DIM_H} | Shutdown Threshold Voltage | | - | - | 0.4 | V |
| | Enable Threshold Voltage | | 1.8 | - | - | |
| I_{SW} | Switch Leakage | $V_{SW} = 24\text{V}$ | - | 1.0 | - | μA |
| I_{DIM} | Dimming Pin Current | Sink/Source | - | 100 | - | nA |

| Symbol | Parameter | Conditions | Min | Typ | Max | Units |
|---------------|---|---------------------------|-----|-----|-----|-------|
| θ_{JA} | Junction to Ambient 0 LFPM Air Flow (Note 3) | LLP-6 and eMSOP-8 Package | - | 80 | - | °C/W |
| | | SOT23-5 Package | - | 118 | - | |
| θ_{JC} | Junction to Case (Note 3) | LLP-6 and eMSOP-8 Package | - | 18 | - | °C/W |
| | | SOT23-5 Package | - | 60 | - | |
| T_{SD} | Thermal Shutdown Temperature (Note 2) | | - | 165 | - | °C |

Note 1: Absolute Maximum Ratings indicate limits beyond which damage to the device may occur. Operating Ratings indicate conditions for which the device is intended to be functional, but does not guarantee specific performance limits. For guaranteed specifications and conditions, see the Electrical Characteristics.

Note 2: Thermal shutdown will occur if the junction temperature exceeds the maximum junction temperature of the device.

Note 3: Applies for packages soldered directly onto a 3" x 3" PC board with 2oz. copper on 4 layers in still air.

Note 4: The human body model is a 100 pF capacitor discharged through a 1.5 k Ω resistor into each pin. Test method is per JESD22-A114.

Note 5: Do not allow this pin to float or be greater than $V_{IN} + 0.3V$.

Typical Performance Characteristics All curves taken at $V_{IN} = 5.0V$ with configuration in typical application circuit shown in Application Information section of this datasheet. $T_J = 25C$, unless otherwise specified.

LM3410-X Efficiency vs V_{IN} ($R_{SET} = 4\Omega$)

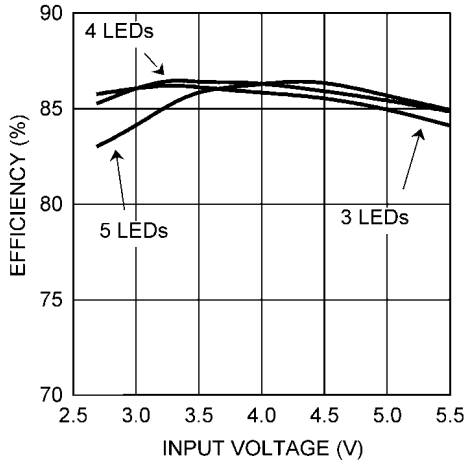

30038502

LM3410-X Start-Up Signature

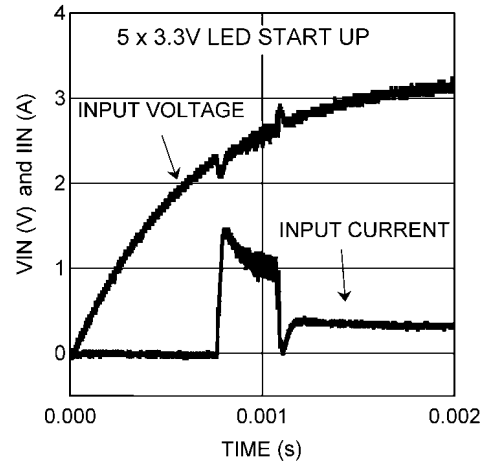

30038507

4 x 3.3V LEDs 500 Hz DIM FREQ D = 50%

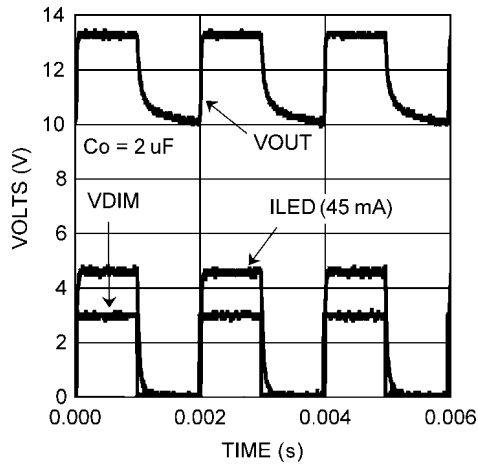

30038508

DIM Freq & Duty Cycle vs Avg I-LED

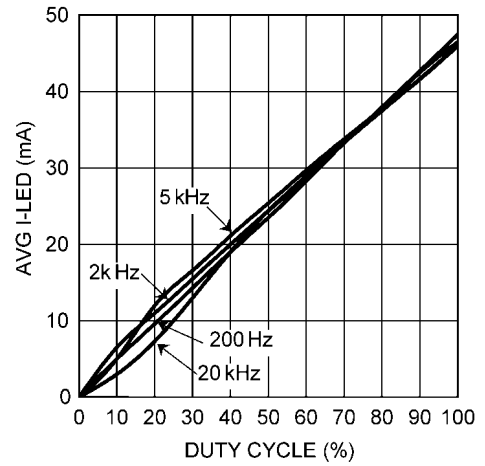

30038509

Current Limit vs Temperature

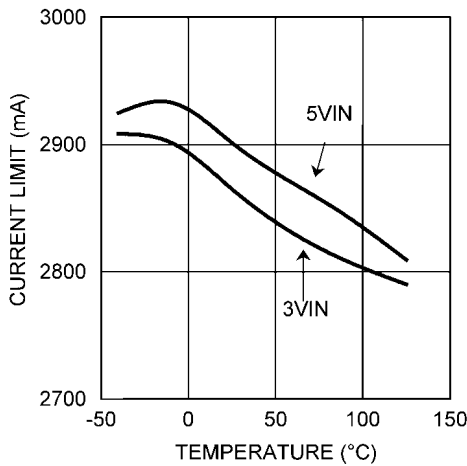

30038510

R_{DSON} vs Temperature

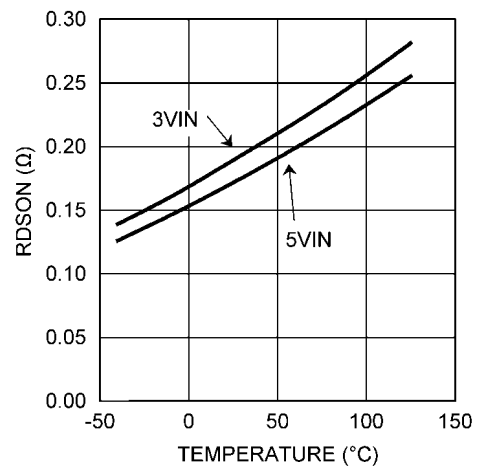

30038511

Oscillator Frequency vs Temperature - "X"

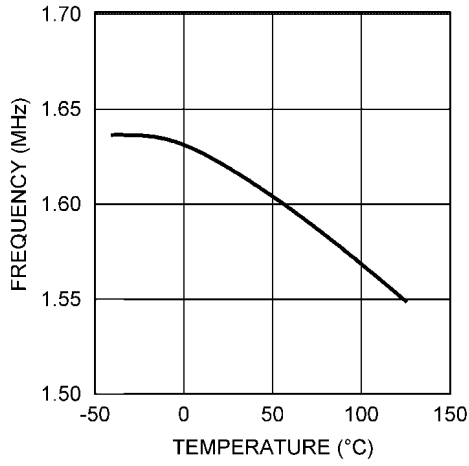

30038512

Oscillator Frequency vs Temperature - "Y"

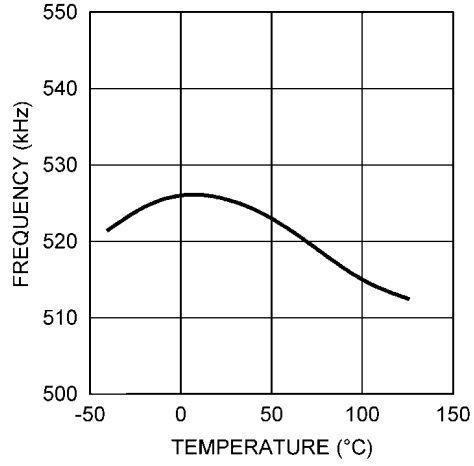

30038513

V_{FB} vs Temperature

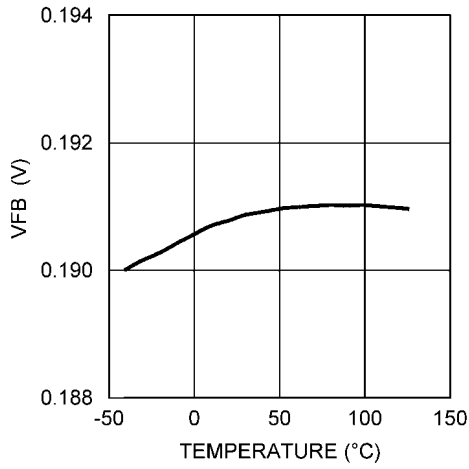

30038580

Simplified Internal Block Diagram

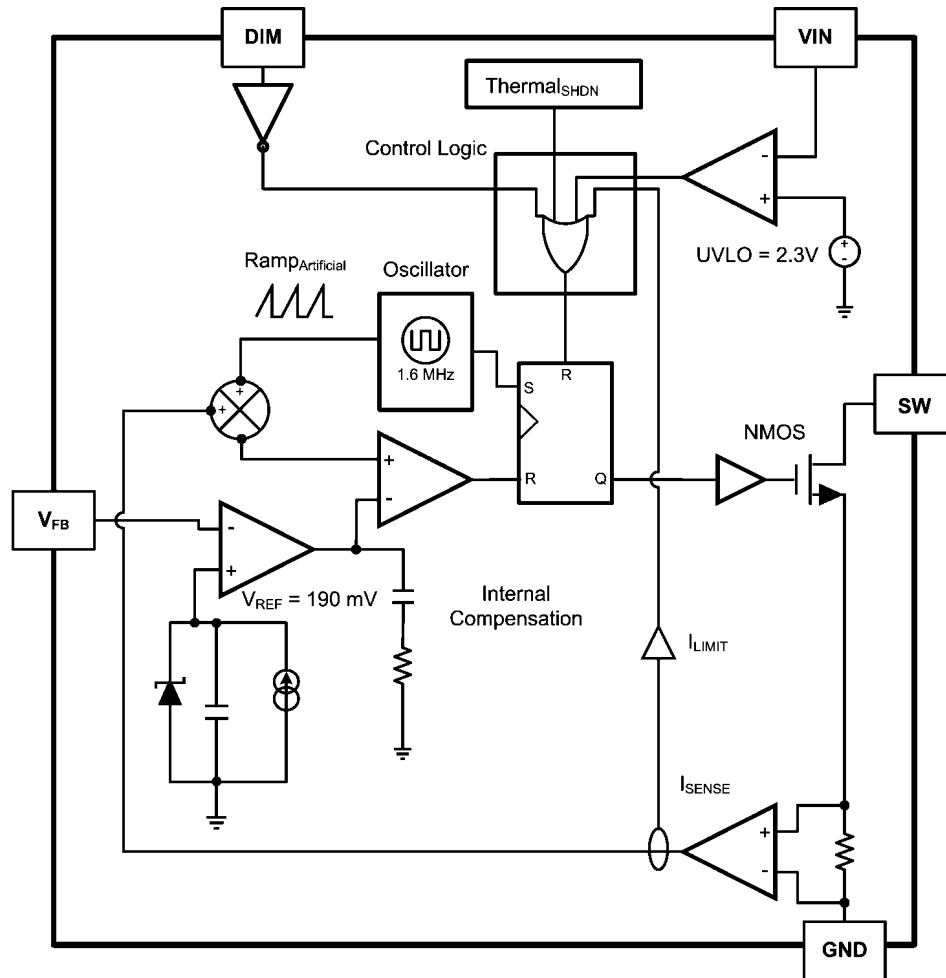

30038514

FIGURE 1. Simplified Block Diagram

Application Information

THEORY OF OPERATION

The LM3410 is a constant frequency PWM, boost regulator IC. It delivers a minimum of 2.1A peak switch current. The device operates very similar to a voltage regulated boost converter except that it regulates the output current through LEDs. The current magnitude is set with a series resistor. This series resistor multiplied by the LED current creates the feedback voltage (190 mV) which the converter regulates to. The regulator has a preset switching frequency of either 525 kHz or 1.60 MHz. This high frequency allows the LM3410 to operate with small surface mount capacitors and inductors, resulting in a DC/DC converter that requires a minimum amount of board space. The LM3410 is internally compensated, so it is simple to use, and requires few external components. The LM3410 uses current-mode control to regulate the LED current. The following operating description of the LM3410 will refer to the Simplified Block Diagram (Figure 1) the simplified schematic (Figure 2), and its associated waveforms (Figure 3). The LM3410 supplies a regulated LED current by switching the internal NMOS control switch at constant frequency and variable duty cycle. A switching cycle

begins at the falling edge of the reset pulse generated by the internal oscillator. When this pulse goes low, the output control logic turns on the internal NMOS control switch. During this on-time, the SW pin voltage (V_{SW}) decreases to approximately GND, and the inductor current (I_L) increases with a linear slope. I_L is measured by the current sense amplifier, which generates an output proportional to the switch current. The sensed signal is summed with the regulator's corrective ramp and compared to the error amplifier's output, which is proportional to the difference between the feedback voltage and V_{REF} . When the PWM comparator output goes high, the output switch turns off until the next switching cycle begins. During the switch off-time, inductor current discharges through diode D1, which forces the SW pin to swing to the output voltage plus the forward voltage (V_D) of the diode. The regulator loop adjusts the duty cycle (D) to maintain a regulated LED current.

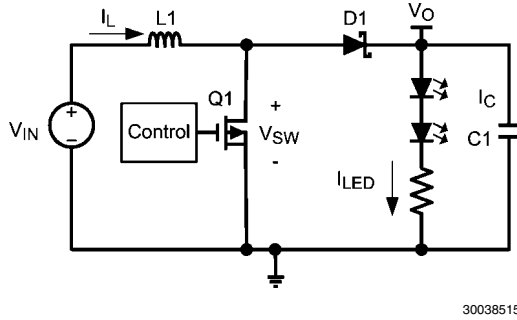

30038515

FIGURE 2. Simplified Boost Topology Schematic

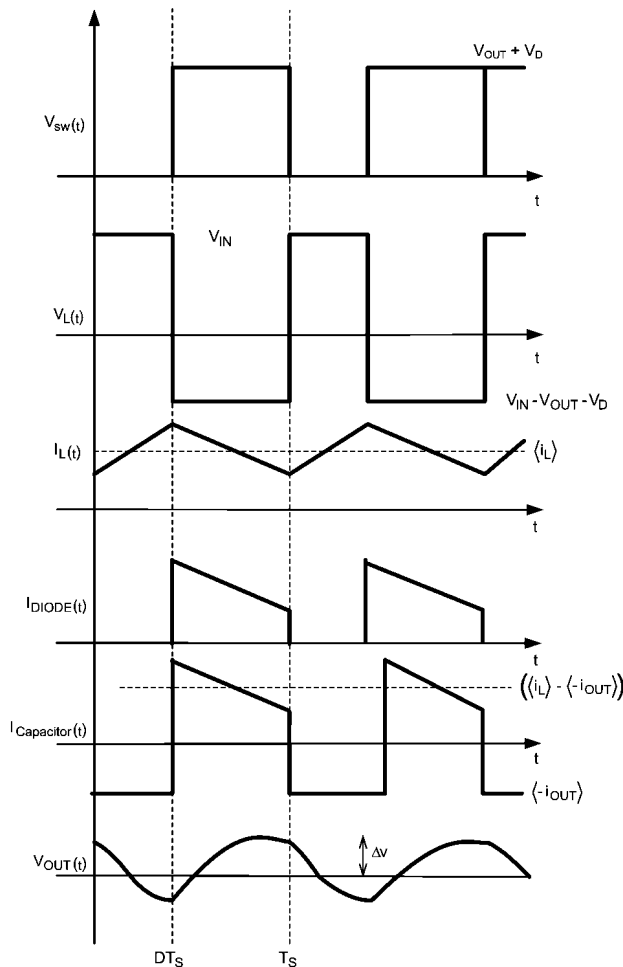

30038516

FIGURE 3. Typical Waveforms

CURRENT LIMIT

The LM3410 uses cycle-by-cycle current limiting to protect the internal NMOS switch. It is important to note that this current limit will not protect the output from excessive current during an output short circuit. The input supply is connected to the output by the series connection of an inductor and a diode. If a short circuit is placed on the output, excessive current can damage both the inductor and diode.

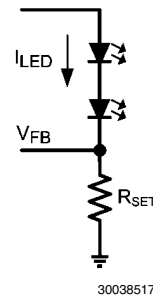
Design Guide**SETTING THE LED CURRENT**

30038517

FIGURE 4. Setting I_{LED}

The LED current is set using the following equation:

$$\frac{V_{FB}}{R_{SET}} = I_{LED}$$

where R_{SET} is connected between the FB pin and GND.

DIM PIN / SHUTDOWN MODE

The average LED current can be controlled using a PWM signal on the DIM pin. The duty cycle can be varied between 0 & 100% to either increase or decrease LED brightness. PWM frequencies in the range of 1 Hz to 25 kHz can be used. For controlling LED currents down to the μA levels, it is best to use a PWM signal frequency between 200-1 kHz. The maximum LED current would be achieved using a 100% duty cycle, i.e. the DIM pin always high.

LED-DRIVE CAPABILITY

When using the LM3410 in the typical application configuration, with LEDs stacked in series between the V_{OUT} and FB pin, the maximum number of LEDs that can be placed in series is dependent on the maximum LED forward voltage ($V_{F_{MAX}}$).

$$(V_{F_{MAX}} \times N_{LEDs}) + 190 \text{ mV} < 24 \text{ V}$$

When inserting a value for maximum $V_{F_{MAX}}$ the LED forward voltage variation over the operating temperature range should be considered.

THERMAL SHUTDOWN

Thermal shutdown limits total power dissipation by turning off the output switch when the IC junction temperature exceeds 165°C. After thermal shutdown occurs, the output switch doesn't turn on until the junction temperature drops to approximately 150°C.

INDUCTOR SELECTION

The inductor value determines the input ripple current. Lower inductor values decrease the physical size of the inductor, but increase the input ripple current. An increase in the inductor value will decrease the input ripple current.

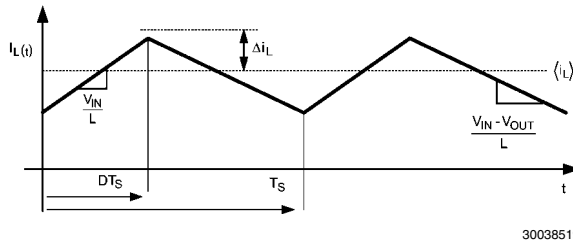

FIGURE 5. Inductor Current

$$\frac{2\Delta i_L}{DT_s} = \left(\frac{V_{IN}}{L} \right)$$

$$\Delta i_L = \left(\frac{V_{IN}}{2L} \right) \times DT_s$$

The Duty Cycle (D) for a Boost converter can be approximated by using the ratio of output voltage (V_{OUT}) to input voltage (V_{IN}).

$$\frac{V_{OUT}}{V_{IN}} = \left(\frac{1}{1-D} \right) = \frac{1}{D'}$$

Therefore:

$$D = \frac{V_{OUT} - V_{IN}}{V_{OUT}}$$

Power losses due to the diode (D1) forward voltage drop, the voltage drop across the internal NMOS switch, the voltage drop across the inductor resistance (R_{DCR}) and switching losses must be included to calculate a more accurate duty cycle (See **Calculating Efficiency and Junction Temperature** for a detailed explanation). A more accurate formula for calculating the conversion ratio is:

$$\frac{V_{OUT}}{V_{IN}} = \frac{\eta}{D'}$$

Where η equals the efficiency of the LM3410 application.

Or:

$$\eta = \frac{V_{OUT} \times I_{LED}}{V_{IN} \times I_{IN}}$$

Therefore:

$$D = \frac{V_{OUT} - \eta V_{IN}}{V_{OUT}}$$

Inductor ripple in a LED driver circuit can be greater than what would normally be allowed in a voltage regulator Boost & Sepic design. A good design practice is to allow the inductor to produce 20% to 50% ripple of maximum load. The increased ripple shouldn't be a problem when illuminating LEDs.

From the previous equations, the inductor value is then obtained.

$$L = \left(\frac{V_{IN}}{2\Delta i_L} \right) \times DT_s$$

Where

$$1/T_s = f_{SW}$$

One must also ensure that the minimum current limit (2.1A) is not exceeded, so the peak current in the inductor must be calculated. The peak current (I_{pk}) in the inductor is calculated by:

$$I_{Lpk} = I_{IN} + \Delta i_L \text{ or } I_{Lpk} = I_{OUT}/D' + \Delta i_L$$

When selecting an inductor, make sure that it is capable of supporting the peak input current without saturating. Inductor saturation will result in a sudden reduction in inductance and prevent the regulator from operating correctly. Because of the speed of the internal current limit, the peak current of the inductor need only be specified for the required maximum input current. For example, if the designed maximum input current is 1.5A and the peak current is 1.75A, then the inductor should be specified with a saturation current limit of >1.75A. There is no need to specify the saturation or peak current of the inductor at the 2.8A typical switch current limit.

Because of the operating frequency of the LM3410, ferrite based inductors are preferred to minimize core losses. This presents little restriction since the variety of ferrite-based inductors is huge. Lastly, inductors with lower series resistance (DCR) will provide better operating efficiency. For recommended inductors see **Example Circuits**.

INPUT CAPACITOR

An input capacitor is necessary to ensure that V_{IN} does not drop excessively during switching transients. The primary specifications of the input capacitor are capacitance, voltage, RMS current rating, and ESL (Equivalent Series Inductance). The recommended input capacitance is 2.2 μ F to 22 μ F depending on the application. The capacitor manufacturer specifically states the input voltage rating. Make sure to check any recommended deratings and also verify if there is any significant change in capacitance at the operating input voltage and the operating temperature. The ESL of an input capacitor is usually determined by the effective cross sectional area of the current path. At the operating frequencies of the LM3410, certain capacitors may have an ESL so large that the resulting impedance ($2\pi fL$) will be higher than that required to provide stable operation. As a result, surface mount capacitors are strongly recommended. Multilayer ceramic capacitors (MLCC) are good choices for both input and output capacitors and have very low ESL. For MLCCs it is recommended to use X7R or X5R dielectrics. Consult capacitor manufacturer datasheet to see how rated capacitance varies over operating conditions.

OUTPUT CAPACITOR

The LM3410 operates at frequencies allowing the use of ceramic output capacitors without compromising transient response. Ceramic capacitors allow higher inductor ripple without significantly increasing output ripple. The output capacitor is selected based upon the desired output ripple and transient response. The initial current of a load transient is provided mainly by the output capacitor. The output impedance will therefore determine the maximum voltage perturbation. The output ripple of the converter is a function

of the capacitor's reactance and its equivalent series resistance (ESR):

$$\Delta V_{OUT} = \Delta i_L \times R_{ESR} + \left(\frac{V_{OUT} \times D}{2 \times f_{SW} \times R_{OUT} \times C_{OUT}} \right)$$

When using MLCCs, the ESR is typically so low that the capacitive ripple may dominate. When this occurs, the output ripple will be approximately sinusoidal and 90° phase shifted from the switching action.

Given the availability and quality of MLCCs and the expected output voltage of designs using the LM3410, there is really no need to review any other capacitor technologies. Another benefit of ceramic capacitors is their ability to bypass high frequency noise. A certain amount of switching edge noise will couple through parasitic capacitances in the inductor to the output. A ceramic capacitor will bypass this noise while a tantalum will not. Since the output capacitor is one of the two external components that control the stability of the regulator control loop, most applications will require a minimum of 0.47 μF of output capacitance. Like the input capacitor, recommended multilayer ceramic capacitors are X7R or X5R. Again, verify actual capacitance at the desired operating voltage and temperature.

DIODE

The diode (D1) conducts during the switch off time. A Schottky diode is recommended for its fast switching times and low forward voltage drop. The diode should be chosen so that its current rating is greater than:

$$I_{D1} \geq I_{OUT}$$

The reverse breakdown rating of the diode must be at least the maximum output voltage plus appropriate margin.

OUTPUT OVER-VOLTAGE PROTECTION

A simple circuit consisting of an external zener diode can be implemented to protect the output and the LM3410 device from an over-voltage fault condition. If an LED fails open, or is connected backwards, an output open circuit condition will occur. No current is conducted through the LED's, and the feedback node will equal zero volts. The LM3410 will react to this fault by increasing the duty-cycle, thinking the LED current has dropped. A simple circuit that protects the LM3410 is shown in figure 6.

Zener diode D2 and resistor R3 is placed from V_{OUT} in parallel with the string of LEDs. If the output voltage exceeds the breakdown voltage of the zener diode, current is drawn through the zener diode, R3 and sense resistor R1. Once the voltage across R1 and R3 equals the feedback voltage of 190mV, the LM3410 will limit its duty-cycle. No damage will occur to the LM3410, the LED's, or the zener diode. Once the fault is corrected, the application will work as intended.

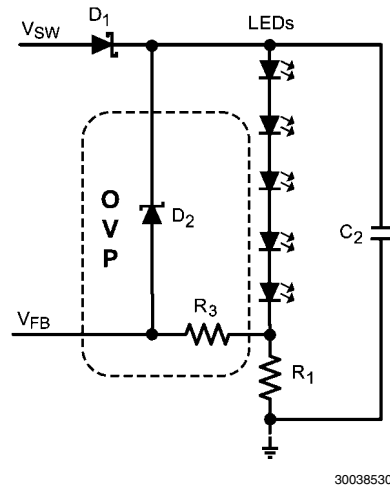

FIGURE 6. Overvoltage Protection Circuit

PCB Layout Considerations

When planning layout there are a few things to consider when trying to achieve a clean, regulated output. The most important consideration when completing a Boost Converter layout is the close coupling of the GND connections of the C_{OUT} capacitor and the LM3410 PGND pin. The GND ends should be close to one another and be connected to the GND plane with at least two through-holes. There should be a continuous ground plane on the bottom layer of a two-layer board except under the switching node island. The FB pin is a high impedance node and care should be taken to make the FB trace short to avoid noise pickup and inaccurate regulation. The R_{SET} feedback resistor should be placed as close as possible to the IC, with the AGND (R1) placed as close as possible to the AGND (pin 5 for the LLP) of the IC. Radiated noise can be decreased by choosing a shielded inductor. The remaining components should also be placed as close as possible to the IC. Please see Application Note AN-1229 for further considerations and the LM3410 demo board as an example of a four-layer layout.

Below is an example of a good thermal & electrical PCB design.

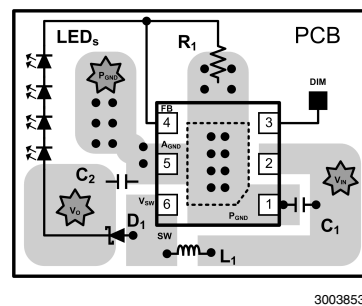

FIGURE 7. Boost PCB Layout Guidelines

This is very similar to our LM3410 demonstration boards that are obtainable via the National Semiconductor website. The demonstration board consists of a two layer PCB with a common input and output voltage application. Most of the routing is on the top layer, with the bottom layer consisting of a large ground plane. The placement of the external components satisfies the electrical considerations, and the thermal perfor-

mance has been improved by adding thermal vias and a top layer "Dog-Bone".

For certain high power applications, the PCB land may be modified to a "dog bone" shape (see Figure 8). Increasing the size of ground plane and adding thermal vias can reduce the $R_{\theta JA}$ for the application.

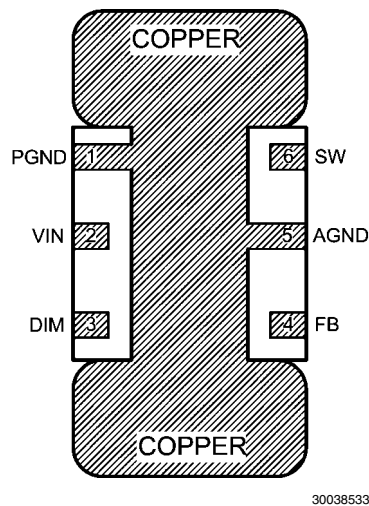

FIGURE 8. PCB Dog Bone Layout

Thermal Design

When designing for thermal performance, one must consider many variables:

Ambient Temperature: The surrounding maximum air temperature is fairly explanatory. As the temperature increases, the junction temperature will increase. This may not be linear though. As the surrounding air temperature increases, resistances of semiconductors, wires and traces increase. This will decrease the efficiency of the application, and more power will be converted into heat, and will increase the silicon junction temperatures further.

Forced Airflow: Forced air can drastically reduce the device junction temperature. Air flow reduces the hot spots within a design. Warm airflow is often much better than a lower ambient temperature with no airflow.

External Components: Choose components that are efficient, and you can reduce the mutual heating between devices.

PCB design with thermal performance in mind:

The PCB design is a very important step in the thermal design procedure. The LM3410 is available in three package options (5 pin SOT23, 8 pin eMSOP & 6 pin LLP). The options are electrically the same, but difference between the packages is size and thermal performance. The LLP and eMSOP have thermal Die Attach Pads (DAP) attached to the bottom of the packages, and are therefore capable of dissipating more heat than the SOT23 package. It is important that the customer choose the correct package for the application. A detailed thermal design procedure has been included in this data sheet. This procedure will help determine which package is correct, and common applications will be analyzed.

There is one significant thermal PCB layout design consideration that contradicts a proper electrical PCB layout design

consideration. This contradiction is the placement of external components that dissipate heat. The greatest external heat contributor is the external Schottky diode. It would be nice if you were able to separate by distance the LM3410 from the Schottky diode, and thereby reducing the mutual heating effect. This will however create electrical performance issues. It is important to keep the LM3410, the output capacitor, and Schottky diode physically close to each other (see PCB layout guidelines). The electrical design considerations outweigh the thermal considerations. Other factors that influence thermal performance are thermal vias, copper weight, and number of board layers.

Thermal Definitions

Heat energy is transferred from regions of high temperature to regions of low temperature via three basic mechanisms: radiation, conduction and convection.

Radiation: Electromagnetic transfer of heat between masses at different temperatures.

Conduction: Transfer of heat through a solid medium.

Convection: Transfer of heat through the medium of a fluid; typically air.

Conduction & Convection will be the dominant heat transfer mechanism in most applications.

$R_{\theta JA}$: Thermal impedance from silicon junction to ambient air temperature.

$R_{\theta JC}$: Thermal impedance from silicon junction to device case temperature.

$C_{\theta JC}$: Thermal Delay from silicon junction to device case temperature.

$C_{\theta CA}$: Thermal Delay from device case to ambient air temperature.

$R_{\theta JA}$ & $R_{\theta JC}$: These two symbols represent thermal impedances, and most data sheets contain associated values for these two symbols. The units of measurement are °C/Watt.

$R_{\theta JA}$ is the sum of smaller thermal impedances (see simplified thermal model Figures 9 and 10). Capacitors within the model represent delays that are present from the time that power and its associated heat is increased or decreased from steady state in one medium until the time that the heat increase or decrease reaches steady state in the another medium.

The datasheet values for these symbols are given so that one might compare the thermal performance of one package against another. To achieve a comparison between packages, all other variables must be held constant in the comparison (PCB size, copper weight, thermal vias, power dissipation, V_{IN} , V_{OUT} , load current etc). This does shed light on the package performance, but it would be a mistake to use these values to calculate the actual junction temperature in your application.

LM3410 Thermal Models

Heat is dissipated from the LM3410 and other devices. The external loss elements include the Schottky diode, inductor, and loads. All loss elements will mutually increase the heat on the PCB, and therefore increase each other's temperatures.

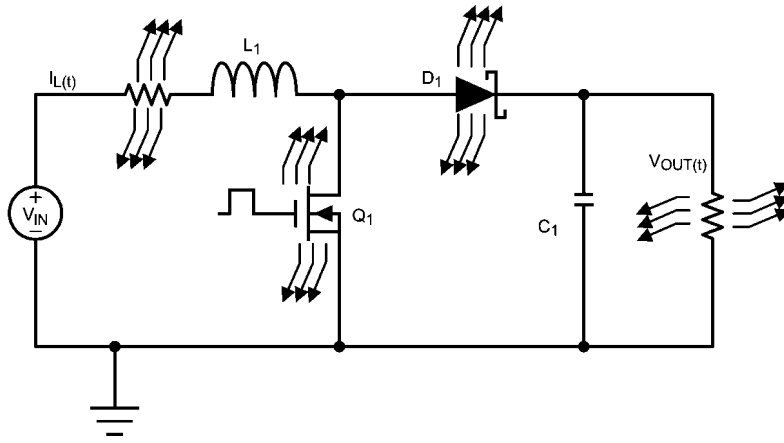

30038534

FIGURE 9. Thermal Schematic

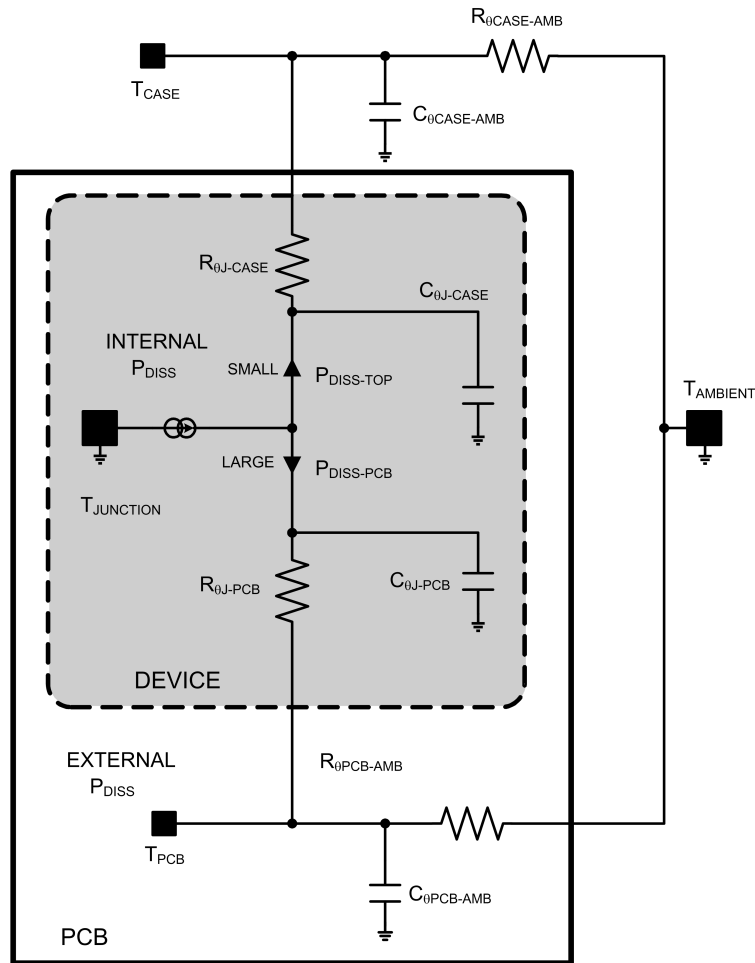

30038535

FIGURE 10. Associated Thermal Model

Calculating Efficiency, and Junction Temperature

We will talk more about calculating proper junction temperature with relative certainty in a moment. For now we need to describe how to calculate the junction temperature and clarify some common misconceptions.

$$R_{\theta JA} = \frac{T_J - T_A}{P_{\text{Dissipation}}}$$

A common error when calculating $R_{\theta JA}$ is to assume that the package is the only variable to consider.

$R_{\theta JA}$ [variables]:

- Input Voltage, Output Voltage, Output Current, $R_{\text{DS(ON)}}$
- Ambient temperature & air flow
- Internal & External components power dissipation
- Package thermal limitations
- PCB variables (copper weight, thermal via's, layers component placement)

Another common error when calculating junction temperature is to assume that the top case temperature is the proper temperature when calculating $R_{\theta JC}$. $R_{\theta JC}$ represents the thermal impedance of all six sides of a package, not just the top side. This document will refer to a thermal impedance called $R_{\Psi JC}$. $R_{\Psi JC}$ represents a thermal impedance associated with just the top case temperature. This will allow one to calculate the junction temperature with a thermal sensor connected to the top case.

The complete LM3410 Boost converter efficiency can be calculated in the following manner.

$$\eta = \frac{P_{\text{OUT}}}{P_{\text{IN}}}$$

or

$$\eta = \frac{P_{\text{OUT}}}{P_{\text{OUT}} + P_{\text{LOSS}}}$$

Power loss (P_{LOSS}) is the sum of two types of losses in the converter, switching and conduction. Conduction losses usually dominate at higher output loads, where as switching losses remain relatively fixed and dominate at lower output loads.

Losses in the LM3410 Device: $P_{\text{LOSS}} = P_{\text{COND}} + P_{\text{SW}} + P_{\text{Q}}$

Where P_{Q} = quiescent operating power loss

Conversion ratio of the Boost Converter with conduction loss elements inserted:

$$\frac{V_{\text{OUT}}}{V_{\text{IN}}} = \frac{1}{D'} \left(1 - \frac{D' \times V_D}{V_{\text{IN}}} \right) \left(\frac{1}{1 + \frac{R_{\text{DCR}} + (D \times R_{\text{DSON}})}{D'^2 R_{\text{OUT}}}} \right)$$

Where

R_{DCR} = Inductor series resistance

$$R_{\text{OUT}} = \frac{V_{\text{OUT}}}{I_{\text{LED}}}$$

One can see that if the loss elements are reduced to zero, the conversion ratio simplifies to:

$$\frac{V_{\text{OUT}}}{V_{\text{IN}}} = \frac{1}{D'}$$

And we know:

$$\frac{V_{\text{OUT}}}{V_{\text{IN}}} = \frac{\eta}{D'}$$

Therefore:

$$\eta = D' \frac{V_{\text{OUT}}}{V_{\text{IN}}} = \left(\frac{1 - \frac{D' \times V_D}{V_{\text{IN}}}}{1 + \frac{R_{\text{DCR}} + (D \times R_{\text{DSON}})}{D'^2 R_{\text{OUT}}}} \right)$$

Calculations for determining the most significant power losses are discussed below. Other losses totaling less than 2% are not discussed.

A simple efficiency calculation that takes into account the conduction losses is shown below:

$$\eta \approx \left(\frac{1 - \frac{D' \times V_D}{V_{\text{IN}}}}{1 + \frac{R_{\text{DCR}} + (D \times R_{\text{DSON}})}{D'^2 R_{\text{OUT}}}} \right)$$

The diode, NMOS switch, and inductor DCR losses are included in this calculation. Setting any loss element to zero will simplify the equation.

V_D is the forward voltage drop across the Schottky diode. It can be obtained from the manufacturer's Electrical Characteristics section of the data sheet.

The conduction losses in the diode are calculated as follows:

$$P_{\text{DIODE}} = V_D \times I_{\text{LED}}$$

Depending on the duty cycle, this can be the single most significant power loss in the circuit. Care should be taken to choose a diode that has a low forward voltage drop. Another concern with diode selection is reverse leakage current. Depending on the ambient temperature and the reverse voltage across the diode, the current being drawn from the output to the NMOS switch during time D could be significant, this may increase losses internal to the LM3410 and reduce the overall efficiency of the application. Refer to Schottky diode manufacturer's data sheets for reverse leakage specifications, and typical applications within this data sheet for diode selections.

Another significant external power loss is the conduction loss in the input inductor. The power loss within the inductor can be simplified to:

$$P_{IND} = I_{IN}^2 R_{DCR}$$

or

$$P_{IND} = \left(\frac{I_O^2 R_{DCR}}{D} \right)$$

The LM3410 conduction loss is mainly associated with the internal power switch:

$$P_{COND-NFET} = I_{SW-rms}^2 \times R_{DSON} \times D$$

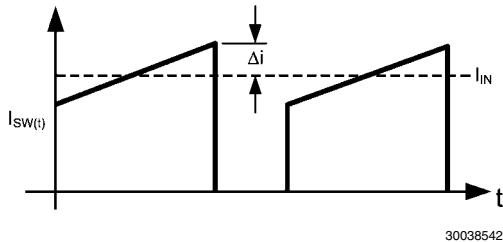

FIGURE 11. LM3410 Switch Current

$$I_{sw-rms} = I_{IND} \sqrt{D} \times \sqrt{1 + \frac{1}{3} \left(\frac{\Delta i}{I_{IND}} \right)^2} \approx I_{IND} \sqrt{D}$$

(small ripple approximation)

$$P_{COND-NFET} = I_{IND}^2 \times R_{DSON} \times D$$

or

$$P_{COND-NFET} = \left(\frac{I_{LED}}{D} \right)^2 \times R_{DSON} \times D$$

The value for R_{DSON} should be equal to the resistance at the junction temperature you wish to analyze. As an example, at 125°C and $R_{DSON} = 250 \text{ m}\Omega$ (See typical graphs for value).

Switching losses are also associated with the internal power switch. They occur during the switch on and off transition periods, where voltages and currents overlap resulting in power loss.

The simplest means to determine this loss is to empirically measuring the rise and fall times (10% to 90%) of the switch at the switch node:

$$P_{SWR} = 1/2(V_{OUT} \times I_{IN} \times f_{SW} \times t_{RISE})$$

$$P_{SWF} = 1/2(V_{OUT} \times I_{IN} \times f_{SW} \times t_{FALL})$$

$$P_{SW} = P_{SWR} + P_{SWF}$$

Typical Switch-Node Rise and Fall Times

| V_{IN} | V_{OUT} | t_{RISE} | t_{FALL} |
|----------|-----------|------------|------------|
| 3V | 5V | 6nS | 4nS |
| 5V | 12V | 6nS | 5nS |
| 3V | 12V | 8nS | 7nS |
| 5V | 18V | 10nS | 8nS |

Quiescent Power Losses

I_Q is the quiescent operating current, and is typically around 1.5 mA.

$$P_Q = I_Q \times V_{IN}$$

R_{SET} Power Loss

$$P_{RSET} = \frac{V_{FB}^2}{R_{SET}}$$

Example Efficiency Calculation:

Operating Conditions:

5 x 3.3V LEDs + 190mV_{REF} \approx 16.7V

TABLE 1. Operating Conditions

| | |
|------------|---------------|
| V_{IN} | 3.3V |
| V_{OUT} | 16.7V |
| I_{LED} | 50mA |
| V_D | 0.45V |
| f_{SW} | 1.60MHz |
| I_Q | 3mA |
| t_{RISE} | 10nS |
| t_{FALL} | 10nS |
| R_{DSON} | 225m Ω |
| L_{DCR} | 75m Ω |
| D | 0.82 |
| I_{IN} | 0.31A |

$$\Sigma P_{COND} + P_{SW} + P_{DIODE} + P_{IND} + P_Q = P_{LOSS}$$

Quiescent Power Loss:

$$P_Q = I_Q \times V_{IN} = 10 \text{ mW}$$

Switching Power Loss:

$$P_{SWR} = 1/2(V_{OUT} \times I_{IN} \times f_{SW} \times t_{RISE}) \approx 40 \text{ mW}$$

$$P_{SWF} = 1/2(V_{OUT} \times I_{IN} \times f_{SW} \times t_{FALL}) \approx 40 \text{ mW}$$

$$P_{SW} = P_{SWR} + P_{SWF} = 80 \text{ mW}$$

Internal NFET Power Loss:

$$R_{DSON} = 225 \text{ m}\Omega$$

$$P_{CONDUCTION} = I_{IN}^2 \times D \times R_{DSON} = 17 \text{ mW}$$

$$I_{IN} = 310 \text{ mA}$$

Diode Loss:

$$V_D = 0.45V$$

$$P_{DIODE} = V_D \times I_{LED} = 23 \text{ mW}$$

Inductor Power Loss:

$$R_{DCR} = 75 \text{ m}\Omega$$

$$P_{IND} = I_{IN}^2 \times R_{DCR} = 7 \text{ mW}$$

Total Power Losses are:

TABLE 2. Power Loss Tabulation

| | | | |
|--------------|---------------|-------------|-------|
| V_{IN} | 3.3V | | |
| V_{OUT} | 16.7V | | |
| I_{LED} | 50mA | P_{OUT} | 825W |
| V_D | 0.45V | P_{DIODE} | 23mW |
| f_{SW} | 1.6MHz | | |
| I_Q | 10nS | P_{SWR} | 40mW |
| t_{RISE} | 10nS | P_{SWF} | 40mW |
| I_Q | 3mA | P_Q | 10mW |
| $R_{DS(ON)}$ | 225m Ω | P_{COND} | 17mW |
| L_{DCR} | 75m Ω | P_{IND} | 7mW |
| D | 0.82 | | |
| η | 85% | P_{LOSS} | 137mW |

$$P_{INTERNAL} = P_{COND} + P_{SW} = 107 \text{ mW}$$

Calculating $R_{\theta JA}$ and $R_{\psi JC}$

$$R_{\theta JA} = \frac{T_J - T_A}{P_{Dissipation}}; R_{\psi JC} = \frac{T_J - T_{Case}}{P_{Dissipation}}$$

We now know the internal power dissipation, and we are trying to keep the junction temperature at or below 125°C. The next step is to calculate the value for $R_{\theta JA}$ and/or $R_{\psi JC}$. This is actually very simple to accomplish, and necessary if you think you may be marginal with regards to thermals or determining what package option is correct.

The LM3410 has a thermal shutdown comparator. When the silicon reaches a temperature of 165°C, the device shuts down until the temperature drops to 150°C. Knowing this, one can calculate the $R_{\theta JA}$ or the $R_{\psi JC}$ of a specific application. Because the junction to top case thermal impedance is much lower than the thermal impedance of junction to ambient air, the error in calculating $R_{\psi JC}$ is lower than for $R_{\theta JA}$. However, you will need to attach a small thermocouple onto the top case of the LM3410 to obtain the $R_{\psi JC}$ value.

Knowing the temperature of the silicon when the device shuts down allows us to know three of the four variables. Once we calculate the thermal impedance, we then can work backwards with the junction temperature set to 125°C to see what maximum ambient air temperature keeps the silicon below the 125°C temperature.

Procedure:

Place your application into a thermal chamber. You will need to dissipate enough power in the device so you can obtain a good thermal impedance value.

Raise the ambient air temperature until the device goes into thermal shutdown. Record the temperatures of the ambient air and/or the top case temperature of the LM3410. Calculate the thermal impedances.

Example from previous calculations (SOT23-5 Package):

$$P_{INTERNAL} = 107 \text{ mW}$$

$$T_A \text{ @ Shutdown} = 155^\circ\text{C}$$

$$T_C \text{ @ Shutdown} = 159^\circ\text{C}$$

$$R_{\theta JA} = \frac{T_J - T_A}{P_{Dissipation}}; R_{\psi JC} = \frac{T_J - T_{Case-Top}}{P_{Dissipation}}$$

$$R_{\theta JA} \text{ SOT23-5} = 93^\circ\text{C/W}$$

$$R_{\psi JC} \text{ SOT23-5} = 56^\circ\text{C/W}$$

Typical LLP & eMSOP typical applications will produce $R_{\theta JA}$ numbers in the range of 50°C/W to 65°C/W, and $R_{\psi JC}$ will vary between 18°C/W and 28°C/W. These values are for PCB's with two and four layer boards with 0.5 oz copper, and four to six thermal vias to bottom side ground plane under the DAP. The thermal impedances calculated above are higher due to the small amount of power being dissipated within the device.

Note: To use these procedures it is important to dissipate an amount of power within the device that will indicate a true thermal impedance value. If one uses a very small internal dissipated value, one can see that the thermal impedance calculated is abnormally high, and subject to error. Figure 12 shows the nonlinear relationship of internal power dissipation vs. $R_{\theta JA}$.

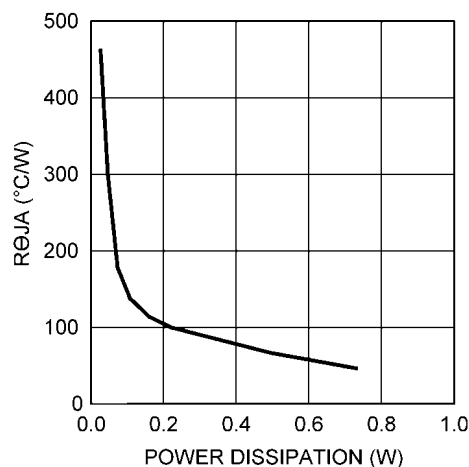

30038551

FIGURE 12. $R_{\theta JA}$ vs Internal Dissipation

For 5-pin SOT23 package typical applications, $R_{\theta JA}$ numbers will range from 80°C/W to 110°C/W, and $R_{\psi JC}$ will vary between 50°C/W and 65°C/W. These values are for PCB's with two & four layer boards with 0.5 oz copper, with two to four thermal vias from GND pin to bottom layer.

Here is a good rule of thumb for typical thermal impedances, and an ambient temperature maximum of 75°C: If your design requires that you dissipate more than 400mW internal to the LM3410, or there is 750mW of total power loss in the application, it is recommended that you use the 6 pin LLP or the 8 pin eMSOP package with the exposed DAP.

SEPIC Converter

The LM3410 can easily be converted into a SEPIC converter. A SEPIC converter has the ability to regulate an output voltage that is either larger or smaller in magnitude than the input voltage. Other converters have this ability as well (CUK and Buck-Boost), but usually create an output voltage that is opposite in polarity to the input voltage. This topology is a perfect fit for Lithium Ion battery applications where the input voltage for a single cell Li-Ion battery will vary between 2.7V & 4.5V and the output voltage is somewhere in between. Most of the

analysis of the LM3410 Boost Converter is applicable to the LM3410 SEPIC Converter.

SEPIC Design Guide:

SEPIC Conversion ratio without loss elements:

$$\frac{V_{OUT}}{V_{IN}} = \frac{D}{D'}$$

Therefore:

$$D = \frac{V_{OUT}}{V_{OUT} + V_{IN}}$$

Small ripple approximation:

In a well-designed SEPIC converter, the output voltage, and input voltage ripple, the inductor ripple I_{L1} and I_{L2} is small in comparison to the DC magnitude. Therefore it is a safe approximation to assume a DC value for these components. The main objective of the Steady State Analysis is to determine the steady state duty-cycle, voltage and current stresses on all components, and proper values for all components.

In a steady-state converter, the net volt-seconds across an inductor after one cycle will equal zero. Also, the charge into a capacitor will equal the charge out of a capacitor in one cycle.

Therefore:

$$I_{L2} = \left(\frac{D'}{D}\right) \times I_{L1}$$

and

$$I_{L1} = \left(\frac{D}{D'}\right) \times I_{LED}$$

Substituting I_{L1} into I_{L2}

$$I_{L2} = I_{LED}$$

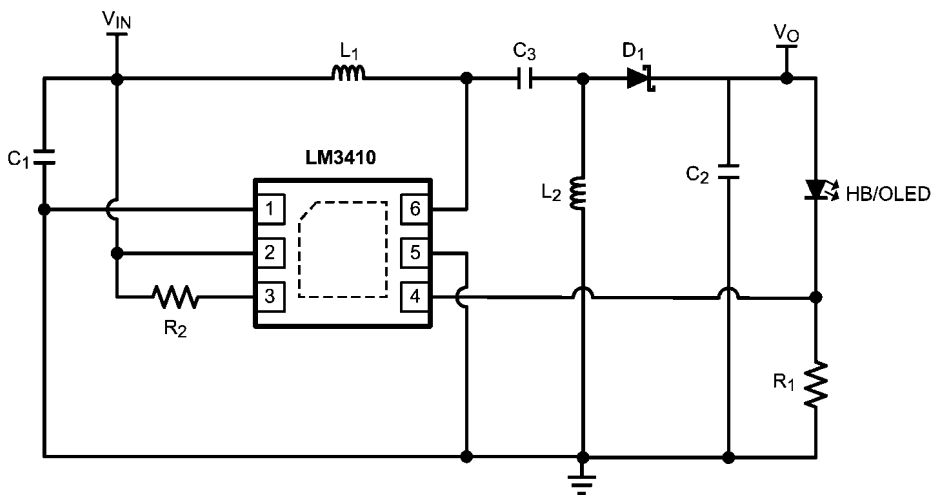
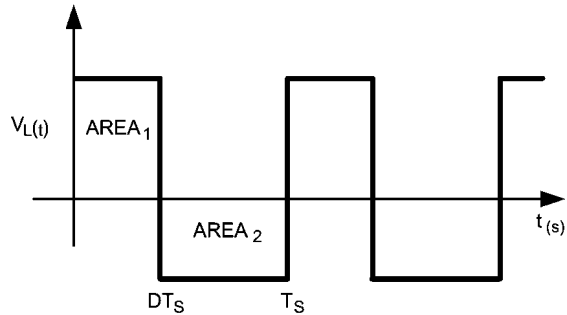

FIGURE 14. HB/OLED SEPIC CONVERTER Schematic

The average inductor current of L2 is the average output load.



30038556

FIGURE 13. Inductor Volt-Sec Balance Waveform

Applying Charge balance on C1:

$$V_{C3} = \frac{D'(V_{OUT})}{D}$$

Since there are no DC voltages across either inductor, and capacitor C3 is connected to V_{in} through L1 at one end, or to ground through L2 on the other end, we can say that

$$V_{C3} = V_{IN}$$

Therefore:

$$V_{IN} = \frac{D'(V_{OUT})}{D}$$

This verifies the original conversion ratio equation.

It is important to remember that the internal switch current is equal to I_{L1} and I_{L2} during the D interval. Design the converter so that the minimum guaranteed peak switch current limit (2.1A) is not exceeded.

30038552

Steady State Analysis with Loss Elements

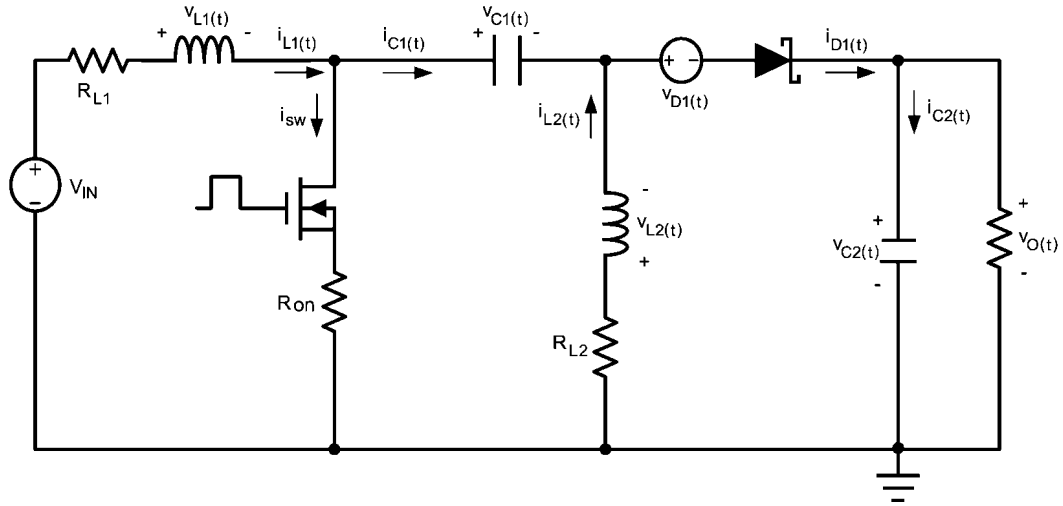

30038559

FIGURE 15. SEPIC Simplified Schematic

Using inductor volt-second balance & capacitor charge balance, the following equations are derived:

$$I_{L2} = (I_{LED})$$

and

$$I_{L1} = (I_{LED}) \times (D/D')$$

$$\frac{V_{OUT}}{V_{IN}} = \left(\frac{D}{D'} \right) \left(\frac{1}{1 + \frac{V_D}{V_{OUT}} + \frac{R_{L2}}{R}} + \left(\frac{D}{D'} \right) \left(\frac{R_{ON}}{R} \right) + \left(\frac{D^2}{D'^2} \right) \left(\frac{R_{L1}}{R} \right) \right)$$

$$R_{OUT} = \frac{V_{OUT}}{I_{LED}}$$

Therefore:

$$\eta = \left(\frac{1}{1 + \frac{V_D}{V_{OUT}} + \frac{R_{L2}}{R_{OUT}} + \left(\frac{D}{D'} \right) \left(\frac{R_{ON}}{R_{OUT}} \right) + \left(\frac{D^2}{D'^2} \right) \left(\frac{R_{L1}}{R_{OUT}} \right)} \right)$$

One can see that all variables are known except for the duty cycle (D). A quadratic equation is needed to solve for D. A less accurate method of determining the duty cycle is to assume efficiency, and calculate the duty cycle.

$$\frac{V_{OUT}}{V_{IN}} = \left(\frac{D}{1 - D} \right) \times \eta$$

$$D = \left(\frac{V_{OUT}}{(V_{IN} \times \eta) + V_{OUT}} \right)$$

TABLE 3. Efficiencies for Typical SEPIC Applications

| V _{IN} | 2.7V | V _{IN} | 3.3V | V _{IN} | 5V |
|------------------|-------|------------------|-------|------------------|-------|
| V _{OUT} | 3.1V | V _{OUT} | 3.1V | V _{OUT} | 3.1V |
| I _{IN} | 770mA | I _{IN} | 600mA | I _{IN} | 375mA |
| I _{LED} | 500mA | I _{LED} | 500mA | I _{LED} | 500mA |
| η | 75% | η | 80% | η | 83% |

SEPIC Converter PCB Layout

The layout guidelines described for the LM3410 Boost-Converter are applicable to the SEPIC OLED Converter. Figure 16 is a proper PCB layout for a SEPIC Converter.

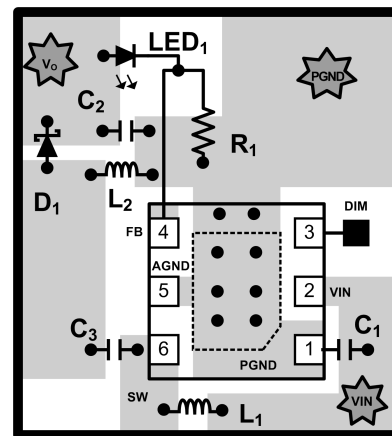

30038565

FIGURE 16. HB/OLED SEPIC PCB Layout

LM3410X SOT23-5 Design Example 1: 5 x 1206 Series LED String Application

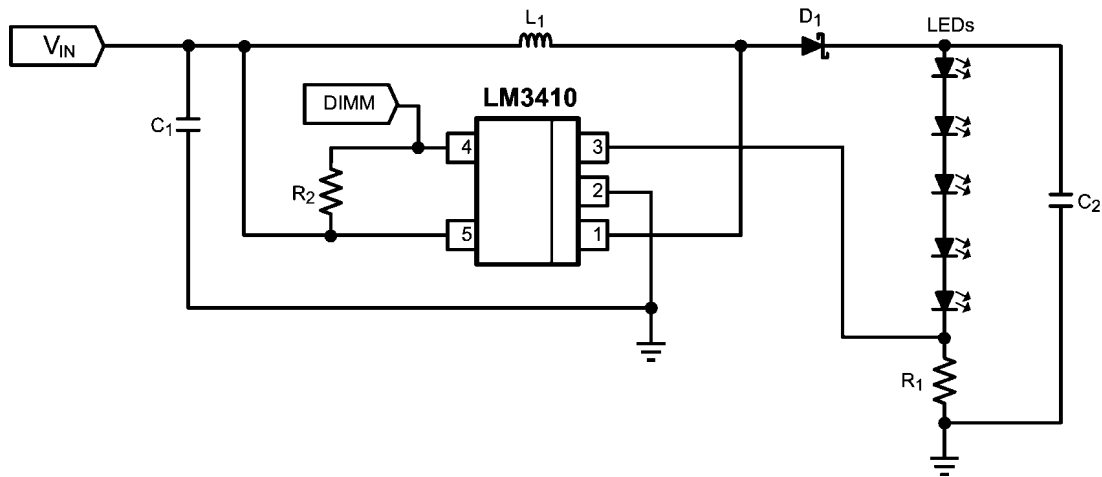

30038581

LM3410X (1.6MHz): $V_{IN} = 2.7V$ to $5.5V$, 5 x 3.3V LEDs, ($V_{OUT} \approx 16.5V$) $I_{LED} \approx 50mA$

| Part ID | Part Value | Manufacturer | Part Number |
|-----------------|--|--------------|----------------|
| U1 | 2.8A I_{SW} LED Driver | NSC | LM3410XMF |
| C1, Input Cap | 10 μ F, 6.3V, X5R | TDK | C2012X5R0J106M |
| C2 Output Cap | 2.2 μ F, 25V, X5R | TDK | C2012X5R1E225M |
| D1, Catch Diode | 0.4V _f Schottky 500mA, 30V _R | Diodes Inc | MBR0530 |
| L1 | 10 μ H 1.2A | Coilcraft | DO1608C-103 |
| R1 | 4.02 Ω , 1% | Vishay | CRCW08054R02F |
| R2 | 100k Ω , 1% | Vishay | CRCW08051003F |
| LED's | SMD-1206, 50mA, $V_f \approx 3.6V$ | Lite-On | LTW-150k |

LM3410Y SOT23-5 Design Example 2: 5 x 1206 Series LED String Application

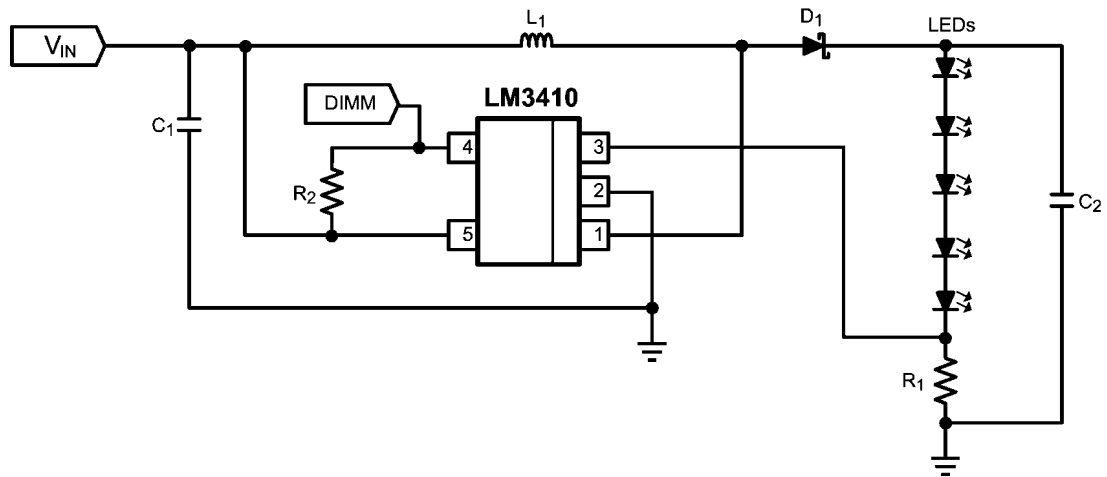

30038581

LM3410Y (550kHz): $V_{IN} = 2.7V$ to $5.5V$, 5 x 3.3V LEDs, ($V_{OUT} \approx 16.5V$) $I_{LED} \approx 50mA$

| Part ID | Part Value | Manufacturer | Part Number |
|-----------------|--|--------------|----------------|
| U1 | 2.8A I_{SW} LED Driver | NSC | LM3410YMF |
| C1, Input Cap | 10 μ F, 6.3V, X5R | TDK | C2012X5R0J106M |
| C2 Output Cap | 2.2 μ F, 25V, X5R | TDK | C2012X5R1E225M |
| D1, Catch Diode | 0.4V _f Schottky 500mA, 30V _R | Diodes Inc | MBR0530 |
| L1 | 15 μ H 1.2A | Coilcraft | DO1608C-153 |
| R1 | 4.02 Ω , 1% | Vishay | CRCW08054R02F |
| R2 | 100k Ω , 1% | Vishay | CRCW08051003F |
| LED's | SMD-1206, 50mA, V _f \approx 3.6V | Lite-On | LTW-150k |

LM3410X LLP-6 Design Example 3: 7 LEDs x 5 LED String Backlighting Application

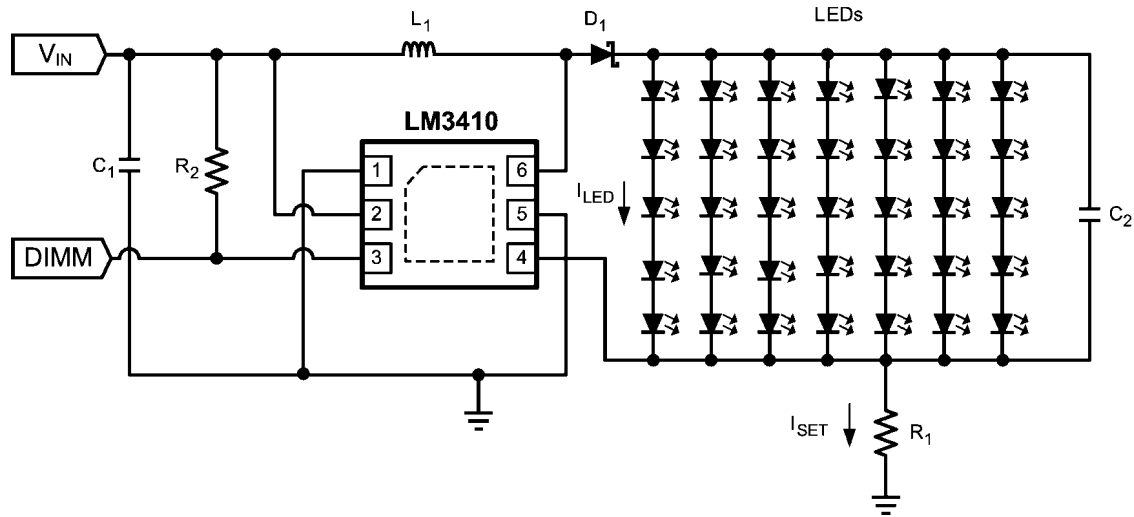

300385a2

LM3410X (1.6MHz): $V_{IN} = 2.7V$ to $5.5V$, 7 x 5 x 3.3V LEDs, ($V_{OUT} \approx 16.7V$), $I_{LED} \approx 25mA$

| Part ID | Part Value | Manufacturer | Part Number |
|-----------------|--|--------------|----------------|
| U1 | 2.8A I_{SW} LED Driver | NSC | LM3410XSD |
| C1, Input Cap | 10 μ F, 6.3V, X5R | TDK | C2012X5R0J106M |
| C2 Output Cap | 4.7 μ F, 25V, X5R | TDK | C2012X5R1E475M |
| D1, Catch Diode | 0.4V _f Schottky 500mA, 30V _R | Diodes Inc | MBR0530 |
| L1 | 8.2 μ H, 2A | Coilcraft | MSS6132-822ML |
| R1 | 1.15 Ω , 1% | Vishay | CRCW08051R15F |
| R2 | 100k Ω , 1% | Vishay | CRCW08051003F |
| LED's | SMD-1206, 50mA, $V_f \approx 3.6V$ | Lite-On | LTW-150k |

LM3410X LLP-6 Design Example 4: 3 x HB LED String Application

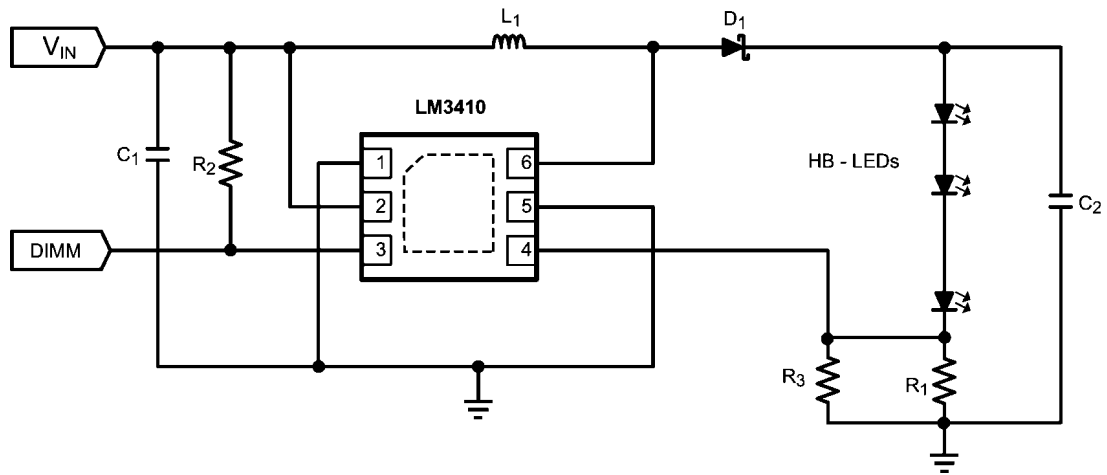

LM3410X (1.6MHz): $V_{IN} = 2.7V$ to $5.5V$, 3 x $3.4V$ LEDs, ($V_{OUT} \approx 11V$) $I_{LED} \approx 340mA$

30038567

| Part ID | Part Value | Manufacturer | Part Number |
|-----------------|--|--------------|---------------------|
| U1 | 2.8A I_{SW} LED Driver | NSC | LM3410XSD |
| C1, Input Cap | 10 μ F, 6.3V, X5R | TDK | C2012X5R0J106M |
| C2 Output Cap | 2.2 μ F, 25V, X5R | TDK | C2012X5R1E225M |
| D1, Catch Diode | 0.4V _f Schottky 500mA, 30V _R | Diodes Inc | MBR0530 |
| L1 | 10 μ H 1.2A | Coilcraft | DO1608C-103 |
| R1 | 1.00 Ω , 1% | Vishay | CRCW08051R00F |
| R2 | 100k Ω , 1% | Vishay | CRCW08051003F |
| R3 | 1.50 Ω , 1% | Vishay | CRCW08051R50F |
| HB - LED's | 340mA, $V_f \approx 3.6V$ | CREE | XREWHT-L1-0000-0901 |

LM3410Y SOT23-5 Design Example 5: 5 x 1206 Series LED String Application with OVP

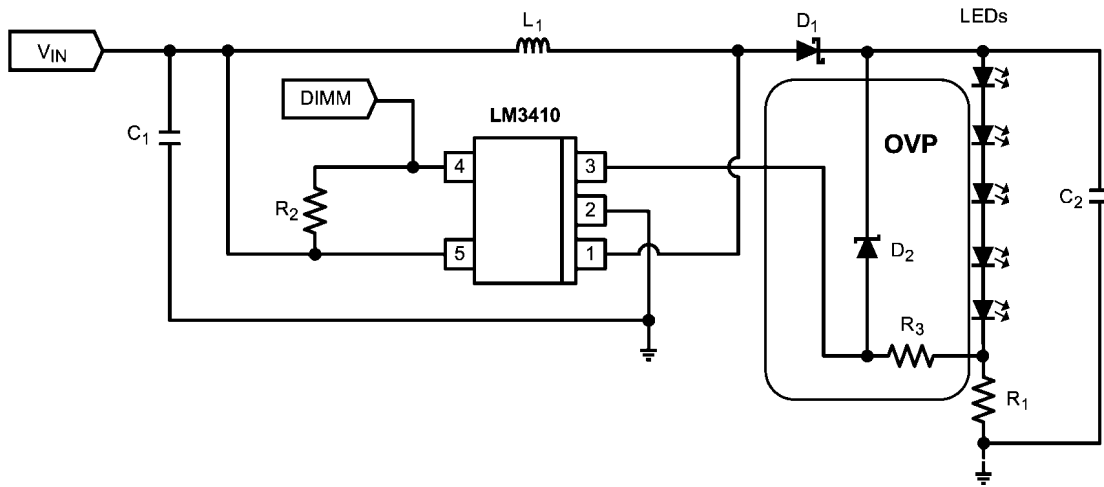

30038568

LM3410Y (525kHz): $V_{IN} = 2.7V$ to $5.5V$, 5 x 3.3V LEDs, ($V_{OUT} \approx 16.5V$) $I_{LED} \approx 50mA$

| Part ID | Part Value | Manufacturer | Part Number |
|-----------------|------------------------------------|--------------|------------------|
| U1 | 2.8A I_{SW} LED Driver | NSC | LM3410YMF |
| C1 Input Cap | 10 μ F, 6.3V, X5R | TDK | C2012X5R0J106M |
| C2 Output Cap | 2.2 μ F, 25V, X5R | TDK | C2012X5R1E225M |
| D1, Catch Diode | 0.4V _f Schottky 500mA, | Diodes Inc | MBR0530 |
| D2 | 18V Zener diode | Diodes Inc | 1N4746A |
| L1 | 15 μ H, 0.70A | TDK | VLS4012T-150MR65 |
| R1 | 4.02 Ω , 1% | Vishay | CRCW08054R02F |
| R2 | 100k Ω , 1% | Vishay | CRCW08051003F |
| R3 | 100k Ω , 1% | Vishay | CRCW06031000F |
| LED's | SMD-1206, 50mA, $V_f \approx 3.6V$ | Lite-On | LTW-150k |

LM3410X SEPIC LLP-6 Design Example 6: HB/OLED Illumination Application

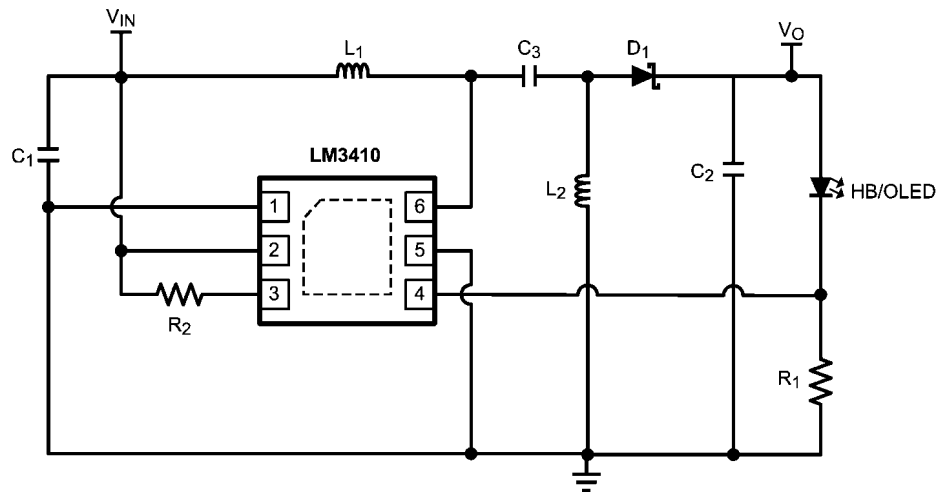

30038552

LM3410X (1.6MHz): $V_{IN} = 2.7V$ to $5.5V$, ($V_{OUT} \approx 3.8V$) $I_{LED} \approx 300mA$

| Part ID | Part Value | Manufacturer | Part Number |
|-----------------|---|--------------|---------------------|
| U1 | 2.8A I_{SW} LED Driver | NSC | LM3410XSD |
| C1 Input Cap | 10 μ F, 6.3V, X5R | TDK | C2012X5R0J106K |
| C2 Output Cap | 10 μ F, 6.3V, X5R | TDK | C2012X5R0J106K |
| C3 Cap | 2.2 μ F, 25V, X5R | TDK | C2012X5R1E225M |
| D1, Catch Diode | 0.4V _f , Schottky 1A, 20V _R | Diodes Inc | DFLS120L |
| L1 & L2 | 4.7 μ H 3A | Coilcraft | MSS6132-472 |
| R1 | 665 m Ω , 1% | Vishay | CRCW0805R665F |
| R2 | 100k Ω , 1% | Vishay | CRCW08051003F |
| HB - LED's | 350mA, V _f \approx 3.6V | CREE | XREWHT-L1-0000-0901 |

LM3410X LLP-6 Design Example 7: Boost Flash Application

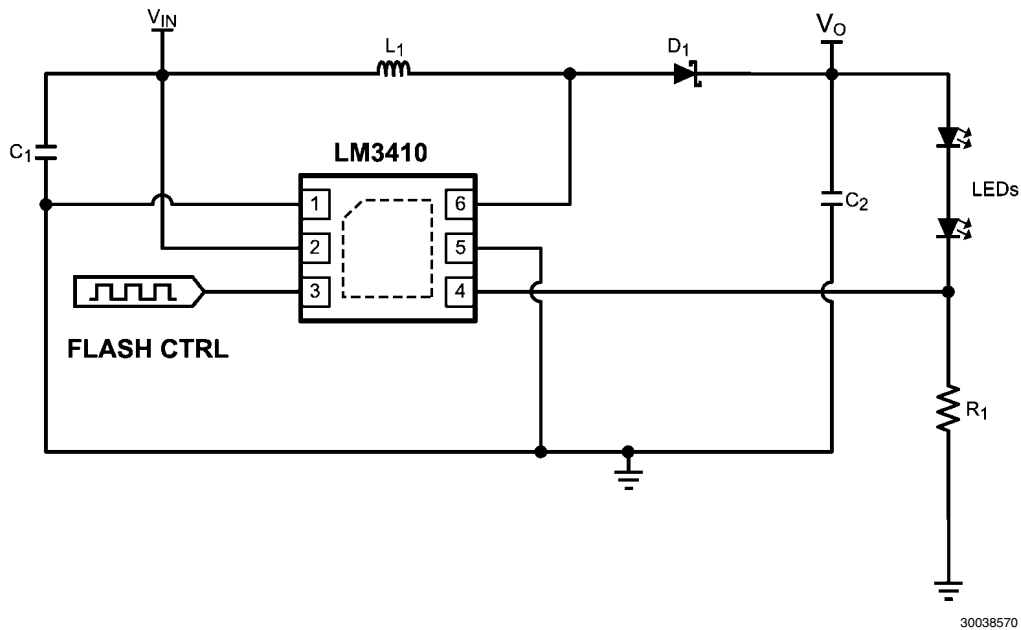

LM3410X (1.6MHz): $V_{IN} = 2.7V$ to $5.5V$, ($V_{OUT} \approx 8V$) $I_{LED} \approx 1.0A$ Pulsed

| Part ID | Part Value | Manufacturer | Part Number |
|-----------------|--|--------------|---------------------|
| U1 | 2.8A I_{SW} LED Driver | NSC | LM3410XSD |
| C1 Input Cap | 10 μ F, 6.3V, X5R | TDK | C2012X5R0J106M |
| C2 Output Cap | 10 μ F, 16V, X5R | TDK | C2012X5R1A106M |
| D1, Catch Diode | 0.4V _f Schottky 500mA, 30V _R | Diodes Inc | MBR0530 |
| L1 | 4.7 μ H, 3A | Coilcraft | MSS6132-472 |
| R1 | 200m Ω , 1% | Vishay | CRCW0805R200F |
| LED's | 500mA, $V_f \approx 3.6V$, $I_{PULSE} = 1.0A$ | CREE | XREWHT-L1-0000-0901 |

LM3410X SOT23-5 Design Example 8: 5 x 1206 Series LED String Application with $V_{IN} > 5.5V$

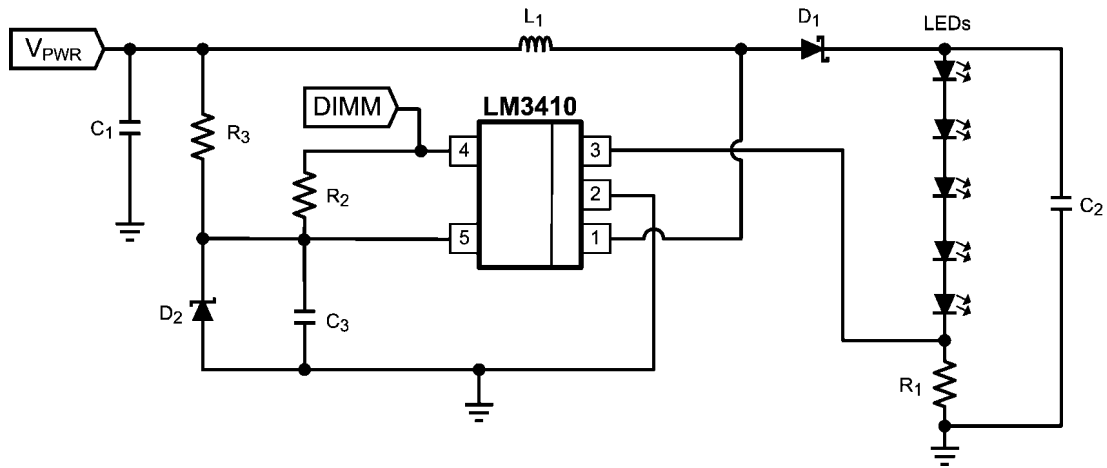

LM3410X (1.6MHz): $V_{PWR} = 9V$ to $14V$, ($V_{OUT} \approx 16.5V$) $I_{LED} \approx 50mA$

30038571

| Part ID | Part Value | Mfg | Part Number |
|------------------------|--|------------|----------------|
| U1 | 2.8A I_{SW} LED Driver | NSC | LM3410XMF |
| C1 Input V_{PWR} Cap | 10 μ F, 6.3V, X5R | TDK | C2012X5R0J106M |
| C2 Output Cap | 2.2 μ F, 25V, X5R | TDK | C2012X5R1E225M |
| C2 Input V_{IN} Cap | 0.1 μ F, 6.3V, X5R | TDK | C1005X5R1C104K |
| D1, Catch Diode | 0.43V _f , Schotky, 0.5A, 30V _R | Diodes Inc | MBR0530 |
| L1 | 10 μ H 1.2A | Coilcraft | DO1608C-103 |
| R1 | 4.02 Ω , 1% | Vishay | CRCW08054R02F |
| R2 | 100k Ω , 1% | Vishay | CRCW08051003F |
| R3 | 576 Ω , 1% | Vishay | CRCW08055760F |
| D2 | 3.3V Zener, SOT23 | Diodes Inc | BZX84C3V3 |
| LED's | SMD-1206, 50mA, $V_f \approx 3.6V$ | Lite-On | LTW-150k |

LM3410X LLP-6 Design Example 9: Camera Flash or Strobe Circuit Application

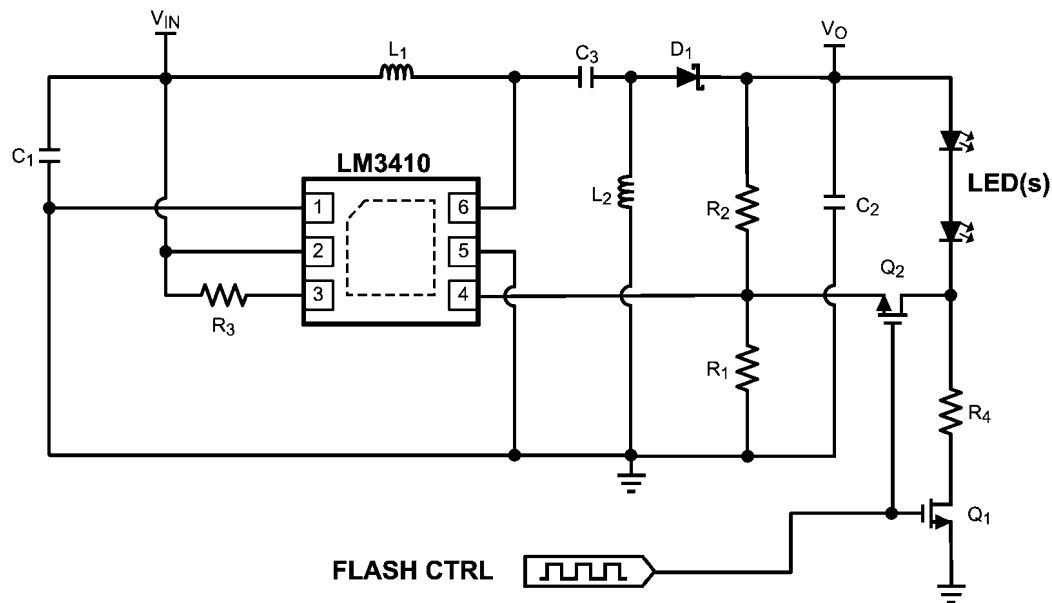

LM3410X (1.6MHz): $V_{IN} = 2.7V$ to 5.5 , ($V_{OUT} \approx 7.5V$), $I_{LED} \approx 1.5A$ Flash

30038572

| Part ID | Part Value | Mfg | Part Number |
|------------------------|--|------------|----------------------|
| U1 | 2.8A I_{SW} LED Driver | NSC | LM3410XSD |
| C1 Input V_{PWR} Cap | 10 μ F, 6.3V, X5R | TDK | C1608X5R0J106K |
| C2 Output Cap | 220 μ F, 10V, Tanatalum | KEMET | T491V2271010A2 |
| C3 Cap | 10 μ F, 16V, X5R | TDK | C3216X5R0J106K |
| D1, Catch Diode | 0.43V _f , Schotky, 1.0A, 20V _R | Diodes Inc | DFLS120L |
| L1 | 3.3 μ H 2.7A | Coilcraft | MOS6020-332 |
| R1 | 1.0k Ω , 1% | Vishay | CRCW08051001F |
| R2 | 37.4k Ω , 1% | Vishay | CRCW08053742F |
| R3 | 100k Ω , 1% | Vishay | CRCW08051003F |
| R4 | 0.15 Ω , 1% | Vishay | CRCW0805R150F |
| Q1, Q2 | 30V, $I_D = 3.9A$ | ZETEX | ZXMN3A14F |
| LED's | 500mA, $V_f \approx 3.6V$, $I_{PULSE} = 1.5A$ | CREE | XREWHT-L1-0000-00901 |

LM3410X SOT23-5 Design Example 10: 5 x 1206 Series LED String Application with V_{IN} & V_{PWR} Rail > 5.5V

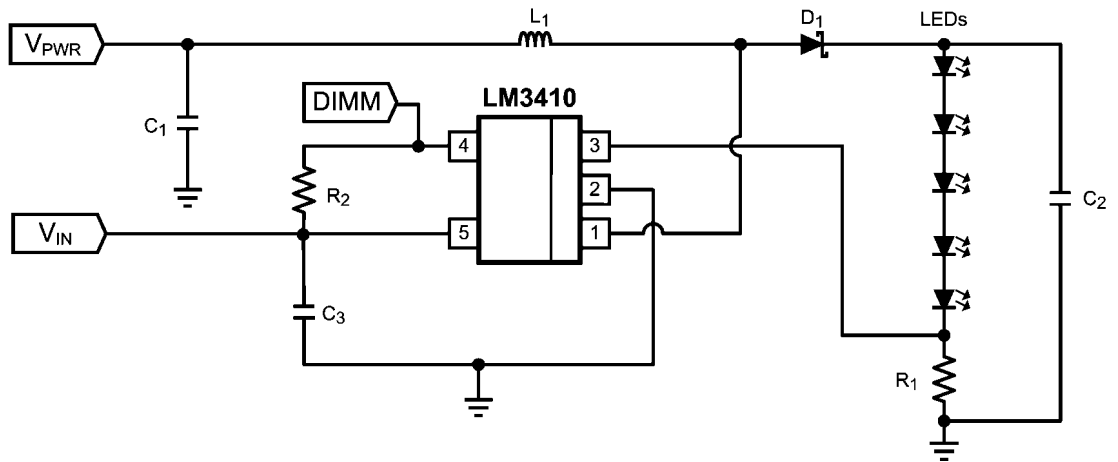

30038573

LM3410X (1.6MHz): $V_{PWR} = 9V$ to $14V$, $V_{IN} = 2.7V$ to $5.5V$, ($V_{OUT} \approx 14V$) $I_{LED} \approx 50mA$

| Part ID | Part Value | Mfg | Part Number |
|------------------------|--|------------|----------------|
| U1 | 2.8A I_{SW} LED Driver | NSC | LM3410XMF |
| C1 Input V_{PWR} Cap | 10µF, 6.3V, X5R | TDK | C2012X5R0J106M |
| C2 V_{OUT} Cap | 2.2µF, 25V, X5R | TDK | C2012X5R1E225M |
| C3 Input V_{IN} Cap | 0.1µF, 6.3V, X5R | TDK | C1005X5R1C104K |
| D1, Catch Diode | 0.43V _f , Schotky, 0.5A, 30V _R | Diodes Inc | MBR0530 |
| L1 | 10µH 1.5A | Coilcraft | DO1608C-103 |
| R1 | 4.02Ω, 1% | Vishay | CRCW08054R02F |
| R2 | 100kΩ, 1% | Vishay | CRCW08051003F |
| LED's | SMD-1206, 50mA, $V_f \approx 3.6V$ | Lite-On | LTW-150k |

LM3410X LLP-6 Design Example 11: Boot-Strap Circuit to Extended Battery Life

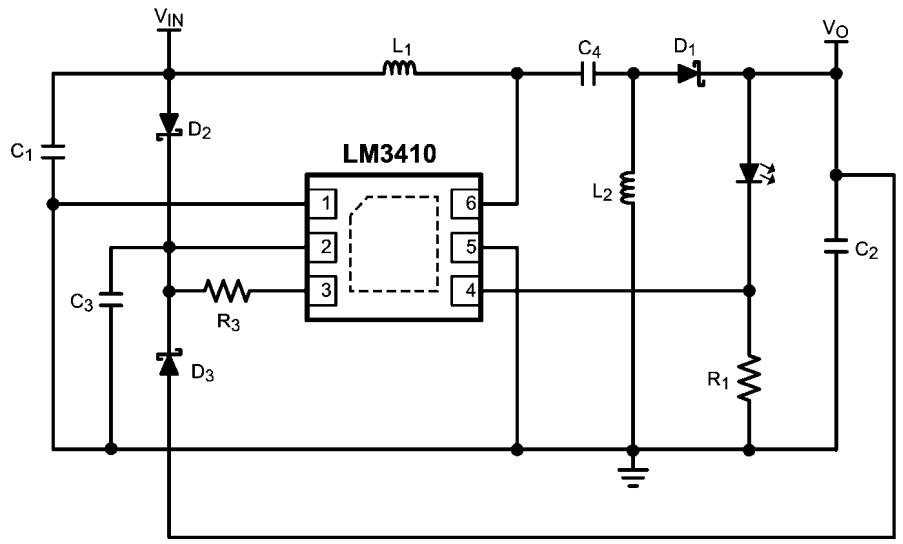

LM3410X (1.6MHz): $V_{IN} = 1.9V$ to $5.5V$, $V_{IN} > 2.3V$ (TYP) for Start Up

30038574

| Part ID | Part Value | Mfg | Part Number |
|------------------------|--|----------------------|----------------|
| U1 | 2.8A I_{SW} LED Driver | NSC | LM3410XSD |
| C1 Input V_{PWR} Cap | 10µF, 6.3V, X5R | TDK | C1608X5R0J106K |
| C2 V_{OUT} Cap | 10µF, 6.3V, X5R | TDK | C1608X5R0J106K |
| C3 Input V_{IN} Cap | 0.1µF, 6.3V, X5R | TDK | C1005X5R1C104K |
| D1, Catch Diode | 0.43V _f , Schotky, 1.0A, 20V _R | Diodes Inc | DFLS120L |
| D2, D3 | Dual Small Signal Schotky | Diodes Inc | BAT54CT |
| L1, L2 | 3.3µH 3A | Coilcraft | MOS6020-332 |
| R1 | 665 mΩ, 1% | Vishay | CRCW0805R665F |
| R3 | 100kΩ, 1% | Vishay | CRCW08051003F |
| HB/OLED | 3.4V _f , 350mA | TT Electronics/Optek | OVSPWBCR44 |

Physical Dimensions inches (millimeters) unless otherwise noted

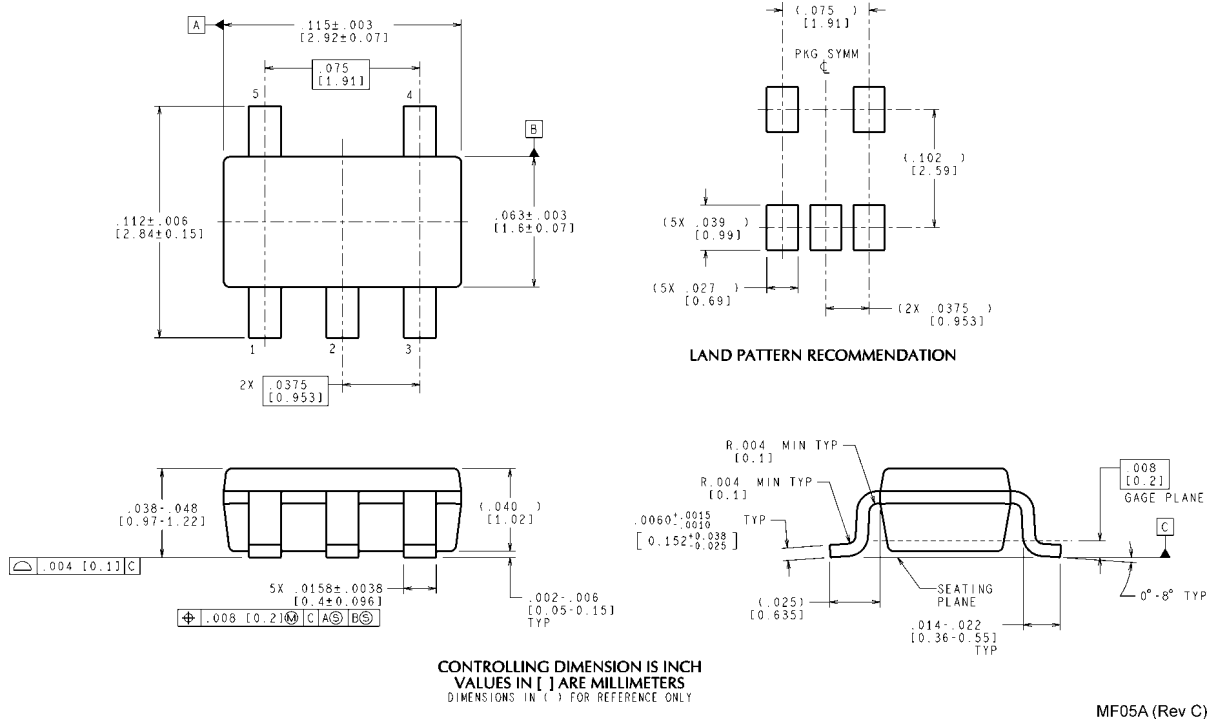
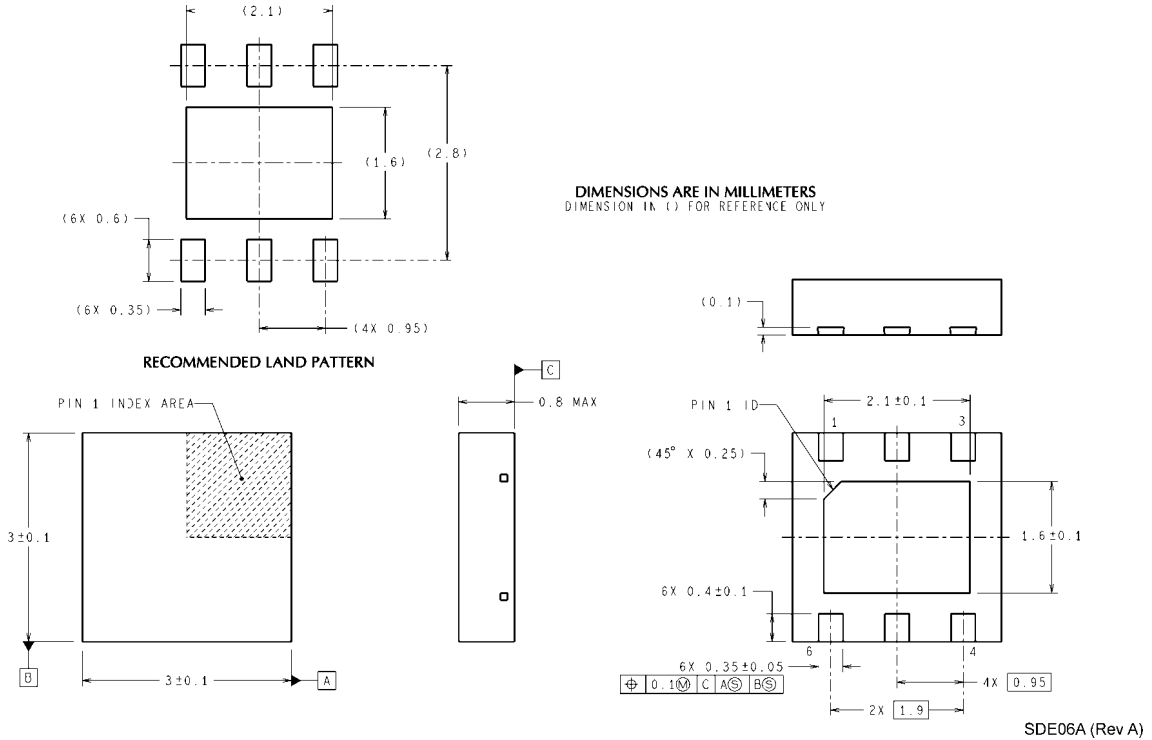

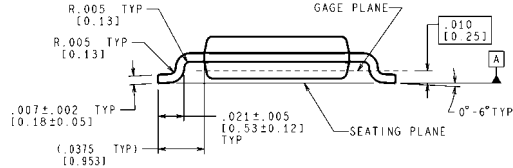
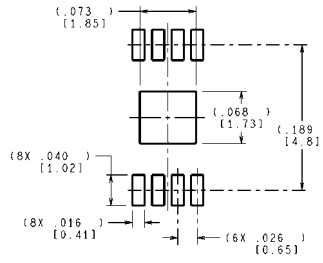
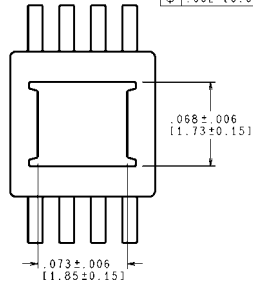
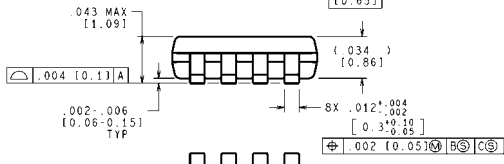
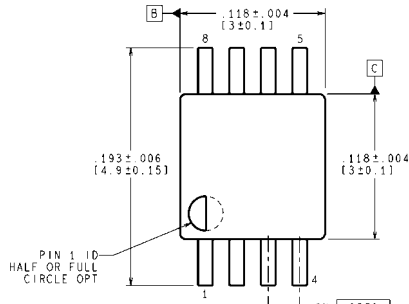

CONTROLLING DIMENSION IS INCH
VALUES IN [] ARE MILLIMETERS

**8-Lead eMSOP Package
NS Package Number MUY08A**

MUY08A (Rev A)

Notes

For more National Semiconductor product information and proven design tools, visit the following Web sites at:

| Products | | Design Support | |
|--------------------------------|--|-------------------------|--|
| Amplifiers | www.national.com/amplifiers | WEBENCH | www.national.com/webench |
| Audio | www.national.com/audio | Analog University | www.national.com/AU |
| Clock Conditioners | www.national.com/timing | App Notes | www.national.com/appnotes |
| Data Converters | www.national.com/adc | Distributors | www.national.com/contacts |
| Displays | www.national.com/displays | Green Compliance | www.national.com/quality/green |
| Ethernet | www.national.com/ethernet | Packaging | www.national.com/packaging |
| Interface | www.national.com/interface | Quality and Reliability | www.national.com/quality |
| LVDS | www.national.com/lvds | Reference Designs | www.national.com/refdesigns |
| Power Management | www.national.com/power | Feedback | www.national.com/feedback |
| Switching Regulators | www.national.com/switchers | | |
| LDOs | www.national.com/ldo | | |
| LED Lighting | www.national.com/led | | |
| PowerWise | www.national.com/powerwise | | |
| Serial Digital Interface (SDI) | www.national.com/sdi | | |
| Temperature Sensors | www.national.com/tempsensors | | |
| Wireless (PLL/VCO) | www.national.com/wireless | | |

THE CONTENTS OF THIS DOCUMENT ARE PROVIDED IN CONNECTION WITH NATIONAL SEMICONDUCTOR CORPORATION ("NATIONAL") PRODUCTS. NATIONAL MAKES NO REPRESENTATIONS OR WARRANTIES WITH RESPECT TO THE ACCURACY OR COMPLETENESS OF THE CONTENTS OF THIS PUBLICATION AND RESERVES THE RIGHT TO MAKE CHANGES TO SPECIFICATIONS AND PRODUCT DESCRIPTIONS AT ANY TIME WITHOUT NOTICE. NO LICENSE, WHETHER EXPRESS, IMPLIED, ARISING BY ESTOPPEL OR OTHERWISE, TO ANY INTELLECTUAL PROPERTY RIGHTS IS GRANTED BY THIS DOCUMENT.

TESTING AND OTHER QUALITY CONTROLS ARE USED TO THE EXTENT NATIONAL DEEMS NECESSARY TO SUPPORT NATIONAL'S PRODUCT WARRANTY. EXCEPT WHERE MANDATED BY GOVERNMENT REQUIREMENTS, TESTING OF ALL PARAMETERS OF EACH PRODUCT IS NOT NECESSARILY PERFORMED. NATIONAL ASSUMES NO LIABILITY FOR APPLICATIONS ASSISTANCE OR BUYER PRODUCT DESIGN. BUYERS ARE RESPONSIBLE FOR THEIR PRODUCTS AND APPLICATIONS USING NATIONAL COMPONENTS. PRIOR TO USING OR DISTRIBUTING ANY PRODUCTS THAT INCLUDE NATIONAL COMPONENTS, BUYERS SHOULD PROVIDE ADEQUATE DESIGN, TESTING AND OPERATING SAFEGUARDS.

EXCEPT AS PROVIDED IN NATIONAL'S TERMS AND CONDITIONS OF SALE FOR SUCH PRODUCTS, NATIONAL ASSUMES NO LIABILITY WHATSOEVER, AND NATIONAL DISCLAIMS ANY EXPRESS OR IMPLIED WARRANTY RELATING TO THE SALE AND/OR USE OF NATIONAL PRODUCTS INCLUDING LIABILITY OR WARRANTIES RELATING TO FITNESS FOR A PARTICULAR PURPOSE, MERCHANTABILITY, OR INFRINGEMENT OF ANY PATENT, COPYRIGHT OR OTHER INTELLECTUAL PROPERTY RIGHT.

LIFE SUPPORT POLICY

NATIONAL'S PRODUCTS ARE NOT AUTHORIZED FOR USE AS CRITICAL COMPONENTS IN LIFE SUPPORT DEVICES OR SYSTEMS WITHOUT THE EXPRESS PRIOR WRITTEN APPROVAL OF THE CHIEF EXECUTIVE OFFICER AND GENERAL COUNSEL OF NATIONAL SEMICONDUCTOR CORPORATION. As used herein:

Life support devices or systems are devices which (a) are intended for surgical implant into the body, or (b) support or sustain life and whose failure to perform when properly used in accordance with instructions for use provided in the labeling can be reasonably expected to result in a significant injury to the user. A critical component is any component in a life support device or system whose failure to perform can be reasonably expected to cause the failure of the life support device or system or to affect its safety or effectiveness.

National Semiconductor and the National Semiconductor logo are registered trademarks of National Semiconductor Corporation. All other brand or product names may be trademarks or registered trademarks of their respective holders.

Copyright© 2008 National Semiconductor Corporation

For the most current product information visit us at www.national.com



**National Semiconductor
Americas Technical
Support Center**
Email:
new.feedback@nsc.com
Tel: 1-800-272-9959

**National Semiconductor Europe
Technical Support Center**
Email: europe.support@nsc.com
German Tel: +49 (0) 180 5010 771
English Tel: +44 (0) 870 850 4288

**National Semiconductor Asia
Pacific Technical Support Center**
Email: ap.support@nsc.com

**National Semiconductor Japan
Technical Support Center**
Email: jpn.feedback@nsc.com